

Godzilla Kaiju Wars VR™ Operator's Manual



GODZILLA

KAIJU WARS VR™



This Page Left
Blank
Intentionally

Godzilla Kaiju Wars VR™

Table of Contents

Safety	6
Operation	6
Transporting.....	6
Handling Components	6
Disconnect Power	6
Grounding	6
Electrical Shocks.....	6
Monitor	6
Power Selector	6
Power Cord	6
Surge Suppressor	7
Water and Other Liquid Sources.....	7
Connectors	7
Computer	7
Tempered Glass Warning.....	7
Ventilation.....	7
Hazard to Epileptics	7
Manual	7
Specifications	8
Product Specifications	9
Electrical Power	9
Temperature	9
Humidity.....	9
Dimensions.....	9
Fuse Replacement Guide	9
Power Distribution.....	9
Setup	10
Safety Notice	10
Unpack Materials	10
Required Tools	10
Cabinet Assembly.....	11

Godzilla Kaiju Wars VR™

Install Spacer Bracket and Connect Motion Platform to Monitor Cabinet.....	11
Install Upper Monitor Mounting Bracket	13
Install Hanger Bracket on Upper Monitor.....	14
Install Upper Monitor on Mounting Bracket	15
Install Topper Support Brackets.....	17
Install Topper	19
Install Upper Graphic Panels.....	20
Install Downlighting Assemblies on Motion Platform	23
Completing Platform Harness, Air, and Headset Connections	24
Install Spacer Cap Panel and Lower Leg Levelers.....	25
Card Reader Installation and Setup	27
Check Electrical Settings	28
Startup Game	28
Monitor Setup.....	29
Applicable Samsung monitors:	29
Monitor Setup Continued	30
Applicable LG monitors:.....	30
Headset Calibration Guide	31
Diagnostics and Adjustments	36
Basic Functional Test on Initial Power Up.....	37
Test Menu.....	38
Main Menu.....	38
Diagnostics	39
Set Pricing Adjustments (Cash)	40
Set Pricing Adjustments (Tokens)	41
Set Pricing Adjustments (Swipes).....	42
Game Settings	43
System Settings.....	44
Audits	45
Resets	46
Volume	47
Calibration.....	48
Utilities.....	49

Godzilla Kaiju Wars VR™

System Information..... 50

Choosing the Right Pricing Adjustments for Your Location 51

PC Hardware 52

PC Hard Drive Recovery 53

Troubleshooting 54

Electrical and Mechanical Illustrations..... 60

Godzilla Kaiju Wars VR™

Safety

Operation

Before operating game, read this manual. Failure to properly install and operate this game could result in malfunction or accident. Operate the game in accordance with the manual.

Transporting

The upper monitor assembly weighs approximately 95 lbs. and the installation requires a minimum of three people, using two 6-foot step ladders (minimum height). It is preferred that the main cabinet be moved to or very near its desired operational location before beginning any of the set-up tasks. It is also strongly recommended that the game NOT be moved with the monitor installed in the upright position. It contains fragile glass and electronic components. Avoid rough handling.

Handling Components

Many components are extremely sensitive to handling, environmental and Electrostatic Discharge (ESD) events—especially the computer. Do not handle it roughly. Before servicing, contact your distributor and inquire about the PC warranty. Use proper ESD procedures when servicing. Protect components from harmful environmental conditions, such as extreme temperatures, excessive moisture, or other damaging effects.

Disconnect Power

Always turn the power off and unplug the unit before servicing or making adjustments unless otherwise instructed. Installing or repairing components while power is on can damage the components and void the warranty.

Grounding

Avoid electrical shock. Do not plug in AC power until you have inspected and properly grounded the unit. Only plug into a grounded, three-wire outlet. Do not use a “cheater” plug or cut off the ground pin on the line cord.

Electrical Shocks

There is no isolation transformer in the cabinet. Disconnect AC power before servicing. However, be aware that lethal voltages can remain in the electronic components even when AC power is disconnected. Use extreme caution when servicing. Verify that there is a working ground connection. If the unit sustains water damage, cease using it immediately and unplug AC power.

Monitor

The monitors contain no user serviceable parts. Do not attempt to service the monitors.

Power Selector

The game is fixed for operation at either 120VAC or 230VAC, indicated by a large orange label on the back of the cabinet. The accepted AC mains voltage cannot be modified by the operator.

Power Cord

If the power cord is damaged or lost, replace it with an identical cord as supplied by the manufacturer or an authorized service agent.

Godzilla Kaiju Wars VR™

Surge Suppressor

It is recommended that you plug your game's power cord into a surge suppressor to help protect from power surges that may damage sensitive electronic components.

Water and Other Liquid Sources

Do not install game near sprinkler or other water jet sources. Do not use water jet to clean game. Keep minimum clearance behind game and wall for proper ventilation but also prevent access of liquid from spills and sprays from entering ventilation holes.

Connectors

When servicing machine, ensure all connectors mate properly. If connectors do not slip in easily, do not force them. Connectors are often keyed and only connect one way. Check for correct orientation.

Computer

The computers contain sensitive components, including a hard drive. Do not handle it roughly. Contact your distributor before servicing its internal components. Ask about warranty information as it relates to the PC. Cycle AC power on or off with the cabinet power switch.

A dongle has been inserted into one of the USB ports. This is required for game play.

Do not remove the dongle except for troubleshooting purposes.

Tempered Glass Warning

When handling the LCD display glass cover take special care and set the glass down softly on a flat surface free of debris. The edge of the glass is sensitive to hard impact. Shattered glass from the monitor can travel long distances and cause bodily injury. Use proper procedures when handling broken materials.

Ventilation

It is critical that the game is installed in a manner that allows for proper ventilation and air flow. Game must be installed so that there is a minimum amount of clearance between the wall or another game to allow good air circulation through the game cooling fan and vents.

Hazard to Epileptics

A small portion of the population has an epileptic condition that may cause seizures. Affected persons experience seizure while watching some television pictures or playing certain video games. People who have not had seizures may still have an undetected epileptic condition. If anyone in your family has experienced epilepsy symptoms (seizures or loss of awareness), consult your physical before using video games. While children play video games, a parent should observe. Be alert to the following symptoms: dizziness, altered vision, eye or muscle twitching, involuntary movements, loss of awareness, disorientation, or convulsions. If you or your child experiences these symptoms, discontinue use immediately and consult your physician.

Manual

Keep this manual available and ready for use. If the game fails to function properly, turn off the machine and unplug the AC line cord. Contact your local distributor. You may not reproduce this document or any of its contents without written authorization from Raw Thrills, Inc.

Godzilla Kaiju Wars VR™

Specifications

For reasons such as performance, this product's specifications may change without notice. Federal patent, copyright and other intellectual property laws protect the content, devices and design of the game and its equipment.

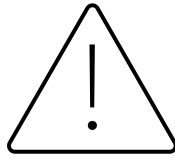

CAUTION

- This machine features moving parts and should only be serviced by a trained and experienced technician.
- Turn off all power and air supply before servicing the machine.
- Keep area around the machine clear and free of objects that present a trip hazard. Allow for plenty of room for players to safely enter and exit the machine.
- Observe ALL of the following guidelines to prevent injury, accident, or damage.
 - Maximum of two persons on the machine at any time.
 - If a player fatigues or experiences motion sickness or is unable to continue the game for any reason, stop the game motion immediately by pressing the MOTION STOP button. Allow the person to rest and exit the game with assistance if needed.
 - Remain seated for the entire duration of the game. Do not stand or exit while the game is moving. Press the MOTION STOP button before exiting the game.
 - Keep hands and legs inside the game at all times while in motion. Remain in the game until game comes to a complete stop.
 - Do not attempt to reach for objects on the floor or near the game when it is moving. Stay clear and stand at a safe distance while game is in motion.
 - Small children should always be accompanied by a parent or guardian.
- The machine is equipped with safety features which the operator and the player need to be familiar with:
 - There is a MOTION STOP button located in between of player 1 and 2. This button will stop the motion feature once pressed.
 - Bellows around the moving part of the machine prevent access between the base and the moving part. Make sure that the bellows are not damaged or showing signs of excessive wear that could lead to failure. Replace the bellows when this occurs. Use only tamper proof screw fasteners as specified.
 - The machine is designed so that there is no unintended movement in the absence of a logic signal as might be experienced during a power outage. Make sure that the machine is safe to operate before turning power back ON.
- Critical parts should be maintained and inspected regularly for safe operation. If those critical parts are damaged, broken, or installed incorrectly, replace them, or install correctly. Use only manufacturer's specified parts for continued safety and reliability. Contact your distributor to order replacement parts.

Godzilla Kaiju Wars VR™

Product Specifications

Electrical Power

MULTIPLE POWER SUPPLY ENTRIES

Warning: Before obtaining access to terminals, all supply circuits must be disconnected.

Attention: Avant d'accéder aux bornes, tous les circuits d'alimentation doivent être déconnectés.

United States, Canada

Voltage: 120VAC / 60 Hz

Operating AC Current: 20 Amps (10 Amps per entry)

International

Voltage: 230VAC / 50Hz

Operating AC Current: 10 Amps (5 Amps per entry)

Temperature

50° F to 104° F

(10° C to 40° C)

Humidity

Must not exceed 95% relative humidity

Dimensions

134”H x 62”W x 108”D (341cm H x 158cm W x 275cm D)

Approximate weight 1627lbs. (~739kg)

No Topper installed:

114”H x 62”W x 108”D (290cm H x 158cm W x 275cm D)

Recommended minimum floor space requirement:

140”H x 100”W x 120”D (356cm H x 254cm W x 305cm D)

Fuse Replacement Guide

NOTE: FOR CONTINUED PROTECTION AGAINST FIRE AND ELECTRICAL DAMAGE, USE ONLY SPECIFIED FUSE TYPE AND VALUE.

Power Distribution

Please see unit for specified fuse labeling.

Abbreviations:

5A 250V	5A, 250VAC Fast Acting 3AG Fuse	Littelfuse 0312005.MXP (or equivalent)
10A 250V	10A, 250VAC Fast Acting 3AG Fuse	Littelfuse 0312010.MXP (or equivalent)
2A 250V	2A, 250VAC Slow Acting 3AG Fuse	Littelfuse 0313002.MXP (or equivalent)

Godzilla Kaiju Wars VR™

Setup

Safety Notice

Installing this product requires three individuals able to lift heavy objects safely. Two 6-foot step ladders (minimum height) are required as part of the installation process. Make sure that you are familiar with the manual contents, game setup, and operations before you begin the installation process. Do not push or pull on the decorative items when completing the assembly to prevent damaging these parts. Be aware of your surroundings and individuals around you during the assembly process for your safety and the safety of others. Work only in an area with sufficient lighting and a clean, level surface.

Unpack Materials

1. Place the shipping crate(s) on a flat, stable surface.
2. Cut the banding straps and remove the cardboard, plastic sleeve, foam, and other packing materials.
3. Stage all sub-assemblies and components near the final assembly area.
4. Locate the keys taped to the coin door on the motion platform and to the ledge on monitor cabinet.
5. Check for shipping damage to the following:
 - Monitor(s)
 - Monitor bracket
 - Headset arm(s)
 - Headset(s)
 - Cabinet decals
6. Check the AC line cords for visible signs of damage.

Pay particular attention to the plug and line cord insulation.

Required Tools

1. (2) 6-foot step ladders (*minimum height*)
2. Power drill/driver
3. Screwdriver bit adapter and the following bits
 - a. T-27 tamper resistant Torx bit
 - b. T-25 tamper resistant Torx bit
 - c. Phillips
 - d. Flathead/Slotted
4. Ratcheting socket wrench and the following sockets
 - a. 7/16" socket
 - b. 3/8" socket
 - c. 1/4" socket
 - d. 10mm or 13mm socket



Check the Godzilla Kaiju Wars VR™ game page for the most up to date info!

rawthrills.com/games/godzilla-vr/

Godzilla Kaiju Wars VR™

Cabinet Assembly

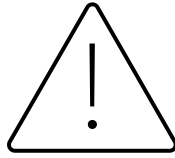

CAUTION

UNDER NO CIRCUMSTANCES SHOULD THIS GAME BE OPERATED UNLESS ALL INSTALLATION PROCEDURES HAVE BEEN COMPLETED AND ALL SAFETY FEATURES HAVE BEEN POSITIVELY TESTED AND ARE FULLY FUNCTIONAL!

*****It is recommended that the monitor cabinet be moved to or very near its desired operational location before beginning any of the assembly tasks.*****

Install Spacer Bracket and Connect Motion Platform to Monitor Cabinet

1. Locate spacer bracket sub-assembly with hardware bag (note (4) additional sets of bolts installed on bracket which will be used later to install wood spacer cap panel). Bring components near the motion platform and monitor cabinet along with 7/16" socket driver.
2. Tuck platform's cables and tubing into access holes to avoid crushing and align spacer bracket with (4) mounts on motion platform. Use 7/16" socket with 1/4"-20 x 3/4" bolts with external tooth lock washers to secure spacer bracket to motion platform. (**IMAGE 1-1**)

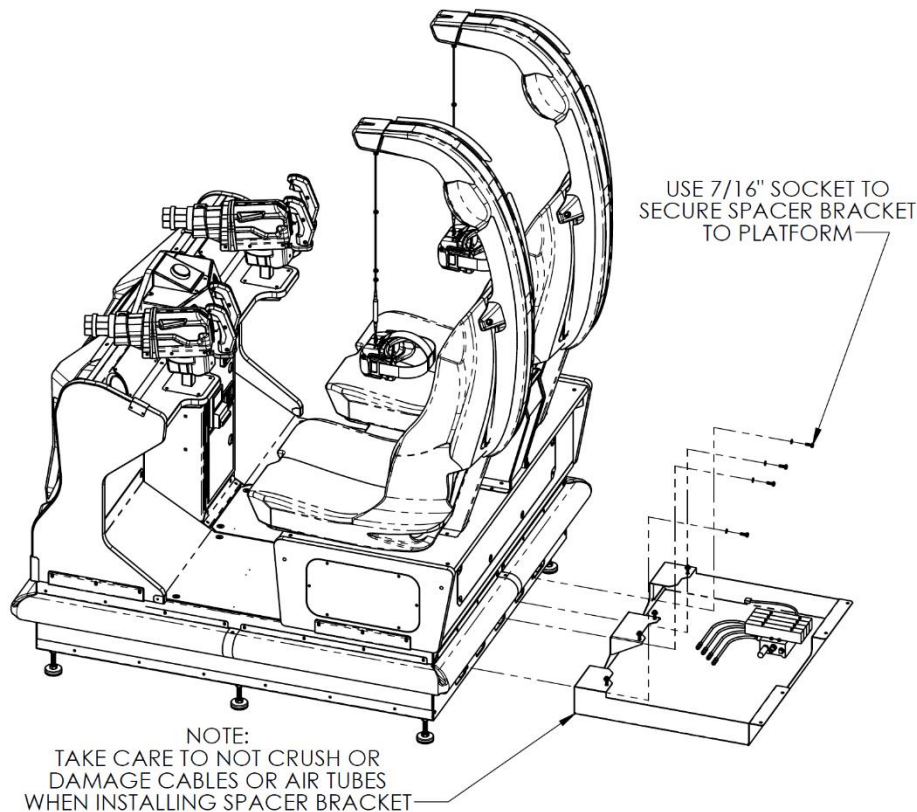

IMAGE 1-1

Godzilla Kaiju Wars VR™

3. Next, roll the motion platform in front of monitor cabinet, orient the spacer bracket to be flush and centered onto cabinet's wood ledge and aligned with (6) mounts. Use 7/16" socket with 1/4"-20 x 1" bolts with split lock washers to secure to monitor cabinet. (**IMAGE 1-2**)

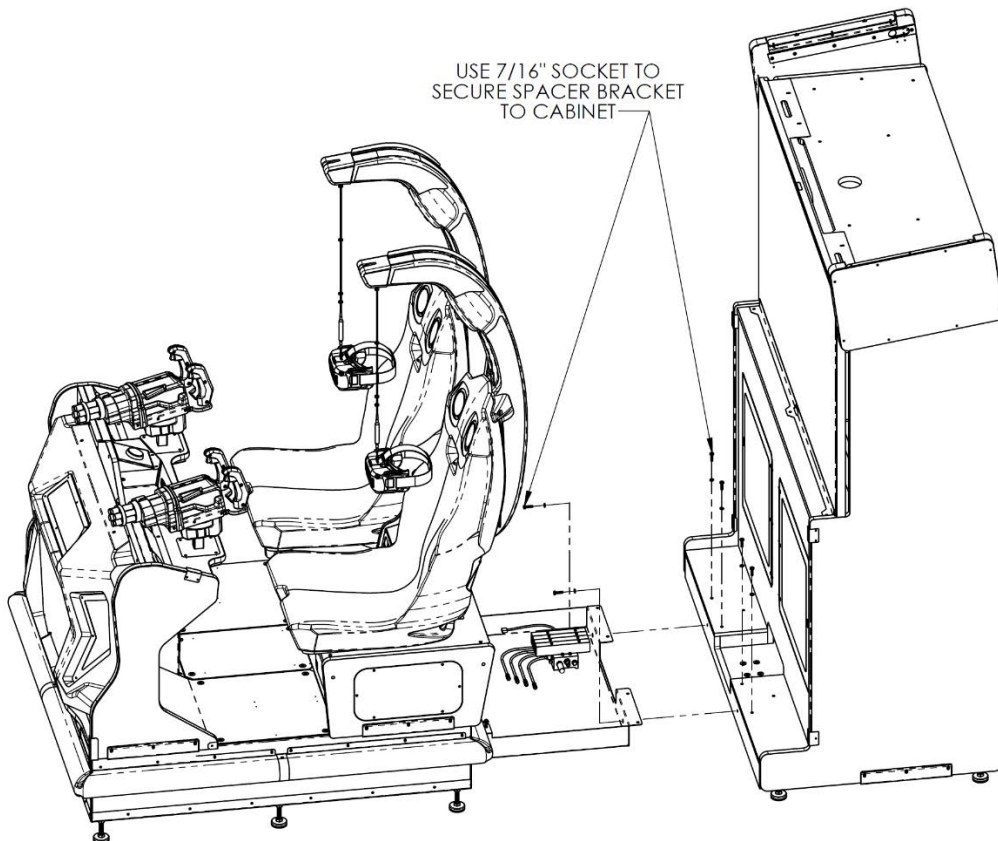

IMAGE 1-2

4. Save remaining screws, including those attached to bracket, for mounting spacer cap panel.

Godzilla Kaiju Wars VR™

Install Upper Monitor Mounting Bracket

NOTE: It is strongly recommended that the game NOT be moved once the upper monitor is installed. Access to back doors will be required in future steps. Plan for adequate AC power and future rear service access needs before completing the next steps.

1. Locate the upper monitor mounting bracket sub-assembly with hardware bag. Set up ladders next to the monitor cabinet.
2. Place upper monitor mounting bracket in position on top of the cabinet, such that (4) mounting slots in bracket align with corresponding holes on cabinet (DO NOT DROP). Use 1/4"-20 x 1-1/4" bolts with split lock washers and flat washers and hand-tighten the bracket such that it is in its rearmost position. These (4) bolts will be fully tightened using 7/16" socket once the upper monitor has been installed. Additionally, remove the wood shipping blocks from top of cabinet with 1/4" socket or flathead bit if they were not removed during unpacking (**IMAGE 2-1**)

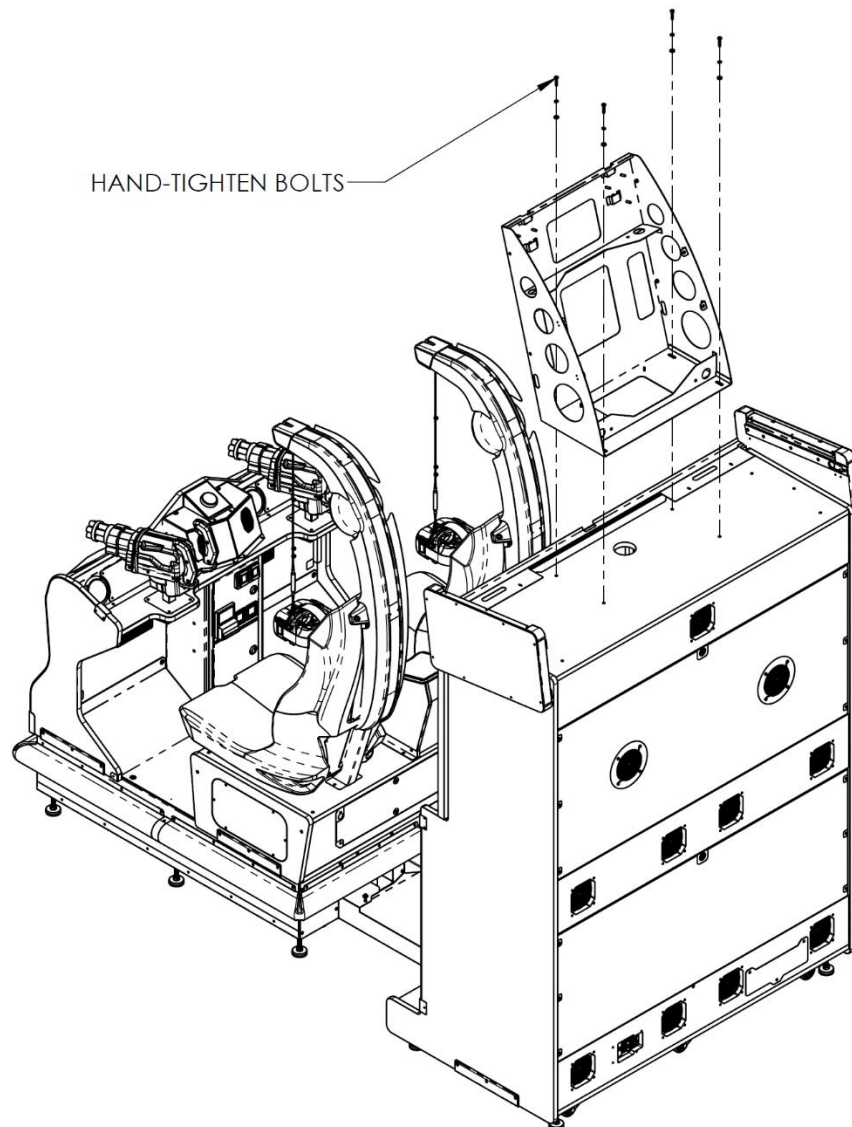

IMAGE 2-1

Godzilla Kaiju Wars VR™

Install Hanger Bracket on Upper Monitor

NOTE: Monitors change throughout production. Monitor's voltage specifications should always match game voltage specifications (120V or 230V).

1. Locate universal hanger bracket with accompanying hardware bag and supplied monitor.
 - a. FOR SAMSUNG QB65C: Lay out (4) M8 x 50MM bolts and split lock washers, (4) spacers, and 13MM socket driver. Save (4) 1/4"-20 x 3/4" bolts and split lock washers for future step.
 - b. FOR LG 65UR340C: Lay out (4) M6 x 16MM bolts and split lock washers and 10MM socket driver (no spacers are used). Save (4) 1/4"-20 x 3/4" bolts and split lock washers for future step.
2. After carefully unpacking monitor, place hanger bracket over top edge of monitor centered on VESA mounts, while monitor is preferably held upright securely. Use appropriately sized socket and supplied hardware (bolts & washers, and spacers where applicable) to secure the hanger bracket to monitor's VESA mounts (DO NOT OVERTIGHTEN). (**IMAGE 3-1 & 3-2 & 3-3**)

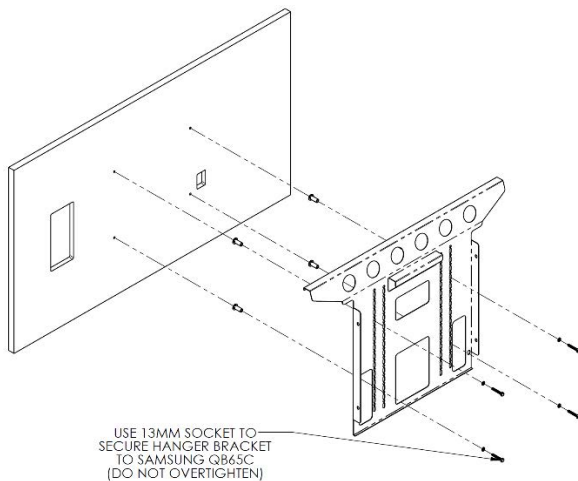

IMAGE 3-1 – QB65C

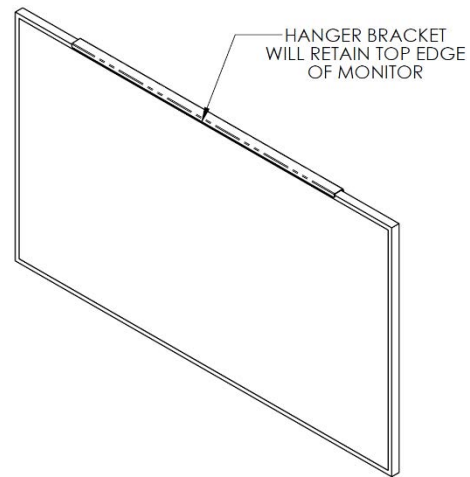

IMAGE 3-2

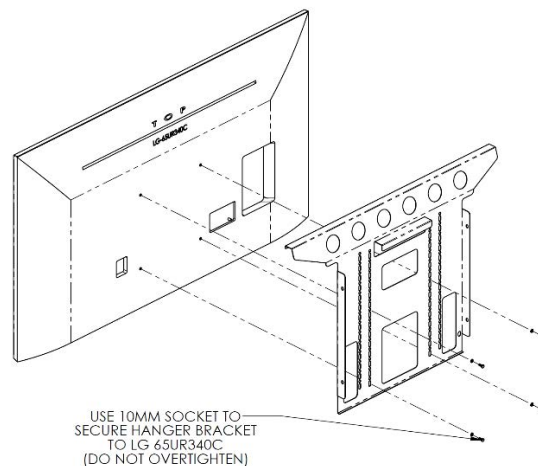

IMAGE 3-3 – 65UR340C

3. Place remaining bolts with washers and 3/8" socket atop cabinet for next steps.

Godzilla Kaiju Wars VR™

Install Upper Monitor on Mounting Bracket

1. With ladders set up next to game, (2) individuals should carry the monitor over to cabinet.
2. Climb the ladders and hang the monitor over the mounting bracket, while making sure that the lower edge of monitor is retained behind the full-width cross bracket attached to the top front edge of monitor cabinet. As necessary, shift the mounting bracket forward to close gap or back to create space. (**IMAGE 4-1**)

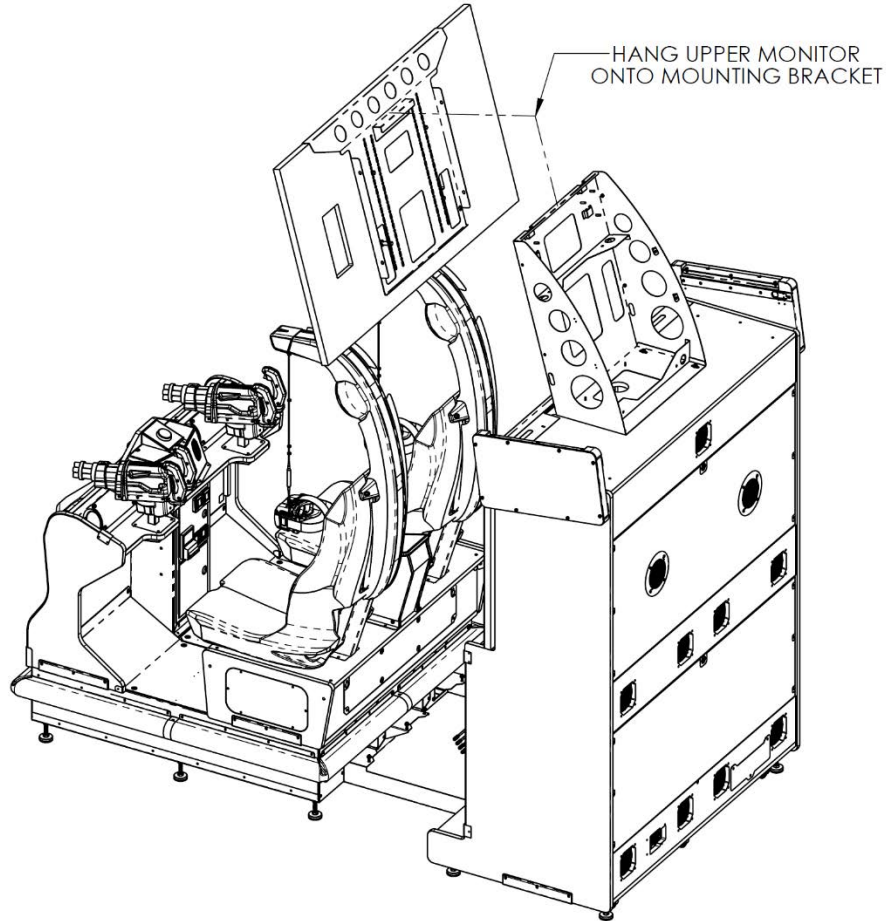

IMAGE 4-1

Godzilla Kaiju Wars VR™

3. **(IMPORTANT)** Center monitor and use 3/8" socket with 3/4" bolts and split lock washers to secure hanger to mounting bracket. **(IMAGE 4-2)**

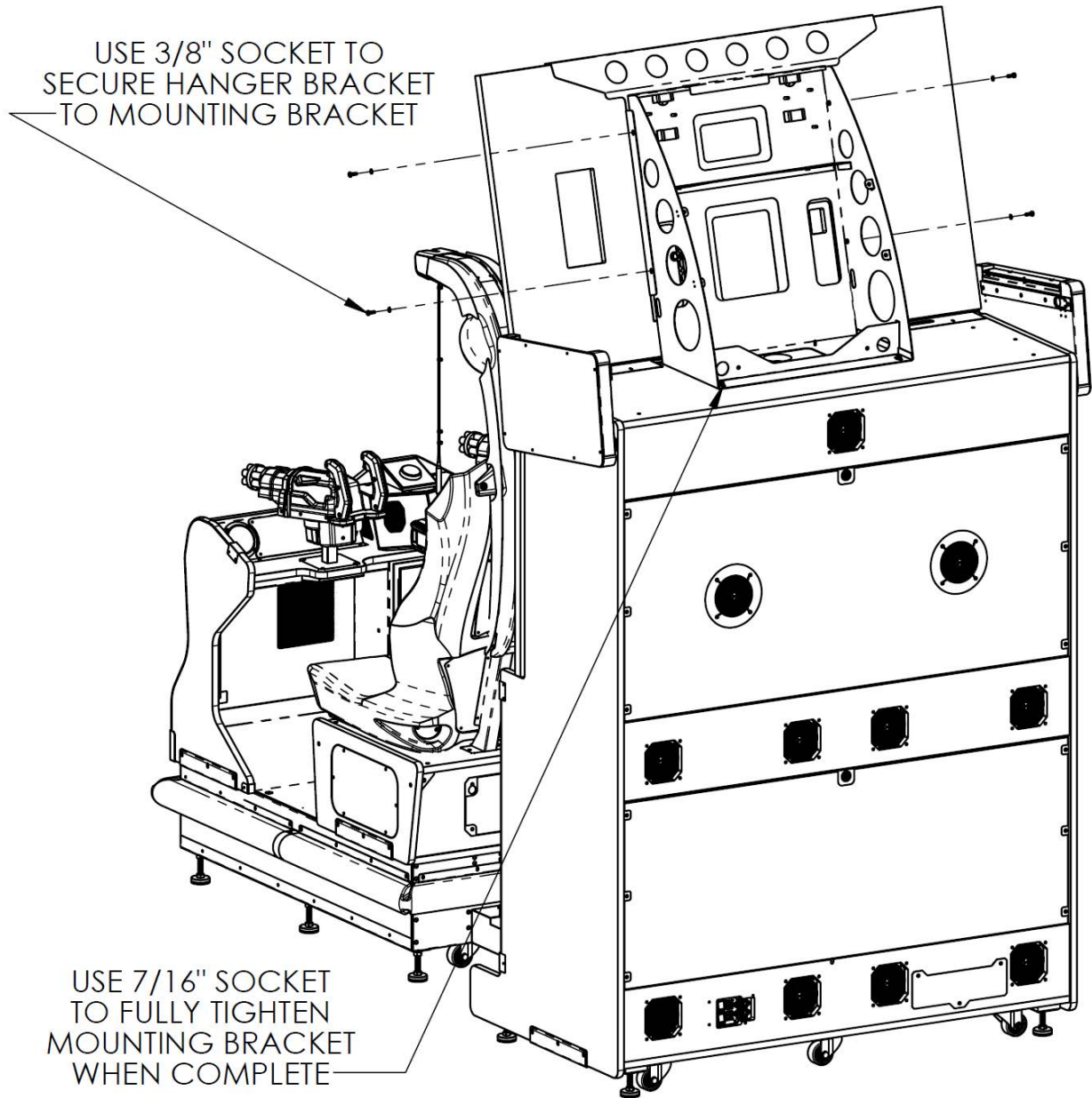

IMAGE 4-2

4. Nudge mounting brackets forward such that lower edge of monitor is flush with cross bracket, then use 7/16" socket to fully secure the (4) bolts that were hand-tightened when mounting bracket was installed on top of the cabinet.

Godzilla Kaiju Wars VR™

Install Topper Support Brackets

1. Use Phillips bit driver to remove (6) shipping screws securing upper and lower back doors of monitor cabinet. Once screws are removed, use keys to open and remove doors and safely place off to the side.
2. Use 7/16" socket to remove left and right topper support brackets from inside cabinet (note: hardware bags attached to each bracket in addition to (3) sets of screws installed along angled rear edges). (**IMAGE 5-1**)

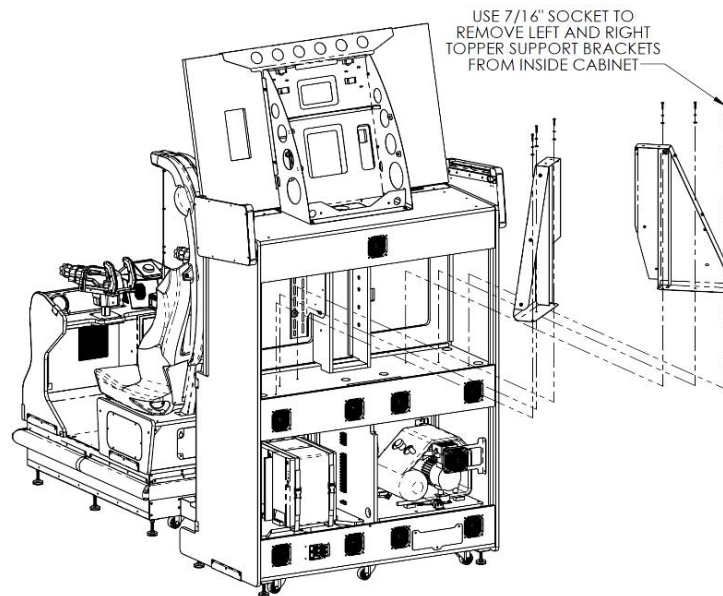

IMAGE 5-1

3. Locate cardboard box containing topper sub-assembly and unpack (take care not to damage). You should also find a loose topper support bracket with hardware bag attached. Attach topper support bracket to left and right topper support brackets with supplied (4) 1/4"-20 x 1/2" bolts with split lock washers and flat washers. These bolts should also be hand-tightened. (**IMAGE 5-2**)

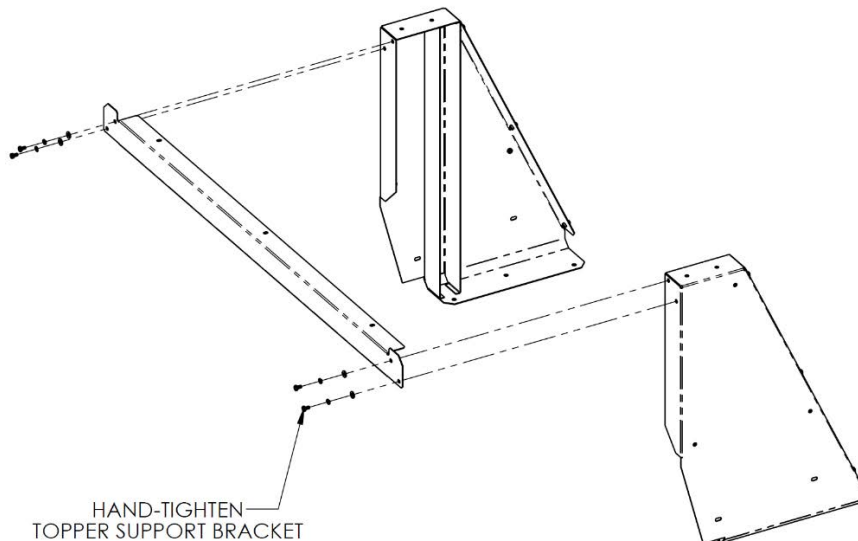

IMAGE 5-2

Godzilla Kaiju Wars VR™

- 4. With ladders set up next to game, carefully carry assembled topper support brackets up to top of cabinet and align with mounting holes. Reuse hardware and hand-tighten the bracket in place. **(IMAGE 5-3)**

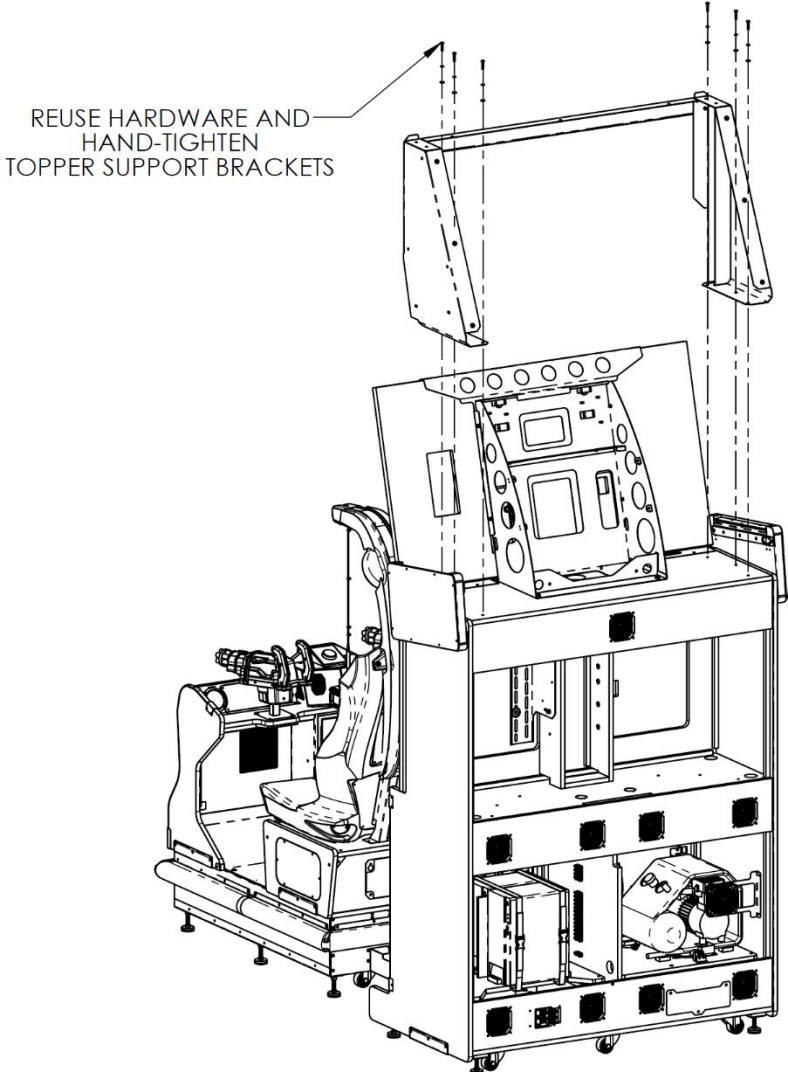

IMAGE 5-3

Godzilla Kaiju Wars VR™

Install Topper

1. Locate hardware bag attached to topper and place atop cabinet with 7/16" socket.
2. (2) individuals should carry topper up ladders and set onto support brackets, taking care not to crush cables. First, install topside outer bolts, (4) 1/4"-20 x 1-1/4" bolts with split lock washers and flat washers, into left and right support bracket mounts.
3. Next, install (3) 1/4"-20 x 1" bolts with split lock washers and flat washers along front underside of topper thru topper support bracket. Use 7/16" socket to fully tighten all topper and topper support mounts (17 total). (**IMAGE 6-1**)

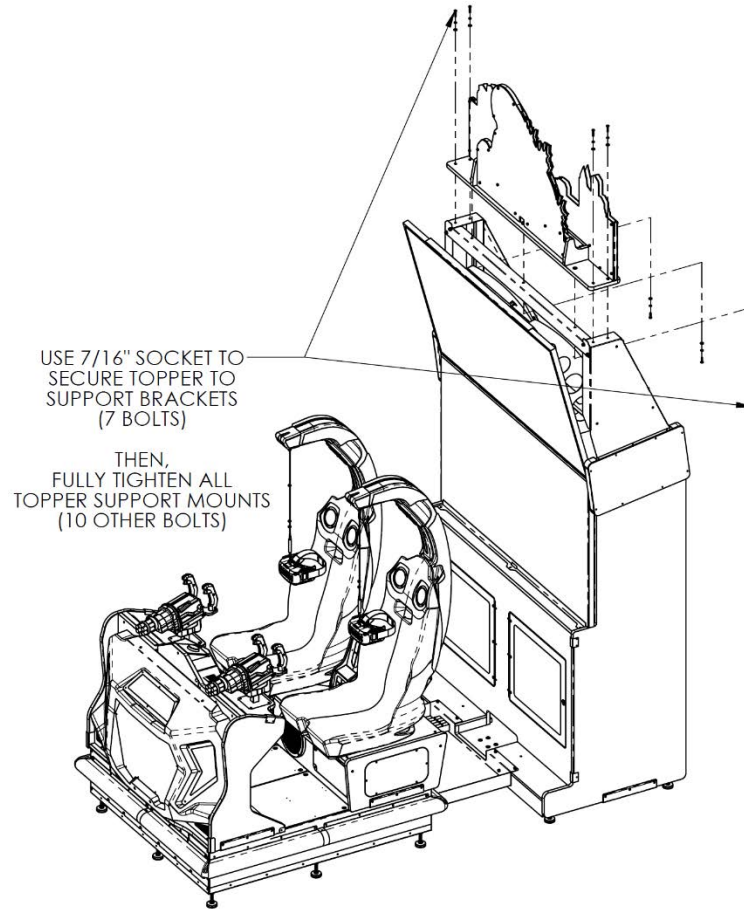

IMAGE 6-1

4. Retrieve loose 6-pin connector from topper cable through central access hole on underside of topper, route through cabinet's access hole, and plug into mating connector just inside of cabinet
5. Locate HDMI cable for upper monitor inside cabinet and locate upper monitor's supplied line cord. Using wireway hole at the top of cabinet, install HDMI cable into "HDMI 1" port of upper monitor and install AC line cord into AC power port. This HDMI cable should plug into HDMI port of "PLAYER 2" PC and the AC line cord should be plugged into AC receptacle located on left side of cabinet when viewed from the back of the game.
6. Replace back doors when complete (save shipping screws or discard).

Godzilla Kaiju Wars VR™

Install Upper Graphic Panels

1. Locate (3) upper graphic panels (left, right, and rear). Unpack hardware bags attached to left and right topper support brackets which will be used to mount left and right upper graphic panels.
2. Place right upper graphic panel in place in between right topper support bracket and right lightbox assembly attached to cabinet side. Use T27 driver with (3) 1/4"-20 x 3/4" tamperproof bolts and flat washers to loosely secure panel to mounts on right topper support bracket. **(IMAGE 7-1)**

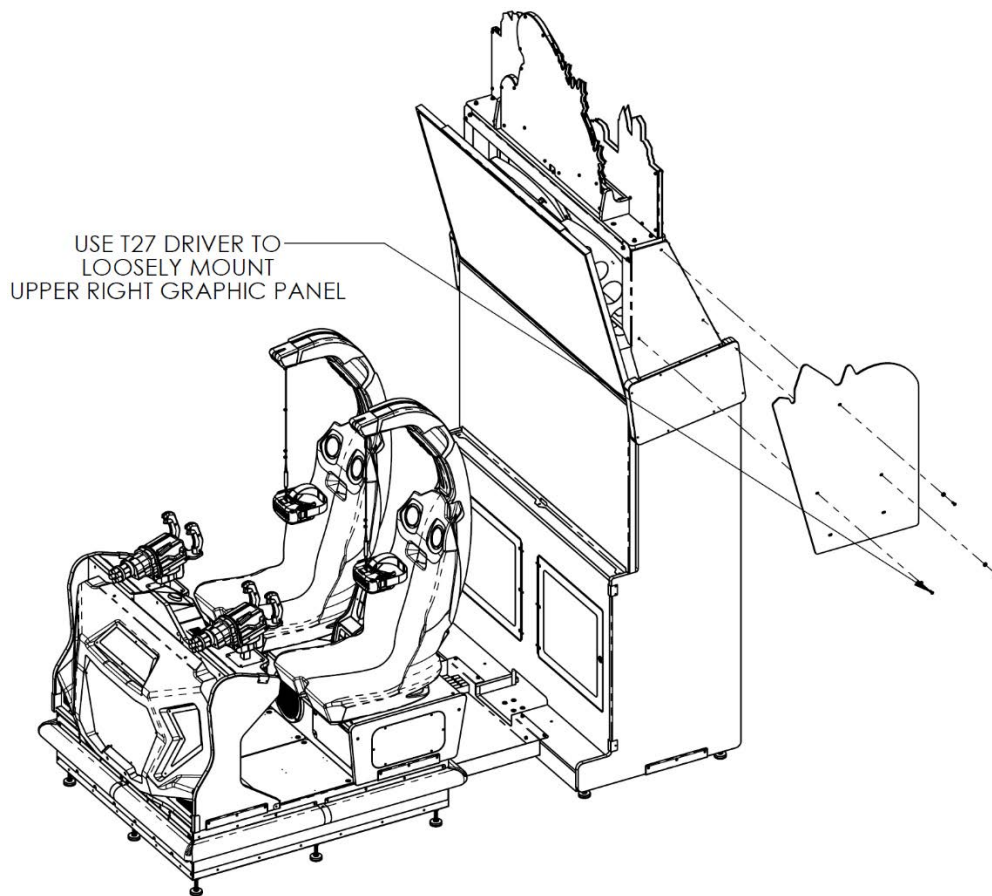

IMAGE 7-1

Godzilla Kaiju Wars VR™

- 3. Use 7/16" socket with (2) 1/4"-20 x 1" bolts with split lock washers and flat washers and install bolts from inner surface of right topper support bracket, through upper right graphic panel, and into mounts on right lightbox. Once all (5) bolts are installed, tighten fully and repeat process for left side. (IMAGE 7-2)

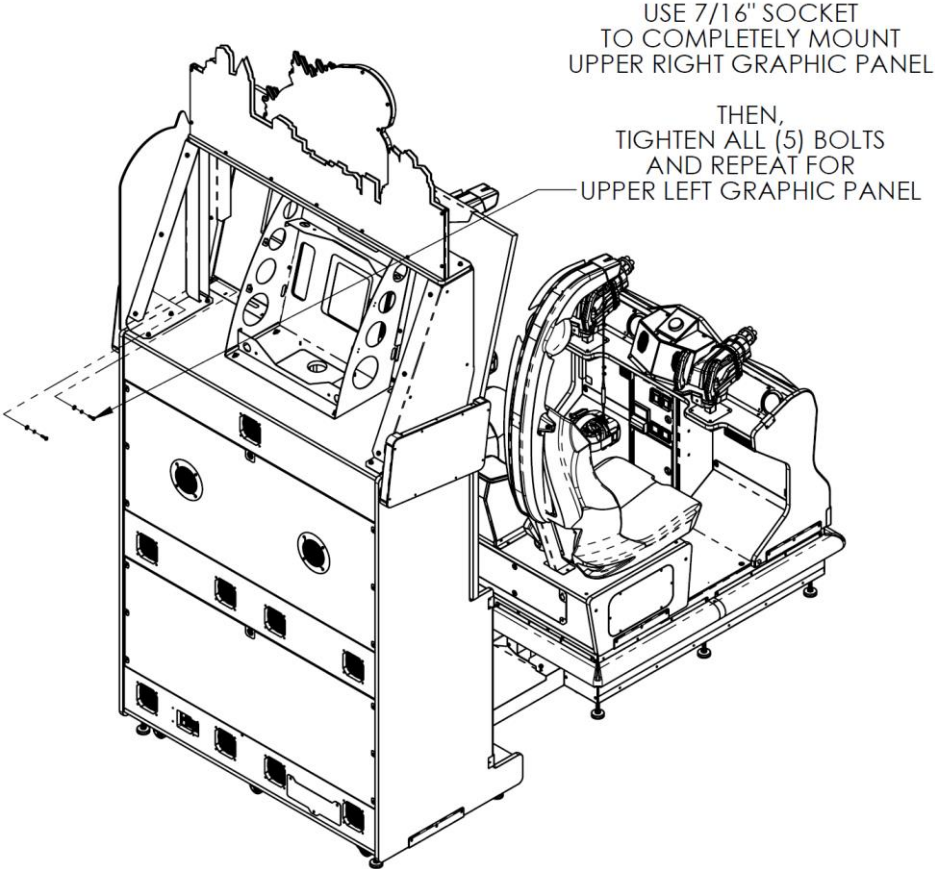

IMAGE 7-2

Godzilla Kaiju Wars VR™

- 4. Use T27 driver to remove (6) screws and washers attached to angled rear edges of left and right topper support brackets. Place upper rear graphic panel onto angled rear edge and replace screws and washers. (**IMAGE 7-3**)

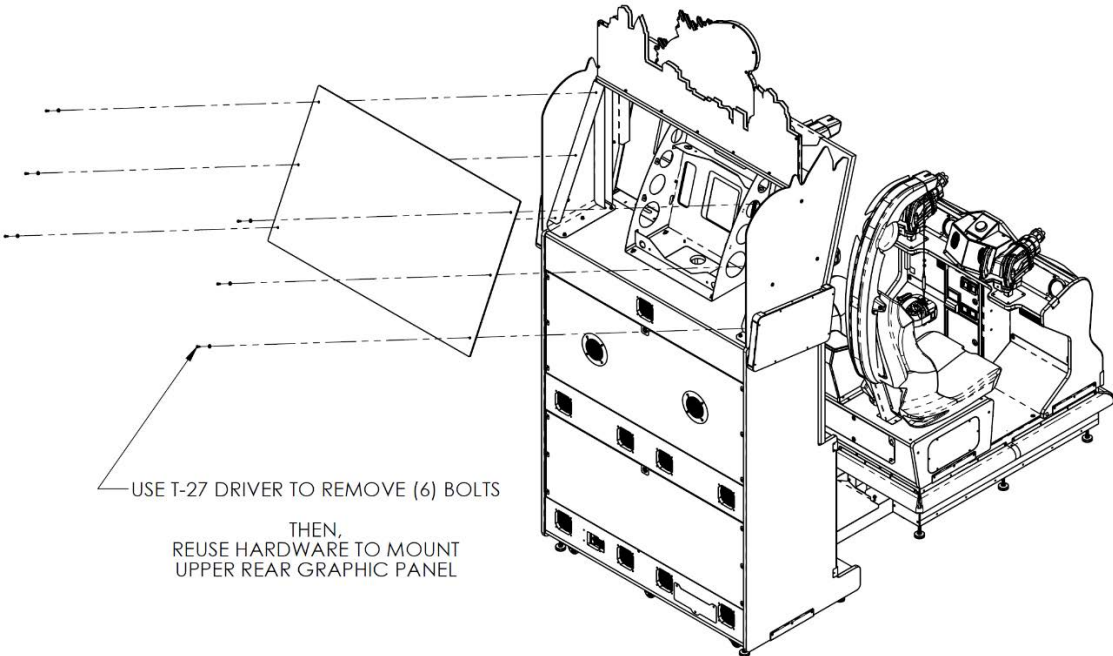

IMAGE 7-3

Godzilla Kaiju Wars VR™

Install Downlighting Assemblies on Motion Platform

1. Locate (6) downlighting assemblies and accompany hardware bag. Note that there are (3) assemblies where wires exit on right side of the bracket and (3) where wires exit on left side.
2. Using images below for reference, place downlighting assemblies in their wiring-specific locations and connect to mating connectors near cable clamps at corners on underside of platform base. Then, taking care not to crush any wires, install assemblies on front and sides of platform base by inserting brackets tabs into cutouts on underside of platform base and rotating the assembly into place such that the (3) brackets holes align with platforms mounts. Use T-25 driver to securely mount. (**IMAGE 8-1 & 8-2**)

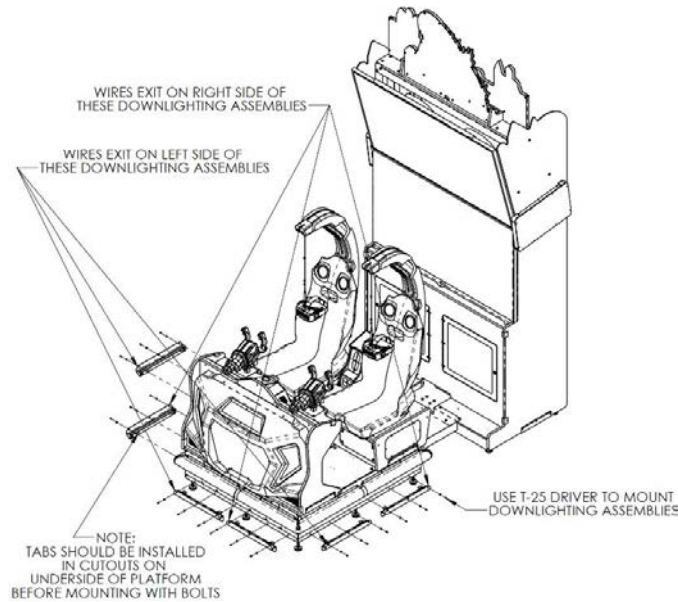

IMAGE 8-1

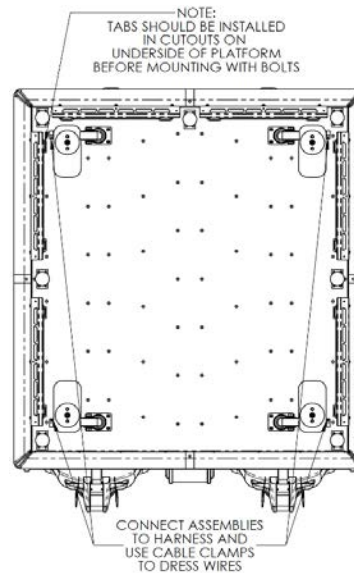

IMAGE 8-2

3. After downlighting assemblies are secure, use cable clamps to dress wires and tuck excess wire slack back into access holes.

Godzilla Kaiju Wars VR™

Completing Platform Harness, Air, and Headset Connections

1. Retrieve all harness, air tubes, and headset cables from platform access holes and place within spacer bracket.
2. Retrieve matching connections from within monitor cabinet's central access tunnel and connect the following:
 - (10) harness connections
 - connectors are keyed.
 - (5) air tube connections
 - air supply line from compressor to connect into spacer bracket's manifold.
 - match platform air tubes with cabinet air tubes (0, 1, 2, 3).
 - (3) headset connections each for P1 and P2 headsets
 - USB – Match to P1 or P2 PC in cabinet.
 - display port – Match to P1 or P2 PC in cabinet.
 - power (barrel connector).
3. **IMPORTANT** – When fully connected, a portion of the headsets' cable slack should be tucked within the platform. This placement will allow the cable's slack within platform to move up and down gently when the game is in motion and prevent the cables from being pulled due to cable tension. As a check on proper placement, the visible headset cables running through spacer bracket should not move while the game is in motion.



Godzilla Kaiju Wars VR™

Install Spacer Cap Panel and Lower Leg Levelers

1. Remove (4) sets of bolts installed on spacer bracket for spacer cap panel using T27 driver. Additionally, locate spacer cap panel and remaining loose hardware saved earlier. (**IMAGE 10-1**)

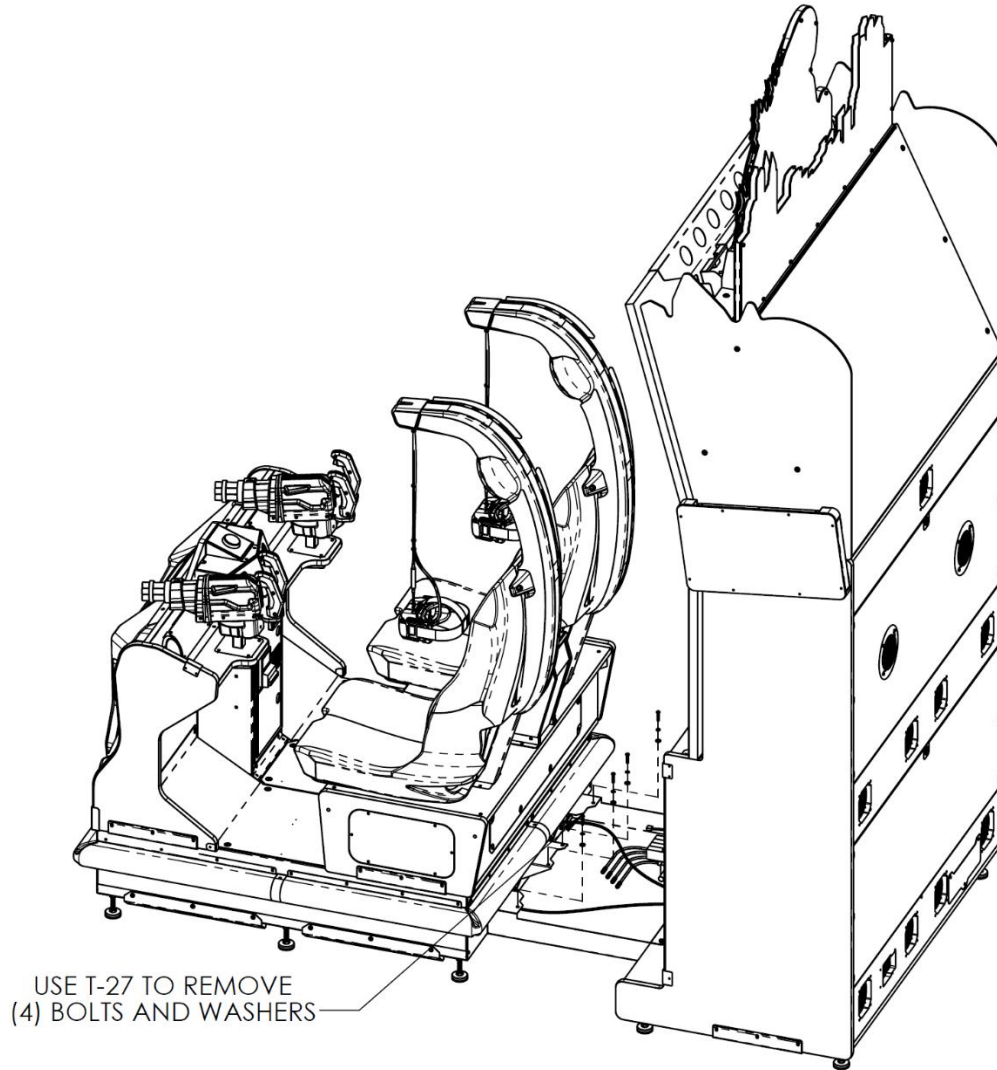

IMAGE 10-1

2. Check that all cables and air tubes are contained within spacer bracket and cabinet's central wireway channel and will not be crushed when placing spacer cap panel.

Godzilla Kaiju Wars VR™

3. Place spacer cap panel and secure to spacer bracket and cabinet with T-27 driver, using (4) 1-1/4" bolts and split lock washers and flat washers on platform side and (2) 2-1/2" bolts and split lock washers and flat washers on cabinet side. (**IMAGE 10-2 & 10-3**)

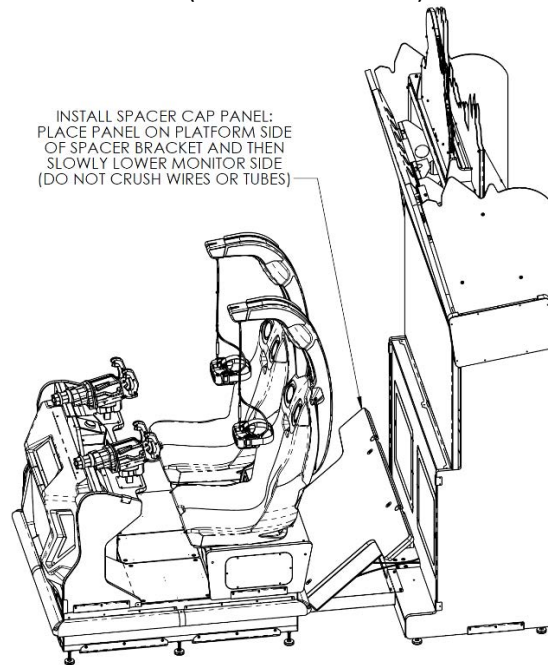

IMAGE 10-2

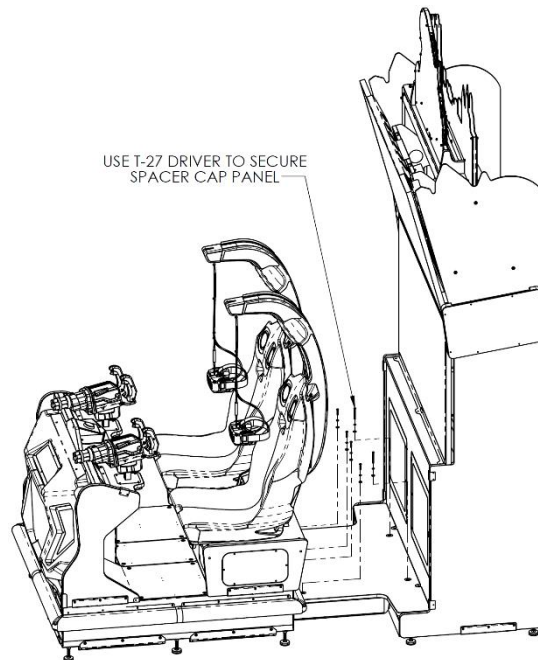

IMAGE 10-3

4. Lower all leg levelers to floor. There are (4) leg levelers on the monitor cabinet and (7) on the motion platform. Once leg levelers are done, raise the jam nuts on leg levelers up to mounting plate's weld nuts.

Godzilla Kaiju Wars VR™

Card Reader Installation and Setup

Due to the rising popularity of aftermarket debit card systems for cashless or coinless operation of amusement machines (i.e., Embed, Intercard, Semnox), this Godzilla Kaiju Wars VR™ cabinet is equipped with UCL compatible harnessing to ensure that the installation process is easier and less prone to miswiring.

UCL, or Universal Card Link, is a debit card standard established by the American Amusement Machine Association. Visit <https://coin-op.org/standardization/> for the latest UCL standard and manual information.

The UCL connections on the game use pins 1, 2, 6, 8, and 9. The other pins are unused. Each UCL connector can supply up to 1A at 12VDC.

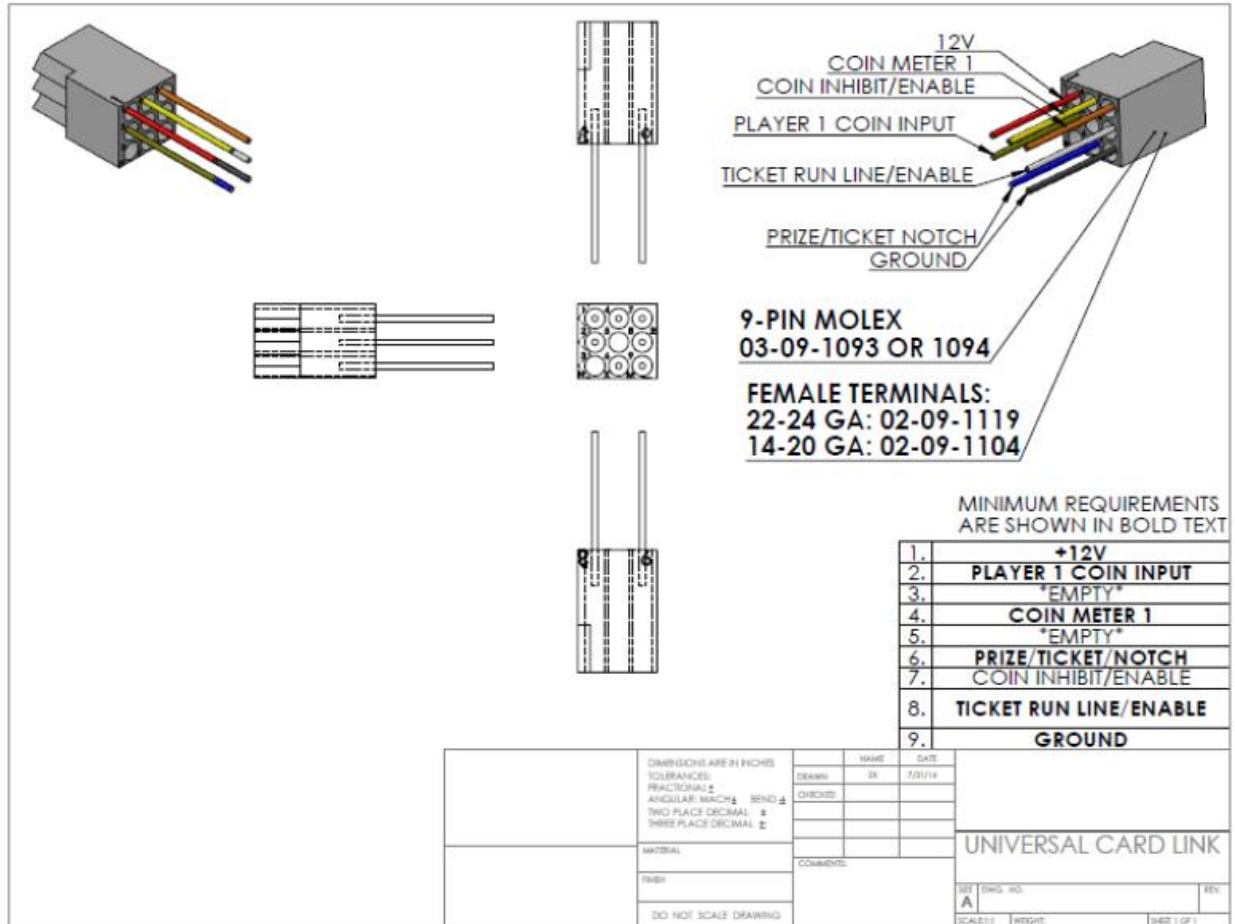

You can choose to use 1 or 2 card readers in the pricing adjustments section of the test menu. It is recommended to use 2 card readers for best results and player access.

There are (2) supplied connections, each located under the control panel of the Front Cabinet assembly. There is enough slack to accommodate mounting (2) card readers on the front panels, as each operator desires.

If only (1) card reader will be used, it is recommended that the card reader be mounted to the center dash door, any UCL connection can be used for games equipped with only (1) card reader.

Godzilla Kaiju Wars VR™

Check Electrical Settings

1. Verify the voltage in the nearest AC outlet.
2. Verify the AC outlet ground connection is present and working.

*****Recommended: Dedicated 20A circuit breaker for each line cord to prevent capacity overload. (10A/each for 230VAC)*****

Startup Game

1. Plug the two line cords into an AC outlet (**Recommended: plug each line cord into a dedicated 20A circuit breaker to prevent capacity overload. (10A/each for 230VAC)**)
2. Turn the main cabinet power switches on (there are two switches, GAME and COMPRESSOR).
3. Calibrate the headsets (pgs. 31-35)
*****MACHINE IS NOT OPERATIONAL WITHOUT FIRST CALIBRATING THE HARDWARE*****
4. Verify the game and all components are operating normally. See *Basic Functional Test on Initial Power Up* in the *Diagnostics and Adjustments* section for the recommended procedure.

Godzilla Kaiju Wars VR™

Monitor Setup

*****IMPORTANT*****

PLEASE FOLLOW INSTRUCTIONS TO SET UP MONITOR

Applicable Samsung monitors:

Model # QB65C ***120V & 230V***

STEP 1: Verify game is connected to monitor in HDMI IN 1 at rear of monitor.

STEP 2: Power on GAME cabinet and MONITOR, wait about 30 seconds.

STEP 3: Press the power button on the remote. This only needs to be done once during initial setup.

1. Language => "Hello" (English)
2. Set Up Network => Skip
3. Installation Type => [x] Manual Setup
4. Display Orientation => [x] Landscape
5. Player Selection => [x] MagicINFO S Player
6. Set Current Time => Set to current local time
7. Set Pin => Optional, but recommended

STEP 4: Press the "SOURCE" button on the remote. Navigate to "HDMI 1."

STEP 5: Press "MENU" on the remote to enter the settings menu.

STEP 6: Verify the settings below, navigating with the remote:

- System
 - Power Control
 - Auto Power On: ON [X]
 - Max. Power Saving: OFF
 - Standby Control: OFF
 - Remote Configuration: OFF
 - Power Button: Power On Only
 - Power and Energy Saving
 - Energy Saving Solution: OFF
 - Backlight Optimization: OFF
 - Backlight Schedule: OFF
 - No Signal Power Off: OFF
 - Auto Power Off: OFF
 - General
 - Game Mode: ON [X]
 - Touch Control
 - Admin Menu Lock: ON [X]
 - Security
 - Safety Lock On: ON [X]
 - USB Auto Play Lock: ON [X]
 - Mobile Connection Lock: ON [X]

Godzilla Kaiju Wars VR™

Monitor Setup Continued

*****IMPORTANT*****

PLEASE FOLLOW INSTRUCTIONS TO SET UP MONITOR

Applicable LG monitors:

Model # 65UR340C ***120V ONLY***

STEP 1: Verify game is connected to monitor in HDMI IN 1 at rear of monitor.

STEP 2: Power on GAME cabinet and MONITOR, wait about 30 seconds.

STEP 3: Press the power button on the remote. Set the language and location to match the cabinet's location.

STEP 4: Press the "LINE IN" button on the remote. Navigate to "HDMI 1."

STEP 5: Press "MENU" on the remote to enter the settings menu.

STEP 6: Verify the settings below, navigating with the remote:

- All Settings
 - Picture
 - Select Mode: Game Optimizer
 - Advanced Settings => Brightness: 62
 - General
 - Game Optimizer:
 - ON: [x] Enable
 - Game Genre: Standard Mode
 - System
 - Input Manager
 - HDMI 1: PC

STEP 7: Hold the "SETTINGS" button for 5 seconds until a grey stripe with "HDMI 1" appears on top.

STEP 8: Quickly press "1105" and then "OK" to enter a hidden menu. This must be done before "HDMI 1" disappears.

STEP 9: Verify the settings below, navigating with the remote:

- Public Display Setting
 - ON: [x] Enabled
 - Power On Status: PWR
 - Volume: OFF
 - Power On Default
 - ON: [x] Enable
 - Input: HDMI 1
 - Power Management: OFF
- General
 - Configuration Setup
 - USB Auto Playback: Disable
 - No Signal Image: OFF

Godzilla Kaiju Wars VR™

Headset Calibration Guide

*****MACHINE IS NOT OPERATIONAL WITHOUT FIRST CALIBRATING THE HARDWARE*****

1. In the test menu, select the “Calibration” menu item. (see below)

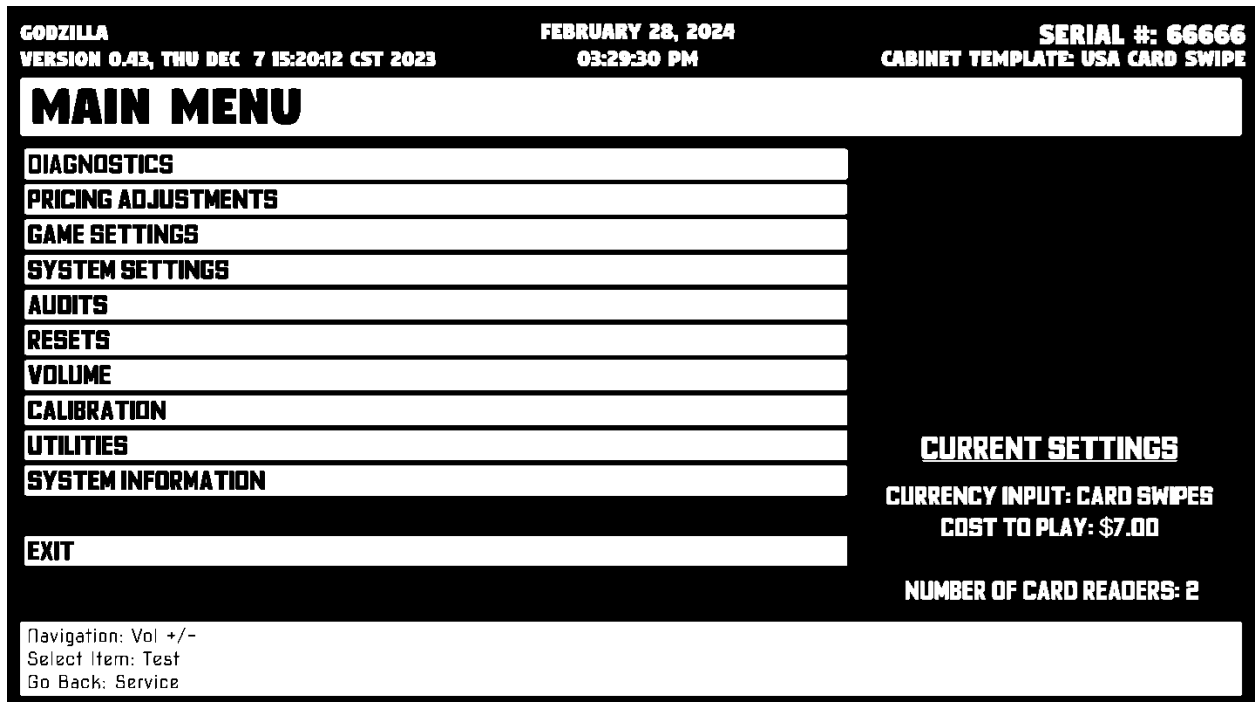

2. In the Calibration menu, select “Headset Calibration – P1”. (see below)

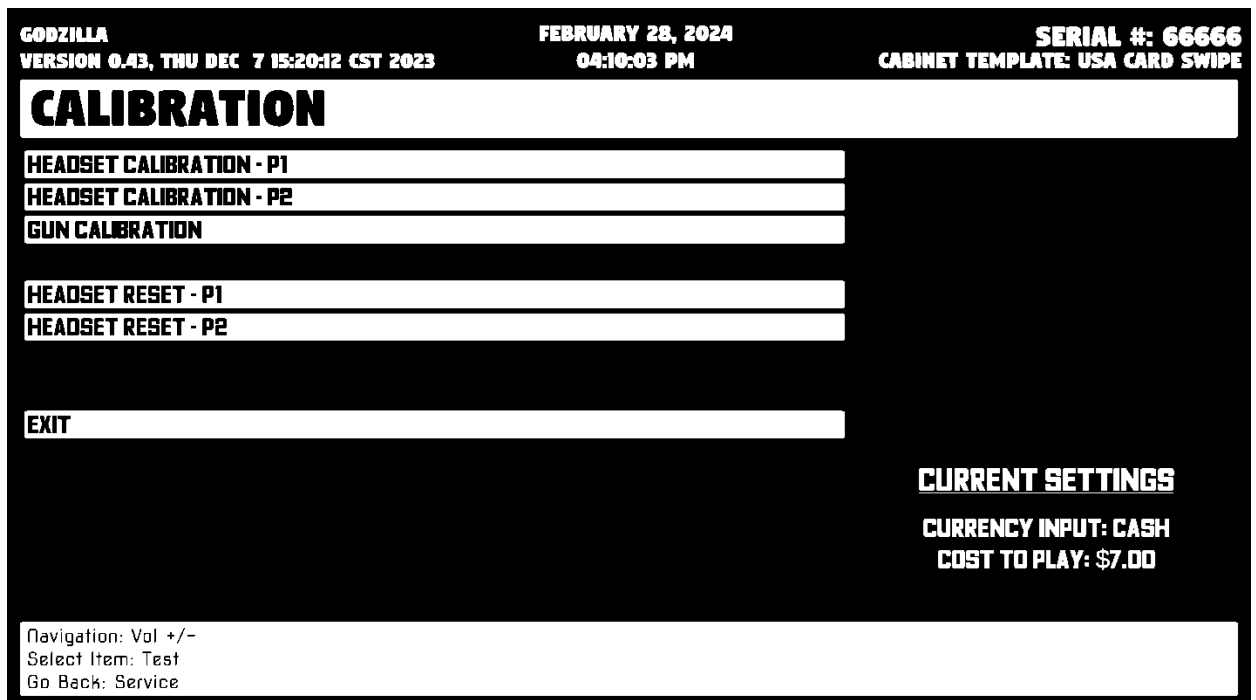

Godzilla Kaiju Wars VR™

3. Press **Test/Motion or Stop/Start** to begin calibration. (see below)

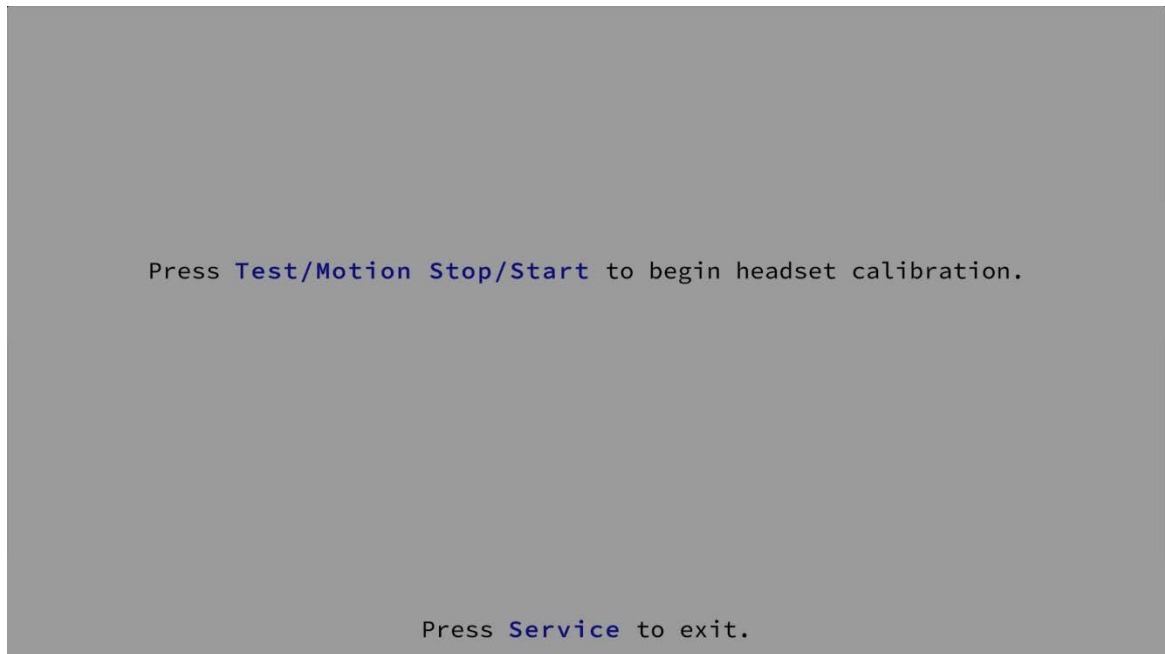

4. Sit down in the Player 1 seat and place the Player 1 headset on your head making sure that the cameras remain uncovered. (see below)



Godzilla Kaiju Wars VR™

5. With the headset on and while seated follow the in-headset instructions (*image a*). (**IMPORTANT: MAKE SURE THE HEADSET CAMERAS ARE NOT COVERED**).

*****IMPOTANT: DO NOT WALK AROUND WITH THE HEADSET ON*****

*****STAY SEATED TO PERFORM THE 360° LOOK AROUND*****

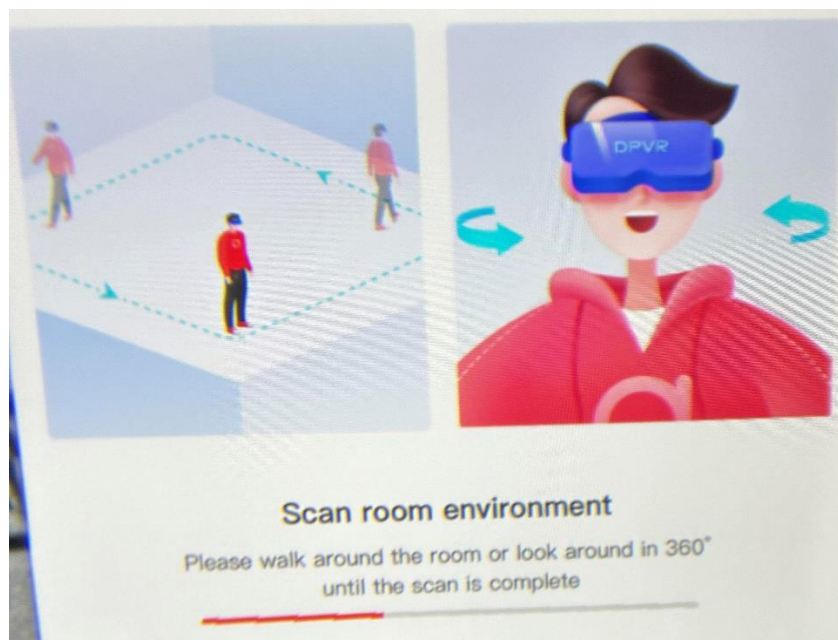
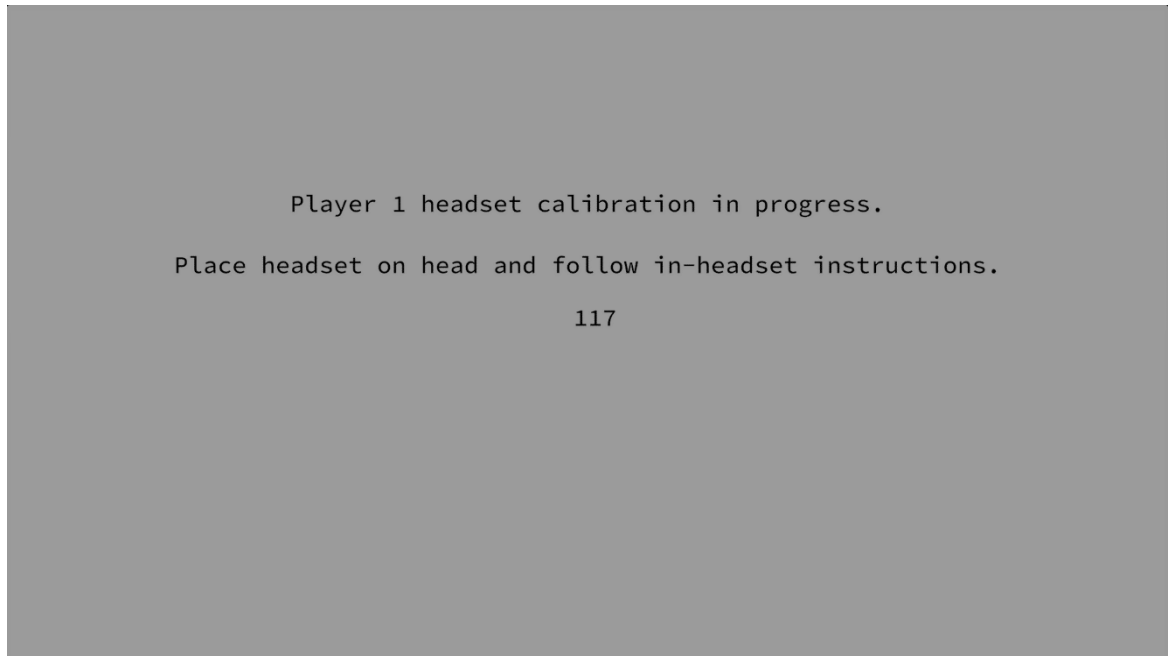
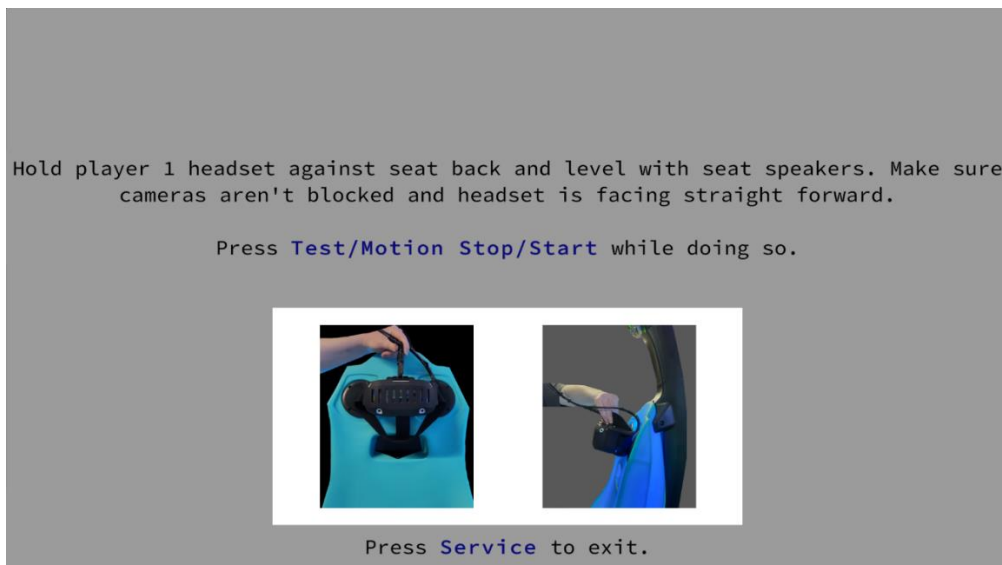
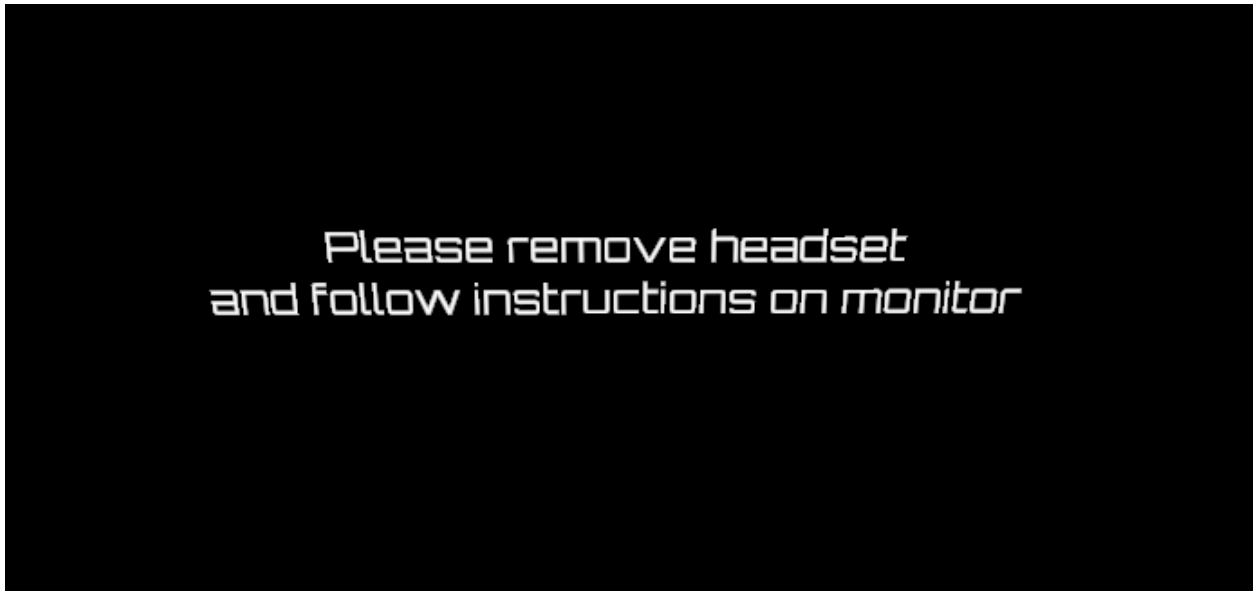

image a

Godzilla Kaiju Wars VR™

6. Remove headset and hold Player 1 headset against seat back and level with seat speakers. Make sure cameras aren't blocked and headset is facing straight forward. (see below). Press Test/Motion or Stop/Start while doing so.



Godzilla Kaiju Wars VR™

7. Player 1 headset should now be centered in the driver's seat of the vehicle. Please put on the headset to confirm. (see below)



8. Perform steps 2-7 with the Player 2 headset. Both headsets should now be calibrated.

Diagnostics and Adjustments

The Service Button Panel has four buttons, three of which can navigate the menu system.

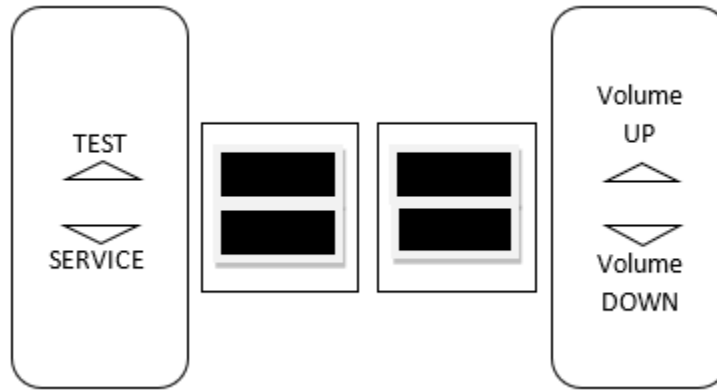

Navigating the Test Menu	
Button	Action
TEST (Not in Test Menu)	Enters Test Menu
TEST (In Test Menu)	Selects Highlighted Option
SERVICE (On Main Menu)	Exits Test Menu
SERVICE (Not on Main Menu)	Cancels Selection
VOLUME UP	Move Up
VOLUME DOWN	Move Down

An on-screen message acknowledges changes or when you exit a selection without making a change.

Godzilla Kaiju Wars VR™

Basic Functional Test on Initial Power Up

1. Enter the Input Test and verify all switch inputs are working.
2. Enter the Video Test and verify the monitors are working properly.
3. Enter the Audio Test and verify the audio works and is not distorted.
4. Enter the Cabinet Light Test and verify that all the lights are working properly.
5. Enter the Meter Test and verify the coin meter is working properly.
6. Enter the Motion Test and verify the motion platform is working properly.
 - a. Enter the Motion Stress Test to perform a stress test of the motion platform.
7. Enter the Blower Test and verify that both air blowers are working properly.
8. Enter the Watchdog Test and verify the game reboots.
9. Upon a successful reboot, you are ready to adjust pricing, volume, and other functions.

Godzilla Kaiju Wars VR™

Test Menus

Main Menu

Choose from all available operator settings and menus here. You can use the test menu bracket and volume buttons to navigate.

GODZILLA KAIJU WARS VR VERSION 0.00, UNKNOWN	MARCH 14, 2024 08:42:44 AM	SERIAL #: XXXX CABINET TEMPLATE: NOT SET
MAIN MENU		
FACTORY SET UP	Pick a pre-set combo of settings.	
DIAGNOSTICS		
PRICING ADJUSTMENTS	CURRENT SETTINGS CURRENCY INPUT: CASH COST TO PLAY: \$1.00	
GAME SETTINGS		
SYSTEM SETTINGS		
AUDITS		
RESETS		
VOLUME		
CALIBRATION		
UTILITIES		
SYSTEM INFORMATION		
EXIT		
Navigation: Vol +/- Select Item: Test Go Back: Service		

*****A QR code is provided in the test menu that will take you to our web site for the latest Troubleshooting Guide*****

Godzilla Kaiju Wars VR™

Diagnostics

Verify or diagnose the operations of all game functions.

GODZILLA	FEBRUARY 28, 2024	SERIAL #: 6666
VERSION 0.43, THU DEC 7 15:20:12 CST 2023	03:34:19 PM	CABINET TEMPLATE: USA CARD SWIPE
DIAGNOSTICS		
INPUT TEST		
GUN SOLENOID TEST		
GUN TRACKING TEST		
HEADSET STATUS		
HEADSET CAMERA TEST		
VIDEO TEST		
AUDIO TEST		
CABINET LIGHTS TEST		
METER TEST		
MOTION TEST		
BLOWER TEST		
WATCHDOG TEST		
EXIT		
Navigation: Vol +/- Select Item: Test Go Back: Service		CURRENT SETTINGS CURRENCY INPUT: CARD SWIPES COST TO PLAY: \$7.00 NUMBER OF CARD READERS: 2

- **Input Test:** Test input hardware such as switches.
- **Gun Solenoid Test:** Test the gun vibrations of the solenoids.
- **Gun Tracking Test:** Test the tracking of both guns.
- **Headset Status:** See info related to display and tracking for both headsets.
- **Headset Camera Test:** Test the functionality of the four exterior cameras on the DPVR headset.
- **Video Test:** Cycle through full screen colors on the monitor.
- **Audio Test:** 100HZ and 1000HZ test.
- **Cabinet Lights Test:** Tests all LED cabinet lighting together and individually.
- **Meter Test:** Test the functionality of the mechanical coin meter inside the cabinet.
- **Motion Test:** Test the functionality of the motion platform.
- **Blower Test:** Test the functionality of the two blowers.
- **Watchdog Test:** Test the functionality of the watchdog reset. (If successful the cabinet will power off and reboot)

Godzilla Kaiju Wars VR™

Set Pricing Adjustments (Cash)

Set pricing adjustments using cash and coin currency for game operation.

GODZILLA		FEBRUARY 29, 2024	SERIAL #: 6666
VERSION 0.43, THU DEC 7 15:20:12 CST 2023		08:29:44 AM	CABINET TEMPLATE: USA CARD SWIPE
PRICING ADJUSTMENTS			
CURRENCY INPUT	CASH		Change the currency input.
CURRENCY TYPE	US DOLLARS		
COIN VALUE	\$0.25		
NUMBER OF CASHBOXES	1		
COINS TO PLAY	28		
MAX CREDITS	30		
FREE PLAY	OFF		
EXIT			CURRENT SETTINGS
			CURRENCY INPUT: CASH
			COST TO PLAY: \$7.00
Navigation: Vol +/- Select Item: Test Go Back: Service			

- **Currency Input:** Change the currency input.
- **Currency Type:** Change the currency type.
- **Coin Value:** Change the money value of the coin.
- **Number of Cashboxes:** Whether players share a cashbox, or each have their own.
- **Coins to Play:** Adjust the amount of coins to start a game.
- **Max Credits:** Adjust the maximum number of credits.
- **Free Play:** Turn free play mode on or off.

Godzilla Kaiju Wars VR™

Set Pricing Adjustments (Tokens)

Set pricing adjustments using non cash value game tokens for game operation.

GODZILLA		FEBRUARY 29, 2024		SERIAL #: 6666	
VERSION 0.43, THU DEC 7 15:20:12 CST 2023		08:29:44 AM		CABINET TEMPLATE: USA CARD SWIPE	
PRICING ADJUSTMENTS					
CURRENCY INPUT					TOKENS
CURRENCY TYPE					US DOLLARS
TOKEN VALUE					\$0.25
NUMBER OF CASHBOXES					1
TOKENS TO PLAY					28
MAX CREDITS					30
FREE PLAY					OFF
EXIT					
					CURRENT SETTINGS
					CURRENCY INPUT: TOKENS
					COST TO PLAY: \$7.00
Navigation: Vol +/- Select Item: Test Go Back: Service					

- **Currency Input:** Change the currency input.
- **Currency Type:** Change the currency type.
- **Token Value:** Change the money value of the token.
- **Number of Cashboxes:** Whether players share a cashbox, or each have their own.
- **Tokens to Play:** Adjust the number of tokens to start a game.
- **Max Credits:** Adjust the maximum number of credits.
- **Free Play:** Turn free play mode on or off.

Godzilla Kaiju Wars VR™

Set Pricing Adjustments (Swipes)

Set pricing adjustments using card based play systems for game operation.

GODZILLA		FEBRUARY 28, 2024		SERIAL #: 6666	
VERSION 0.43, THU DEC 7 15:20:12 CST 2023		02:52:13 PM		CABINET TEMPLATE: USA CARD SWIPE	
PRICING ADJUSTMENTS					
CURRENCY INPUT			CARD SWIPES		
CURRENCY TYPE			US DOLLARS		
SWIPE VALUE			\$7.00		
NUMBER OF CARD READERS			2		
MAX CREDITS			30		
FREE PLAY			OFF		
EXIT					
			CURRENT SETTINGS		
			CURRENCY INPUT: CARD SWIPES		
			COST TO PLAY: \$7.00		
			NUMBER OF CARD READERS: 2		
Navigation: Vol +/- Select Item: Test Go Back: Service					

- **Currency Input:** Change the currency input.
- **Currency Type:** Change the currency type.
- **Swipe Value:** Money value of the swipe.
- **Number of Card Readers:** Whether players share a cashbox, or each have their own. (DBV input is disabled when set to 2.)
- **Max Credits:** Adjust the maximum number of credits.
- **Free Play:** Turn free play mode on or off.

Godzilla Kaiju Wars VR™

Game Settings

Adjust game settings for operation.

GODZILLA		FEBRUARY 28, 2024		SERIAL #: 6666	
VERSION 0.43, THU DEC 7 15:20:12 CST 2023		04:00:20 PM		CABINET TEMPLATE: USA CARD SWIPE	
GAME SETTINGS					
CHAPTER 1 ENABLED		ON	Allow the Chapter 1 level to be selected and played.		
CHAPTER 2 ENABLED		ON			
SHOW HEADSET CAMERA FEED DURING CONTINUE		ON			
DIFFICULTY		NORMAL			
HIDE FEMALES		OFF			
ATTRACT MUSIC FREQUENCY		ALWAYS			
FREE DEMO		ON	CURRENT SETTINGS CURRENCY INPUT: CASH COST TO PLAY: \$7.00		
TIME BETWEEN FREE DEMOS [MINUTES]		2			
EXIT					
Navigation: Vol +/- Select Item: Test Go Back: Service					

- **Chapter 1 Enabled:** Allow the Chapter 1 level to be selected and played.
- **Chapter 2 Enabled:** Allow the Chapter 2 level to be selected and played.
- **Show Headset Camera Feed During Continue:** Whether player should see a view of the exterior headset cameras during continue.
- **Difficulty:** Adjust the game difficulty.
- **Hide Females:** This option removes all images of females from the game (for localization or cultural reasons).
- **Attract Music Frequency:** How often music should play in attract mode.
- **Free Demo:** Whether players should be given a 30 second free demo when the cabinet is not in use.
- **Time Between Free Demos [Minutes]:** After a free demo has been completed, how long before another can be started.

Godzilla Kaiju Wars VR™

System Settings

Adjust system settings for operation.

GODZILLA		FEBRUARY 28, 2024		SERIAL #: 6666	
VERSION 0.43, THU DEC 7 15:20:12 CST 2023		02:04:21 PM		CABINET TEMPLATE: USA CARD SWIPE	
SYSTEM SETTINGS					
LEADERBOARD SETTINGS					
SHOW COMPRESSOR ERRORS					OFF
SHOW PRESSURE WARNINGS					OFF
CABINET LED BRIGHTNESS					MAX
TRADESHOW MODE					OFF
CABINET MOTION ENABLED					ON
BLOWER ENABLED					ON
VIRTUAL MARQUEE					OFF
QR CODE					
DATE & TIME					2/28/2024 4:04:21 PM
LANGUAGE					ENGLISH
SUBTITLES					OFF
PLAYER 1 HEADSET ENABLED					
					ENABLED
PLAYER 2 HEADSET ENABLED					
					ENABLED
EXIT					
Navigation: Vol +/- Select Item: Test Go Back: Service					

Leaderboard Adjustments.

CURRENT SETTINGS

CURRENCY INPUT: CASH

COST TO PLAY: \$7.00

- **Leaderboard Settings:** Leaderboard Adjustments.
- **Show Compressor Errors:** Toggle whether messages about compressor errors will be shown on monitors.
- **Show Pressure Warnings:** Toggle whether warnings related to compressor pressure will be shown on monitors.
- **Cabinet LED Brightness:** Adjust the brightness of the cabinet lighting.
- **Tradeshow Mode:** Turn this mode on when operating on a trade show, sales floor, or demo floor.
- **Cabinet Motion Enabled:** Enable motion springs.
- **Blower Enabled:** Enable the blower fans in game.
- **Virtual Marquee:** Show a game title marquee at the top of the screen during attract and gameplay.
- **QR Code:** Turn on/off the QR code feature, set venue name and location.
- **Date & Time:** Set the date and time.
- **Language:** Set language: English, Chinese, Traditional Chinese, Spanish (Latin America), Spanish (Spain), French, German, Italian, and Japanese.
- **Subtitles:** In game subtitles (ON/OFF).
- **Player 1 Headset Enabled:** Allows the player 1 headset to be disabled if it is not present or is having technical issues.
- **Player 2 Headset Enabled:** Allows the player 2 headset to be disabled if it is not present or is having technical issues.

Godzilla Kaiju Wars VR™

Audits

View machine statistics such as games played, money earned, etc.

GODZILLA	FEBRUARY 28, 2024	SERIAL #: 6666																												
VERSION 0.43, THU DEC 7 15:20:12 CST 2023	04:08:20 PM	CABINET TEMPLATE: USA CARD SWIPE																												
AUDITS																														
PAGE 1 OF 19																														
0.43 Wednesday, February 28, 2024 4:10:16 PM Last Audit Reset: Wednesday, February 28, 2024 3:57:55 PM ----- COIN AUDITS <table style="width: 100%; border-collapse: collapse;"> <tr> <td>All Cashboxes Combined - Money In</td> <td style="text-align: right;">\$0.00</td> </tr> <tr> <td>All Cashboxes Combined - Money Spent</td> <td style="text-align: right;">\$0.00</td> </tr> <tr> <td>All Cashboxes Combined - Money Unspent</td> <td style="text-align: right;">\$0.00</td> </tr> <tr> <td>Total Coins From All Inputs</td> <td style="text-align: right;">0</td> </tr> <tr> <td colspan="2"> </td> </tr> <tr> <td>P1 cashbox - Money In</td> <td style="text-align: right;">\$0.00</td> </tr> <tr> <td>P1 cashbox - Money Spent</td> <td style="text-align: right;">\$0.00</td> </tr> <tr> <td>P1 cashbox - Money Unspent</td> <td style="text-align: right;">\$0.00</td> </tr> <tr> <td>Coins From Input 1</td> <td style="text-align: right;">0</td> </tr> <tr> <td colspan="2"> </td> </tr> <tr> <td>P2 cashbox - Money In</td> <td style="text-align: right;">\$0.00</td> </tr> <tr> <td>P2 cashbox - Money Spent</td> <td style="text-align: right;">\$0.00</td> </tr> <tr> <td>P2 cashbox - Money Unspent</td> <td style="text-align: right;">\$0.00</td> </tr> <tr> <td>Coins From Input 2</td> <td style="text-align: right;">0</td> </tr> </table>			All Cashboxes Combined - Money In	\$0.00	All Cashboxes Combined - Money Spent	\$0.00	All Cashboxes Combined - Money Unspent	\$0.00	Total Coins From All Inputs	0			P1 cashbox - Money In	\$0.00	P1 cashbox - Money Spent	\$0.00	P1 cashbox - Money Unspent	\$0.00	Coins From Input 1	0			P2 cashbox - Money In	\$0.00	P2 cashbox - Money Spent	\$0.00	P2 cashbox - Money Unspent	\$0.00	Coins From Input 2	0
All Cashboxes Combined - Money In	\$0.00																													
All Cashboxes Combined - Money Spent	\$0.00																													
All Cashboxes Combined - Money Unspent	\$0.00																													
Total Coins From All Inputs	0																													
P1 cashbox - Money In	\$0.00																													
P1 cashbox - Money Spent	\$0.00																													
P1 cashbox - Money Unspent	\$0.00																													
Coins From Input 1	0																													
P2 cashbox - Money In	\$0.00																													
P2 cashbox - Money Spent	\$0.00																													
P2 cashbox - Money Unspent	\$0.00																													
Coins From Input 2	0																													
CURRENT SETTINGS CURRENCY INPUT: CABH COST TO PLAY: \$7.00																														
Navigation: Vol +/- or Start Buttons [P1 scrolls up and P2 scrolls down] Go Back: Service																														

*****Changes to pricing adjustments will reset any existing audits back to zero*****

Godzilla Kaiju Wars VR™

Resets

Reset various machine settings and audits.

GODZILLA **FEBRUARY 28, 2024** **SERIAL #: 6666**
VERSION 0.43, THU DEC 7 15:20:12 CST 2023 **04:08:43 PM** **CABINET TEMPLATE: USA CARD SWIPE**

RESETS MENU

- RESET CREDITS
- RESET PRICING ADJUSTMENTS
- RESET GAME ADJUSTMENTS
- RESET LEADERBOARDS
- RESET GAME AUDITS
- RESET SYSTEM AUDITS
- RESET COIN AUDITS
- RESET ALL AUDITS
- FACTORY RESTORE

Reset all credits to zero.

CURRENT SETTINGS
CURRENCY INPUT: CASH
COST TO PLAY: \$7.00

EXIT

Navigation: Vol +/-
Select Item: Test
Gu Back: Service

- **Reset Credits:** Reset all credits to zero.
- **Reset Pricing Adjustments:** Reset all pricing settings to default.
- **Reset Game Adjustments:** Reset all game settings to default.
- **Reset Leaderboards:** Reset all high score tables.
- **Reset Game Audits:** Reset all game related audits.
- **Reset System Audits:** Reset all system audits.
- **Reset Coin Audits:** Reset all coin audits.
- **Reset All Audits:** Reset all audits.
- **Factory Restore:** Restore game to all factory settings.

*****HEADSET CALIBRATION AND PRICING ADJUSTMENTS MUST BE PERFORMED AGAIN IF THE GAME HAS BEEN RESTORED TO FACTORY SETTINGS*****

Godzilla Kaiju Wars VR™

Volume

Adjust all volume settings.

GODZILLA		FEBRUARY 28, 2024		SERIAL #: 6666	
VERSION 0.43, THU DEC 7 15:20:12 CST 2023		04:09:07 PM		CABINET TEMPLATE: USA CARD SWIPE	
VOLUME					
GAME VOLUME		18/25	Adjust the volume during gameplay.		
ATTRACT VOLUME		0/25			
CREDIT VOLUME		15/25			
EXIT					
CURRENT SETTINGS					
CURRENCY INPUT: CASH					
COST TO PLAY: \$7.00					
Navigation: Vol +/- Select Item: Test Go Back: Service					

- **Game Volume**: Adjusts the volume level during gameplay.
- **Attract Volume**: Adjusts the volume level during the attract mode sequences.
- **Credit Volume**: Adjusts the volume level of the credit chime only (independent setting of game and attract volume).

Godzilla Kaiju Wars VR™

Calibration

Calibrate the VR headsets and cabinet motion.

*****MACHINE IS NOT OPERATIONAL WITHOUT FIRST CALIBRATING THE HARDWARE*****

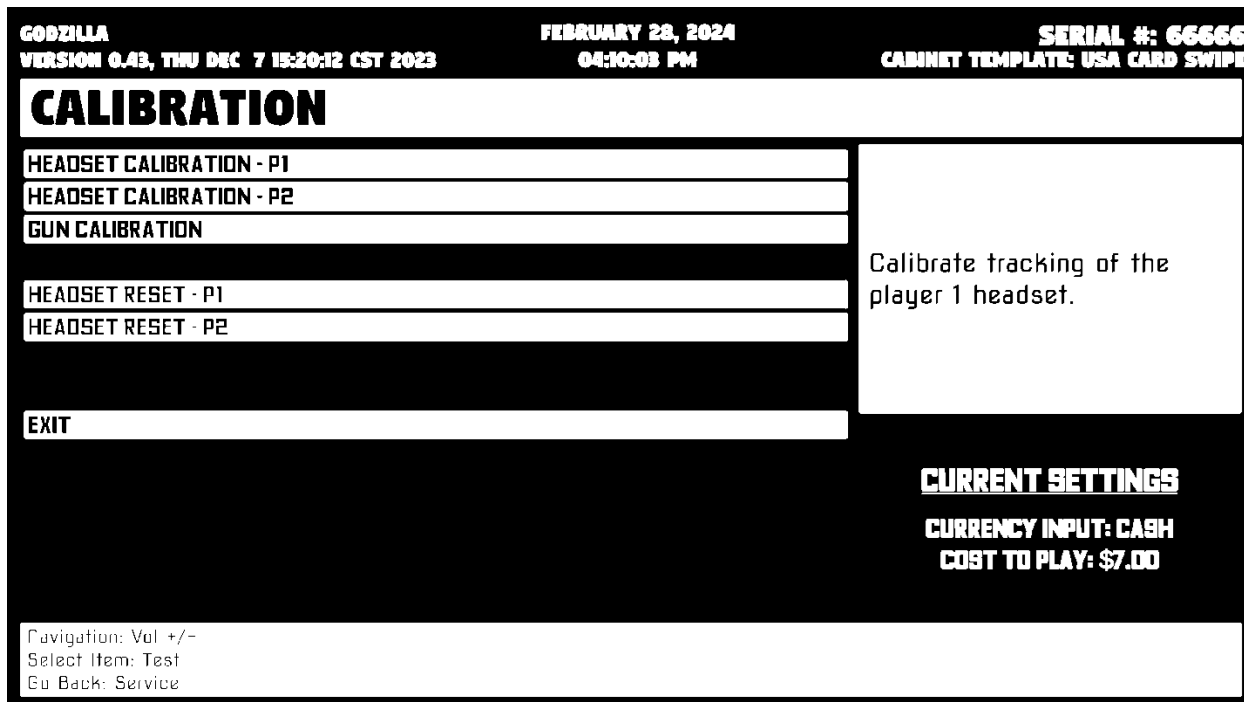

- **Headset Calibration – P1**: Calibrate tracking of the Player 1 headset.¹
- **Headset Calibration – P2**: Calibrate tracking of the Player 2 headset.¹
- **Gun Calibration**: Calibrate the gun sights and reticle.
- **Headset Reset – P1**: Attempt to reset the player 1 DPVR headset if it is having issues.
- **Headset Reset – P2**: Attempt to reset the player 2 DPVR headset if it is having issues.

¹ See Headset Calibration Guide, pgs. 31-35

Godzilla Kaiju Wars VR™

Utilities

Miscellaneous operator tools.

GODZILLA
VERSION 0.43, THU DEC 7 15:20:12 CST 2023

FEBRUARY 28, 2024
02:14:02 PM

SERIAL #: 6666
CABINET TEMPLATE: USA CARD SWIPE

UTILITIES

- COPY AUDITS, LOGS, & SCORES TO USB
- VIEW GAME LOG
- VIEW ERROR LOG
- VIEW UNITY LOG
- QR CODE SERVICE INFO
- EXIT

Copy all audits and diagnostics to USB drive.

CURRENT SETTINGS
CURRENCY INPUT: CASH
COST TO PLAY: \$7.00

Navigation: Vol +/-
Select Item: Test
Go Back: Service

- **Copy Audits, Logs, & Scores to USB**: Copy all audits and diagnostics to USB drive.
- **View Game Log**: Examine logged messages from the game.
- **View Error Log**: Examine error messages from the game.
- **View Unity Log**: Examine logged messages from Unity.
- **QR Code Service Info**: Send Diagnostics Info to Raw Thrills via cell phone QR scanner.

Godzilla Kaiju Wars VR™

System Information

View hardware and software information

GODZILLA
VERSION 0.43, THU DEC 7 15:20:12 CST 2023FEBRUARY 28, 2024
04:15:53 PMSERIAL #: 6666
CABINET TEMPLATE: USA CARD SWIPE

SYSTEM INFORMATION

PAGE 1 OF 3

Serial Number: 66666 CabinetType: 1 Template: 0 Region: 1 Version: 0
IO Board AD30EH73H Firmware Version: 9
IO Board B Firmware Version: 0
Rio2 Lib Version: v1.8.9
Operating System Version: OS Version Unknown

GVR-4060Z Model: 11TMS1XG00 (LENOVO)
DeviceUniqueIdentifier: 14b684e5d82dc8d9673d996d0b94c1c12ec75d16
CPU: 12th Gen Intel(R) Core(TM) i5 12500 [12 cores]
RAM: 16099 MB
Graphics Card: NVIDIA GeForce RTX 4060 VRAM: 7971
Graphics API: Direct3D 11.0 [Level 11.1] Type=Direct3D11
2022.3.7f1
Screen: 1920x1080@60Hz
OS: Windows 10 (10.0.19045) 64bit [Desktop]

Supported Resolutions:
Total Supported Res: 60

(640, 480)	(640, 480)	(600, 800)	(640, 480)	(720, 480)
(480, 720)	(720, 480)	(720, 576)	(800, 600)	(800, 600)
(800, 600)	(800, 600)	(480, 720)	(1024, 768)	(1024, 768)
(1024, 768)	(1152, 864)	(1176, 664)	(480, 640)	(480, 640)

CURRENT SETTINGS

CURRENCY INPUT: CABH

COST TO PLAY: \$7.00

Go Back: Service

There are no special menu options for this test menu entry.

Godzilla Kaiju Wars VR™

Choosing the Right Pricing Adjustments for Your Location

Card Swipe Locations

- Make Sure Your Game is Set to **Swipes Mode**:
 1. Hold the Test Button for 2 seconds to enter the Test Menu.
 2. Select “Pricing Adjustments” from the menu.
 3. Select “Currency Input” from the menu.
 4. Select “Card Swipes” from the menu.
 5. Exit out of “Currency Input” menu.
 6. While back in “Pricing Adjustments” menu, set “Swipe Value” to the currency equivalent of your swipe, or the coin audits bookkeeping will be incorrect. (Example: If the card swipe is worth \$1.50 in your card system, set the swipe value to \$1.50 as well).

Coin Locations

- Make Sure Your **Pricing & Coin Value** are Correct:
 1. Hold the Test Button for 2 seconds to enter the Test Menu.
 2. Select “Pricing Adjustments” from the menu.
 3. Select “Currency Input” from the menu.
 4. Select “Cash” or “Tokens” from the menu.
 5. Exit out of “Currency Input” menu.
 6. While back in “Pricing Adjustments” menu
 - a. Select “Coins to Play” and set the desired amount of coins per game of *Godzilla Kaiju Wars VR™*.
 - b. After setting the coins per play, set “Coin Value” to the currency equivalent of your coin, or the coin audits bookkeeping will be incorrect. (Example: If your coin is worth \$0.25, set “Coin Value” to \$0.25 as well).

Godzilla Kaiju Wars VR™

PC Hardware

Your *Godzilla Kaiju Wars VR™* game uses two **Lenovo M90t Gen3 Desktop PC computers with an RTX 4060 Video Card**. One is the Player 1 PC and the other is the Player 2 PC.



(above: Lenovo M90t Gen3 Desktop PC)

NOTICE

WARNING: DO NOT ENTER THE BIOS SETTINGS MENU! Modifying the BIOS settings will cause your game to stop functioning. In order to boot, new security features verify the BIOS settings against factory settings, including timestamp.

Godzilla Kaiju Wars VR™

PC Hard Drive Recovery

Symptoms requiring a PC hard drive recovery include:

- File test reports bad or missing files.
- Game fails to finish loading during setup.
- After resetting the AC power, an error is reported.
- Erratic Game or Attract Mode behavior.

The only way to repair corrupt files is to reinstall the software as described below:

Computer

The computer contains sensitive components. Do not handle roughly. Contact your distributor before servicing its internal components. Ask about warranty information as it relates to the PC.

Do **not** use the PC on/off switch. Turn AC power on or off with the cabinet power switch.

Steps to Re-Install the software (the game ships with (2) USB drives, either drive can be used in the steps below):

(NO DVD Restoration. USB Thumb Drive is used on the *Lenovo M90t Gen3*)

1. With game and PC's on, verify that the RIO2 board has power. If not, see Troubleshooting.
2. Open the lower back door of the cabinet.
3. Insert the recovery USB thumb drive (included in your game) into an open USB port on the "Player 1 PC".
4. Plug in a USB keyboard to "Player 1 PC".
5. Turn cabinet power switch to OFF. Wait 30 seconds.
6. Turn cabinet power switch to ON, and **HOLD** F12 on the keyboard until the Boot Menu screen appears.
7. Use the Up and Down arrow keys to highlight "USB HDD 1" (or similar) and press enter.
8. Follow on screen instructions to begin recovery.
9. If recovery does not begin, check to ensure USB Drive is inserted correctly and is not damaged.
10. Initial software loading may take several minutes. Check progress periodically.
Do not interrupt power or reset the game during recovery.
11. When software has been loaded, a message indicates that restore is complete. When instructed to remove USB Drive, wait 15 seconds to remove the drive from the PC.
12. Turn cabinet power switch off.
13. Repeat steps 3-12 for the "Player 2 PC".
14. Turn the cabinet on again.
15. Your game will now be restored.

Godzilla Kaiju Wars VR™

Troubleshooting

Warning: Review the Safety section before making any adjustments to the game.

Problem	Possible Cause	Solution
Game will not power up.	Game not plugged in.	Plug game into AC outlet.
	Game not turned on.	Turn on main power switch.
	Game fuse is blown.	Check and replace fuse. See Specification section for fuse values.
	No power to receptacle.	Test AC outlet and plug game into powered outlet.
	PC BIOS set incorrectly.	Contact your distributor.
	Flash Drive Installer is left connected to PC.	Disconnect Flash Drive Installer and power cycle the game.
Buttons do not work.	Faulty micro switch.	Replace the micro switch on the button and re-test. Verify that the wires are connected to the correct spades on the micro switch.
	Faulty wiring.	Disconnect the cabinet from AC power. Verify that all wires are firmly connected to each button and the PCB. Verify that no wires are frayed or improperly shorting to ground. Verify that wires are connected to the correct spades on the micro switches.
	Faulty PCB.	Ensure all connections to PCB are secure. Replace PCB if faulty.
Neither buttons nor audio work.	PCB connected to faulty USB port (boot message may indicate not detected)	To test a USB port, turn off the game, disconnect the device from the port, and then connect the game dongle to the port. Reboot the game. A No Dongle message indicates the port is bad. If the game starts, the port is working. After the test, reconnect all devices to the correct USB ports and reboot.

Godzilla Kaiju Wars VR™

Problem	Possible Cause	Solution
No sound or bad sound.	Bad connection.	Check connection to speakers.
	Volume set too low.	Use VOL UP button on Test panel to raise volume
	Faulty wiring.	Verify all wires are firmly connected to the speakers and the audio PCB. Verify that audio PCB is connected to the computer via USB cable.
	Blown speakers.	Remove the grill and inspect each speaker for visible damage. Run the Sound Test from System Tests in the Operator Menu to verify each speaker is working.
	Reversed wires.	A weak or low muffled sound is a sign of reversed speaker wires. Check for reversed wires on each speaker.
Constant low audio hum.	Faulty power supply.	Check external DC supply and the PC supply.
	Open ground.	Check all ground wires in cabinet. Ensure AC wall outlet is properly grounded.
RIO2 disconnected	USB cable disconnected.	Check USB connection from PC to RIO2 board.
	No power to RIO2 board.	Check for proper voltage (+5V, +12V) at RIO2 P1 connector.
Game is not running on both PC's.	Not connected to other PC.	Make sure both PC's are on and are connected to headsets and displays. Make sure the game runs on both displays.
	Ethernet cable is not connected.	Connect the ethernet cable between the two computers.
No motion during gameplay.	Motion is not enabled.	Enable motion via Test Menu under System Settings.

Godzilla Kaiju Wars VR™

Problem	Possible Cause	Solution
Message on screen: Headset USB connection not detected.	Loose or disconnected USB cable.	Disconnect and reconnect the USB cable from the headset to the PC (must be plugged into a USB 3.0 port), then reboot the cabinet.
Message on screen: Headset Display Port not detected. Reconnect headset via Display Port.	Loose or disconnected display port cable.	Disconnect and reconnect the display port cable from the headset to the PC, then reboot the cabinet.
Message on screen: Game dongle not found. Please RECONNECT the game dongle.	Dongle missing or disconnected.	Find the dongle cable and reseal in USB port.
	Faulty USB port.	Insert dongle cable in different USB port.
Message on screen: Insufficient RAM, 16GB required.	Loose or disconnected RAM stick.	Contact your distributor for service.
	Faulty RAM stick.	Contact your distributor for service.
Message on screen: GFX card missing. Please RECONNECT the GFX card.	Loose or disconnected graphics card.	Contact your distributor for service.
	Faulty graphics card.	Contact your distributor for service.
Game does not load.	PC hard drive failure.	Recover hard drive. See Flash Installer Document or contact your distributor for the latest software revision.
PC Drive test reports "bad" or "missing" files.		
Game fails to finish loading.		
After resetting, game still reports an error.		
Erratic game mode or attract mode.		
WARNING! Data files Corrupted. (Game Operation May Become Unstable.)		
Game Resets	Bad file.	Run Flash Installer.

Godzilla Kaiju Wars VR™

Problem	Possible Cause	Solution
No Video	PC not turned on.	Turn PC power switch on. Ensure IEC cable tightly plugged in. Trace cable back to source to ensure continuity.
	Video cable not secure.	Check and secure DVI or HDMI connector to Monitor. Check and secure DVI or HDMI connector to PC.
	Cabinet was powered on too quickly after a manual shutdown/power loss	Shut off cabinet via both switches at rear of cabinet. Leave off for 30 seconds, then power back on.
Coin meter does not click during test.	No pulse to meter.	Check wiring from meter to PCB board.
	Faulty meter.	Replace coin meter.
Exits Test Mode every 3 seconds.	Test button stuck in ON position.	Slide or toggle button off after Test Menu appears
Improper number of credits given when bills are inserted.	Incorrect setting in Pricing Adjustments.	Adjust pricing settings.
	Faulty wiring.	Disconnect cabinet from AC power. Verify wires are firmly connected to bill validator and ground wires are properly connected. Verify no wires are frayed or shorting to ground.
Compressor does not turn on/low humming noise coming from the compressor	Compressor power cut off while it was running.	Shut off cabinet via both switches at rear of cabinet. Leave off for 3 minutes, then power back on.

Godzilla Kaiju Wars VR™

Problem	Possible Cause	Solution
<p>There is no positional (X,Y,Z) tracking of head movements.</p>	<p>Headset needs to be calibrated.</p>	<p>Please see Headset Calibration Guide, pgs. 31-35</p>
<p>The view within the headset is disoriented.</p>		
<p>Headset does not power on/one or both viewports display a black screen.</p>	<p>Loose connection.</p>	<p>Reseat connection at headset and PC. If the problem persists, contact your distributor to order a replacement.</p>



For the latest troubleshooting tips please visit our website at www.rawthrills.com/service/godzilla-kaiju-wars-vr-support/

Godzilla Kaiju Wars VR™

Technical Support

Betson's Raw Thrills Technical Support Hotline

Phone: 1-800-753-2513

FAX: 1-201-438-5019

Email: rtsupport@betson.com



For an authorized distributor near you, check the Raw Thrills website at www.rawthrills.com/sales/



For Sales, Game Registration, Support and Software Please Visit Our Web Site: www.rawthrills.com/service/

Electrical and Mechanical Illustrations

Pgs. 62-63 – Game Assembly

Pg. 64 – Motion Platform Assembly

Pg. 65 – Motion Platform Mechanism Sub-Assembly

Pg. 66 – Base Platform Sub-Assembly

Pg. 67 – Motion Platform Skirt Sub-Assembly

Pg. 68 – Top Platform Sub-Assembly

Pgs. 69-70 – Control Cabinet Sub-Assembly

Pg. 71 – Front Vacform Sub-Assembly

Pg. 72 – Mini Blower Sub-Assembly

Pg. 73 – Dash Dual Speaker Sub-Assembly

Pg. 74 – Blower Cover Sub-Assembly

Pg. 75 – Center Motion Stop Sub-Assembly

Pg. 76 – Gun Access Plate Sub-Assembly

Pgs. 77-78 – Seat Cabinet Sub-Assembly

Pgs. 79-80 – Seat Sub-Assembly

Pg. 81 – Inner Seat LED Sub-Assembly

Pg. 82 – Headset Rack Sub-Assembly

Pg. 83 – Headset Edgeglow Sub-Assembly

Pg. 84 – Woofer Sub-Assembly

Pg. 85 – Seat Center Mask Holder Sub-Assembly

Pg. 86 – Mask Holder Bracket Sub-Assembly

Pg. 87 – Spacer Bracket Sub-Assembly

Pg. 88 – Manifold Sub-Assembly

Pgs. 89-90 – Monitor Cabinet Sub-Assembly

Godzilla Kaiju Wars VR™

Pg. 91 – Right Logo Lightbox Sub-Assembly

Pg. 92 – Relay/Filter/Inlet Sub-Assembly

Pg. 93 – PC Shelf Sub-Assembly

Pg. 94 – Compressor Monitor PCB/Compressor Fan/Filter-Regulator Sub-Assembly

Pg. 95 – Compressor Shelf/Compressor Drain Solenoid Valve Sub-Assembly

Pg. 96 – 230V Compressor Shelf Sub-Assembly

Pg. 97 – Access Door Sub-Assembly

Pg. 98 – RIO2 Sub-Assembly

Pg. 99 – Upper Monitor Hanger Sub-Assembly

Pgs. 100-101 – Topper Sub-Assembly

Pg. 102 – Platform Downlighting Assembly

Pg. 103 – Back Door Assembly

Pg. 104 – Spacer Cap Assembly

Pgs. 105-107 – DPVR Headset Assembly

Pgs. 108-110 – Gun Main Assembly

Pg. 111 – Gun Pot Alignment Assembly

Pg. 112 – Gun Grip Assembly

Pg. 113 – Gun Cover & Tip Assembly

Pgs. 114-124 – Electrical System Diagrams

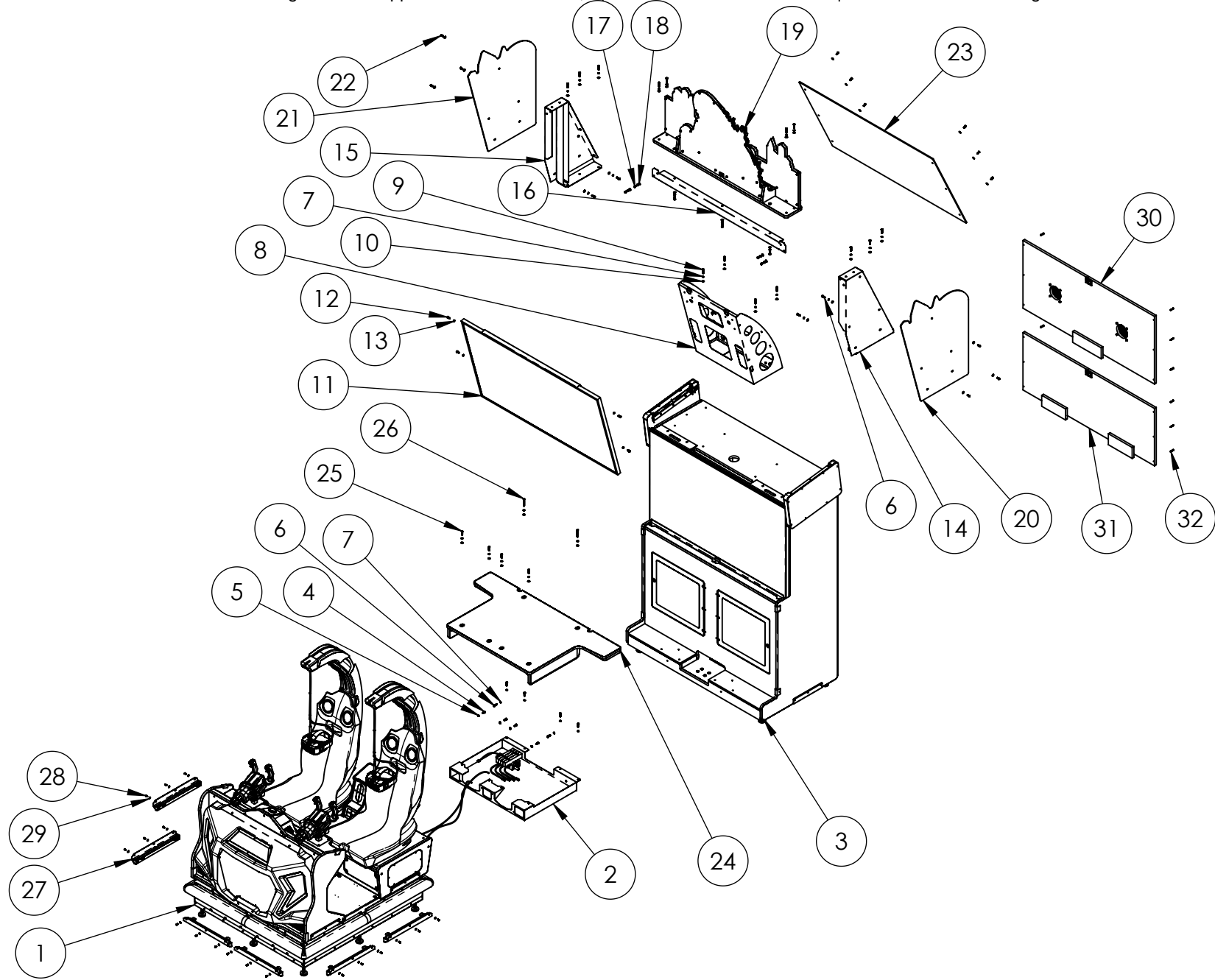

GODZILLA KAIJU WARS VR Game Assembly



ITEM NO.	PART NUMBER	DESCRIPTION	QTY.
1	GVR-Motion_Platform_Sub-Assy	Motion Platform Sub-Assembly	1
2	GVR-Spacer_Bracket_Sub-Assy	Spacer Bracket Sub-Assembly	1
3	GVR-Monitor_Cab_Sub-Assy	Monitor Cabinet Sub-Assembly	1
4	McMaster-Carr - 92865A540	Medium-Strength Grade 5 Steel Hex Head Screw, Zinc-Plated, 1/4"-20 Thread Size, 3/4" Long	4
5	McMaster-Carr - 91114A029	Zinc-Plated Steel External-Tooth Lock Washer for 1/4" Screw Size, 0.256" ID, 0.51" OD	4
6	McMaster-Carr - 92620A542	Zinc Yellow-Chromate Plated Hex Head Screw, Grade 8 Steel, 1/4"-20 Thread Size, 1" Long	13
7	McMaster-Carr - 91102A750	Zinc-Plated Steel Split Lock Washer for 1/4" Screw Size, 0.26" ID, 0.487" OD	31
8	600-02888-01	Upper Monitor Mounting Bracket	1
9	McMaster-Carr - 92865A544	Medium-Strength Grade 5 Steel Hex Head Screw, Zinc-Plated, 1/4"-20 Thread Size, 1-1/4" Long, Fully Threaded	14
10	McMaster-Carr - 90126A029	Zinc-Plated Steel SAE Washer for 1/4" Screw Size, 0.281" ID, 0.625" OD	21
11	GVR-Upper_Monitor_Hanger_Sub-Assy	Upper Monitor Hanger Sub-Assembly	1
12	McMaster-Carr - 92965A540	Black-Oxide Grade 5 Steel Hex Head Screws, Medium-Strength, 1/4"-20 Thread Size, 3/4" Long	4
13	McMaster-Carr - 92146A621	18-8 Stainless Steel Split Lock Washer, Black Oxide, for 1/4" Screw Size, 0.260" ID, 0.487" OD	10
14	RAP-118	Right Topper Support Bracket	1
15	RAP-119	Left Topper Support Bracket	1
16	R1-1115	Topper Support Bracket	1
17	McMaster-Carr - 92865A537	Medium-Strength Grade 5 Steel Hex Head Screw, Zinc-Plated, 1/4"-20 Thread Size, 1/2" Long	4
18	McMaster-Carr - 97416A119	Black-Oxide Steel SAE Flat Washer for 1/4" Screw Size, 0.281" ID, 0.625" OD	22
19	GVR-Topper_Sub-Assy	Topper Sub-Assembly	1
20	R90-13-8	Upper Right Graphic Panel	1
21	R90-13-9	Upper Left Graphic Panel	1
22	McMaster-Carr - 96075A219	Black-Oxide Alloy Steel Tamper-Resistant Torx Rounded Head Screws, 1/4"-20 Thread Size, 3/4" Long	12
23	R90-13-161	Upper Rear Graphic Panel	1
24	GVR-Spacer_Cap_Sub-Assy	Spacer Cap Sub-Assembly	1
25	Partec - 31-TP250-03-001	Black Oxide Steel Tamper-Resistant Button Head Torx Screws, 1/4"-20 Thread Size, 1-1/4" Long	4
26	Partec - 31-TP250-03-007	Black Oxide Steel Tamper-Resistant Button Head Torx Screws, 1/4"-20 Thread Size, 2-1/2" Long	2
27	GVR-Platform-Downlighting_Sub-Assy	Platform Downlighting Sub-Assembly	6
28	McMaster-Carr - 96075A187	Alloy Steel Tamper-Resistant Button Head Torx Screws, 10-32 Thread, 1/2" Long	18
29	McMaster-Carr - 97416A115	Black-Oxide Steel SAE Washer for Number 10 Screw Size, 0.219" ID, 0.5" OD	18
30	GVR-Upper_Back_Door_Sub-Assy	Upper Back Door Sub-Assembly	1
31	GVR-Lower_Back_Door_Sub-Assy	Lower Back Door Sub-Assembly	1
32	McMaster-Carr - 90190A201	Phillips Rounded Head Screws for Sheet Metal, Zinc-Plated Steel, Number 8 Size, 1-1/4" Long	12

GODZILLA KAIJU WARS VR Game Assembly



ITEM NO.	PART NUMBER	DESCRIPTION	QTY.
1	GVR-Motion_Platform_Mech_Sub-Assy	Motion Platform Mechanism Sub-Assembly	1
2	GVR-Control_Cab_Sub-Assy	Control Cabinet Sub-Assembly	1
3	GVR-Seat_Cab_Sub-Assy	Seat Cabinet Sub-Assembly	1
4	R1-1041	Footrest Treadplate	2
5	R1-1042	Center Platform Treadplate	1

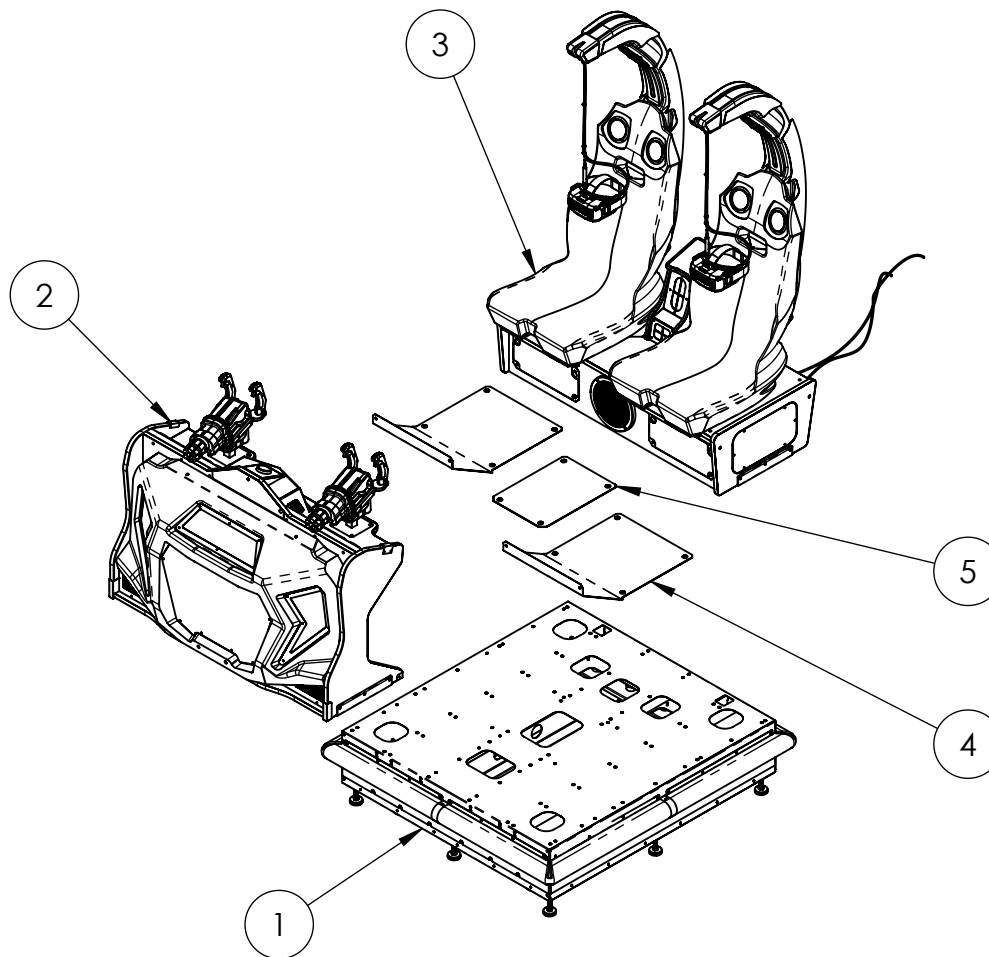

GODZILLA KAIJU WARS VR Motion Platform Sub-Assembly



ITEM NO.	PART NUMBER	DESCRIPTION	QTY.
1	GVR-Base_Platform_Sub-Assy	Base Platform Sub-Assembly	1
2	GVR-Motion_Platform_Skirt_Sub-Assy-A	Motion Skirt Sub-Assembly - A (P1 Rear & P2 Front)	2
3	GVR-Motion_Platofrm_Skirt_Sub-Assy-B	Motion Skirt Sub-Assembly - B (P1 Front & P2 Rear)	2
4	R1-1079	F/R Skirt Retainer Plate	4
5	R1-1080	Side Skirt Retainer Plate	4
6	GVR-Top_Platform_Sub-Assy	Top Platform Sub-Assembly	1

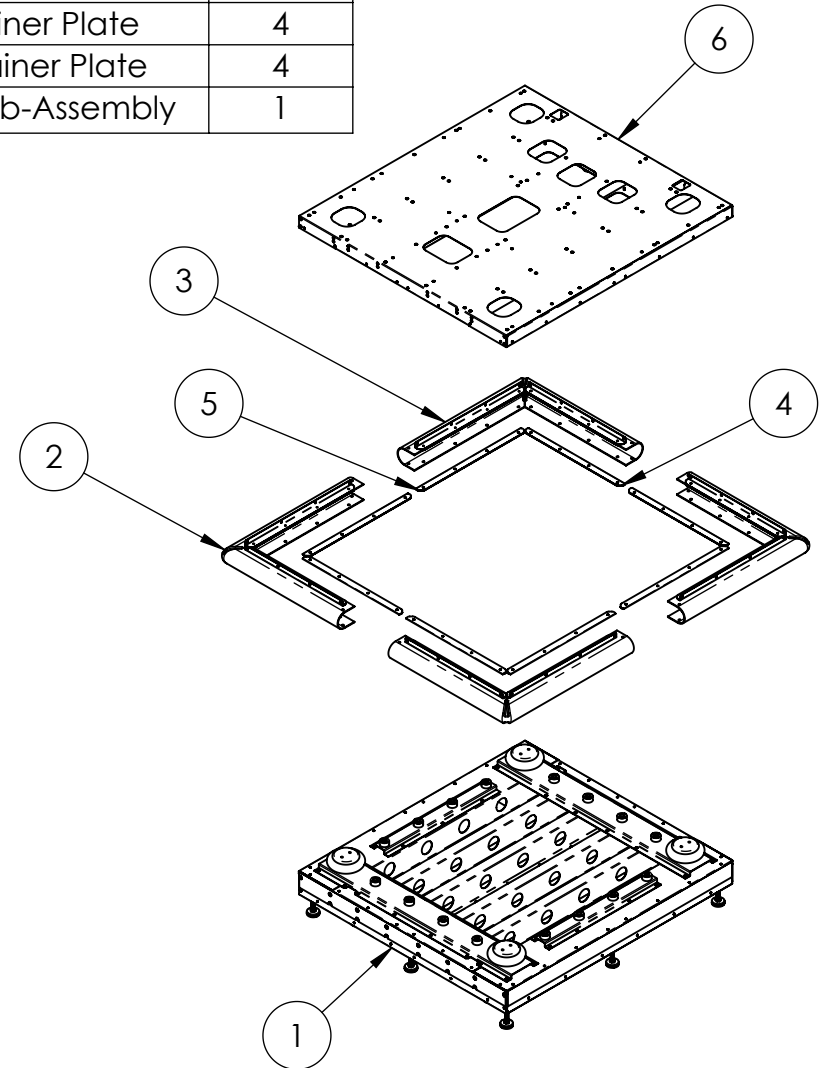

GODZILLA KAIJU WARS VR Motion Platform Mechanism Sub-Assembly



ITEM NO.	PART NUMBER	DESCRIPTION	QTY.
1	RAP-103	Base Platform Weldment	1
2	800-00087-01	JuLang Swivel Caster (2.5" Wheel)	4
3	600-01633-01	Leg Leveler Plate	7
4	Partec - 17-278	Leg Leveler #1/2-13 Thread, 3"Long, Fully Threaded (33-9505-01)	7
5	McMaster-Carr - 95462A033	Medium-Strength Steel Hex Nut, Grade 5, Zinc-Plated, 1/2"-13 Thread Size	7
6	AEH - 04-12-500	Wire Harness Clip (for 1/2" Bundle Diameter)	4
7	GVR-Rear_Air_Spring_Sub-Assy	Rear Air Spring Sub-Assembly (w/ 30" Tube)	2
8	GVR-Front_Air_Spring_Sub-Assy	Front Air Spring Sub-Assembly (w/ 72" Tube)	2
9	600-02837-01	Unthreaded Bumper, SBR Rubber, 1-1/2" OD, 3/4" High	16
10	R90-13-23	Base Platform Front Caution Decal	1
11	R90-13-24	Base Platform Side Caution Decal	2

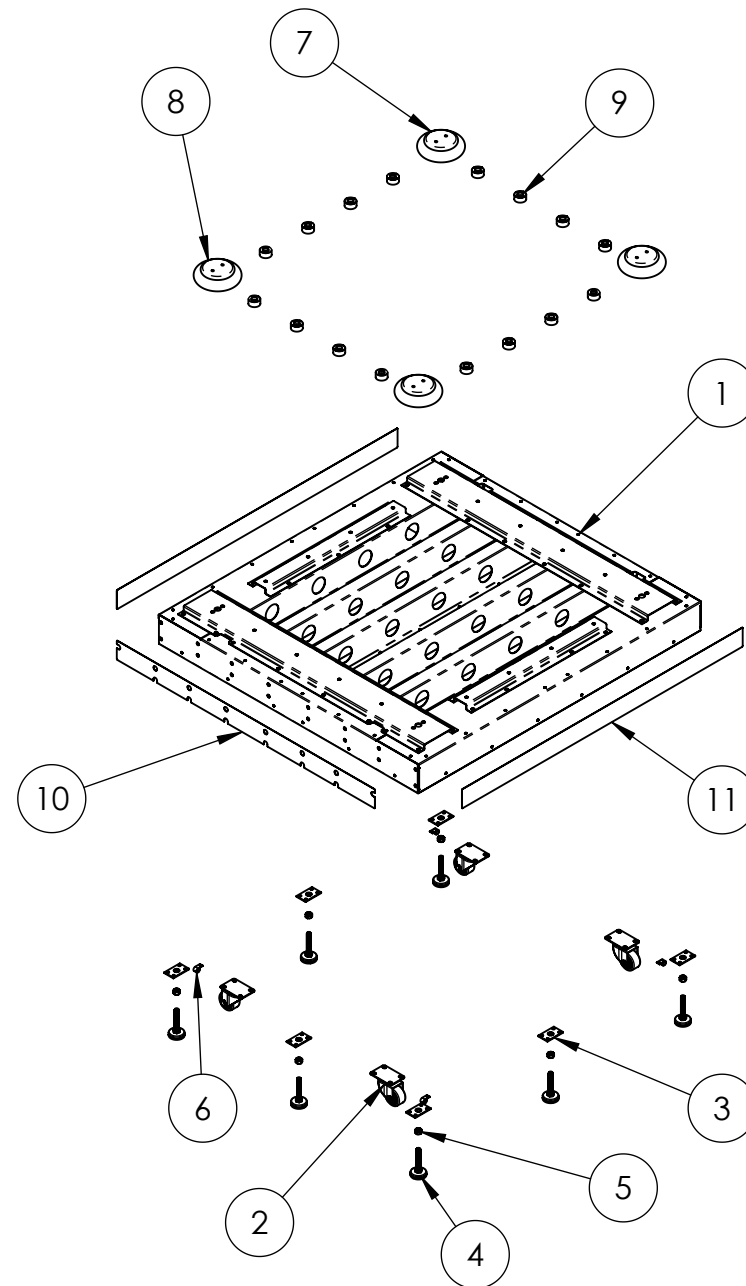

GODZILLA KAIJU WARS VR Base Platform Sub-Assembly



ITEM NO.	PART NUMBER	DESCRIPTION	QTY.
1	R7-1000	Rubber Safety Skirt	1
2	R1-1081	F/R Skirt Retainer Bracket	1
3	R1-1079	F/R Skirt Retainer Plate	1
4	R1-1082	Side Skirt Retainer Bracket	1
5	R1-1080	Side Skirt Retainer Plate	1

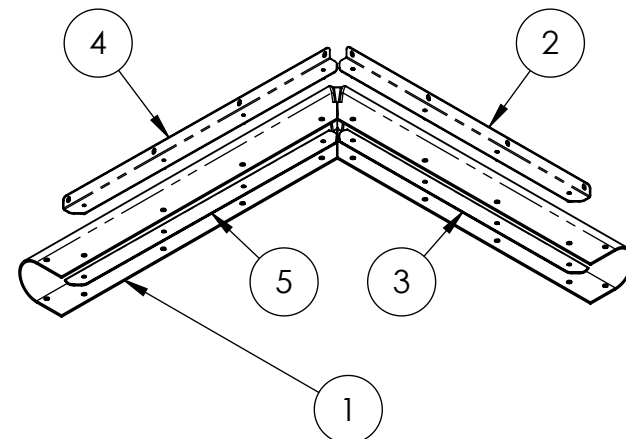

P1 FRONT AND P2 REAR
ORIENTATION "B"

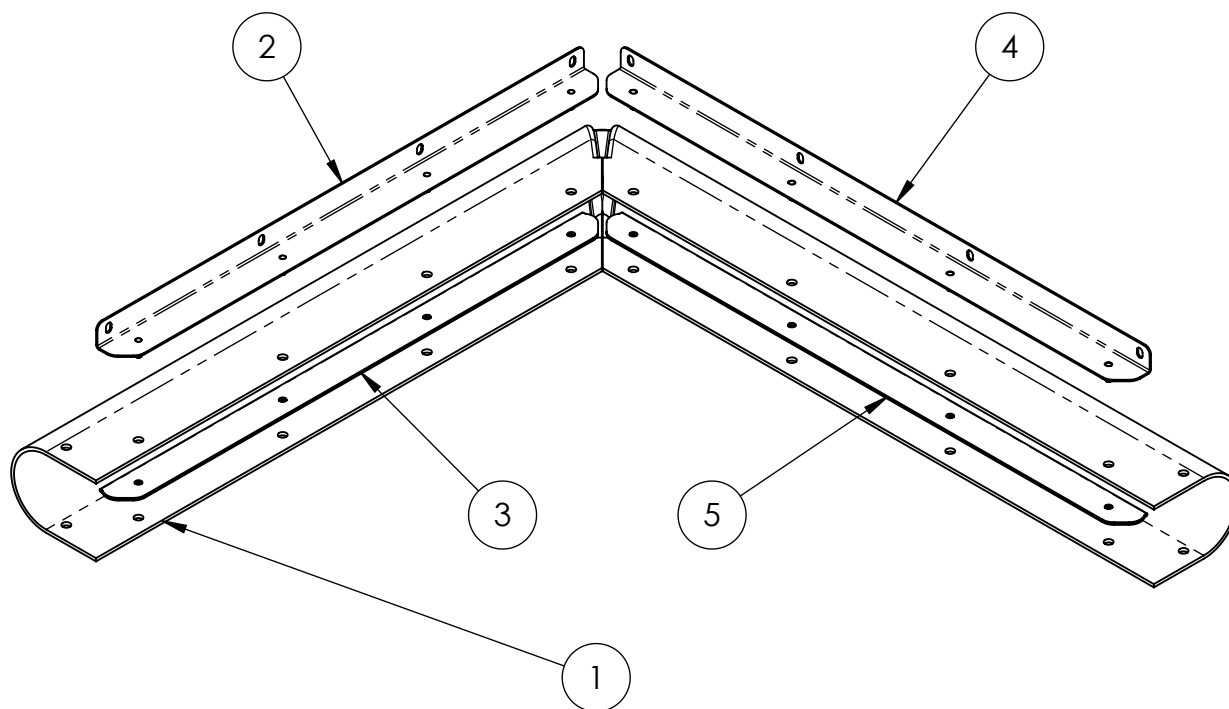

P1 REAR AND P2 FRONT
ORIENTATION "A"

GODZILLA KAIJU WARS VR Motion Skirt Sub-Assembly



ITEM NO.	PART NUMBER	DESCRIPTION	QTY.
1	RAP-104	Top Platform Weldment	1
2	600-02837-01	Unthreaded Bumper, SBR Rubber, 1-1/2" OD, 3/4" High	16

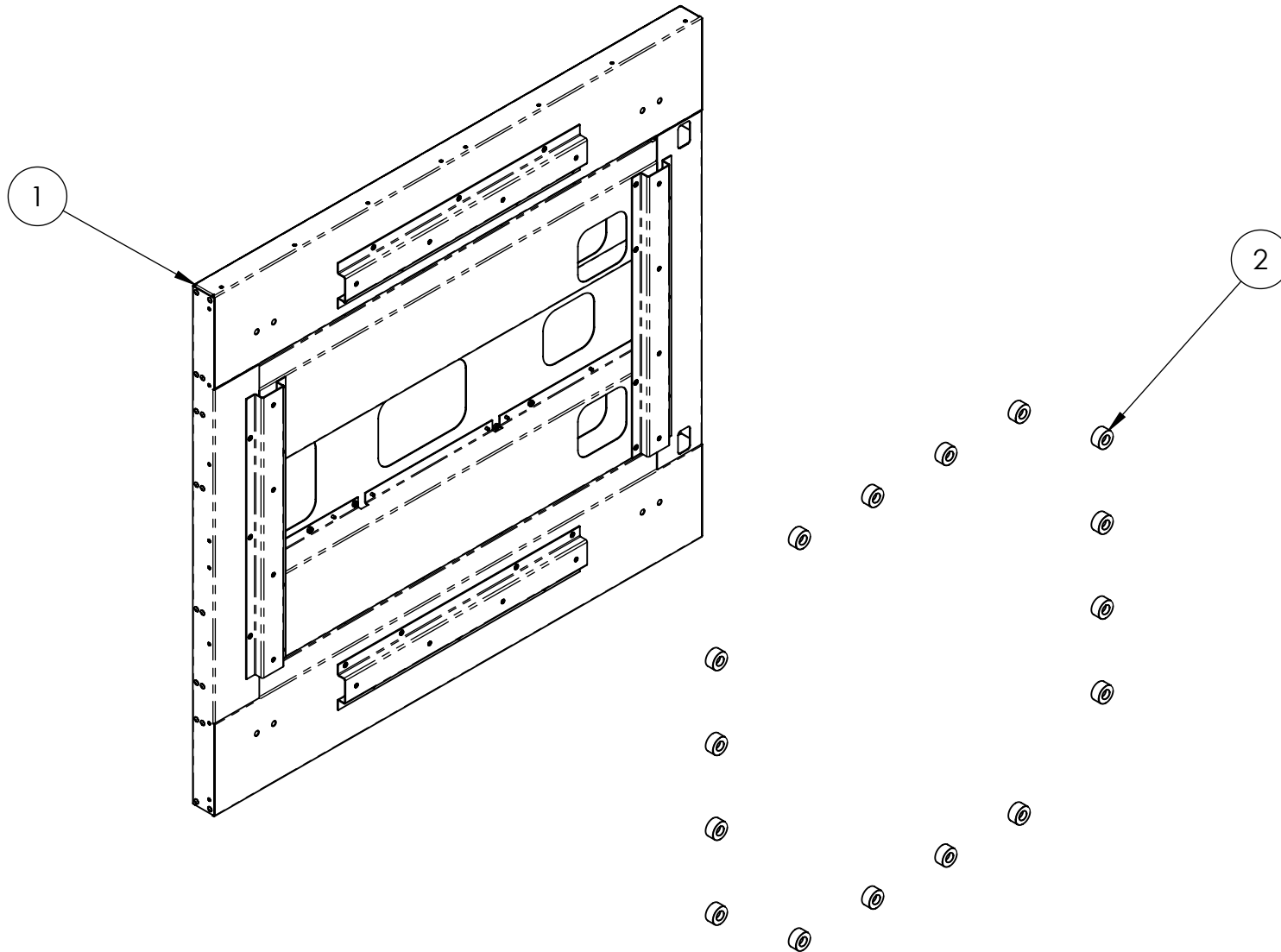

GODZILLA KAIJU WARS VR Top Platform Sub-Assembly



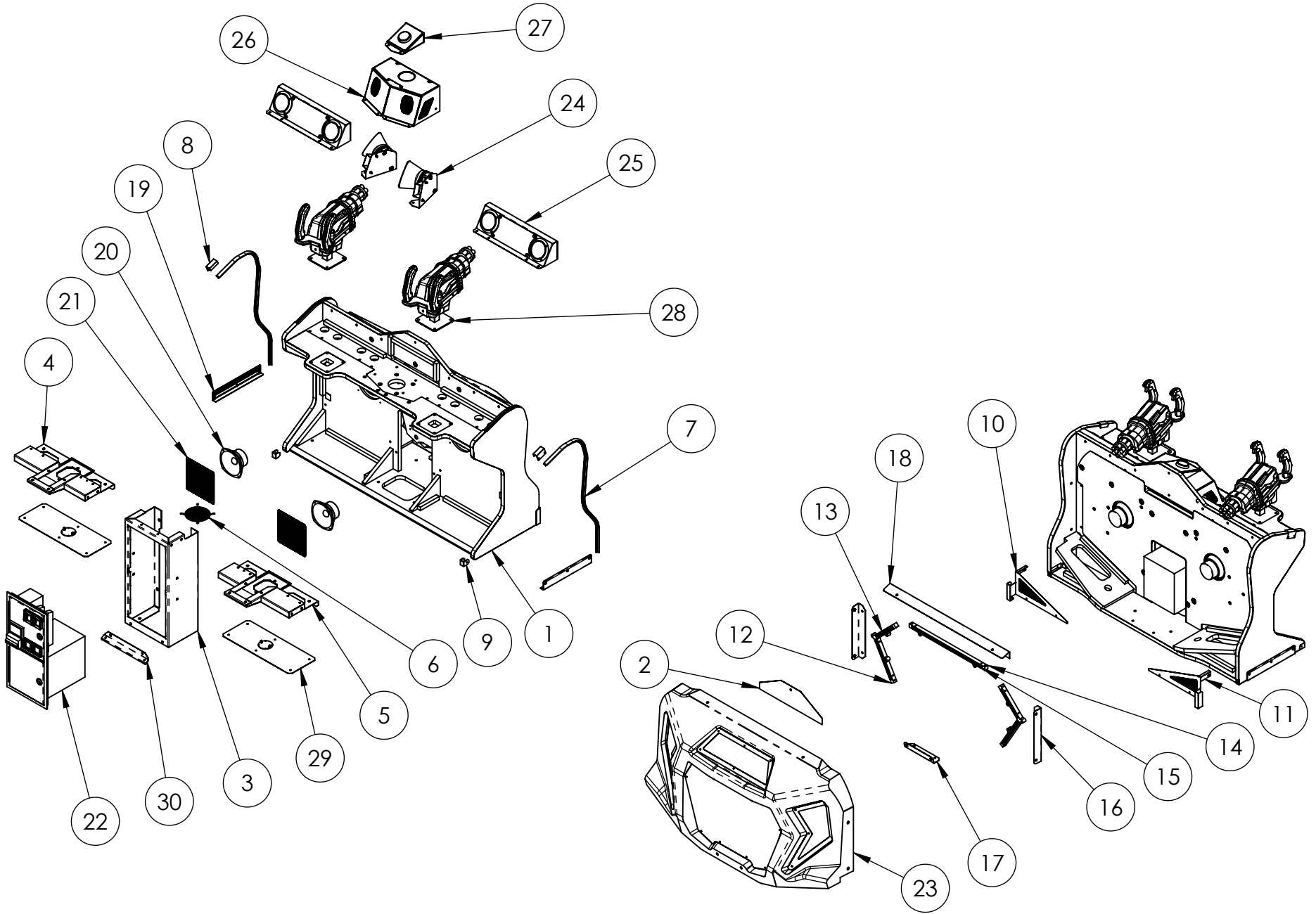

GODZILLA KAIJU WARS VR Control Cabinet Sub-Assembly



ITEM NO.	PART NUMBER	DESCRIPTION	QTY.
1	R90-23-10	Control Cabinet	1
2	R90-13-48	Upper Front Control Cab Decal	1
3	RAP-107	Coin Vault	1
4	RAP-111	P1 Gun Mount Weldment	1
5	RAP-112	P2 Gun Mount Weldment	1
6	800-00001-00	120mm Wire Fan Guard	1
7	603-00718-01 (36.75in)	LED T-Molding Extrusion - 36.75" (& CR-25: RGB Flexible LED Tape, NO FOAM, 90CM, 500-00131-01)	2
8	600-03093-01	LED Wide Bracket	2
9	R1-1070	T-Molding Clip	2
10	RAP-108	Left Corner Grill Cover	1
11	RAP-109	Right Corner Grill Cover	1
12	R90-23-23	Vacform Side LED Mount Panel	2
13	CR-37	Side Lens LED: RGB Flexible LED Tape, w/ FOAM, 20&15CM (500-00184-01)	2
14	R90-23-22	Vacform Center LED Mount Panel	1
15	CR-39	Upper Lens LED: RGB Flexible LED Tape, w/ FOAM, 45CM (500-00184-01)	1
16	R1-1052	Vacform Side Bracket	2
17	R1-1053	Vacform Bottom Bracket	1
18	600-02510-01	Vacform Upper Bracket	1
19	603-01002-01	T-Molding Molded Retaining Clip - 12" Clear	2
20	2-1-10-00-00-000	5.25" Speaker, 8 Ohm, Full Range (Goldwood)	2
21	600-01464-01	Speaker Grill	2
22	800-00005-01	Mid-Width Coin Door Assembly (Suzo-Happ)	1
23	GVR_Front_Vacform_Sub-Assy	Front Vacform Sub-Assembly	1
24	GVR-Mini_Blower_Sub-Assy	Mini Blower Sub-Assembly	2
25	GVR-Dash_Dual_Speaker_Sub-Assy	Dash Dual Speaker Sub-Assembly	2
26	GVR-Blower_Cover_Sub-Assy	Blower Cover Sub-Assembly	1
27	GVR-Center_Motion_Stop_Sub-Assy	Center Motion Stop Sub-Assembly	1
28	GVR-Gun_Mech_Sub-Assy	Full Gun Mech Sub-Assembly	2
29	GVR-Gun_Access_Plate_Sub-Assy	Gun Access Plate Sub-Assembly	2
30	R1-1090	Control Cabinet Base Edge Guard	1

GODZILLA KAIJU WARS VR Control Cabinet Sub-Assembly



ITEM NO.	PART NUMBER	DESCRIPTION	QTY.
1	R90-4-5	Vacform Front End Plastic	1
2	R4-1015	Front Vacform Upper Lens	1
3	R1-1092	Front Vacform Upper Bezel	1
4	R4-1016	Front Vacform Right Lens	1
5	R4-1017	Front Vacform Left Lens	1
6	R1-1093	Front Vacform Side Bezel	2
7	CA-4879	Logo Translite LED: White Flexible LED Tape, w/ FOAM, 40&40&40CM (500-00162-01)	1
8	R90-13-4	Vacform Logo Translite	1
9	600-02514-01	Vacform Marquee Lens PETG	1
10	CR-38	RGB Flexible LED Tape, w/ FOAM, 105CM (500-00184-01)	1

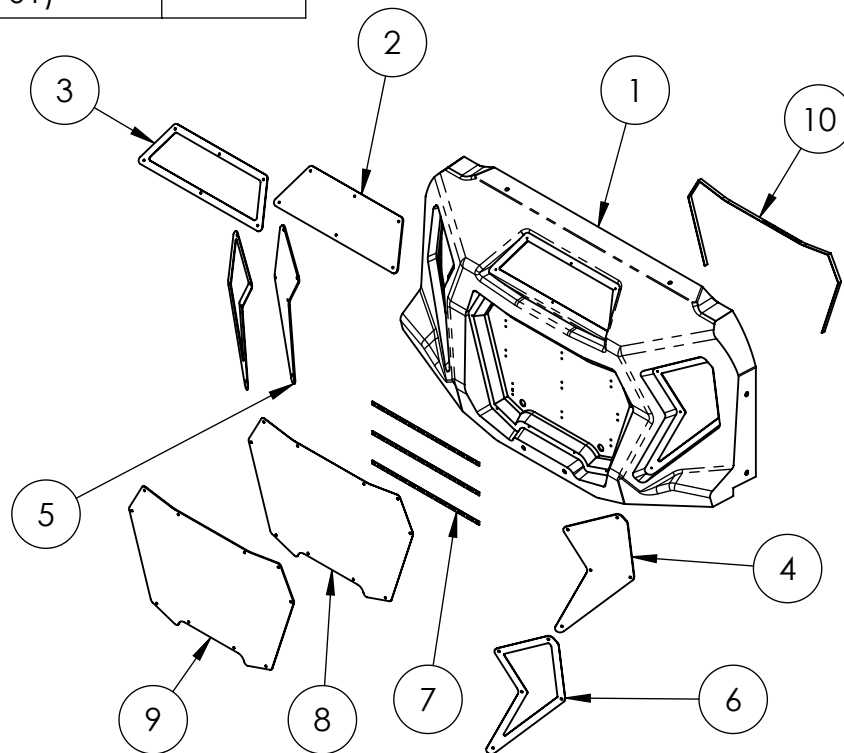

GODZILLA KAIJU WARS VR Front Vacform Sub-Assembly



ITEM NO.	PART NUMBER	DESCRIPTION	QTY.
1	R1-1008	Mini Blower Mount Bracket	1
2	CR-9	R90-10-1: San Ace Fan Blower (9BMB12P2K01)	1
3	R1-1095	Mini Blower Duct Plate	1
4	McMaster-Carr - 93075A194	Low-Strength Zinc-Plated Steel Hex Head Screws, 8-32 Thread Size, 1/2" Long	4
5	R1-1100	Mini Blower Filter Plate	1
6	R7-1002	Mini Blower Filter	1
7	Partec - 4-114-5	14.5" Cable Tie	1
8	Partec - 31-MS008-03-006	Black Oxide Steel Hex Head Screws, 8-32 Thread Size, 1-3/4" Long	2
9	McMaster-Carr - 90631A009	Low-Strength Steel Nylon-Insert Locknut, Zinc-Plated, 8-32 Thread Size	2

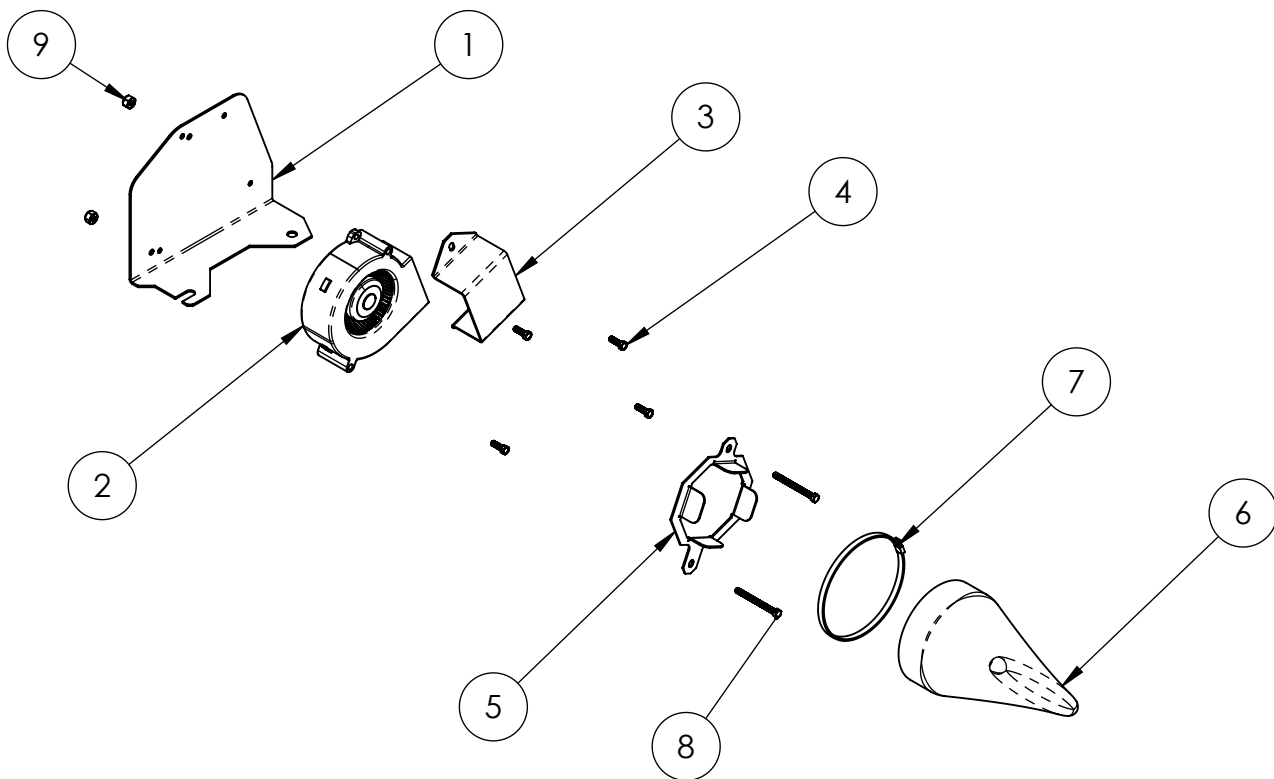

GODZILLA KAIJU WARS VR Mini Blower Sub-Assembly



ITEM NO.	PART NUMBER	DESCRIPTION	QTY.
1	R1-1089	Dual Speaker Dash Bracket	1
2	807-00010-00	3-1/2" Full Range Speaker	2
3	807-00014-00	3-1/2" Speaker Grill	2
4	McMaster-Carr - 96075A143	Alloy Steel Tamper-Resistant Button Head Torx Screws, 8-32 Thread, 3/4" Long	8
5	McMaster-Carr - 90675A009	Steel Locknut with External-Tooth Lock Washer, Zinc-Plated, 8-32 Thread Size, 11/32" Wide	8
6	CA-4834	White Flexible LED Tape, w/ FOAM, 15CM (500-00162-01)	1
7	R90-13-5	Dash Gun Graphic PETG	1
8	McMaster-Carr - 96075A139	Alloy Steel Tamper-Resistant Button Head Torx Screws, 8-32 Thread, 1/2" Long	4
9	McMaster-Carr - 97416A113	Black-Oxide Steel SAE Washer for Number 8 Screw Size, 0.188" ID, 0.438" OD	4
10	McMaster-Carr - 90133A013	Oil-Resistant Neoprene Rubber Sealing Washer for Number 10 Screw Size, 0.17" ID, 0.375" OD	4

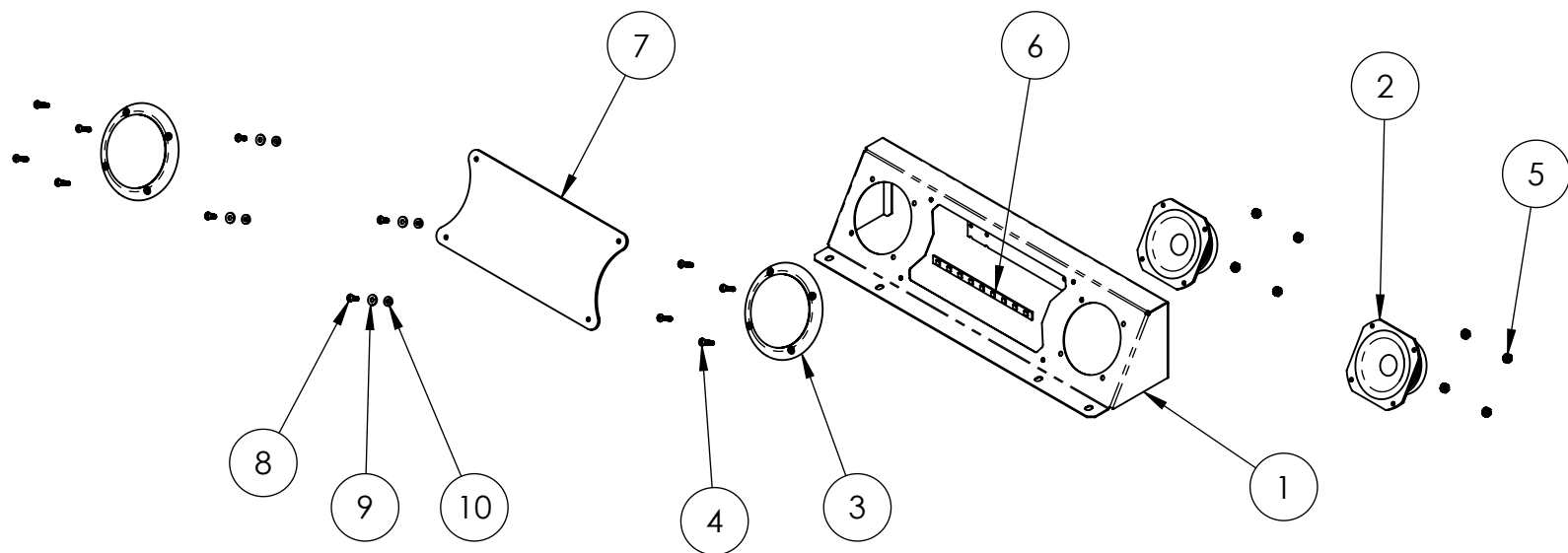

GODZILLA KAIJU WARS VR Dash Dual Speaker Sub-Assembly



ITEM NO.	PART NUMBER	DESCRIPTION	QTY.
1	RAP-100	Dual Blower Cover Bracket	1
2	R90-13-39	Blower Cover Top Decal	1
3	R90-13-40	Blower Cover P1 Decal	1
4	R90-13-41	Blower Cover P2 Decal	1

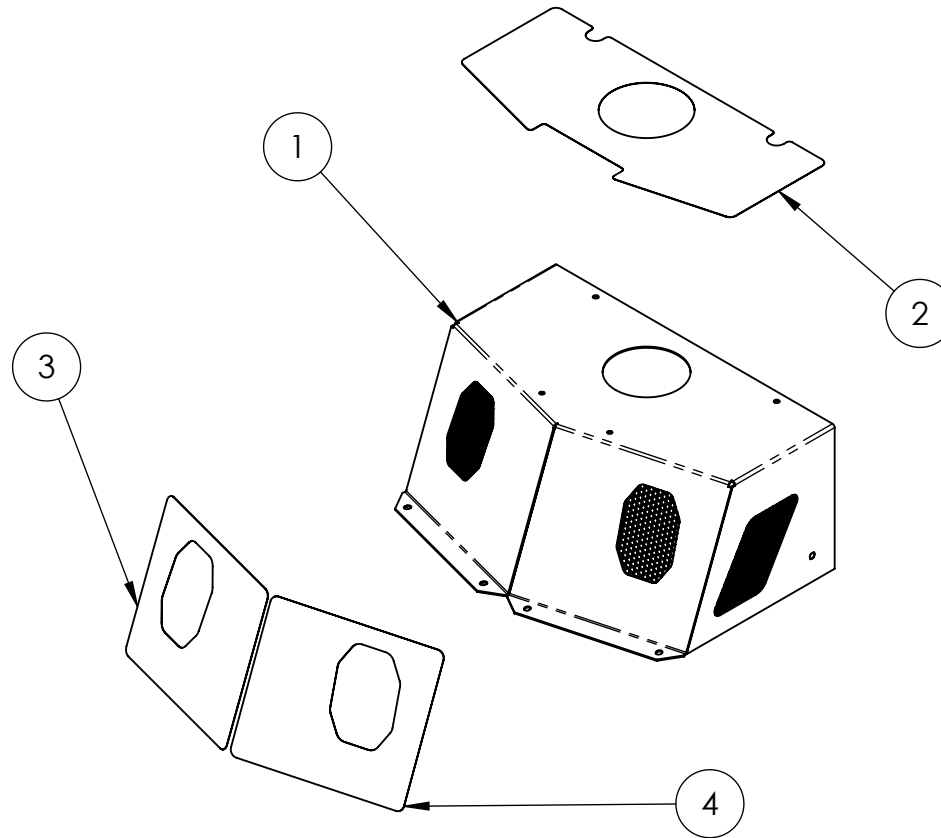

GODZILLA KAIJU WARS VR Blower Cover Sub-Assembly



ITEM NO.	PART NUMBER	DESCRIPTION	QTY.
1	R1-1038	Motion Stop Button Bracket	1
2	R90-13-38	Motion Stop Decal	1
3	702-00118-01	Large Round Yellow IPB (.187 Gold MS, 6V White LED, "MOTION STOP")	1
4	R90-13-152	Motion Stop Right Decal	1
5	R90-13-153	Motion Stop Left Decal	1

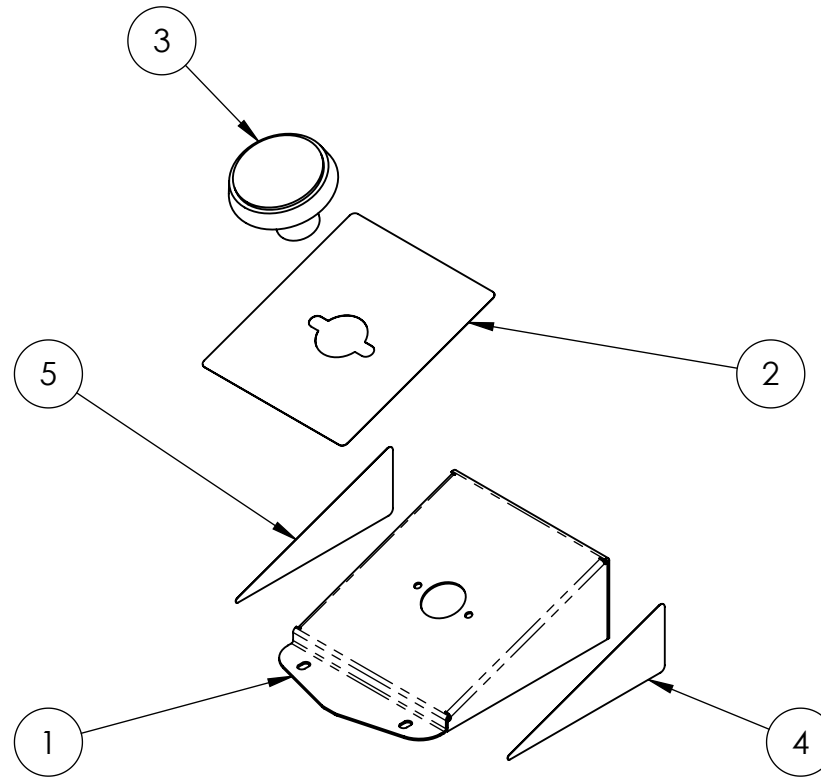

GODZILLA KAIJU WARS VR Center Motion Stop Sub-Assembly



ITEM NO.	PART NUMBER	DESCRIPTION	QTY.
1	R1-1094	Gun Mount Access Plate	1
2	603-00540-01	LED Spotlight Lens - Red Tint	1
3	McMaster-Carr - 96075A143	Alloy Steel Tamper-Resistant Button Head Torx Screws, 8-32 Thread, 3/4" Long	2
4	500-00065-01	Red LED Puck Light PCB (Black)	1
5	McMaster-Carr - 97416A113	Black-Oxide Steel SAE Washer for Number 8 Screw Size, 0.188" ID, 0.438" OD	2
6	McMaster-Carr - 90675A009	Steel Locknut with External-Tooth Lock Washer, Zinc-Plated, 8-32 Thread Size, 1 1/32" Wide	2

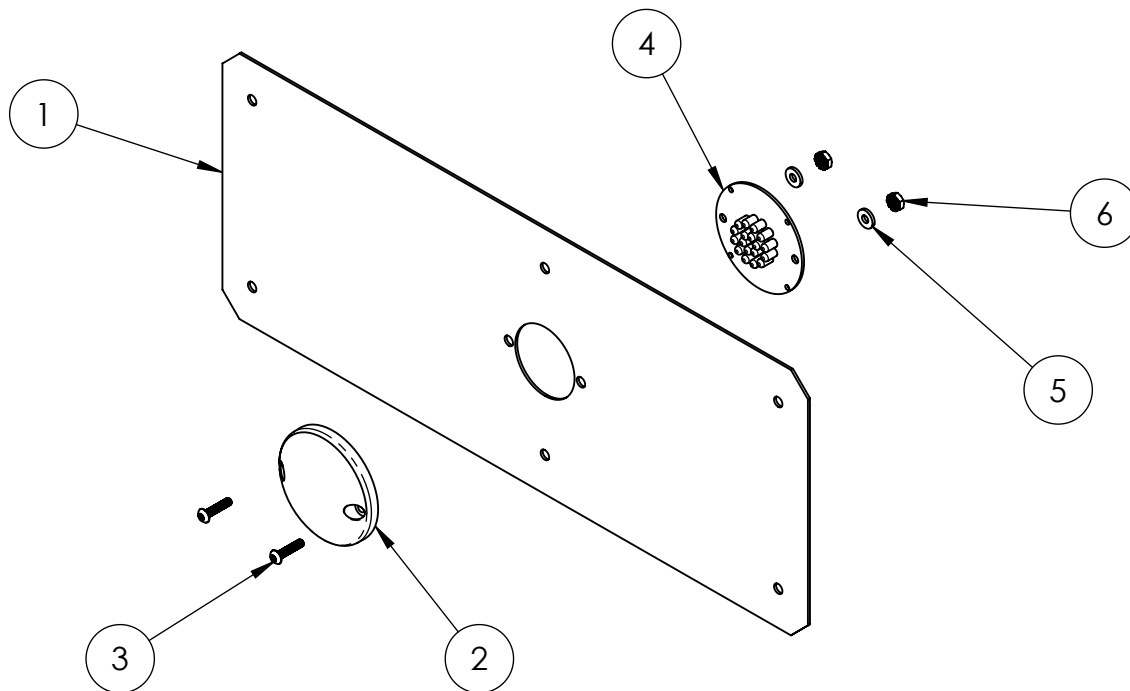

GODZILLA KAIJU WARS VR Gun Access Plate Sub-Assembly



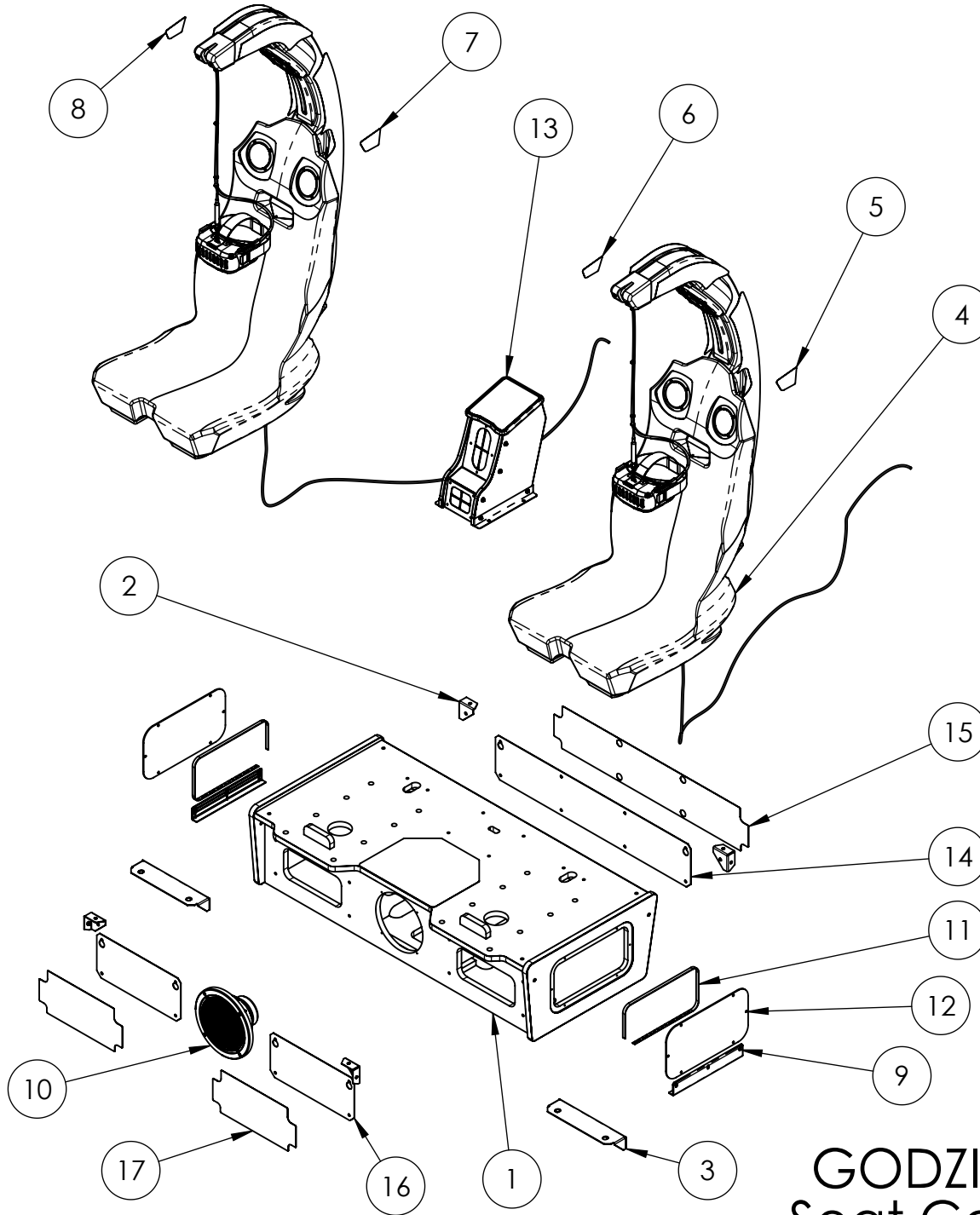

GODZILLA KAIJU WARS VR Seat Cabinet Sub-Assembly



ITEM NO.	PART NUMBER	DESCRIPTION	QTY.
1	R90-23-9	Seat Cabinet	1
2	R1-1099	Seat Panel Corner Brace	4
3	R1-1098	Front Seat Mount Bracket	2
4	GVR-Seat_Sub-Assy	Seat Sub-Assembly	2
5	R90-13-44	P1 Right Rack Cap Decal	1
6	R90-13-45	P1 Left Rack Cap Decal	1
7	R90-13-46	P2 Right Rack Cap Decal	1
8	R90-13-47	P2 Left Rack Cap Decal	1
9	603-01002-01	T-Molding Molded Retaining Clip - 12" Clear	2
10	GVR-Woofer_Sub-Assy	Woofer Sub-Assembly	1
11	CA-4456	White Flexible LED Tape, w/ FOAM, 85CM (500-00162-01)	2
12	R90-13-14	Seat VR Graphic PETG	2
13	GVR-Seat_Center_Mask_Holder_Sub-Assy	Seat Center Mask Holder Sub-Assembly	1
14	R1-1091	Seat Cabinet Rear Access Plate	1
15	R90-13-19	Rear Seat Access Plate Decal	1
16	R1-1047	Seat Cabinet Front Access Plate	2
17	R90-13-20	Front Seat Access Plate Decal	2

GODZILLA KAIJU WARS VR
Seat Cabinet Sub-Assembly



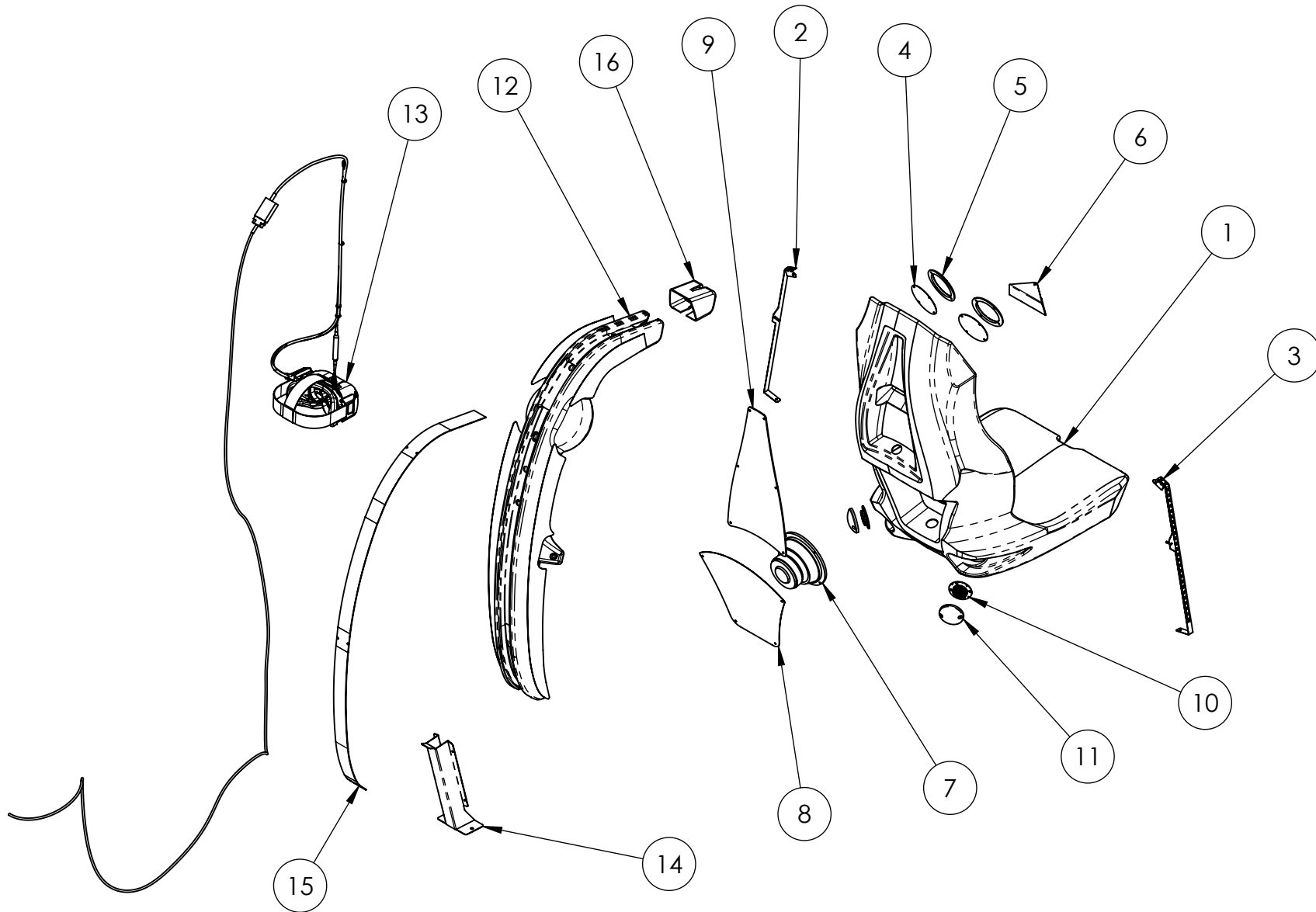

GODZILLA KAIJU WARS VR Seat Sub-Assembly



ITEM NO.	PART NUMBER	DESCRIPTION	QTY.
1	R90-4-1	Rotomolded Seat (Flag Blue)	1
2	GVR-Inner_Seat_LED_Sub-Assy-L	Left Inner Seat LED Sub-Assembly	1
3	GVR-Inner_Seat_LED_Sub-Assy-R	Right Inner Seat LED Sub-Assembly	1
4	600-00105-01	Seat Headrest Speaker Grill	2
5	807-00014-00	3-1/2" Speaker Grill	2
6	600-03084-01	Seat Blockout Plate	1
7	807-00003-00	6.5" Woofer, 4 Ohm (Goldwood)	1
8	600-00106-01	Woofer Grill	1
9	R4-1007	Seatback Cover ABS Haircell	1
10	500-00204-01	Red LED Super Puck Light PCB (Black)	2
11	603-00540-01	LED Spotlight Lens - Red Tint	2
12	GVR-Headset_Rack_Sub-Assy	Headset Rack Sub-Assembly	1
13	GVR-DPVR_E4_Headset_Sub-Assy	DPVR E4 Headset Sub-Assembly	1
14	R1-1096	Cable Cover Bracket	1
15	R4-1012	Upper Cable Cover Strip	1
16	R90-4-13	Headset Rack End Cap	1

GODZILLA KAIJU WARS VR
Seat Sub-Assembly



ITEM NO.	PART NUMBER	DESCRIPTION	QTY.
1	600-03057-01	Inner Seat LED Mounting Bracket L	1
2	CR-27	Blue Flexible LED Tape, w/ FOAM, 45CM (500-00189-01)	1

ITEM NO.	PART NUMBER	DESCRIPTION	QTY.
2	CR-27	Blue Flexible LED Tape, w/ FOAM, 45CM (500-00189-01)	1
3	600-03058-01	Inner Seat LED Mounting Bracket R	1

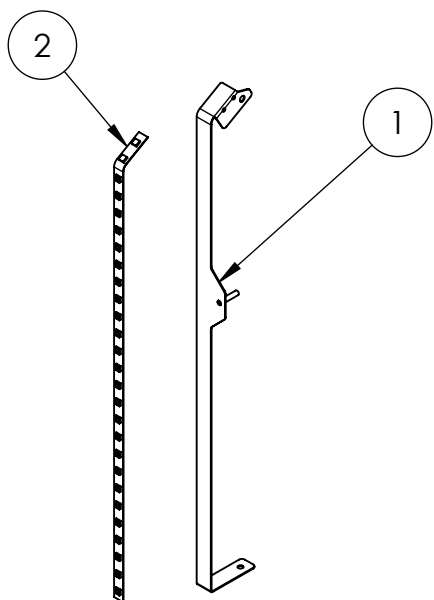

GODZILLA KAIJU WARS VR
Left Inner Seat LED Sub-Assembly

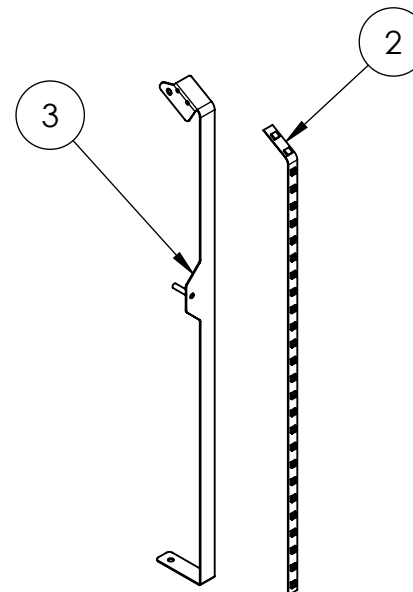

GODZILLA KAIJU WARS VR
Right Inner Seat LED Sub-Assembly

ITEM NO.	PART NUMBER	DESCRIPTION	QTY.
1	R90-4-12	Rotomolded Headset Rack	1
2	R90-13-147	Headpost Upper Right Decal	1
3	R90-13-148	Headpost Upper Left Decal	1
4	R90-13-155	Headpost Lower Right Decal	1
5	R90-13-156	Headpost Lower Left Decal	1
6	GVR-Upper_HS_Edgeglow_Sub-Assy	Upper Headset Edgeglow Sub-Assembly	1
7	GVR-Lower_HS_Edgeglow_Sub-Assy	Lower Headset Edgeglow Sub-Assembly	1
8	2-1-10-00-00-000	5.25" Speaker, 8 Ohm, Full Range (Goldwood)	1
9	R1-1075	Headset Post Speaker Screen	1
10	CA-4757	Encased RGB LED Tape, NO FOAM, 55CM (500-00245-01)	1
11	603-00890-01	IM Speaker Cover (Plated)	1

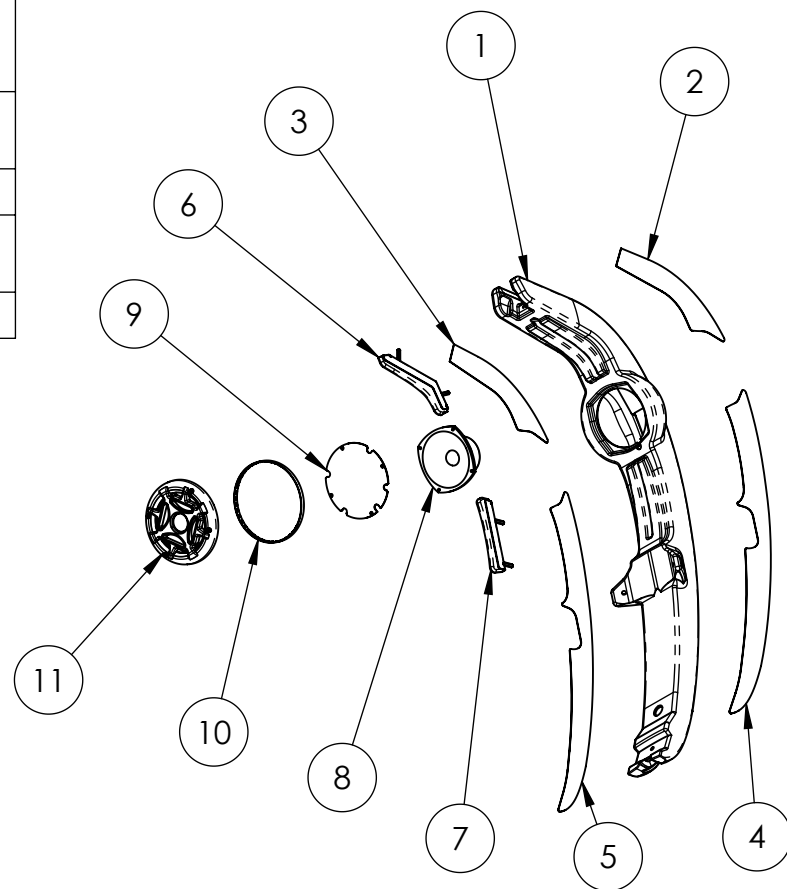

GODZILLA KAIJU WARS VR Headset Rack Sub-Assembly



ITEM NO.	PART NUMBER	DESCRIPTION	QTY.
1	R1-1076	Rack Acrylic Upper Bracket	1
2	CA-5195	RGB Flexible LED Tape, w/ FOAM, 20CM (500-00184-01)	1
3	R4-1013	Rack Upper Acrylic	1
4	McMaster-Carr - 98002A411	Steel Binding Barrels, 8-32 Thread Size, 1/4" Long	2
5	McMaster-Carr - 91780A201	Female Threaded Hex Standoff, Aluminum, 1/4" Hex, 1-1/4" Long, 8-32 Thread	2

ITEM NO.	PART NUMBER	DESCRIPTION	QTY.
4	McMaster-Carr - 98002A411	Steel Binding Barrels, 8-32 Thread Size, 1/4" Long	2
5	McMaster-Carr - 91780A201	Female Threaded Hex Standoff, Aluminum, 1/4" Hex, 1-1/4" Long, 8-32 Thread	2
6	R4-1014	Rack Lower Acrylic	1
7	CA-5194	RGB Flexible LED Tape, w/ FOAM, 15CM (500-00184-01)	1
8	R1-1077	Rack Acrylic Lower Bracket	1

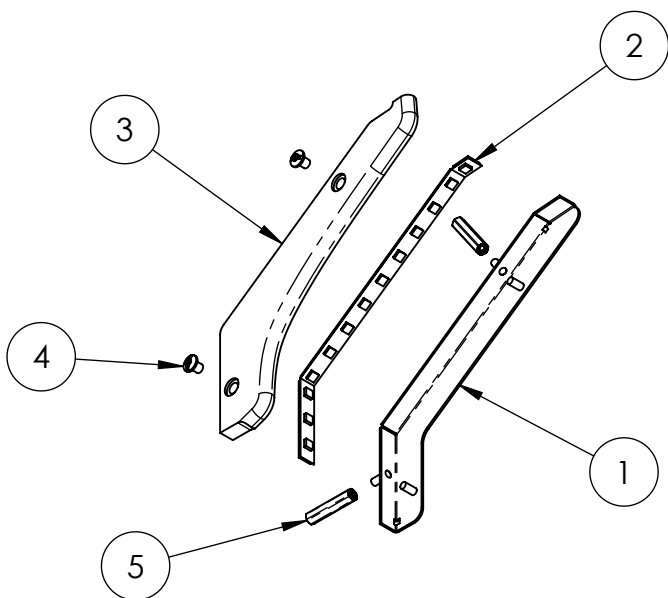

GODZILLA KAIJU WARS VR
Upper Headset Edgeglow Sub-Assembly

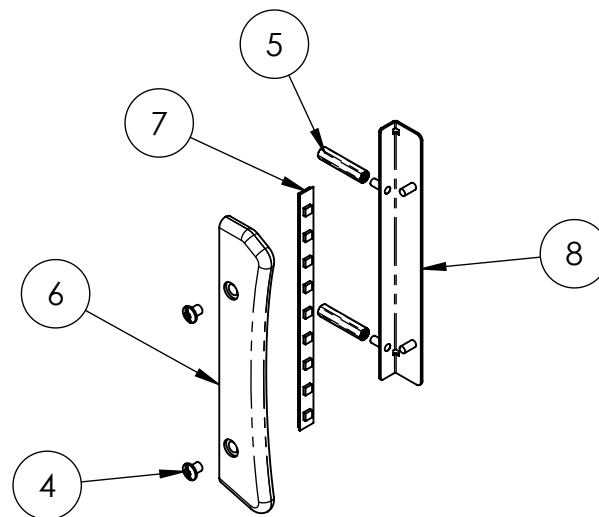

GODZILLA KAIJU WARS VR
Lower Headset Edgeglow Sub-Assembly

ITEM NO.	PART NUMBER	DESCRIPTION	QTY.
1	603-00961-01	IM 8" Woofer Ring	1
2	2-1-18-00-00-000	8" Woofer, 4 Ohm (Goldwood)	1
3	Partec - 31-CB008-03-003	Black Oxide Steel Square-Neck Carriage Bolt, 8-32 Thread Size, 1-1/4" Long	4
4	McMaster-Carr - 90675A009	Steel Locknut with External-Tooth Lock Washer, Zinc-Plated, 8-32 Thread Size, 11/32" Wide	4

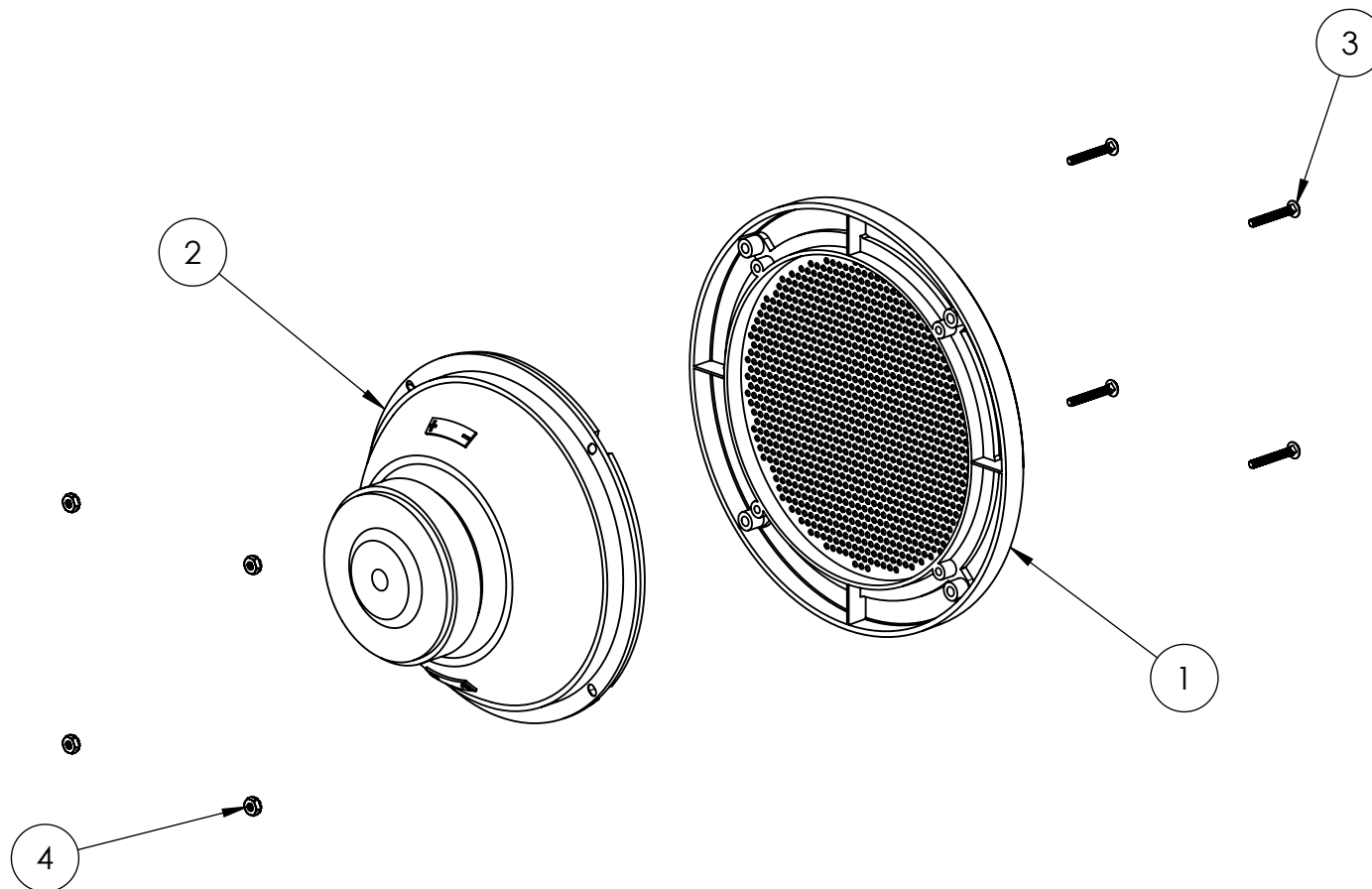

GODZILLA KAIJU WARS VR Woofer Sub-Assembly



ITEM NO.	PART NUMBER	DESCRIPTION	QTY.
1	R90-23-24	Mask Holder Wood Assembly	1
2	AEH - 04-12-500	Wire Harness Clip (for 1/2" Bundle Diameter)	3
3	McMaster-Carr - 90054A196	Flanged Hex Head Screws for Sheet Metal, Zinc-Plated Steel, Number 8 Size, 5/8" Long	3
4	R4-1020	Mask Holder Top Acrylic	1
5	CR-36	RGB Flexible LED Tape, w/ FOAM, 25CM (500-00184-01)	1
6	R1-1104	Mask Holder Top Plate	1
7	R90-13-146	Mask Holder Top Decal	1
8	McMaster-Carr - 97416A115	Black-Oxide Steel SAE Washer for Number 10 Screw Size, 0.219" ID, 0.5" OD	12
9	McMaster-Carr - 90631A411	Low-Strength Steel Nylon-Insert Locknut, Zinc-Plated, 10-32 Thread Size, 3/8" Wide, 15/64" High	2
10	R1-1105	Mask Holder Ramp Panel	1
11	McMaster-Carr - 90935A194	Phillips Rounded Head Screws for Sheet Metal, Black-Oxide Steel, Number 8 Size, 1/2" Long	4
12	GVR-Mask_Holder_Bracket_Sub-Assy	Mask Holder Bracket Sub-Assembly	1
13	R1-1106	Mask Holder Mounting Bracket	2
14	McMaster-Carr - 96075A187	Alloy Steel Tamper-Resistant Button Head Torx Screws, 10-32 Thread, 1/2" Long	2
15	McMaster-Carr - 96075A195	Alloy Steel Tamper-Resistant Button Head Torx Screws, 10-32 Thread, 1" Long	8
16	McMaster-Carr - 92146A619	18-8 Stainless Steel Split Lock Washer, Black Oxide, for Number 10 Screw Size, 0.200" ID, 0.334" OD	10

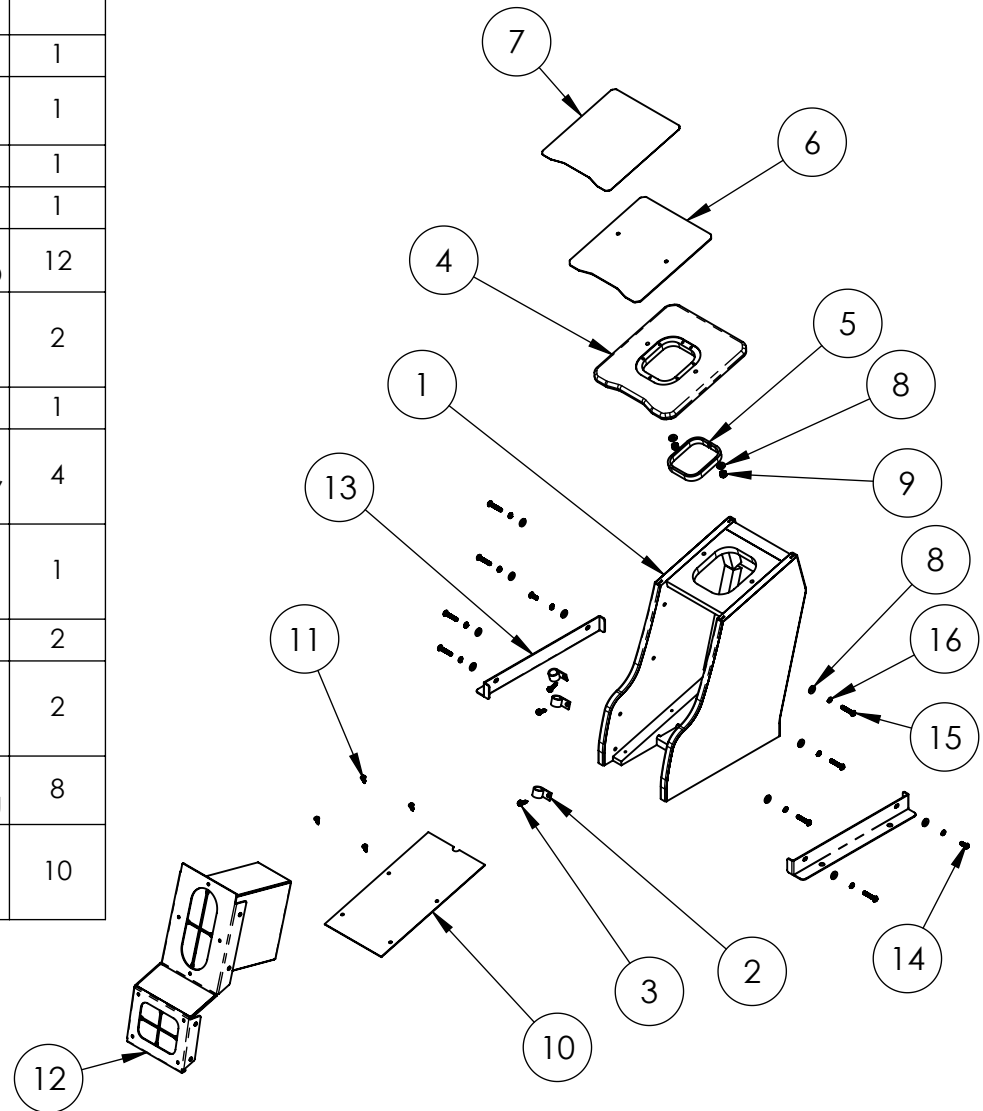

GODZILLA KAIJU WARS VR Seat Center Mask Holder Sub-Assembly



ITEM NO.	PART NUMBER	DESCRIPTION	QTY.
1	R1-1101	Mask Holder Main Cover Plate	1
2	R7-1006	Eye Mask Boot	1
3	R1-1102	Mask Holder Inner Housing Bracket	1
4	R7-1007	Handy Wipe Boot	1
5	R1-1103	Mask Holder Handy Wipe Boot Frame	1
6	McMaster-Carr - 90633A009	Low-Strength Steel Thin Nylon-Insert Locknut, Zinc-Plated, 8-32 Thread Size	8
7	R90-13-150	Mask Holder Mid Decal	1

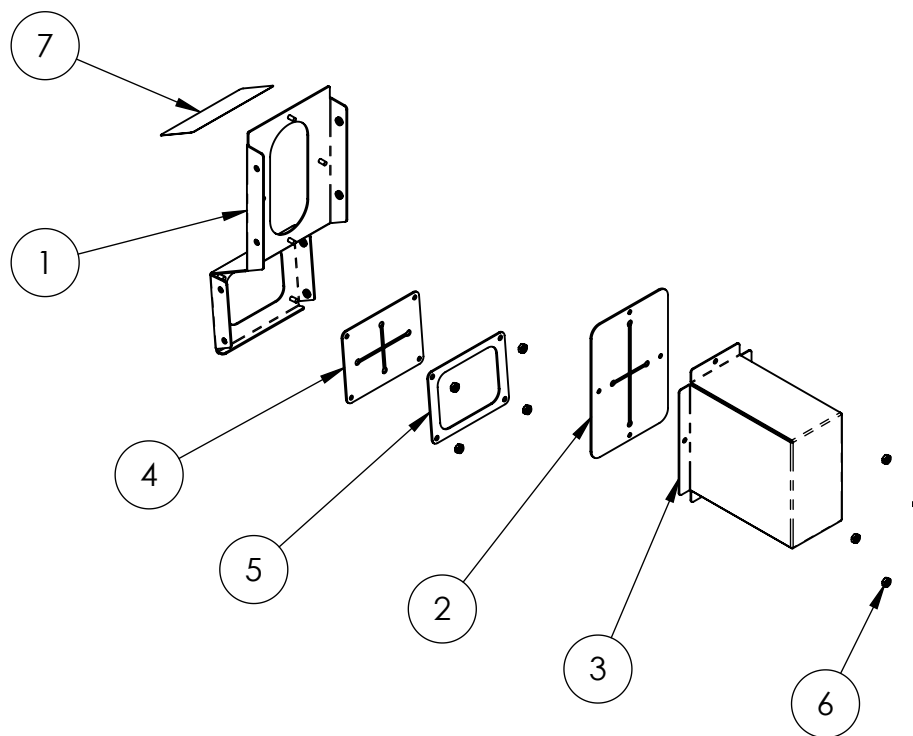

GODZILLA KAIJU WARS VR

Mask Holder Bracket Sub-Assembly



ITEM NO.	PART NUMBER	DESCRIPTION	QTY.
1	R1-1063	Spacer Base Bracket	1
2	GVR-Manifold_Sub-Assy	Manifold Sub-Assembly	1
3	McMaster-Carr - 92224A207	Black Oxide Steel Pan Head Phillips Screw, 10-32 Thread Size, 2" Long	4

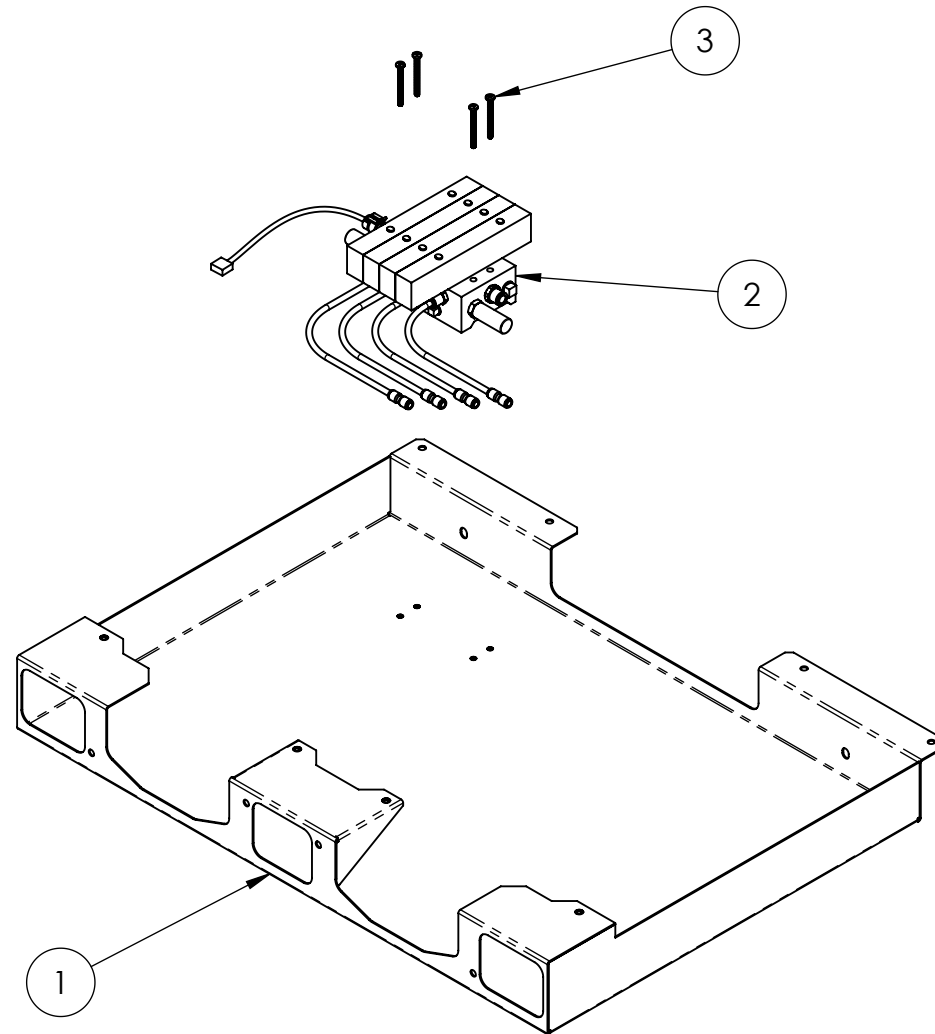

GODZILLA KAIJU WARS VR Spacer Bracket Sub-Assembly



ITEM NO.	PART NUMBER	DESCRIPTION	QTY.
1	CA-4903	604-00045-01: CKD-M4KB330-08N-4-DC12V - 4 Station Manifold	1
2	17-330	Push-to-Connect Tube Fitting for Air, Straight Adapter for 1/4" Tube OD x 1/4 NPT Male	4
3	McMaster-Carr - 5648K69 (12in)	Blue Firm Polyurethane Tubing for Air and Water, 5/32" ID, 1/4" OD - 12"	4
4	17-333-1	Fitting Push-to-Connect 1/4-1/4 Female	4
5	17-330-1	Push-to-Connect Tube Fitting for Air, Straight Adapter, for 3/8" Tube OD x 3/8 NPT Male	1
6	17-340	High-Noise Reducing Mufflers, Plastic, 3/8 NPT Male, 177 scfm, 2-5/16" High	2
7	17-332	Plug, 1/4 Pipe Size	4
8	17-332-1	Plug, 3/8 Pipe Size	2
9	17-334	Bushing Reducer, 3/8" Male x 1/4" Female	1
10	500-00195-01	Pressure Sensor	1

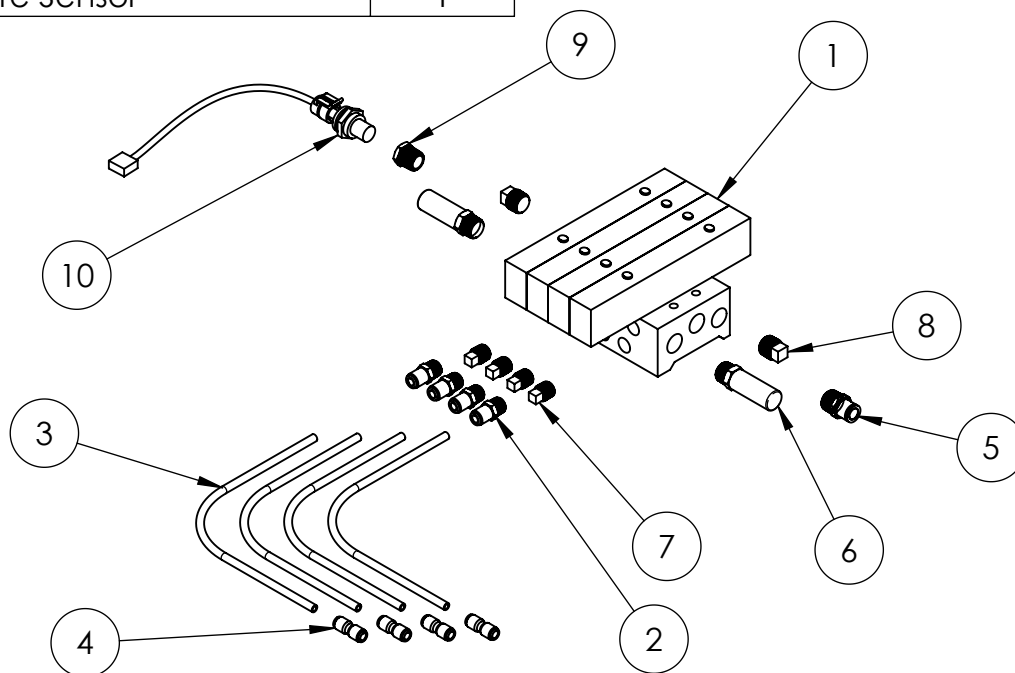

GODZILLA KAIJU WARS VR Manifold Sub-Assembly



NOTE FOR PARTS 11 & 12 & 13:
- MONITORS CHANGE
THROUGHOUT PRODUCTION
- ALL SHIPPED VERSIONS
INDICATED ON NEXT PAGE
- NOTE VOLTAGE SPECIFICATIONS

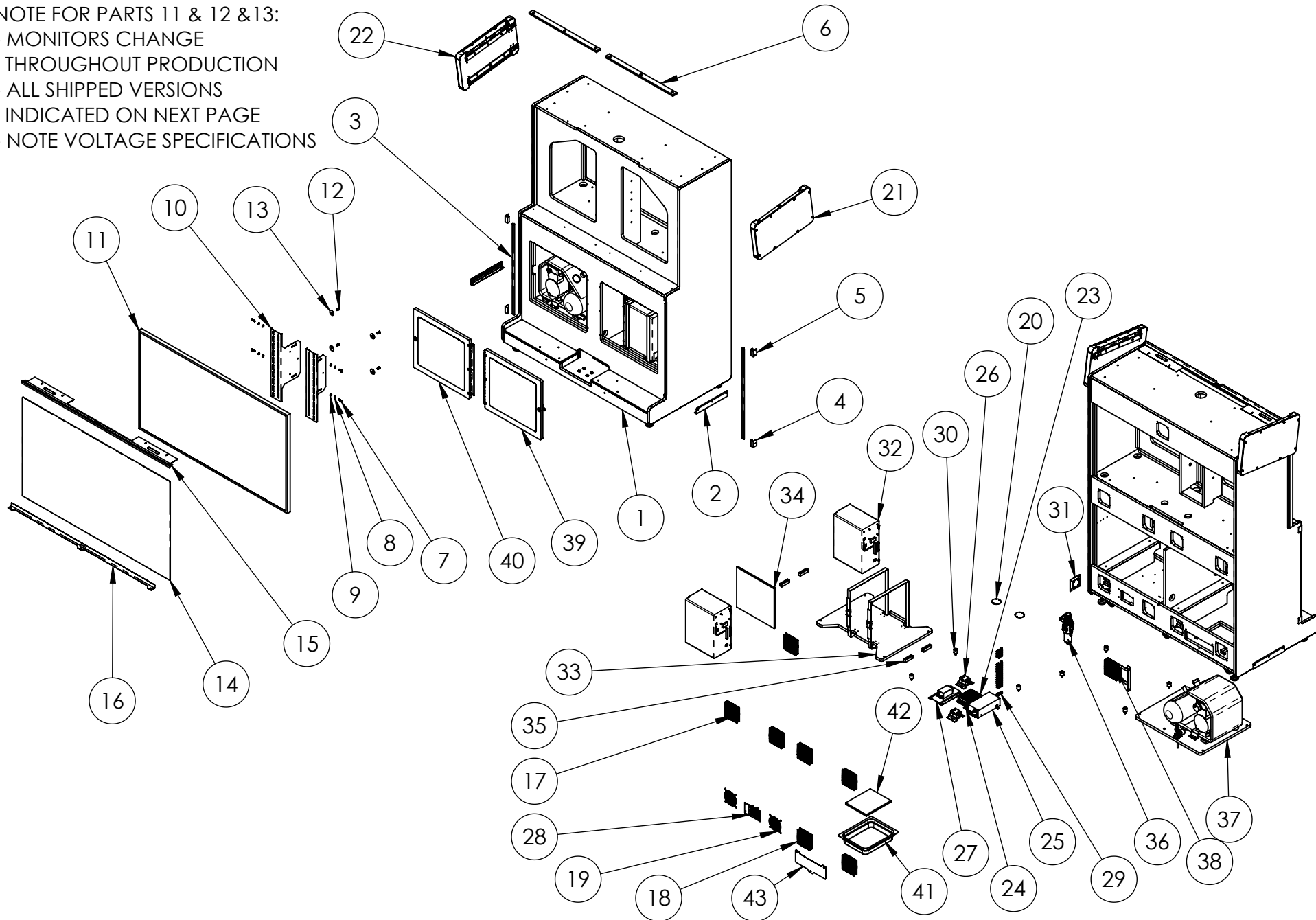

GODZILLA KAIJU WARS VR Monitor Cabinet Sub-Assembly



ITEM NO.	PART NUMBER	DESCRIPTION	QTY.
1	R90-23-1	Lower Monitor Cabinet	1
2	603-01002-01	T-Molding Molded Retaining Clip - 12" Clear	2
3	603-00718-01 (30in)	LED T-Molding Extrusion - 30" (& CA-4374: RGB Flexible LED Tape, NO FOAM, 70CM, 500-00131-01)	2
4	600-02915-01	LED Extrusion Wide Bracket	2
5	600-03093-01	LED Wide Bracket	2
6	R90-23-33	Monitor Cleat	2
7	McMaster-Carr - 92620A542	Zinc Yellow-Chromate Plated Hex Head Screw, Grade 8 Steel, 1/4"-20 Thread Size, 1" Long	4
8	McMaster-Carr - 91102A750	Zinc-Plated Steel Split Lock Washer for 1/4" Screw Size, 0.26" ID, 0.487" OD	4
9	McMaster-Carr - 90126A029	Zinc-Plated Steel SAE Washer for 1/4" Screw Size, 0.281" ID, 0.625" OD	4
10	R1-1135	Lower Monitor Mount Bracket	2
ITEMS 11-13 FOR SAMSUNG QB65C DUAL VOLTAGE MONITOR (120V & 230V) - ALTERNATIVES LISTED AT END			
11	809-00016-01 (QB65C)	Samsung QB65C Display (DUAL VOLTAGE: 120V AND 230V)	1
12	McMaster-Carr - 91280A526	Medium-Strength Class 8.8 Steel Hex Head Screw, Zinc-Plated, M8 x 1.25 mm Thread, 16 mm Long	4
13	McMaster-Carr - 90377A165	Black-Oxide 18-8 Stainless Steel Washer, Oversized, 5/16" Screw Size, 0.344" ID, 1.5" OD	4
14	R4-1025	Lower Monitor Cover Lens	1
15	RAP-113	Upper/Lower Monitor Cross Bracket	1
16	R1-1097	Lower Monitor Cross Bracket	1
17	GVR-Standard_Fan_Sub-Assy	Fan (CA-3277) and Wire Grill (800-00001-00) Assembly	3
18	GVR-Tach_&_PWM_Fan_Sub-Assy	Tach/PWM Fan (CA-4998) and Wire Grill (800-00001-00) Assembly	4
19	800-00001-00	120mm Wire Fan Guard	2
20	500-00205-01	White LED Super Puck Light PCB (Black)	2
21	GVR-Logo_Lightbox_Sub-Assy-R	Right Logo Lightbox Sub-Assembly	1
22	GVR-Logo_Lightbox_Sub-Assy-L	Left Logo Lightbox Sub-Assembly	1
23	330-00002-01	LRS-150F-24: 150W, 24V, Low Leakage Power Supply	1
24	1-1505	Power Supply Mounting Bracket	1
25	330-00003-01	HRP-600-12: 600W, 12V Dual Voltage Power Supply (Requires 2X 1-2328 - Mounting Brackets)	1
26	GVR-Solid_State_Relay_Sub-Assy	Solid State Relay Sub-Assembly	2
27	GVR-Power_Line_Filter_Sub-Assy	Power Line Filter Sub-Assembly	1
28	AC_Double_Inlet_Sub-Assy	Dual Inlet AC Power Plate Sub-Assembly	1
29	GVR-Fuseblock	Fuseblock (4X 2A SLO-BLO, 13X 5A FAST-ACT, 1X 10A FAST-ACT)	1
30	600-02972-01	Vibration-Damping Sandwich Mount with Stud and Insert, Neoprene, 1/4"-20 Thread Size, 40 lbs. Capacity, 1" High	8
31	GVR-Compressor_Monitor_PCB_Sub-Assy	Compressor Monitor PCB Sub-Assembly	1
32	850-00042-01	LenovoM90t PC (& R90-19-17: RTX 4060 Video Card)	2
33	GVR-PC_Shelf_Sub-Assy	PC Mounting Shelf Sub-Assembly	1
34	Partec - 7-197	PC Foam Pad	1
35	601-00580-01	PC Wood Cleat	4
36	GVR-Filter_Regulatory_Sub-Assy	Filter/Regulator Sub-Assembly	1
37	GVR-Compressor_Shelf_Sub-Assy	Compressor Mounting Shelf Sub-Assembly	1
38	GVR-Compressor_Fan_Sub-Assy	Compressor Fan Sub-Assembly	1
39	GVR-Right_Front_Access_Door_Sub-Assy	Right Front Access Door Sub-Assembly (PC)	1
40	GVR-Left_Front_Access_Door_Sub-Assy	Left Front Access Door Sub-Assembly (Compressor)	1
41	603-01006-01	Drain Pan (22PP190)	1
42	603-01007-01	Drain Sponge	1
43	R1-1001	Drip Tray Access Cover	1
ALTERNATIVE ITEMS 11*-13* FOR LG 65UR340C MONITOR (120V ONLY)			
11*	R90-AP-22	LG 65UR340C Display (120V ONLY)	1
12*	McMaster-Carr - 91280A326	Medium-Strength Class 8.8 Steel Hex Head Screw, Zinc-Plated, M6 x 1mm Thread, 16 mm Long	4
13*	McMaster-Carr - 90377A159	Black-Oxide 18-8 Stainless Steel Washer, Oversized, 1/4" Screw Size, 0.266" ID, 1.5" OD	4



ITEM NO.	PART NUMBER	DESCRIPTION	QTY.
1	RAP-115	Side Logo Lightbox	1
2	CR-34	Lightbox LED: White Flexible LED Tape, w/ FOAM, 45&45CM (500-00162-01)	1
3	CR-35	Upper LED: White Flexible LED Tape, w/ FOAM, 40CM (500-00162-01)	1
4	CR-33	Lower LED: White Flexible LED Tape, w/ FOAM, 40CM (500-00162-01)	1
5	R4-1021	Side Logo End PETG Lens	2
6	McMaster-Carr - 96075A115	Alloy Steel Tamper-Resistant Button Head Torx Screws, 6-32 Thread, 1/2" Long	6
7	McMaster-Carr - 97416A113	Black-Oxide Steel SAE Washer for Number 8 Screw Size, 0.188" ID, 0.438" OD	14
8	R4-1022	Lightbox Spacer Panel A	1
9	R4-1023	Lightbox Spacer Panel B	1
10	McMaster-Carr - 90273A192	Zinc-Plated Steel Phillips Flat Head Screws, 82 Degree Countersink Angle, 8-32 Thread Size, 3/8" Long	6
11	R90-13-149	Side Logo Graphic PETG	1
12	McMaster-Carr - 96075A139	Alloy Steel Tamper-Resistant Button Head Torx Screws, 8-32 Thread, 1/2" Long	8
13	McMaster-Carr - 90133A013	Oil-Resistant Neoprene Rubber Sealing Washer for Number 10 Screw Size, 0.17" ID, 0.375" OD	8

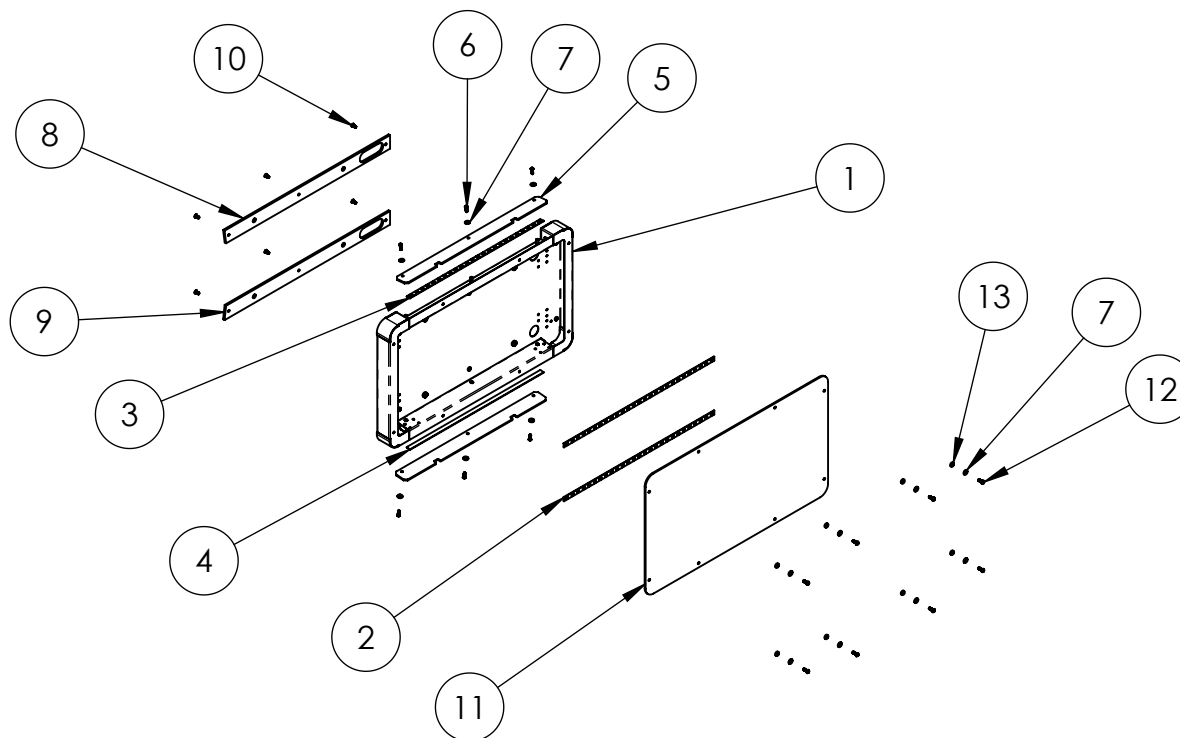

GODZILLA KAIJU WARS VR
 Right Logo Lightbox Sub-Assembly
 (Left is Mirrored)



ITEM NO.	PART NUMBER	DESCRIPTION	QTY.
1	600-03119-01	Solid State Relay Bracket	1
2	800-00079-01	Crouzet 84137910N, 25A Solid State Relay	1
3	McMaster-Carr - 90272A148	Zinc-Plated Steel Pan Head Phillips Screw, 6-32 Thread, 1/2" Long	2

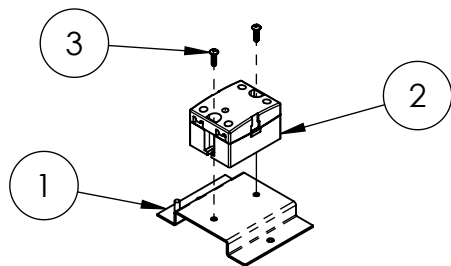

GODZILLA KAIJU WARS VR
Solid State Relay Sub-Assembly

ITEM NO.	PART NUMBER	DESCRIPTION	QTY.
4	600-02799-01	Line Filter Mounting Plate	1
5	R90-8-1	Corcom 16EQ1 Power Line Filter	1
6	McMaster-Carr - 90272A146	Zinc-Plated Steel Pan Head Phillips Screw, 6-32 Thread, 3/8" Long	2

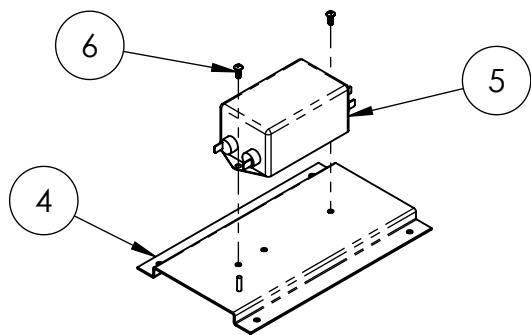

GODZILLA KAIJU WARS VR
Power Line Filter Sub-Assembly

ITEM NO.	PART NUMBER	DESCRIPTION	QTY.
7	600-01384-01	AC Double Inlet Plate	1
8	Marquardt - 1832.3312	Rocker Switch (DPST): 250VAC, 16A	2
9	Schurter - 4404.001	Thermal Circuit Breaker: 240VAC, 15A, Snap-in, Fuseholder, 1-Pole	2
10	Qualtek - 703W-00/08	AC Receptacle: 250V, 15A	2
11	McMaster-Carr - 90272A146	Zinc-Plated Steel Pan Head Phillips Screw, 6-32 Thread, 3/8" Long	4

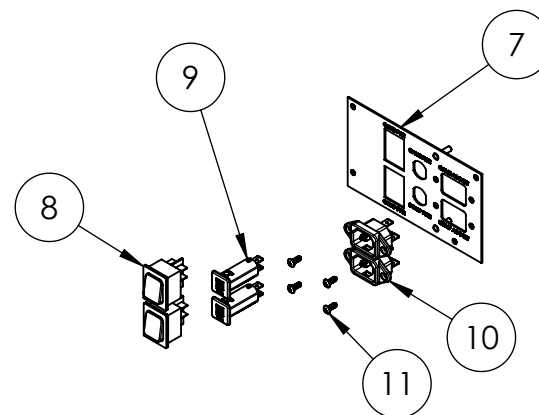

GODZILLA KAIJU WARS VR
Dual Inlet AC Power Plate Sub-Assembly



ITEM NO.	PART NUMBER	DESCRIPTION	QTY.
1	R90-23-4	PC Mounting Panel	1
2	600-00891-01	Securing Nylon Strap Plate	4
3	PC_Strap_Assy	Buckle Clasp (17-313-1 & 17-313-2) and Nylon Strap (17-312: 72")	2
4	McMaster-Carr - 90054A196	Flanged Hex Head Screws for Sheet Metal, Zinc-Plated Steel, Number 8 Size, 5/8" Long	8

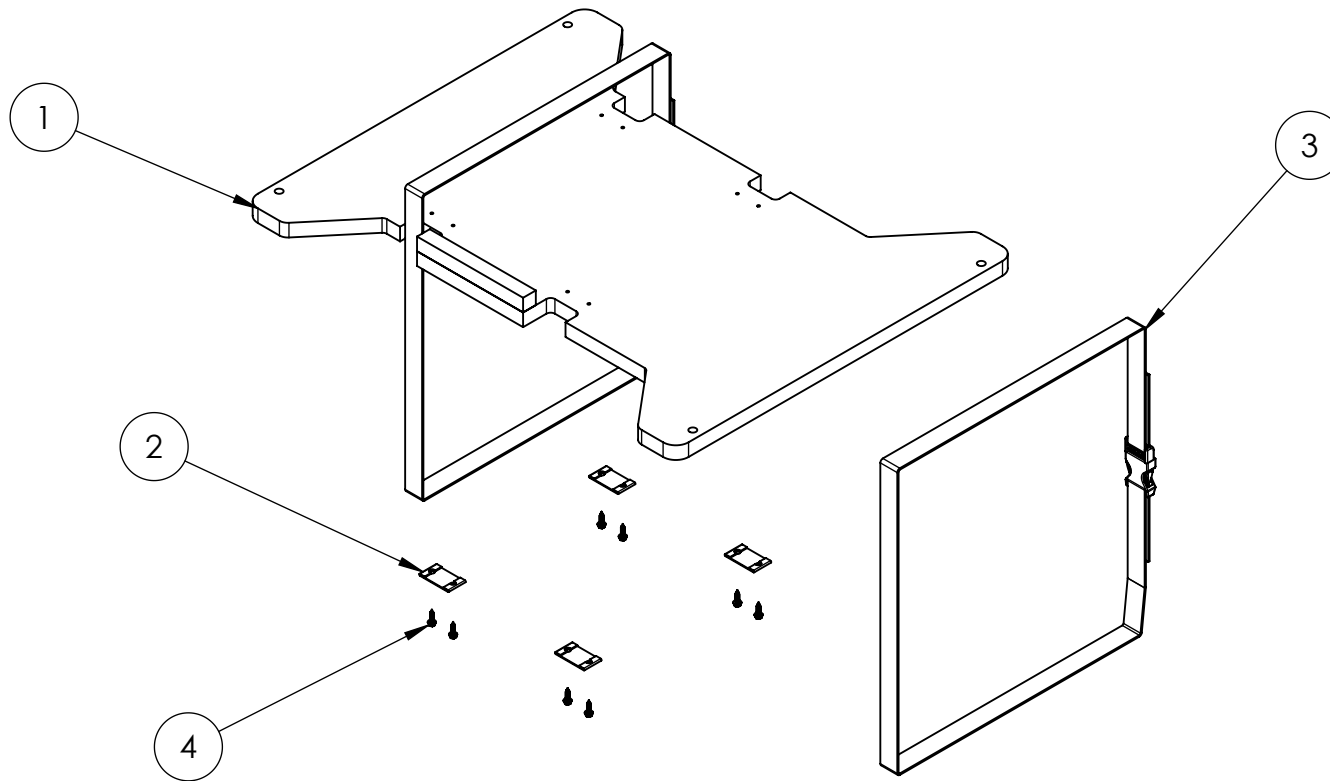

GODZILLA KAIJU WARS VR PC Mounting Shelf Sub-Assembly



ITEM NO.	PART NUMBER	DESCRIPTION	QTY.
1	600-02789-01	Compressor Monitor Board Bracket	1
2	500-00253-01	Compressor Thermal Monitor PCB	1
3	McMaster-Carr - 93075A192	Low-Strength Zinc-Plated Steel Hex Head Screws, 8-32 Thread Size, 3/8" Long	4

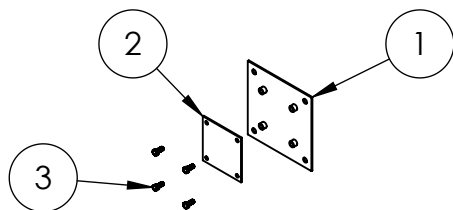

GODZILLA KAIJU WARS VR Compressor Monitor PCB Sub-Assembly

ITEM NO.	PART NUMBER	DESCRIPTION	QTY.
4	R1-1108	Universal Compressor Fan Mount	1
5	GVR-Standard_Fan_Sub-Assy	Fan (CA-3277) and Wire Grill (800-00001-00) Assembly	1
6	McMaster-Carr - 93075A203	Low-Strength Zinc-Plated Steel Hex Head Screws, 8-32 Thread Size, 1-1/2" Long	4
7	McMaster-Carr - 90631A009	Low-Strength Steel Nylon-Insert Locknut, Zinc-Plated, 8-32 Thread Size	4

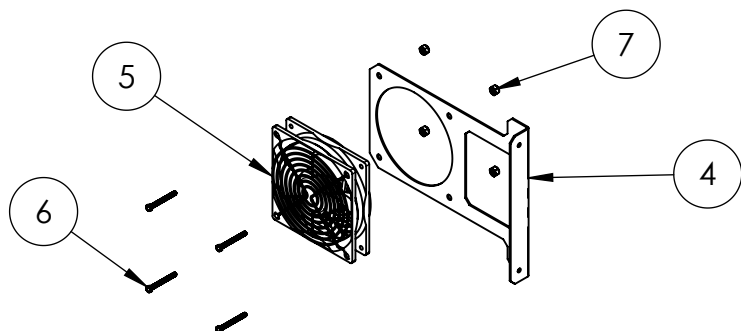

GODZILLA KAIJU WARS VR Compressor Fan Sub-Assembly

ITEM NO.	PART NUMBER	DESCRIPTION	QTY.
8	R90-AP-6	CKD-W3000-8N-W-F1X1: 1/4" NPT 5 micron Filter/Regulator w norm closed auto-drain, Right to Left Flow	1
9	604-00048-01	L-style Bracket for W3000-8N-W-F1	1
10	5779K391	Fitting-3/8 OD Push-to-Connect / 1/4 NPT Male- (5779K391)	1
11	5779K109	Push-to-Connect Tube Fitting for Air, Straight Adapter for 1/4" Tube OD x 1/4 NPT Male	1
12	44605K232	Plug, 1/4 Pipe Size	1

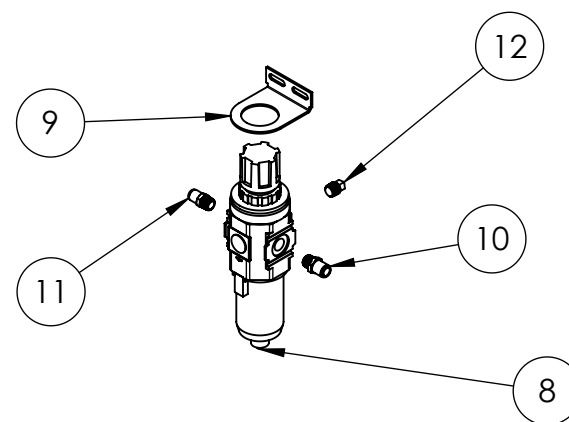

GODZILLA KAIJU WARS VR Filter/Regulator Sub-Assembly

ITEM NO.	PART NUMBER	DESCRIPTION	QTY.
1	R90-23-2	Compressor Mounting Panel	1
2	604-00066-01	Makita Quiet Series 1 HP, 2 Gallon, Oil Free, Electric Air Compressor, 120VAC, CSA/US Listed	1
3	600-02621-01	Compressor Bracket	2
4	McMaster-Carr - 92620A542	Zinc Yellow-Chromate Plated Hex Head Screw, Grade 8 Steel, 1/4"-20 Thread Size, 1" Long	4
5	McMaster-Carr - 91102A750	Zinc-Plated Steel Split Lock Washer for 1/4" Screw Size, 0.26" ID, 0.487" OD	4
6	GVR- Drain_Solenoid_Sub-Assy	Compressor Drain Solenoid Valve Sub-Assembly	1
7	McMaster-Carr - 90054A196	Flanged Hex Head Screws for Sheet Metal, Zinc-Plated Steel, Number 8 Size, 5/8" Long	2

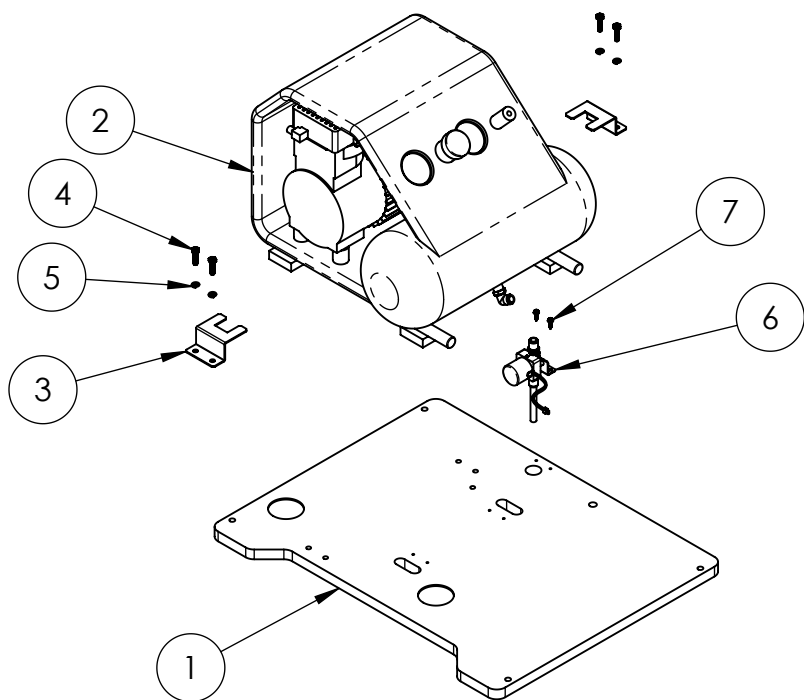

ITEM NO.	PART NUMBER	DESCRIPTION	QTY.
8	604-00073-01	CKD-AB21-02-1-DC12V: 1/4" NPT, 12VDC Direct Acting Solenoid Valve	1
9	5779K391	Fitting-3/8 OD Push-to-Connect / 1/4 NPT Male-BSPT C (52065K419)	2
10	1-2966	CKD Drain Valve Bracket	1
11	McMaster-Carr - 5648K71 (6in)	Firm Polyurethane Tubing for Air and Water, 1/4" ID, 3/8" OD	1
12	McMaster-Carr - 91420A320	Steel Phillips Flat Head Screws, M5 x 0.8 mm Thread, 10 mm Long	2

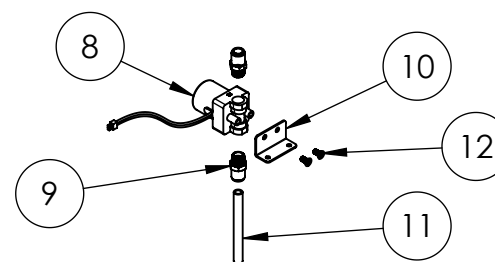

GODZILLA KAIJU WARS VR
Compressor Drain Solenoid Valve Sub-Assembly

GODZILLA KAIJU WARS VR
Compressor Mounting Shelf Sub-Assembly



ITEM NO.	PART NUMBER	DESCRIPTION	QTY.
1	R90-23-2	Compressor Mounting Panel	1
2	Compressor_Strap_Assy	Buckle Clasp (17-313-1 & 17-313-2) and Nylon Strap (17-312: 72")	1
3	600-00891-01	Securing Nylon Strap Plate	2
4	McMaster-Carr - 90054A196	Flanged Hex Head Screws for Sheet Metal, Zinc-Plated Steel, Number 8 Size, 5/8" Long	6
5	GVR-Drain_Solenoid_Sub-Assy	Compressor Drain Solenoid Valve Sub-Assembly	1
6	604-00077-01	Bambi EWS24 230V Compressor, 750W, 1 HP	1
7	McMaster-Carr - 92620A542	Zinc Yellow-Chromate Plated Hex Head Screw, Grade 8 Steel, 1/4"-20 Thread Size, 1" Long	1
8	McMaster-Carr - 91102A750	Zinc-Plated Steel Split Lock Washer for 1/4" Screw Size, 0.26" ID, 0.487" OD	1

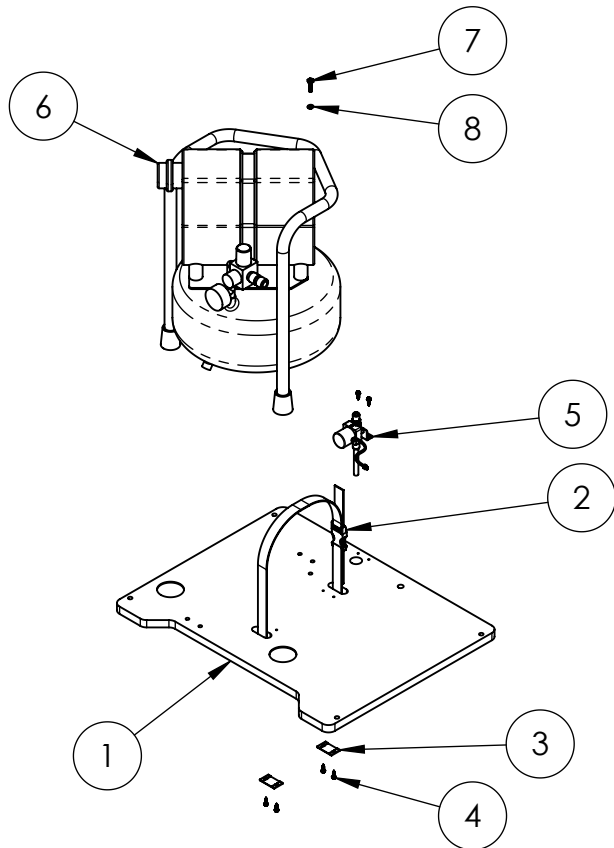

GODZILLA KAIJU WARS VR 230V Compressor Mounting Shelf Sub-Assembly



ITEM NO.	PART NUMBER	DESCRIPTION	QTY.
1	GVR-RIO2_Sub-Assy	RIO2 Assembly w/ Mounting Plate	1
2	AS-1870	Test/Service Button Sub-Assembly	1
3	R90-23-3	Front Access Door	1
4	600-00043-01	Lock Retainer Plate	1
5	McMaster-Carr - 90054A196	Flanged Hex Head Screws for Sheet Metal, Zinc-Plated Steel, Number 8 Size, 5/8" Long	10
6	150-00001-00	Standard Door Lock Assembly (for 3/4" Panels)	1
7	600-02496-01	Main Cab Door Hinge	1
8	Partec - 31-CB010-03-002	Black Oxide Steel Square-Neck Carriage Bolt, Low-Strength, 10-24 Thread Size, 1-1/4" Long	3
9	McMaster-Carr - 90675A011	Steel Locknut with External-Tooth Lock Washer, Zinc-Plated, 10-24 Thread Size	3
10	R90-13-145	Front Access Door Decal	1

ITEM NO.	PART NUMBER	DESCRIPTION	QTY.
3	R90-23-3	Front Access Door	1
4	600-00043-01	Lock Retainer Plate	1
5	McMaster-Carr - 90054A196	Flanged Hex Head Screws for Sheet Metal, Zinc-Plated Steel, Number 8 Size, 5/8" Long	3
6	150-00001-00	Standard Door Lock Assembly (for 3/4" Panels)	1
7	600-02496-01	Main Cab Door Hinge	1
8	Partec - 31-CB010-03-002	Black Oxide Steel Square-Neck Carriage Bolt, Low-Strength, 10-24 Thread Size, 1-1/4" Long	3
9	McMaster-Carr - 90675A011	Steel Locknut with External-Tooth Lock Washer, Zinc-Plated, 10-24 Thread Size	3
10	R90-13-145	Front Access Door Decal	1

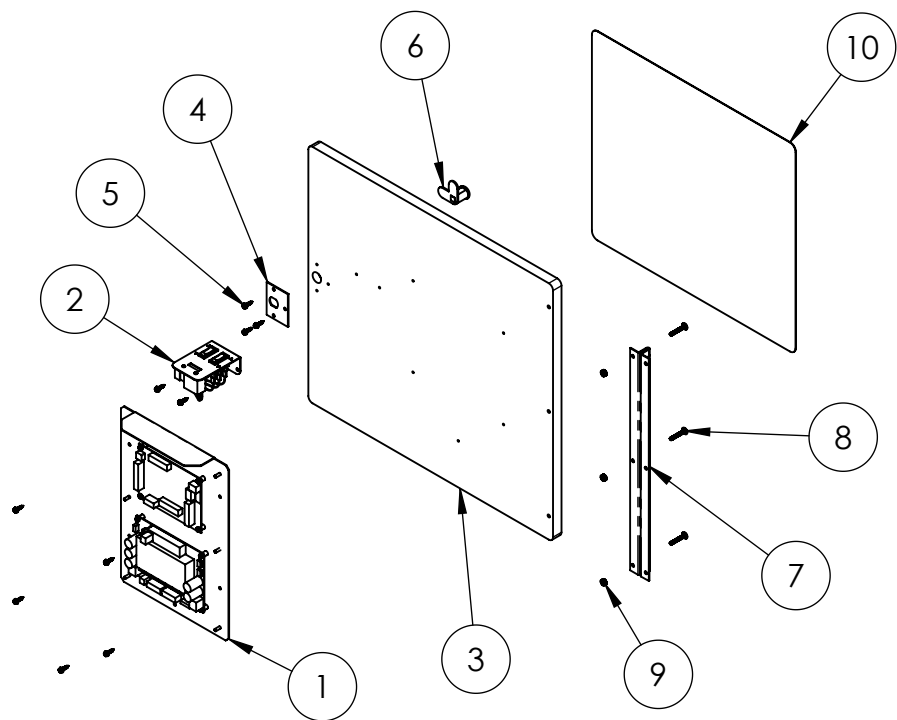

GODZILLA KAIJU WARS VR
Right Front Access Door Sub-Assembly (PC)

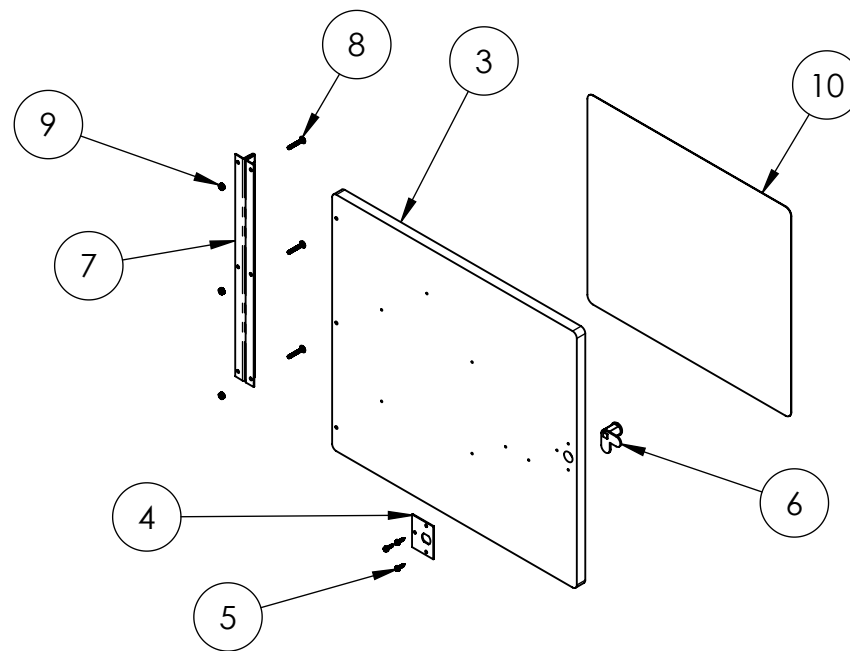

GODZILLA KAIJU WARS VR
Left Front Access Door Sub-Assembly (Compressor)



ITEM NO.	PART NUMBER	DESCRIPTION	QTY.
1	600-02604-01	RIO2 w/ 8 Channel Sound Mounting Plate	1
2	500-00199-05	RIO2 PCB	1
3	380-00010-01	8x50W USB-IN Audio Amplifier	1
4	McMaster-Carr - 93075A192	Low-Strength Zinc-Plated Steel Hex Head Screws, 8-32 Thread Size, 3/8" Long	8

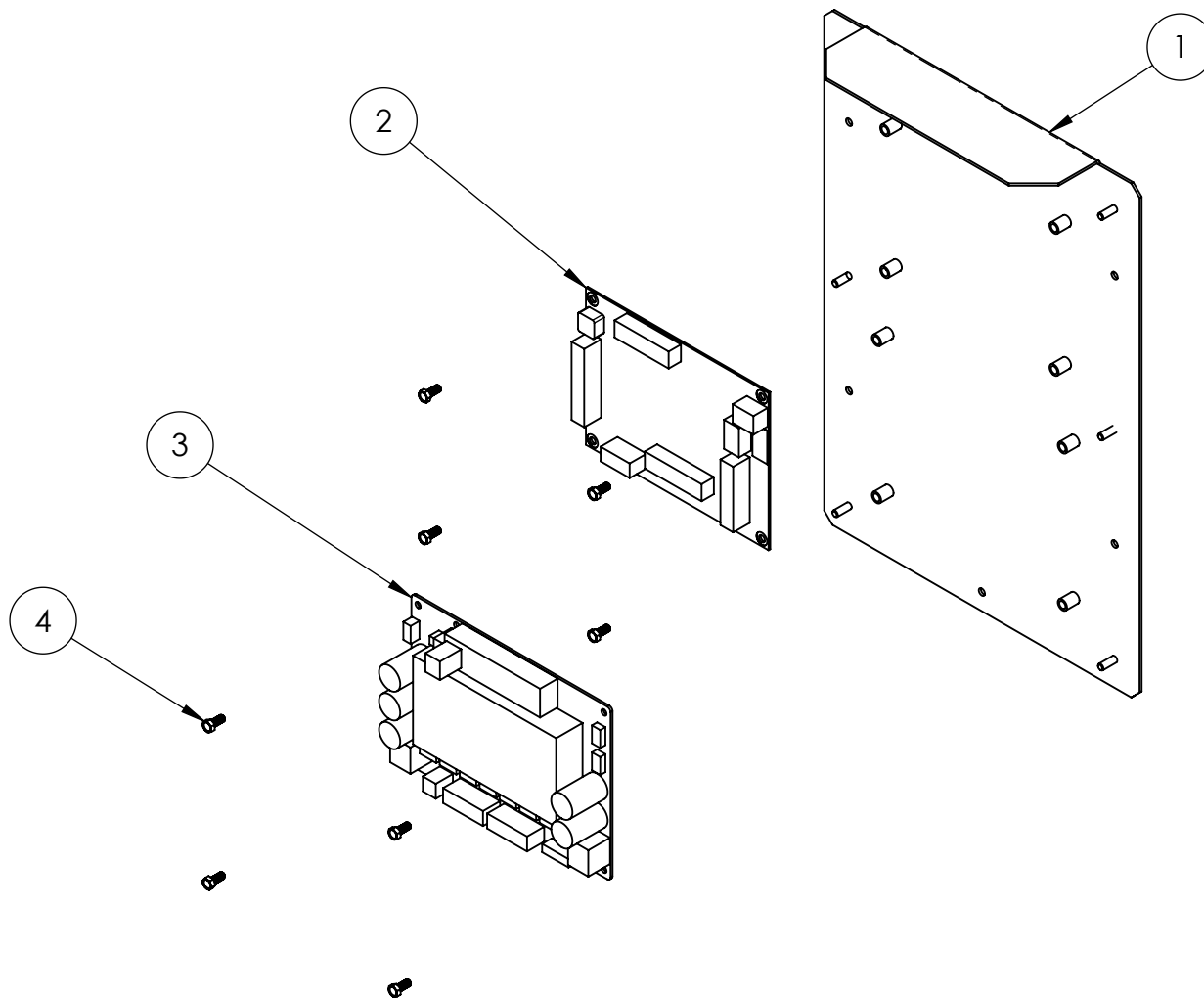

GODZILLA KAIJU WARS VR RIO2 Assembly w/ Mounting Plate



NOTE FOR PARTS 2-5:

- MONITORS CHANGE THROUGHOUT PRODUCTION
- ALL SHIPPED VERSIONS ARE INDICATED
- NOTE VOLTAGE SPECIFICATIONS

ITEM NO.	PART NUMBER	DESCRIPTION	QTY.
1	R1-1107	Universal 65" Monitor Hanger Bracket	1
ITEMS 2-5 FOR SAMSUNG QB65C DUAL VOLTAGE MONITOR (120V & 230V) - ALTERNATIVES LISTED AT END			
2	809-00016-01 (QB65C)	Samsung QB65C Display (DUAL VOLTAGE: 120V AND 230V)	1
3	603-01082-01	Samsung QB65 LCD Spacer	8
4	McMaster-Carr - 91280A546	Medium-Strength Class 8.8 Steel Hex Head Screw, Zinc-Plated, M8 x 1.25 mm Thread, 50 mm Long	4
5	McMaster-Carr - 91102A755	Zinc-Plated Steel Split Lock Washer for 5/16" Screw Size, 0.322" ID, 0.583" OD	4
ALTERNATIVE ITEMS 2*-5* FOR LG 65UR340C MONITOR (120V ONLY)			
2*	R90-AP-22	LG 65UR340C Display (120V ONLY)	1
4*	McMaster-Carr - 91280A326	Medium-Strength Class 8.8 Steel Hex Head Screw, Zinc-Plated, M6 x 1 mm Thread, 16 mm Long	4
5*	McMaster-Carr - 91102A750	Zinc-Plated Steel Split Lock Washer for 1/4" Screw Size, 0.26" ID, 0.487" OD	4

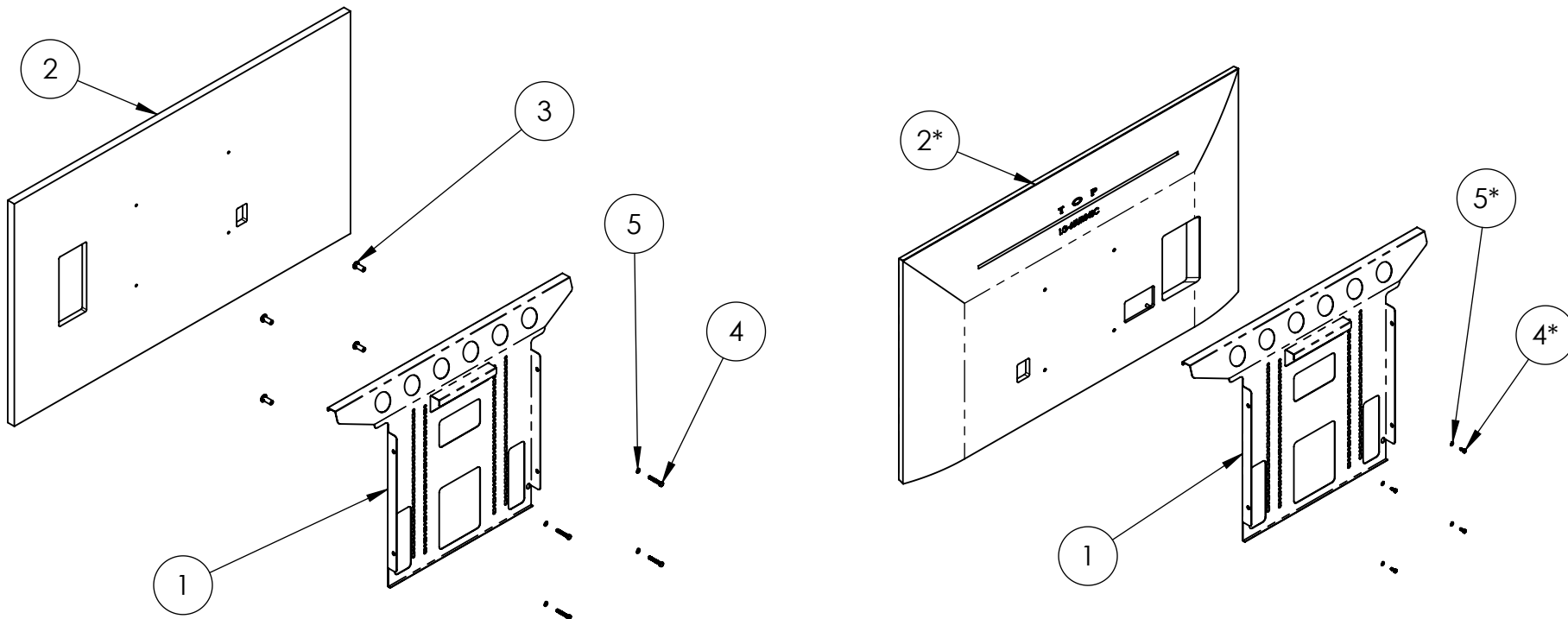

GODZILLA KAIJU WARS VR

Upper Monitor Hanger Sub-Assembly



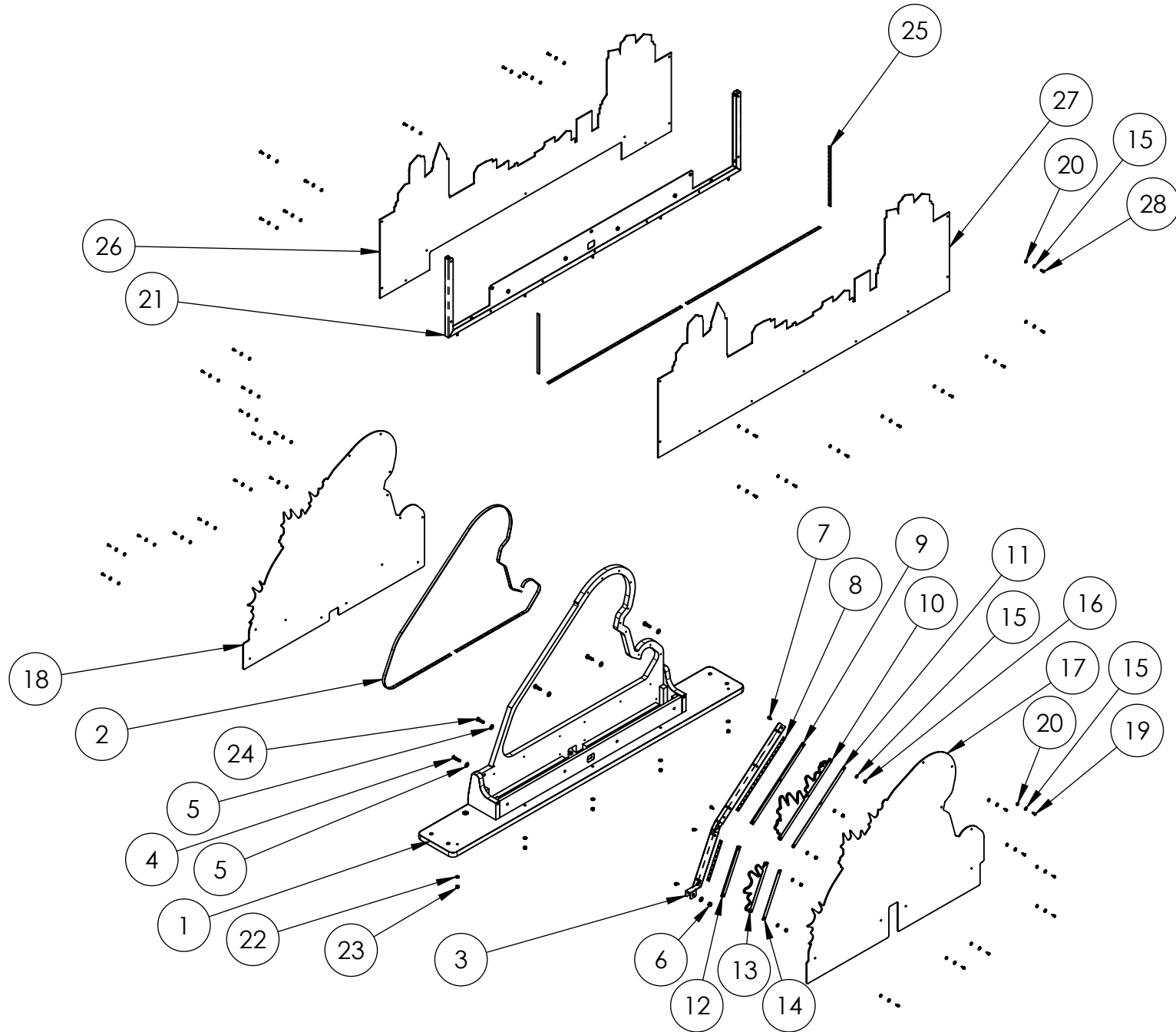

GODZILLA KAIJU WARS VR Topper Sub-Assembly



ITEM NO.	PART NUMBER	DESCRIPTION	QTY.
1	R90-23-25	Topper Cabinet	1
2	CR-45	Godzilla Body LED: White Flexible LED Tape, w/ FOAM, 160&55CM (500-00162-01)	1
3	RAP-117	Topper Spine Bracket	1
4	Partec - 31-TP250-03-001	Black Oxide Steel Tamper-Resistant Button Head Torx Screws, 1/4"-20 Thread Size, 1-1/4" Long	1
5	McMaster-Carr - 97416A119	Black-Oxide Steel SAE Flat Washer for 1/4" Screw Size, 0.281" ID, 0.625" OD	6
6	McMaster-Carr - 90640A129	Low-Strength Steel Nylon-Insert Locknut, Zinc-Plated, 1/4"-20 Thread Size	1
7	McMaster-Carr - 90054A196	Flanged Hex Head Screws for Sheet Metal, Zinc-Plated Steel, Number 8 Size, 5/8" Long	4
8	CR-46	Godzilla Spine LED: BLUE Flexible LED Tape, w/ FOAM, 30&15CM (500-00189-01)	1
9	R4-1026	Upper Dorsal Blocker Panel	1
10	R90-4-30	Upper Dorsal Plate Acrylic	1
11	R1-1116	Upper Dorsal Plate Cover	1
12	R4-1027	Lower Dorsal Blocker Panel	1
13	R90-4-31	Lower Dorsal Plate Acrylic	1
14	R1-1117	Lower Dorsal Plate Cover	1
15	McMaster-Carr - 97416A113	Black-Oxide Steel SAE Washer for Number 8 Screw Size, 0.188" ID, 0.438" OD	44
16	McMaster-Carr - 90631A009	Low-Strength Steel Nylon-Insert Locknut, Zinc-Plated, 8-32 Thread Size	5
17	R90-13-158	Godzilla Rear Graphic PETG	1
18	R90-13-157	Godzilla Front Graphic PETG	1
19	McMaster-Carr - 90935A194	Phillips Rounded Head Screws for Sheet Metal, Black-Oxide Steel, Number 8 Size, 1/2" Long	21
20	McMaster-Carr - 90133A013	Oil-Resistant Neoprene Rubber Sealing Washer for Number 10 Screw Size, 0.17" ID, 0.375" OD	39
21	R1-1113	Topper Building Bracket	1
22	McMaster-Carr - 97416A115	Black-Oxide Steel SAE Washer for Number 10 Screw Size, 0.219" ID, 0.5" OD	5
23	McMaster-Carr - 90631A411	Low-Strength Steel Nylon-Insert Locknut, Zinc-Plated, 10-32 Thread Size, 3/8" Wide, 15/64" High	5
24	McMaster-Carr - 92620A542	Zinc Yellow-Chromate Plated Hex Head Screw, Grade 8 Steel, 1/4"-20 Thread Size, 1" Long	4
25	CR-44	Buildings LED: White Flexible LED Tape, w/ FOAM, 65&65&25&25CM (500-00162-01)	1
26	R90-13-159	Building Front Graphic PETG	1
27	R90-13-160	Building Rear Graphic PETG	1
28	McMaster-Carr - 92224A156	Black Oxide Steel Pan Head Phillips Screw, 8-32 Thread Size, 1/2" Long	18

GODZILLA KAIJU WARS VR Topper Sub-Assembly



ITEM NO.	PART NUMBER	DESCRIPTION	QTY.
1	R1-1013	Platform Downlighting Bracket	1
2	R4-1001	Downlighting PETG Lens	1
3	McMaster-Carr - 94639A341	Off-White Nylon Unthreaded Spacer, 5/16" OD, 3/16" Long, for Number 8 Screw Size	3
4	CA-5017	RGB Flexible LED Tape, w/ FOAM, 40CM (500-00184-01)	1
5	R1-1078	Downlighting LED Plate	1
6	McMaster-Carr - 90675A009	Steel Locknut with External-Tooth Lock Washer, Zinc-Plated, 8-32 Thread Size, 11/32" Wide	3

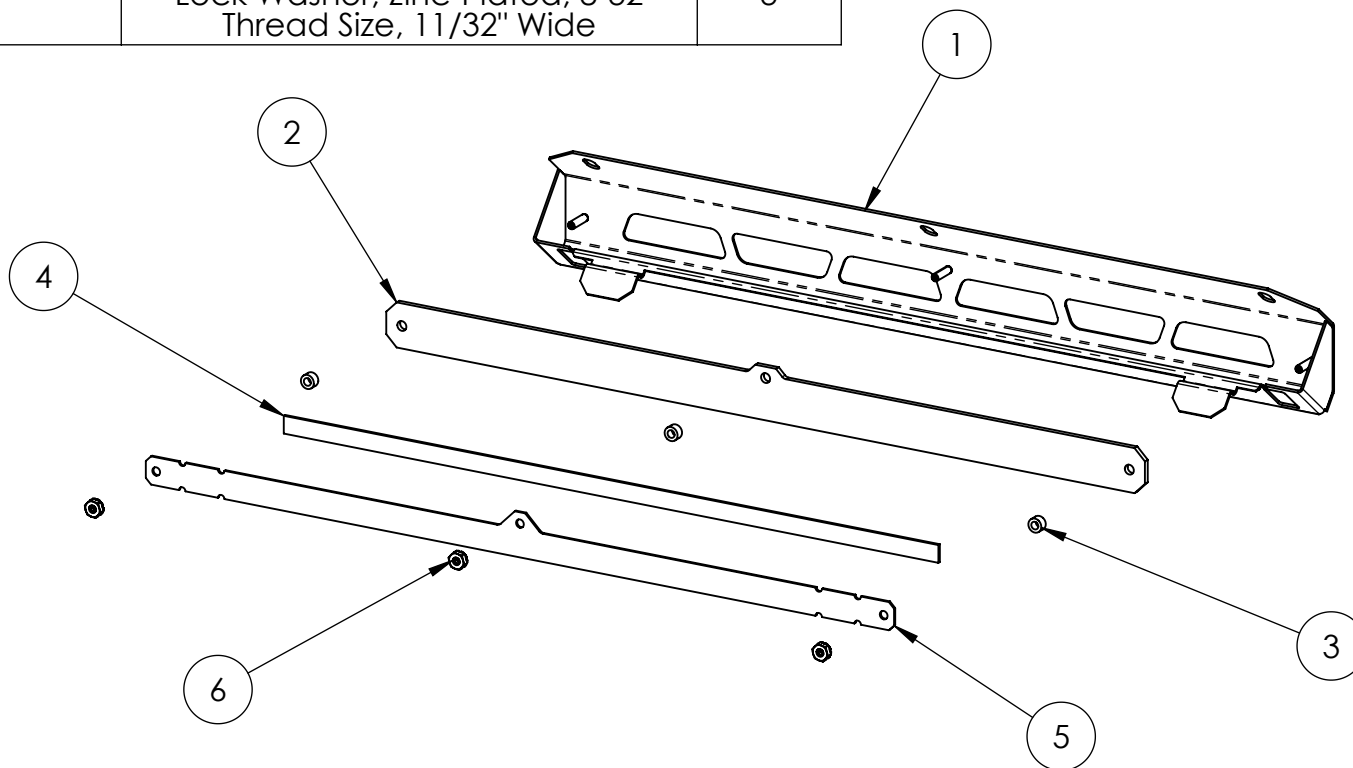

GODZILLA KAIJU WARS VR Platform Downlighting Sub-Assembly



ITEM NO.	PART NUMBER	DESCRIPTION	QTY.
1	R90-23-6	Upper Back Door	1
2	R90-13-22	Monitor Cabinet Upper Back Door Decal	1
3	800-00001-00	120mm Wire Fan Guard	2
4	Partec - 31-MS008-01-009	Zinc Plated Steel Pan Head Phillips Screw, 8-32 Thread, 1-1/8" Long	8
5	McMaster-Carr - 90126A512	Zinc-Plated Steel SAE Washer for Number 8 Screw Size, 0.188" ID, 0.438" OD	8
6	McMaster-Carr - 90631A009	Low-Strength Steel Nylon-Insert Locknut, Zinc-Plated, 8-32 Thread Size	8
7	600-00043-01	Lock Retainer Plate	1
8	McMaster-Carr - 90054A196	Flanged Hex Head Screws for Sheet Metal, Zinc-Plated Steel, Number 8 Size, 5/8" Long	3
9	150-00001-00	Standard Door Lock Assembly (for 3/4" Panels)	1

ITEM NO.	PART NUMBER	DESCRIPTION	QTY.
7	600-00043-01	Lock Retainer Plate	1
8	McMaster-Carr - 90054A196	Flanged Hex Head Screws for Sheet Metal, Zinc-Plated Steel, Number 8 Size, 5/8" Long	3
9	150-00001-00	Standard Door Lock Assembly (for 3/4" Panels)	1
10	R90-23-5	Lower Back Door	1
11	R90-13-21	Monitor Cabinet Lower Back Door Decal	1

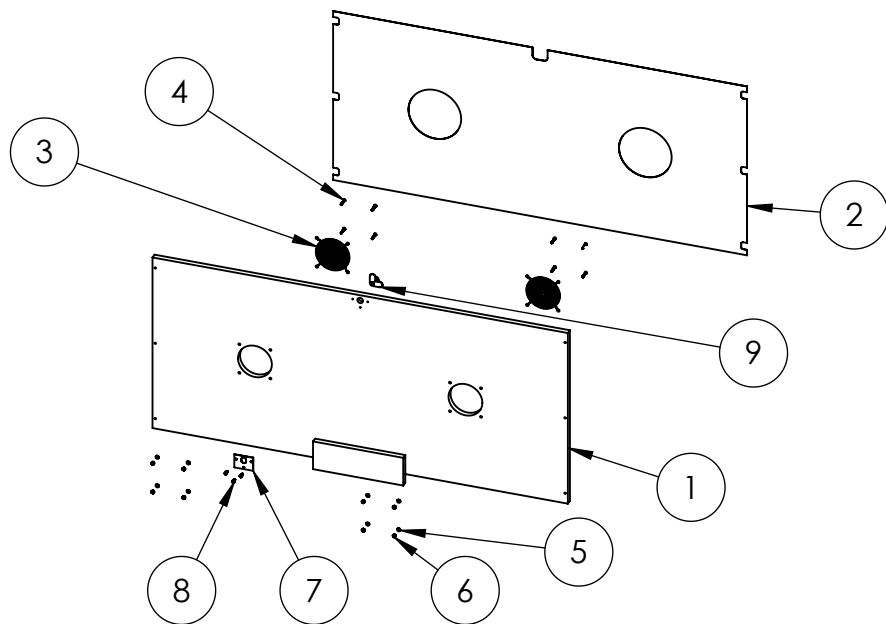

GODZILLA KAIJU WARS VR
Upper Back Door Sub-Assembly

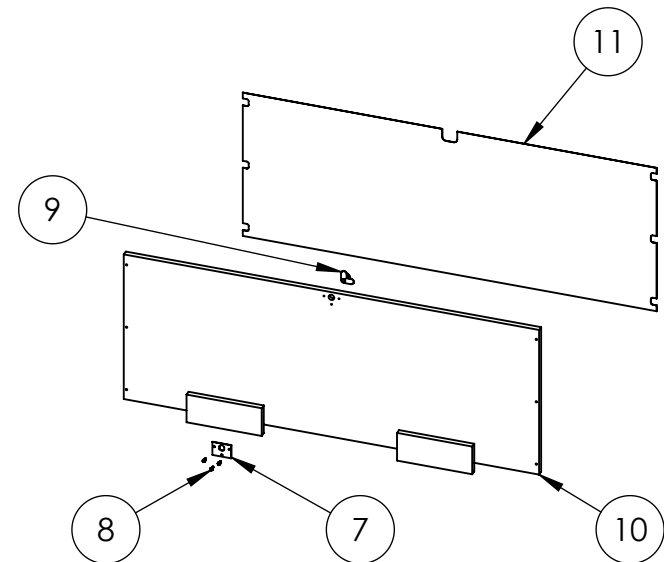

GODZILLA KAIJU WARS VR
Lower Back Door Sub-Assembly

ITEM NO.	PART NUMBER	DESCRIPTION	QTY.
1	R90-23-12	Spacer Cabinet	1
2	R90-13-26	Spacer Cap Floor Caution Decal	1
3	R90-13-25	Spacer Cap Side Caution Decal	2

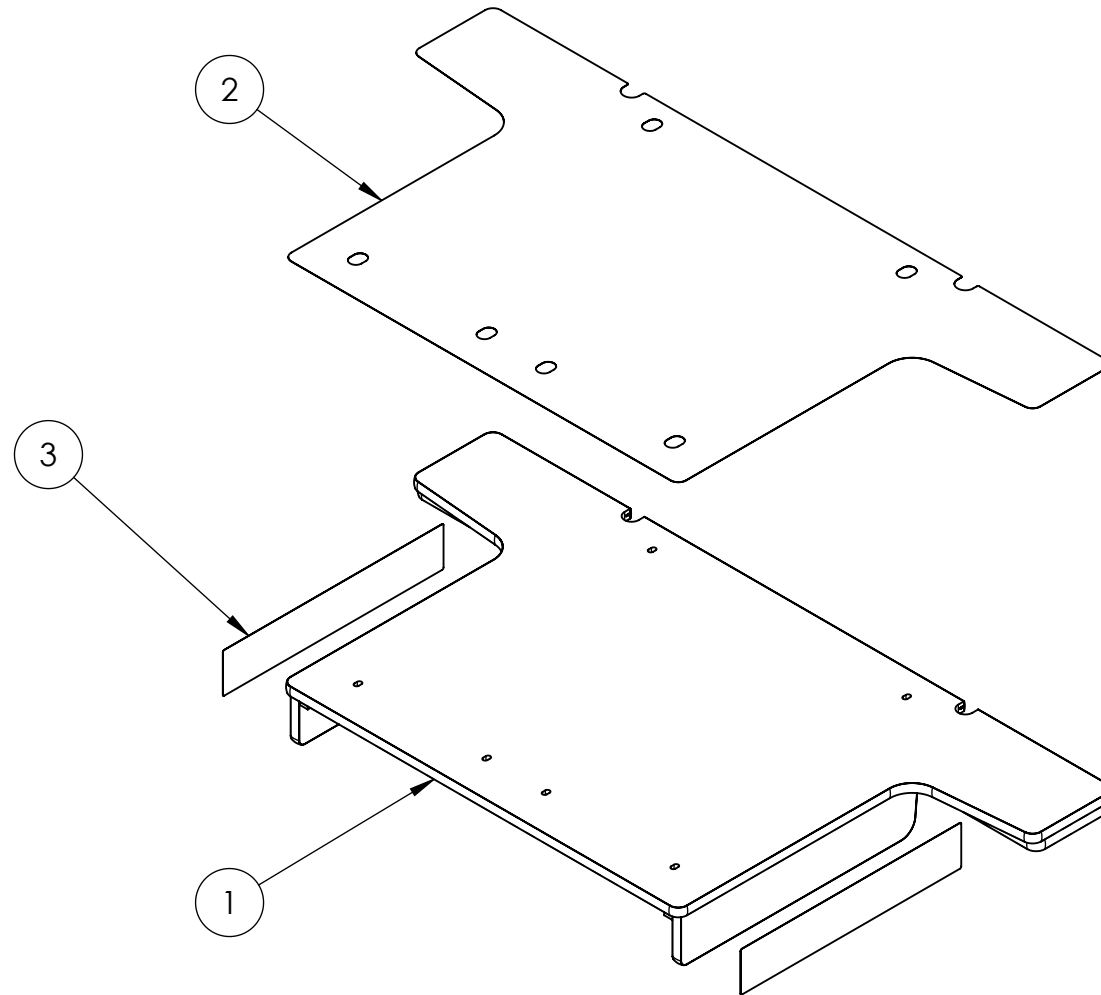

GODZILLA KAIJU WARS VR Spacer Cap Sub-Assembly



REV.	DESCRIPTION	DATE
A	RELEASED	2/2/24
B	NO CHANGES THIS SHEET	2/9/24
C	NO CHANGES THIS SHEET	2/13/24
D	ADDED A ZIP TIE AND A NOTE PAGE 3	3/19/24

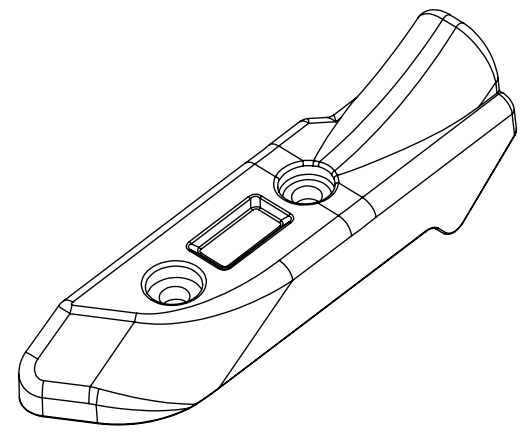

CABLE COVER

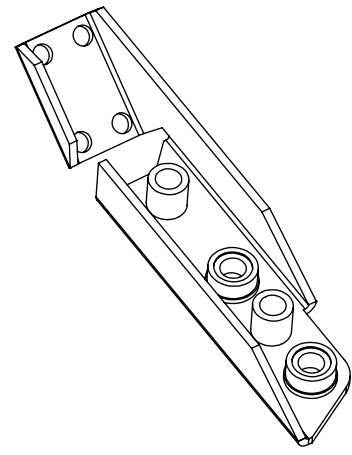

CABLE BRACKET

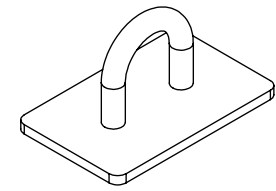

SECURITY BRACKET

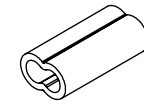

CRIMP (2)

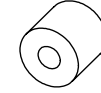

STOP CRIMP

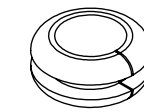

GROMMET (4)



SPRING



6-32 LOCK NUT (2)



6-32 x 3/8 PHILLIPS SCREW (2)



6-32 x 1/4 PHILLIPS SCREW - BLACK (4)

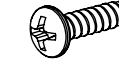

#6 PHILLIPS THREAD FORMING SCREW 1/2" LONG (6)

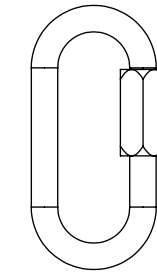

QUICK LINK

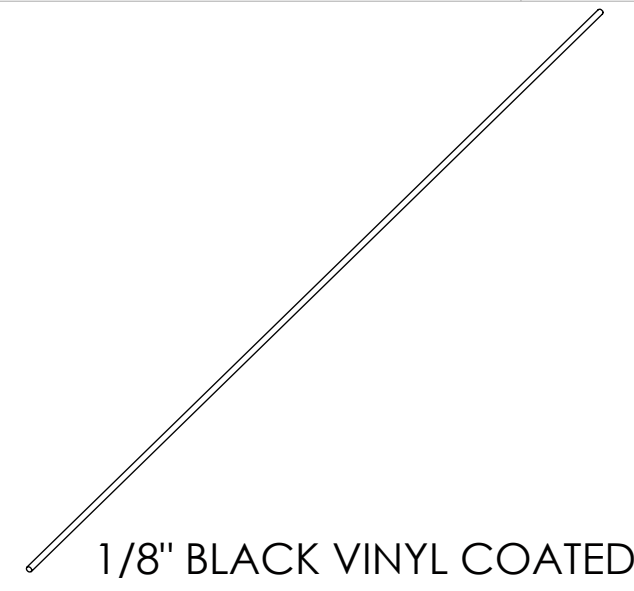

1/8" BLACK VINYL COATED CABLE (25.5" LONG)

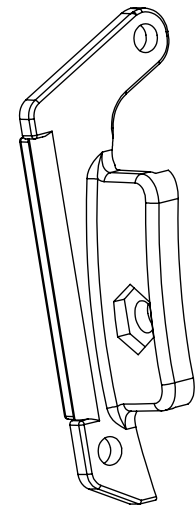

LEFT STRAP CLIP

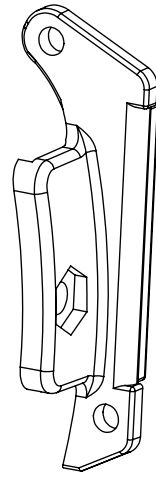

RIGHT STRAP CLIP

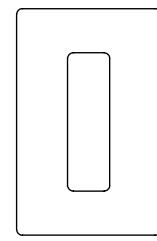

SECURITY BRACKET ADHESIVE



CRIMP HEAT SHRINK TUBING 1/2" x 1" LONG (3)



SLEEVING HEAT SHRINK TUBING 3/4" x 1 3/8" LONG (2)

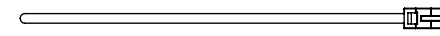

4" BLACK LOW PROFILE ZIP TIE (2)

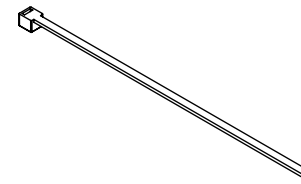

4" BLACK STANDARD ZIP TIE (10)

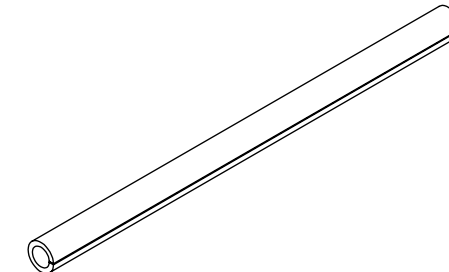

6" SPLIT TUBING (2)

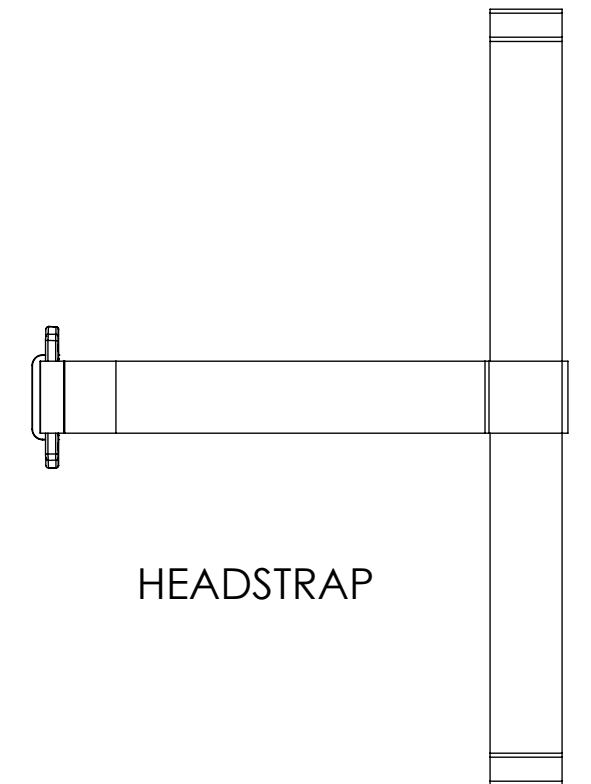

HEADSTRAP

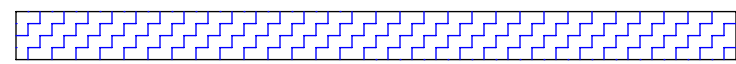

EXPANDABLE SLEEVING (8.5")

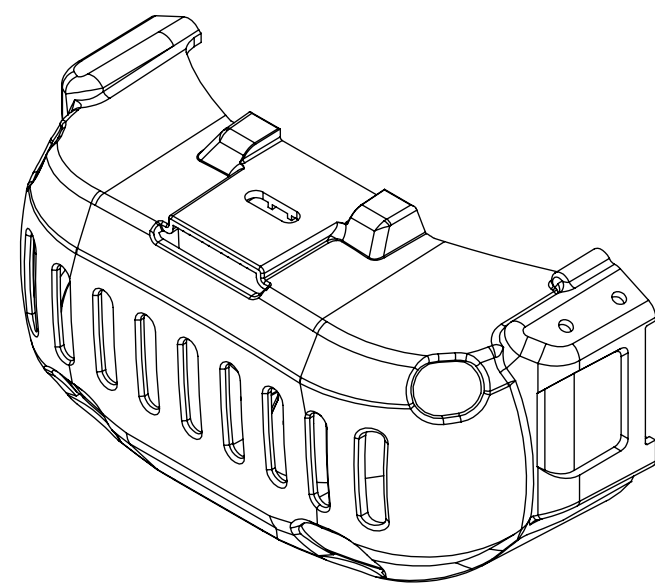

MAIN HOUSING

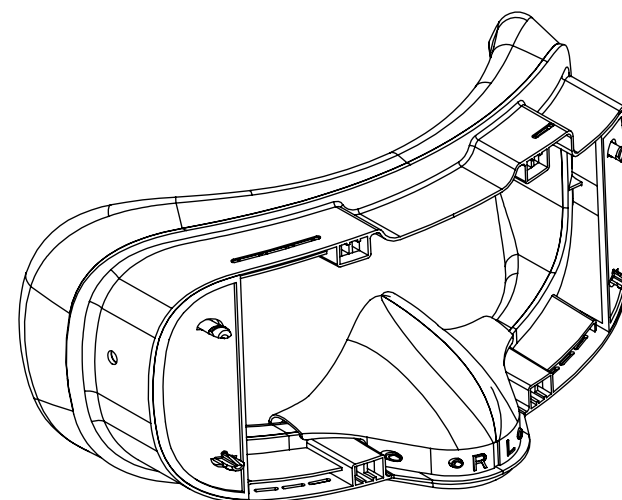

FACEMASK

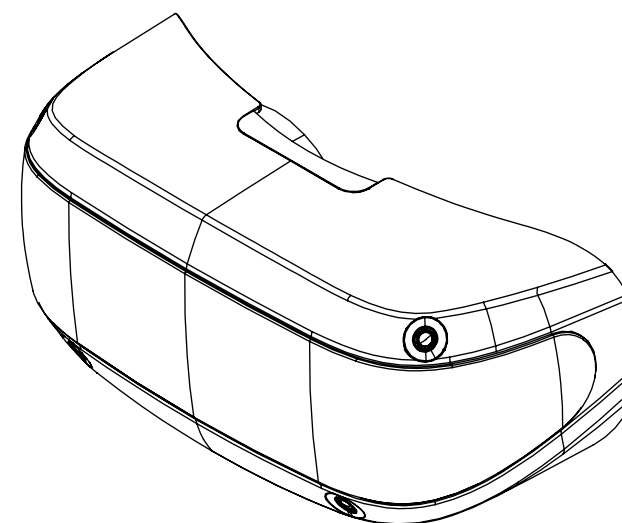

DPVR HEADSET

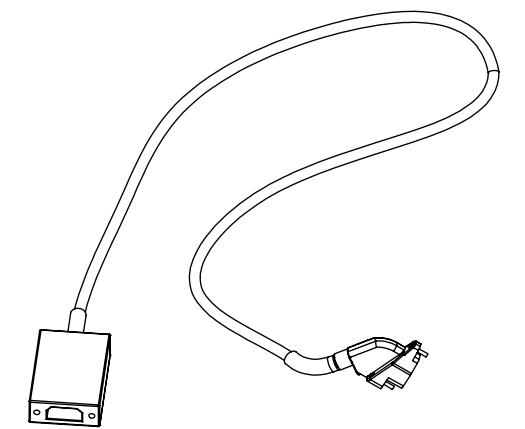

HEADSET CABLE

PARTS

RAW THRILLS INC.			
TITLE: DPVR HEADSET ASSEMBLY			
TOL: .X ±.030	MATERIAL:	SEE NOTES	
.XX ±.015	FINISH:	SEE NOTES	
.XXX ±.005	PART NO.	AS-4025	REV D
HOLES: +.002/-0.00	SHEET 1 of 3		
ANGLES: ±0.5°			

REV.	DESCRIPTION	DATE
A	RELEASED	2/2/24
B	ADDED LOCTITE NOTE	2/9/24
C	ADDED PARTEC PART NUMBERS	2/13/24
D	ADDED (1) LOW PROFILE ZIP TIE	3/19/24

APPLY BLUE LOCTITE
(242) TO THE THREADS

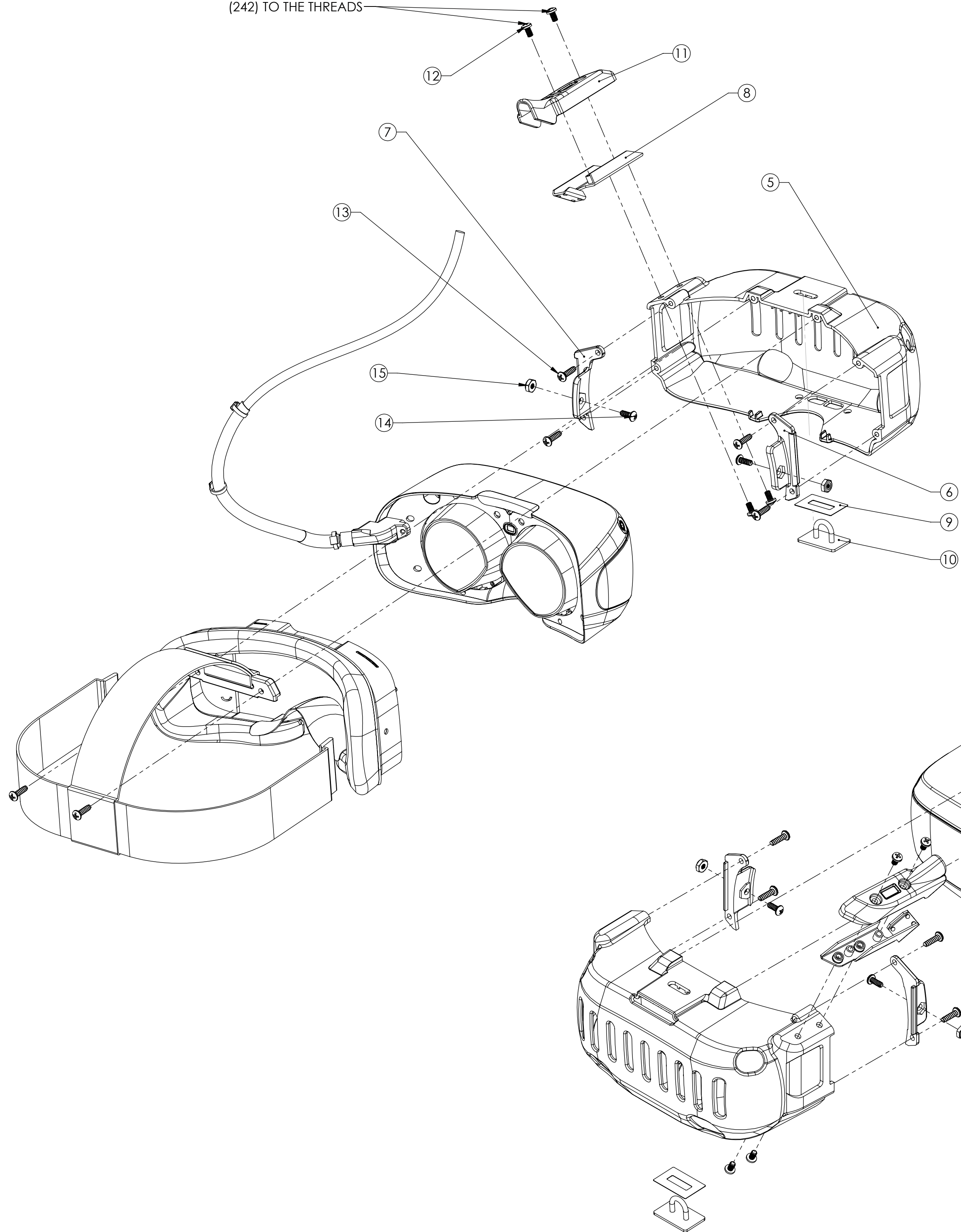

ITEM	QTY	PART NUMBER	DESCRIPTION
1	1	R90-AP-4	DPVR HEADSET
2	1	A577	FACEMASK
3	1	R90-8-2	HEADSET CABLE
4	1	A576-1	HEADSTRAP
5	1	R90-4-7	MAIN HOUSING
6	1	R90-4-10	RIGHT STRAP CLIP
7	1	R90-4-9	LEFT STRAP CLIP
8	1	R1-1066	CABLE BRACKET
9	1	R7-1005	SECURITY BRACKET ADHESIVE
10	1	AP-743-2	SECURITY BRACKET
11	1	R90-4-11	CABLE COVER
12	4	92224A131	SCREW - 6-32 X 1/4" PHILLIPS BLK
13	6	90417A126	SCREW - #6 THREAD FORMING 1/2" BLK
14	2	92224A133	SCREW - 6-32 X 3/8" PHILLIPS BLK
15	2	90633A007	NUT - 6-32 NYLOK
16	1	4-1114-2	SPLIT TUBING - 6"
17	1	4-114-2	4" ZIP TIE - BLK
18	2	4-114-12	4" LOW PROFILE ZIP TIE - BLK

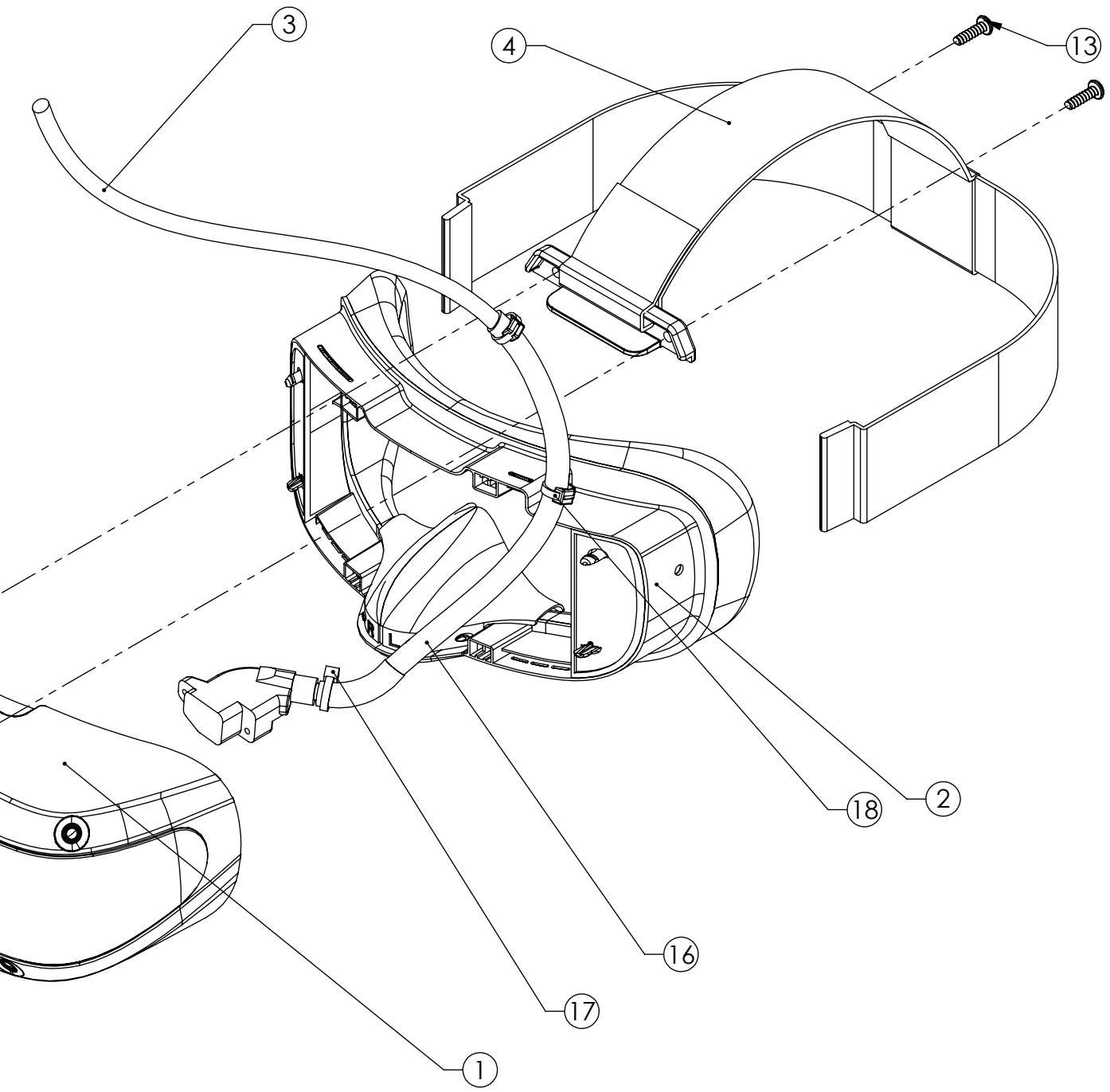

RAW THRILLS INC.

TITLE: DPVR HEADSET ASSEMBLY

TOL: .X ±.030
.XX ±.015
.XXX ±.005
HOLES: +.002/-0.000
ANGLES: ±0.5°

MATERIAL: SEE NOTES
FINISH: SEE NOTES
PART NO. AS-4025

SHEET 2 of 3

REV D

ITEM	QTY	PART NUMBER	DESCRIPTION
1	1	AP-788	QUICK LINK
2	1	600-03055-01	SPRING
3	1		SECURITY CABLE - 25.5" LONG
4	4	7-268	GROMMET
5	10		4" ZIP TIE
6	1	42-375-CON	3/8" EXPANDABLE SLEEVE 8.5"
7	1	4-1114-2	6" SPLIT TUBING
8	1	42-500-BHSPOLY	BLACK HEAT SHRINK TUBING 1/2" X 1.5"
9	3	42-375-BHSPOLY	BLACK HEAT SHRINK TUBING 3/8" X 1"
10	1	42-750-BHSPOLY	BLACK HEAT SHRINK TUBING 3/4" X 1.5"

REV.	DESCRIPTION	DATE
A	RELEASED	2/2/24
B	REVISED NOTES AND DRAWING	2/9/24
C	CHANGED ABLE LOOP LENGTH FROM 13" TO 16"	2/13/24
D	ADDED A LOW PROFILE ZIP TIE AND A NOTE ON SPLIT TUBING ORIENTATION	3/19/24

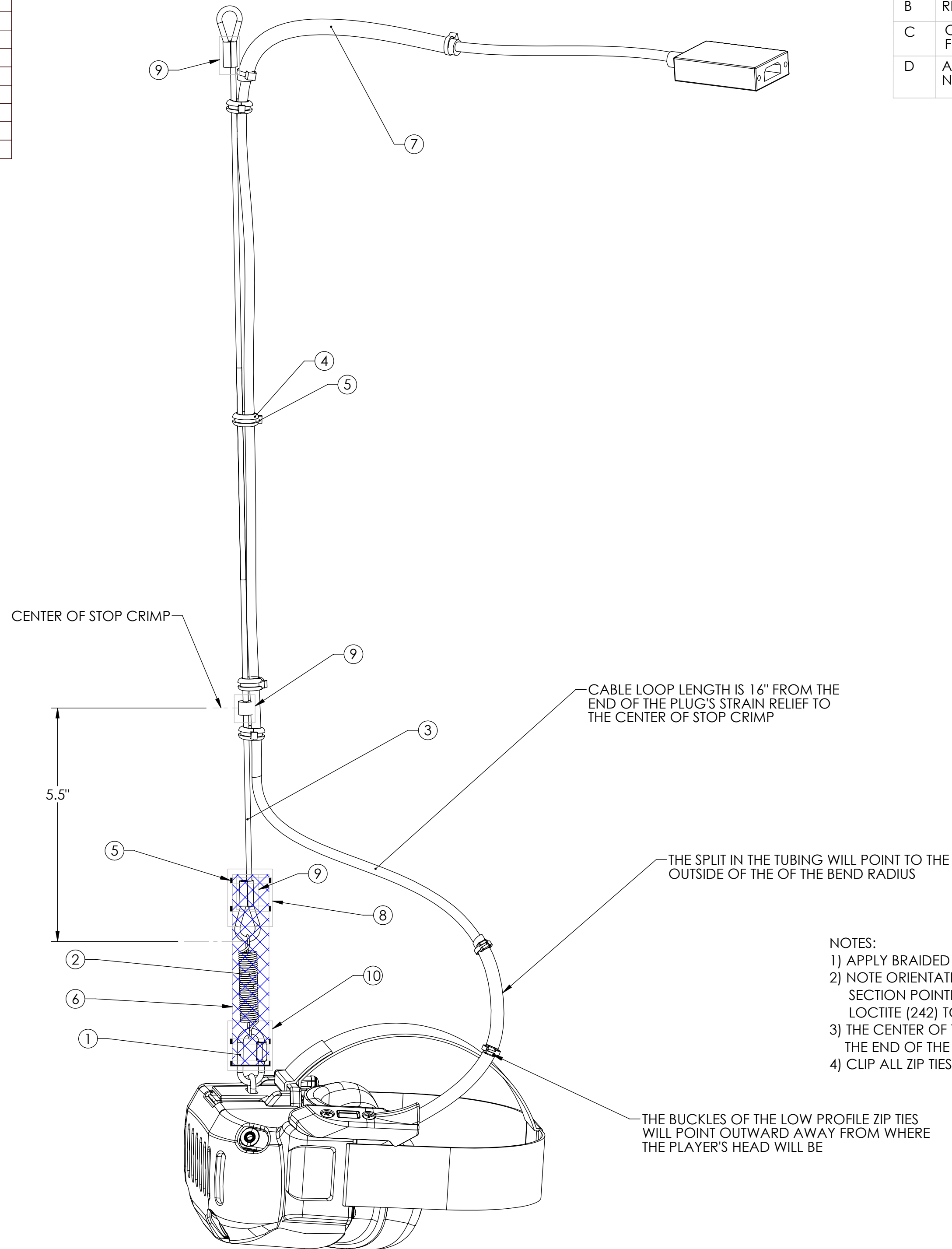

- NOTES:
- 1) APPLY BRAIDED SLEEVES AND HEAT SHRINK AS SHOWN.
 - 2) NOTE ORIENTATION OF THE QUICK LINK WITH THE LONGER SECTION POINTED TOWARD THE HEADSET. APPLY BLUE LOCTITE (242) TO THE THREAD BEFORE TIGHTENING.
 - 3) THE CENTER OF THE STOP CRIMP IS LOCATED 5.5" FROM THE END OF THE LOOP ON THE SECURITY CABLE.
 - 4) CLIP ALL ZIP TIES FLUSH SO THEY ARE NOT SHARP.

RAW THRILLS INC.			
TITLE:		DPVR HEADSET ASSEMBLY	
TOL: .X ±.030 .XX ±.015 .XXX ±.005	MATERIAL:	SEE NOTES	
HOLES: +.002/-0.000	FINISH:	SEE NOTES	
ANGLES: ±0.5°	PART NO.	AS-4025	REV D
SHEET 3 of 3			

REV.	DESCRIPTION	DATE
A	RELEASED	1/10/24

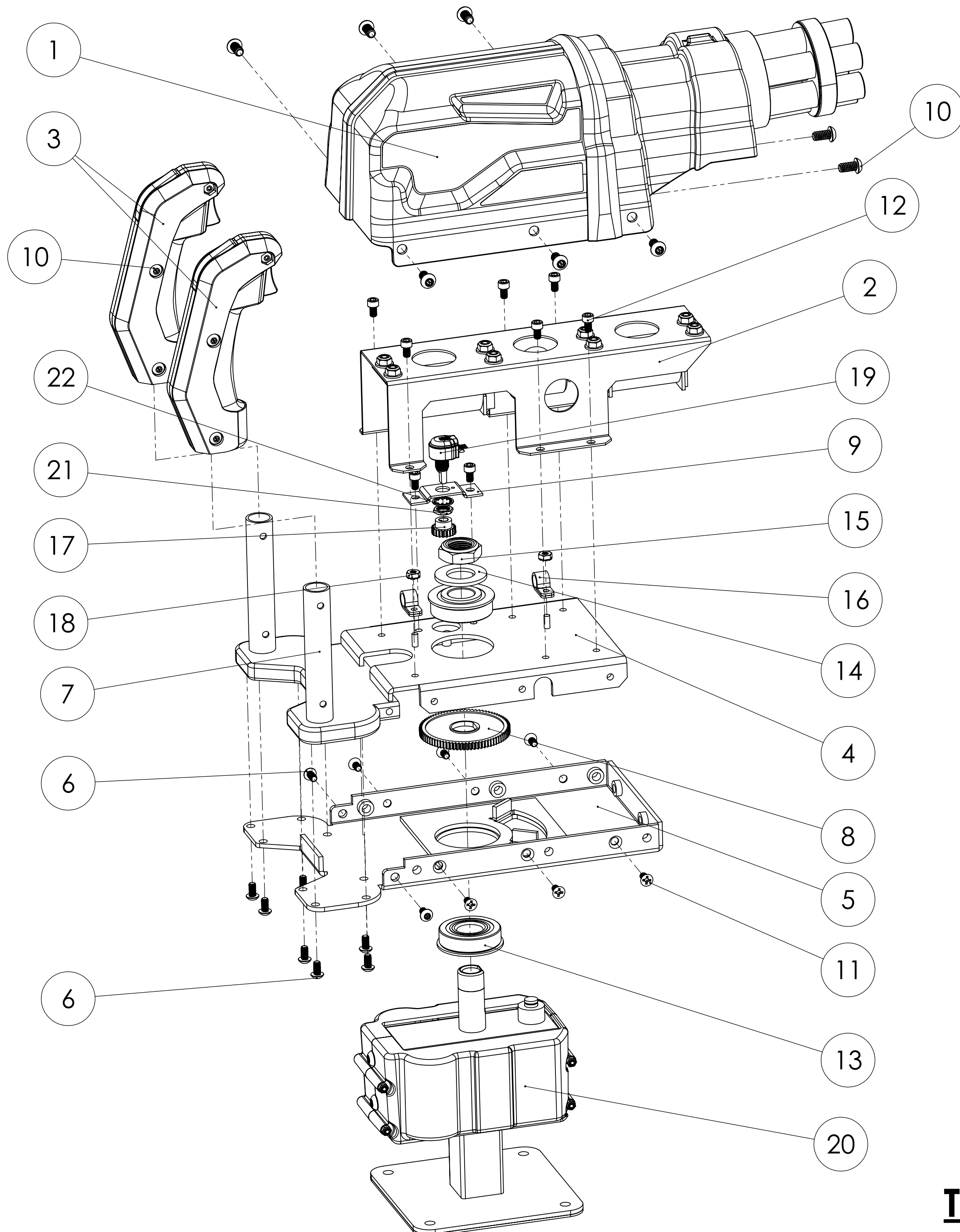

ITEM NO.	PART NUMBER	DESCRIPTION	Default/ QTY.
1		GUN COVER & TIP ASSEMBLY	1
2		SHAKER ASSEMBLY	1
3		GRIP ASSEMBLY	2
4	600-01422-01	PIN PLATE	1
5	600-01423-01	COVER BRACKET	1
6	MMC 96075A183	10-32 x 3/8" BLK TP SCREW	10
7	600-01411-01	GRIP PLATE WELDMENT	1
8	600-01420-01	LARGE GEAR	1
9	600-01491-01	POT BRACKET	1
10	MMC 96075A211	1/4-20 X 1/2" BLK TP SCREW	20
11	MMC 90273A827	10-32 X 3/8" FLAT HEAD SCREW	6
12	MMC 91251A337	10-32 X 5/16" CAP SCREW	8
13	MMC 6384K369	3/4" FLANGED BEARING	2
14	MMC 90126A036	3/4" WASHER	1
15	MMC 91342A240	3/4" LOCKNUT	1
16		CABLE CLAMP	2
17	600-01567-01	SMALL POT GEAR	1
18	MMC 90675A009	8-32 LOCKNUT	2
19	604-00064-01	360° JACKPOT	1
20		LOWER MECH ASSEMBLY	1
21	MMC 91862A521	3/8"-32 NUT	1
22	MMC 91113A031	3/8" INTOOTH WASHER	1

NOTES:

- 1) ALL SCREWS SHOULD BE INSTALLED WITH BLUE LOCTITE 242 or 243.
- 2) THE 3/4" LOCKNUT (15) IS TIGHTENED UNTIL THE TOP IS FLUSH WITH THE TOP OF THE TUBE IN THE LOWER MECH ASSEMBLY (20).

TOP ASSEMBLY

RAW THRILLS INC.	
TITLE: GVR GUN MAIN ASSEMBLY	
TOL: .X ±.030 .XX ±.015 .XXX ±.005	MATERIAL:
HOLES: +.002/-0.000	FINISH: SEE NOTES
ANGLES: ±0.5°	PART NO.
SHEET 1 of 3	REV A

REV.	DESCRIPTION	DATE
A	RELEASED	1/9/24

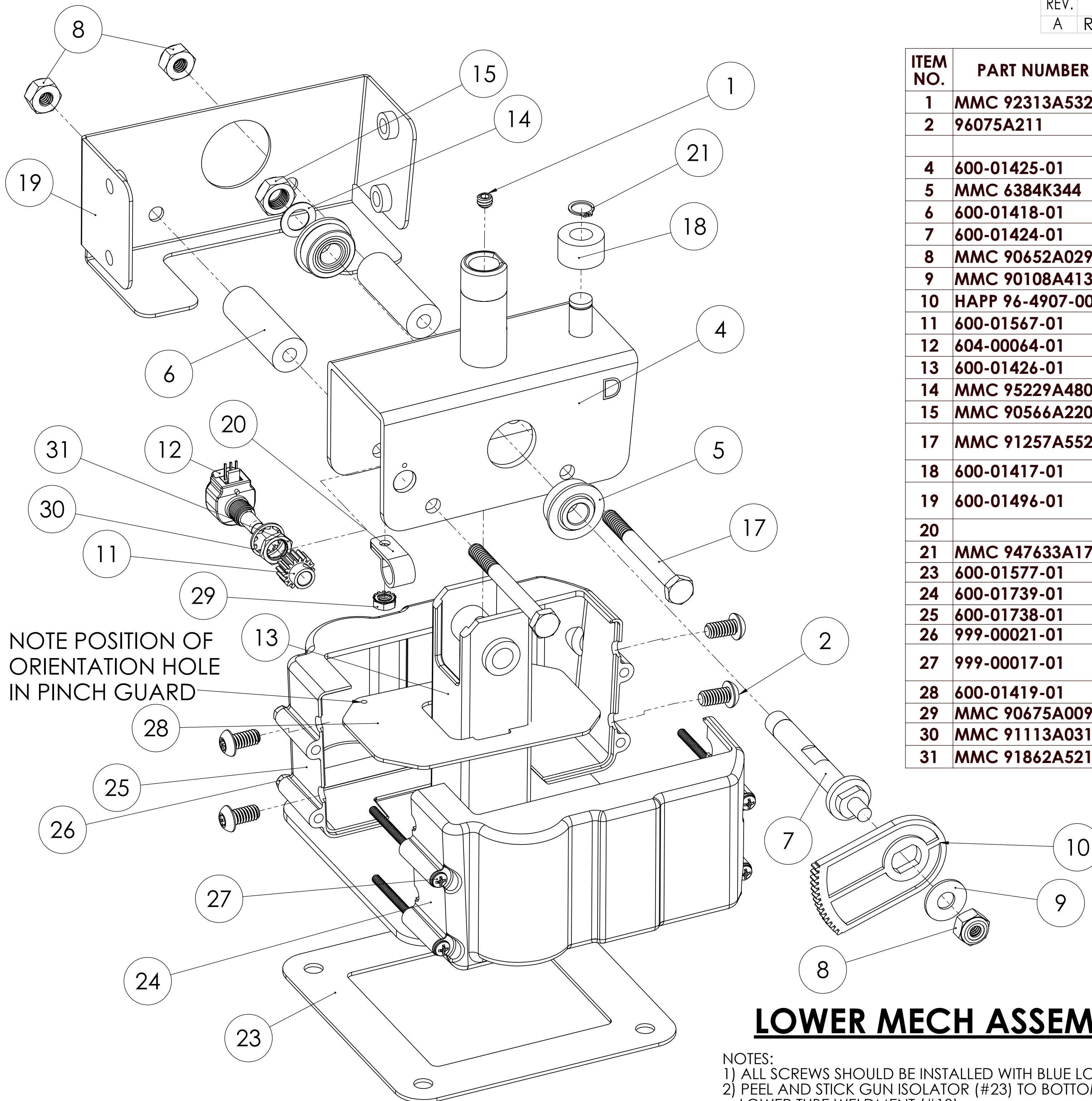

NOTE POSITION OF ORIENTATION HOLE IN PINCH GUARD

ITEM NO.	PART NUMBER	DESCRIPTION	QTY.
1	MMC 92313A532	1/4-20 x 3/16" SET SCREW	1
2	96075A211	1/4-20 x 1/2" BLACK TP SCREW	4
4	600-01425-01	ROCKER BRACKET	1
5	MMC 6384K344	3/8" FLANGED BEARING	2
6	600-01418-01	TUBE STOP BUMPER - 5/8" OD	2
7	600-01424-01	SIDE PIN	1
8	MMC 90652A029	1/4-20 THIN LOCKNUT	3
9	MMC 90108A413	1/4-20 WASHER	1
10	HAPP 96-4907-00	SEGMENT GEAR	1
11	600-01567-01	POT GEAR	1
12	604-00064-01	360° JACKPOT	1
13	600-01426-01	LOWER TUBE WELDMENT	1
14	MMC 95229A480	3/8" WASHER	1
15	MMC 90566A220	3/8" THIN LOCKNUT	1
17	MMC 91257A552	1/4-20 x 2 1/2 HEX HEAD - GRADE 8	2
18	600-01417-01	SHORT STOP BUMPER - 3/4" OD	1
19	600-01496-01	LOWER VACFORM MOUNTING BRACKET	1
20		CABLE CLAMP	1
21	MMC 947633A170	RETAINING CLIP	1
23	600-01577-01	GUN ISOLATOR	1
24	600-01739-01	BOTTOM COVER - RIGHT	1
25	600-01738-01	BOTTOM COVER - LEFT	1
26	999-00021-01	6-32 HEX LOCKNUT - BLACK	4
27	999-00017-01	6-32 X 2.5" PHILLIPS HEAD SCREW - BLACK	4
28	600-01419-01	PINCH COVER	1
29	MMC 90675A009	8-32 KEPS NUT	1
30	MMC 91113A031	3/8" INTOOTH WASHER	1
31	MMC 91862A521	3/8"-32 NUT	1

LOWER MECH ASSEMBLY

- NOTES:
 1) ALL SCREWS SHOULD BE INSTALLED WITH BLUE LOCTITE 242 or 243.
 2) PEEL AND STICK GUN ISOLATOR (#23) TO BOTTOM OF LOWER TUBE WELDMENT (#13)

RAW THRILLS INC.	
TITLE: GVR GUN MAIN ASSEMBLY	
TOL: .X ±.030 .XX ±.015 .XXX ±.005	MATERIAL:
HOLES: +.002/-0.000	FINISH: SEE NOTES
ANGLES: ±0.5°	PART NO.
SHEET 2 of 3	REV A

REV.	DESCRIPTION	DATE
A	RELEASED	1/10/24

ITEM NO.	PART NUMBER	DESCRIPTION	QTY.
1	600-01576-01	COIL MOUNT BRACKET	4
2	600-01412-01	COIL BRACKET	1
3	Pin Coil		2
4	600-01413-01	COIL ROD	1
5	600-01414-01	COIL WEIGHT	1
6	MMC 91375A535	1/4-20 x 3/8" SET SCREW	1
7	680-00214-01	BLUE DAMPER PAD	2
8	608-00210-01	COIL SPRING	2
9	Happ Sleeve #95-0637-00	COIL SLEEVE	2
10	MMC 93298A109	10-32 FLANGED LOCKNUT	8

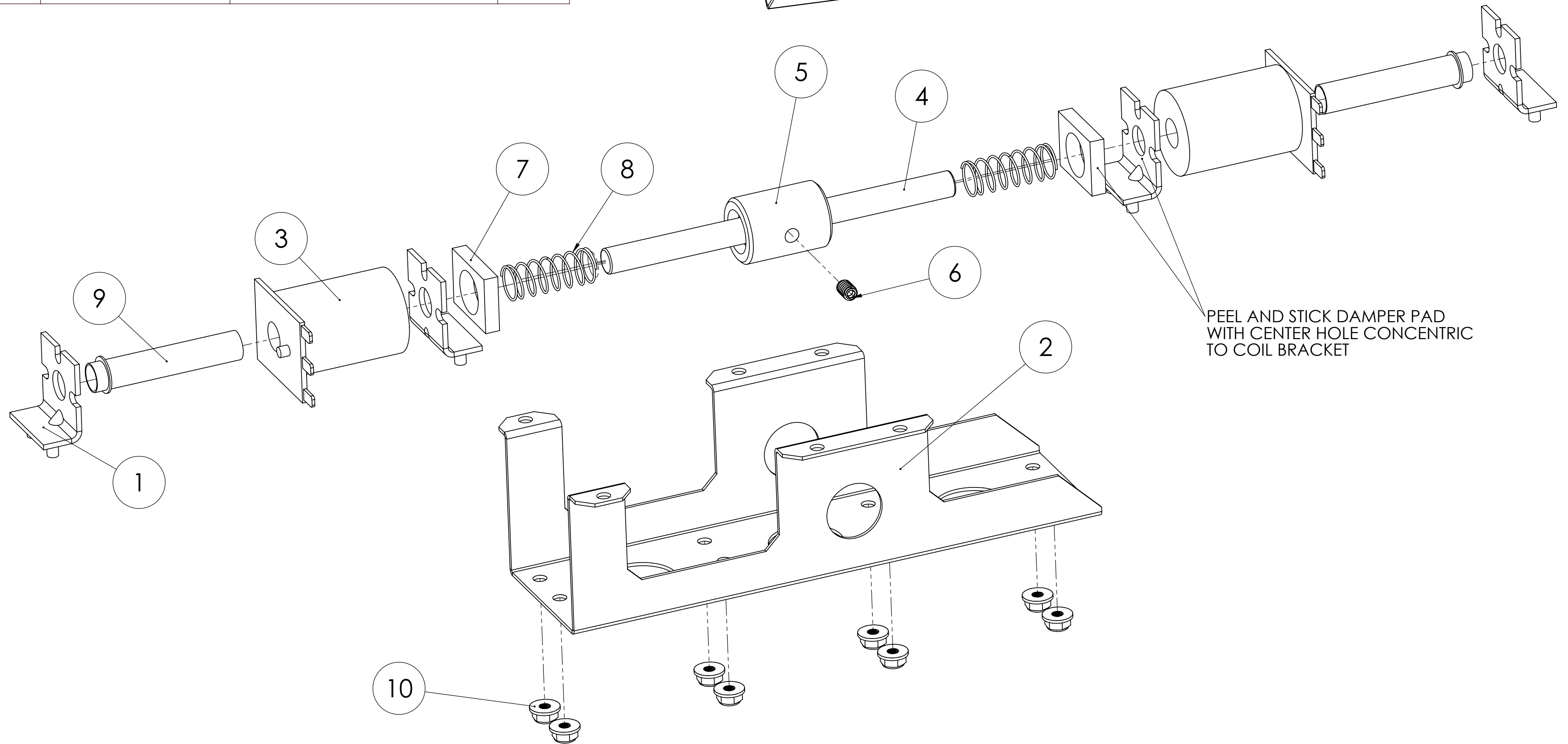
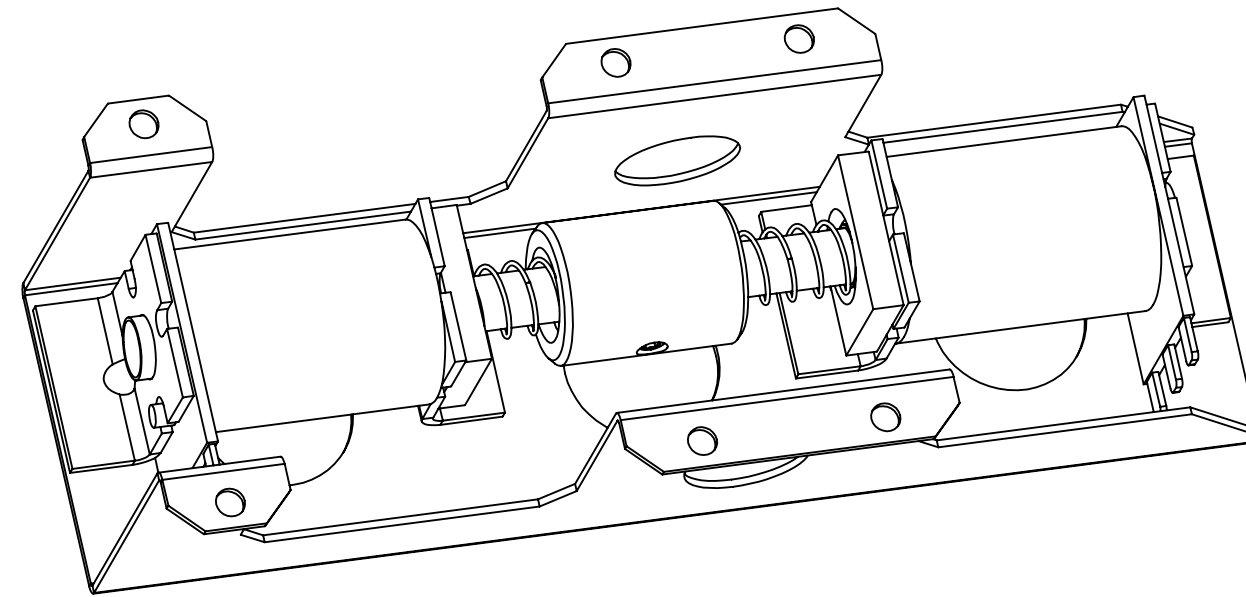

SHAKER ASSEMBLY

NOTES:

1) SET SCREW AND LOCKNUTS SHOULD BE INSTALLED WITH RED LOCTITE 262.

RAW THRILLS INC.	
TITLE: GVR GUN MAIN ASSEMBLY	
TOL: .X ±.030 .XX ±.015 .XXX ±.005	MATERIAL:
HOLES: +.002/-0.000	FINISH: SEE NOTES
ANGLES: ±0.5°	PART NO.
SHEET 3 of 3	REV A

REV.	DESCRIPTION	DATE
A	RELEASED	10/20/15
B	REVISED VIEW OF POT ORIENTATION	10/23/19

2) INSTALL SEGMENT GEAR AFTER POT IS ALIGNED FOR EASIER ACCESS TO GEAR SET SCREW. THE CENTER OF THE SEGMENT GEAR SHOULD POINT TO THE CENTER OF THE POT AS SHOWN.

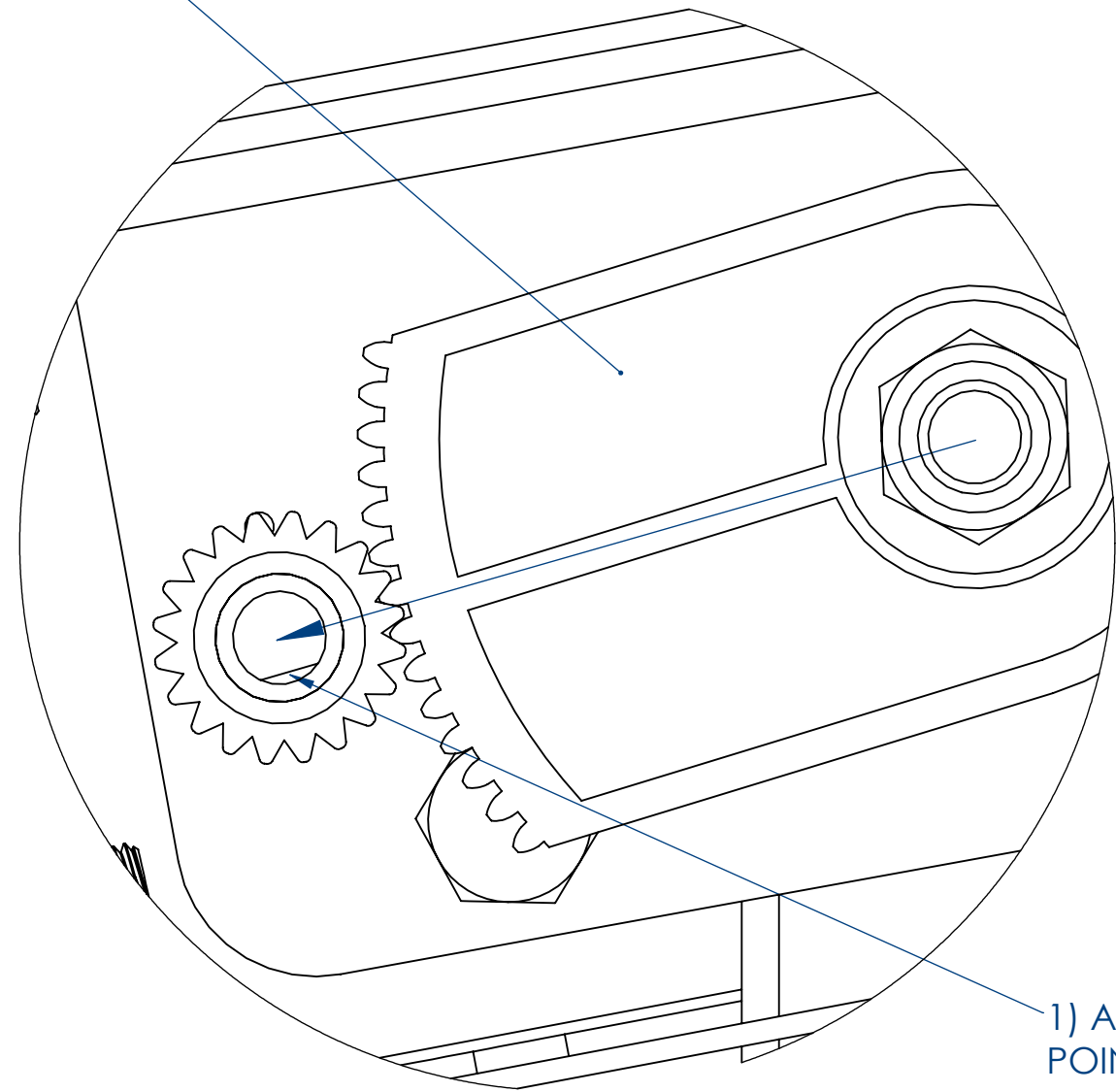

1) ALIGN FLAT ON POT SHAFT DOWNWARD AND POINTING TO THE CENTER OF THE SEGMENT GEAR

INSTALL ASSEMBLY WITH GEAR INSTALLED AND POT FLAT POINTING TO THE LEFT WHEN HANDLES ARE POINTED STRAIGHT FORWARD

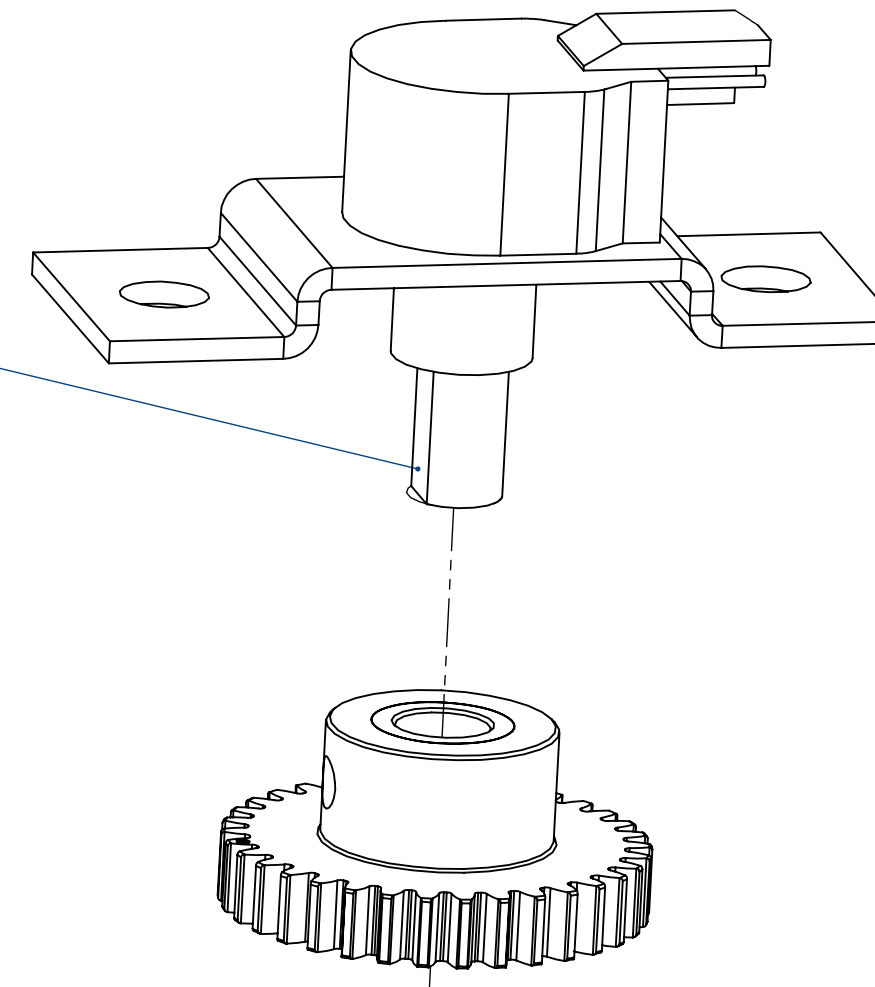

DETAIL B
SCALE 2 : 1

DETAIL A
SCALE 2 : 1

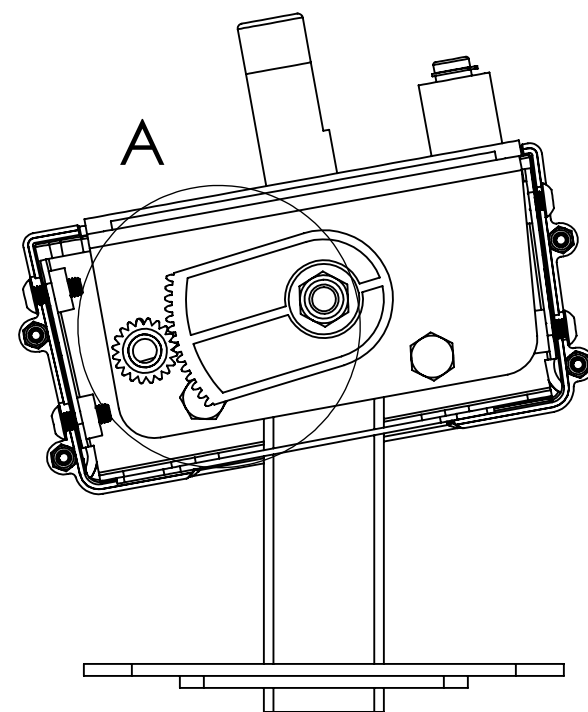

UP AND DOWN POT ALIGNMENT

MAKE SURE THAT THE HANDLES ARE POINTED STRAIGHT FORWARD DURING POT INSTALLATION

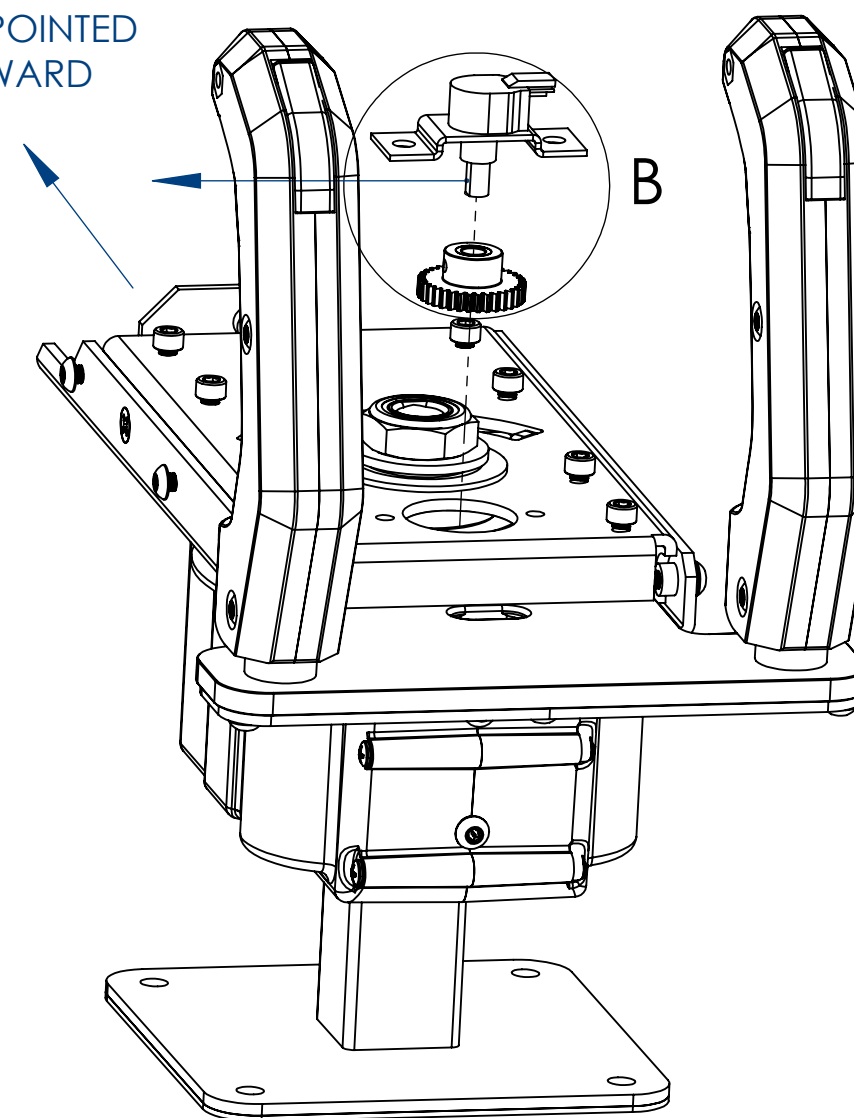

LEFT TO RIGHT POT ALIGNMENT

RAW THRILLS INC.	
TITLE: HALO GUN POT ALIGNMENT	
TOL: .X ±.030 .XX ±.015 .XXX ±.005	MATERIAL: SEE NOTES
HOLES: +.002/-0.000	FINISH: SEE NOTES
ANGLES: ±0.5°	PART NO.
SHEET 1 of 1	REV B

REV.	DESCRIPTION	DATE
A	RELEASED	11/17/15
B	CORRECTED PART NUMBERS	12/14/16
C	CORRECTED HAPP PART NUMBER ON ITEM #5	5/10/19
D	REMOVED ITEM 10	8/30/19

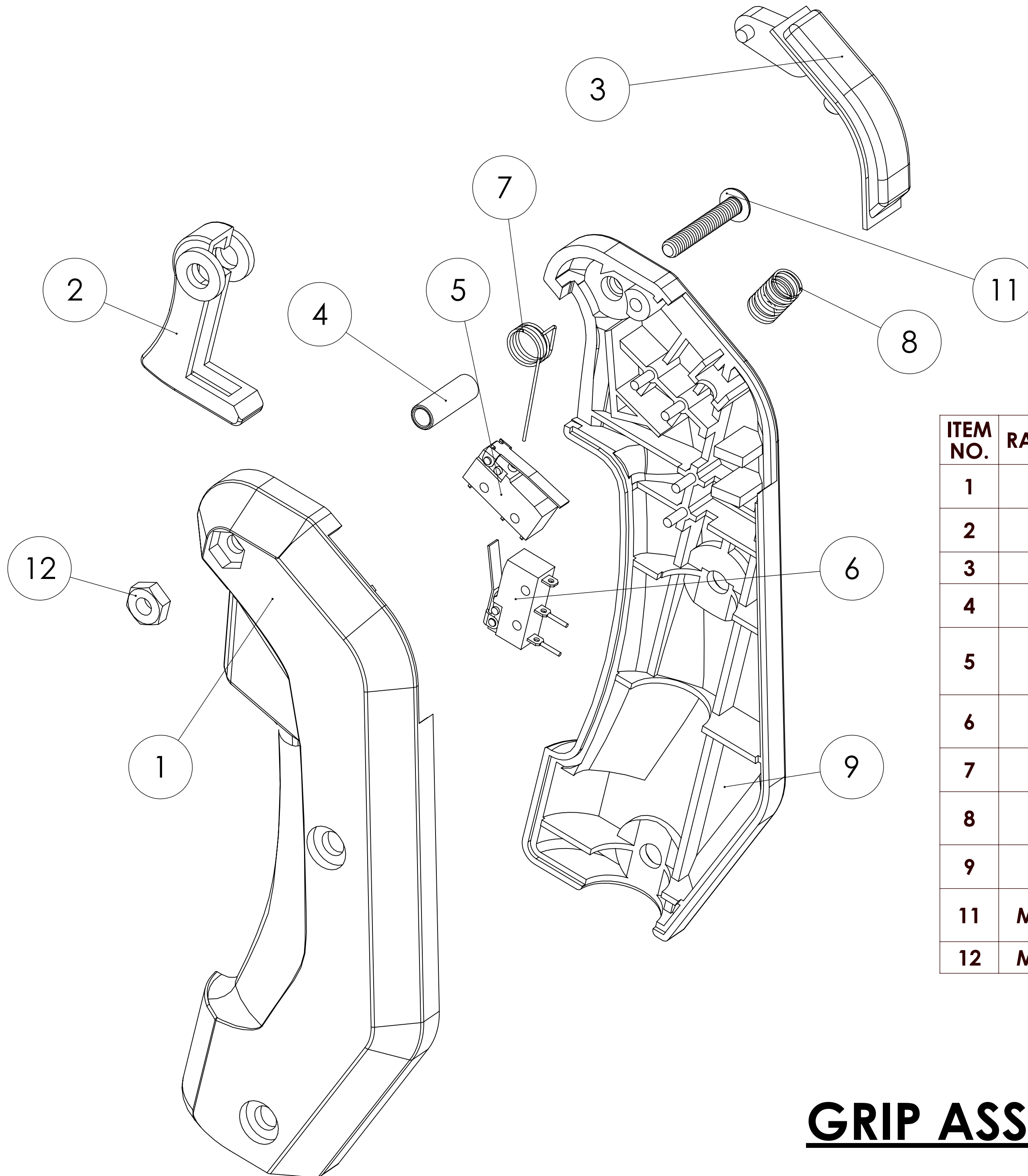

ITEM NO.	RAW PART NUMBER	HAPP NUMBER	DESCRIPTION	QTY.
1	608-00201-01	95-1294-00	GRIP, LEFT HALF	1
2	608-00204-01	95-1295-00	TRIGGER, RED	1
3	608-00203-01	95-1439-00	LARGE THUMB BUTTON	1
4	608-00205-01	95-1315-00	SHAFT, TRIGGER	1
5	608-00215-01	95-0259-ST	SWITCH ASSY FOR THUMB SWITCH	1
6	608-00220-01	95-0028-00	SWITCH ASSY. FOR TRIGGER	1
7	608-00206-01	95-1297-00	SPRING, TORSION	1
8	608-00207-01	95-1298-00	SPRING, COMPRESSION	1
9	608-00202-01	95-1293-00	GRIP, RIGHT HALF	1
11	MMC 96075A147	43-0378-00	SCREW, #8-32 x 1 TP BLACK	1
12	MMC 86537A140	43-1124-00	HEX NUT #8-32 BLACK	1

GRIP ASSEMBLY

RAW THRILLS INC.	
TITLE: JP GRIP ASSEMBLY	
TOL: .X ±.030 .XX ±.015 .XXX ±.005	MATERIAL:
HOLE: +.002/-0.000	FINISH: SEE NOTES
ANGLE: ±0.5°	PART NO.
SHEET 1 of 1	REV D

REV.	DESCRIPTION	DATE
A	RELEASED	1/8/24

ITEM NO.	PART NUMBER	DESCRIPTION	QTY
1	603-00755-01-G	GUN TOP VACFORM	1
2	R90-AP-7	GATLING LIGHT ASSEMBLY	1
3	R1-1071	COVER BRACKET	1
4	MMC 91251A595	5/16-18 X 3" SOCKET HEAD SCREW	1
5	MMC 92141A030	5/16" WASHER	1
6	MMC 90566A030	5/16-18 NYLOK NUT	1
7	MMC 96075A211	1/4-20 X .5" BLACK TAMPERPROOF SCREW	2
8	R90-13-31	UPPER LEFT DECAL	1
9	R90-13-32	UPPER RIGHT DECAL	1
10	R90-13-33	LOWER LEFT DECAL	1
11	R90-13-34	LOWER RIGHT DECAL	1
12	R90-13-35	SMALL LOWER LEFT DECAL	1
13	R90-13-36	SMALL LOWER RIGHT DECAL	1

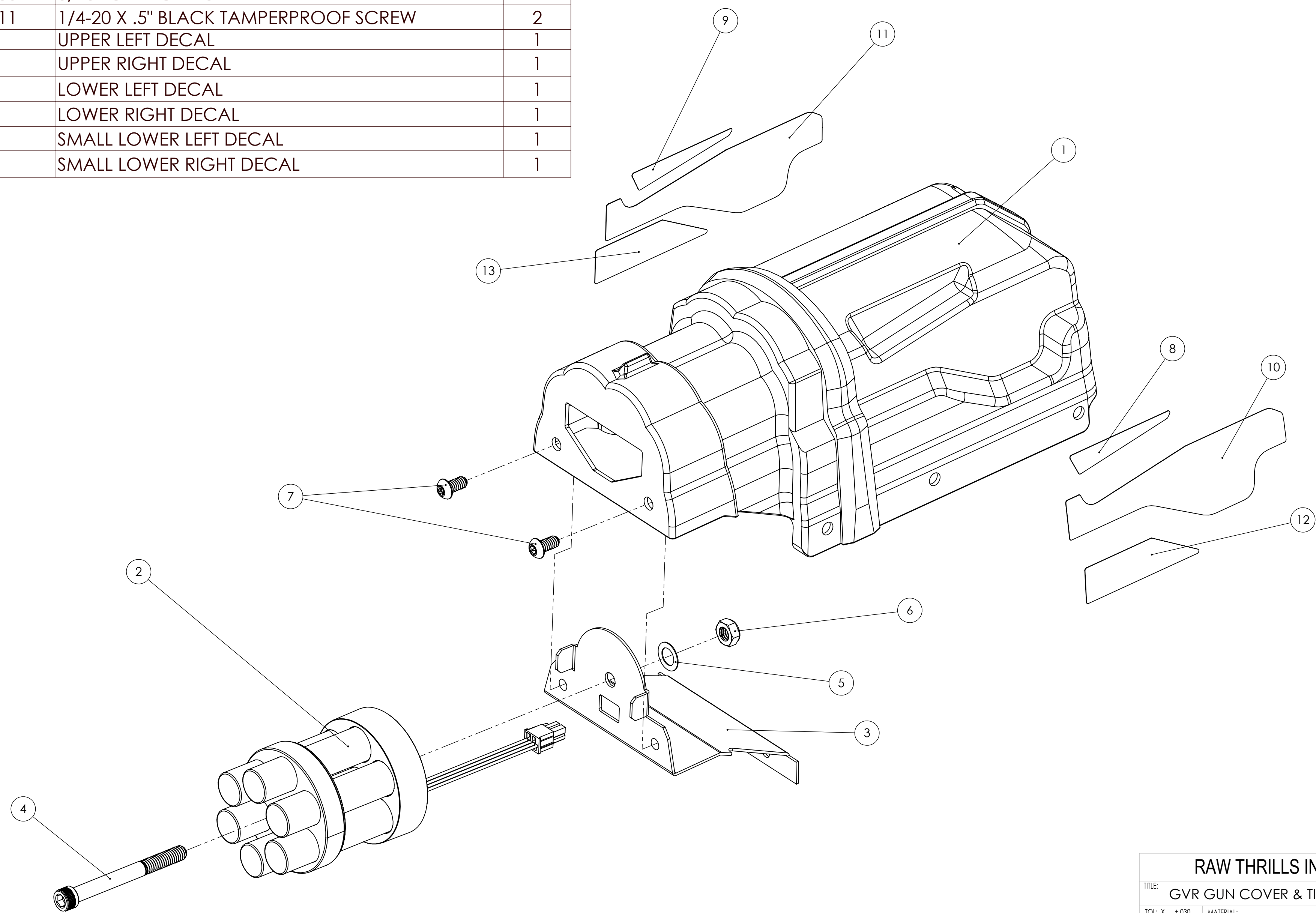

RAW THRILLS INC.	
TITLE: GVR GUN COVER & TIP ASSY	
TOL: .X ±.030 .XX ±.015 .XXX ±.005	MATERIAL: SEE NOTES
HOLES: +.002/-0.000	FINISH: SEE NOTES
ANGLES: ±0.5°	PART NO.
SHEET 1 of 1	REV A

SHEET 1: AC DISTRIBUTION + PCS + MONITORS + HEADSETS + COMPRESSOR

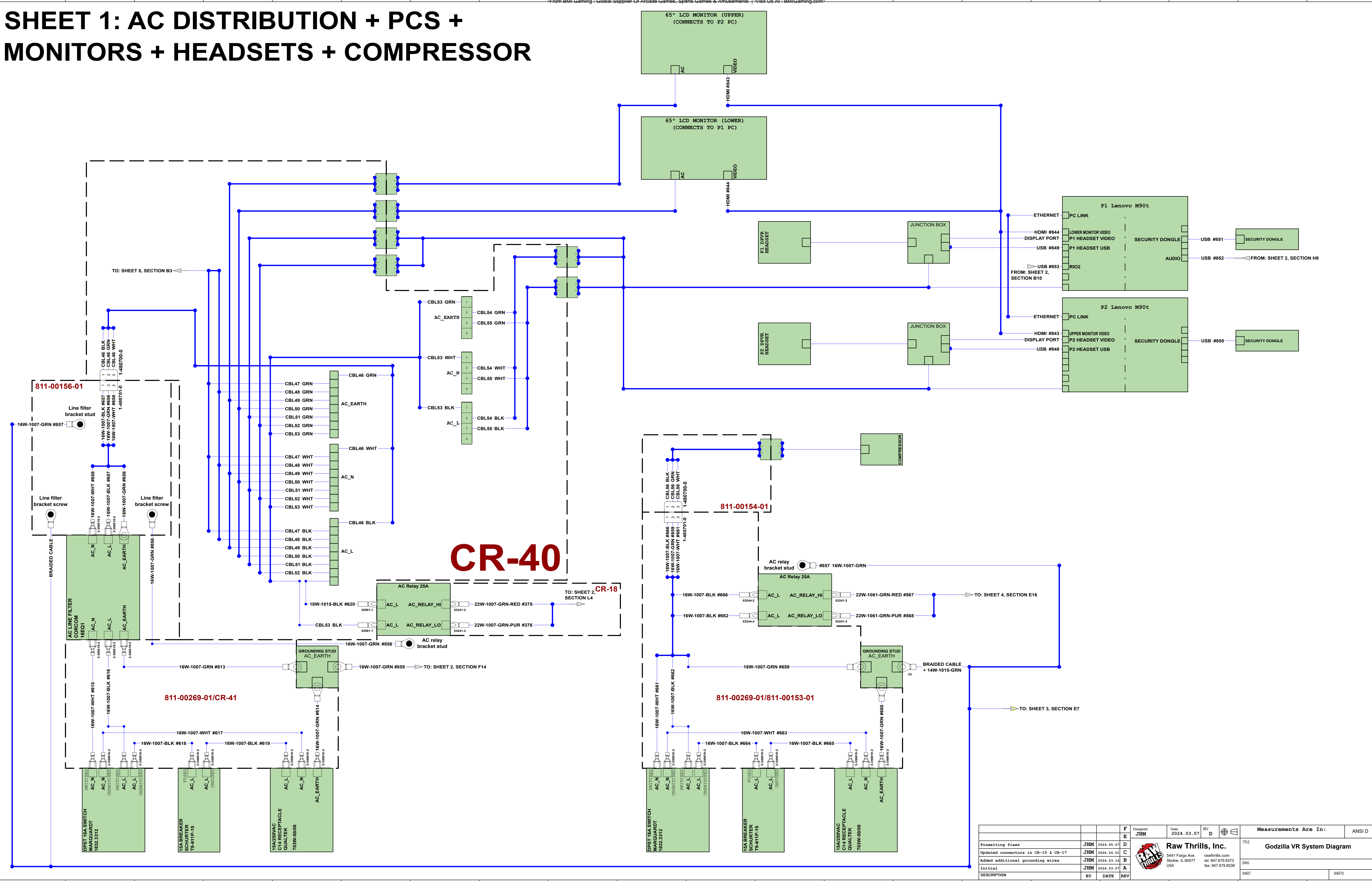

DESCRIPTION	BY	DATE	REV
Initial	JHM	2024.03.07	A
Added additional grounding wires	JHM	2024.03.14	B
Updated connectors in CR-15 & CR-17	JHM	2024.04.01	C
Formatting fixes	JHM	2024.05.07	D

Designated: JHM Date: 2024.03.07 REV: D	Measurements Are In: ANSI D
Raw Thrills, Inc. 5441 Fargo Ave. Skokie, IL 60077 USA rawthrills.com tel: 847.678.8373 fax: 847.678.8538	TITLE: Godzilla VR System Diagram DWG SHEET

SHEET 2: MAIN HARNESS + IO & AUDIO PCBS

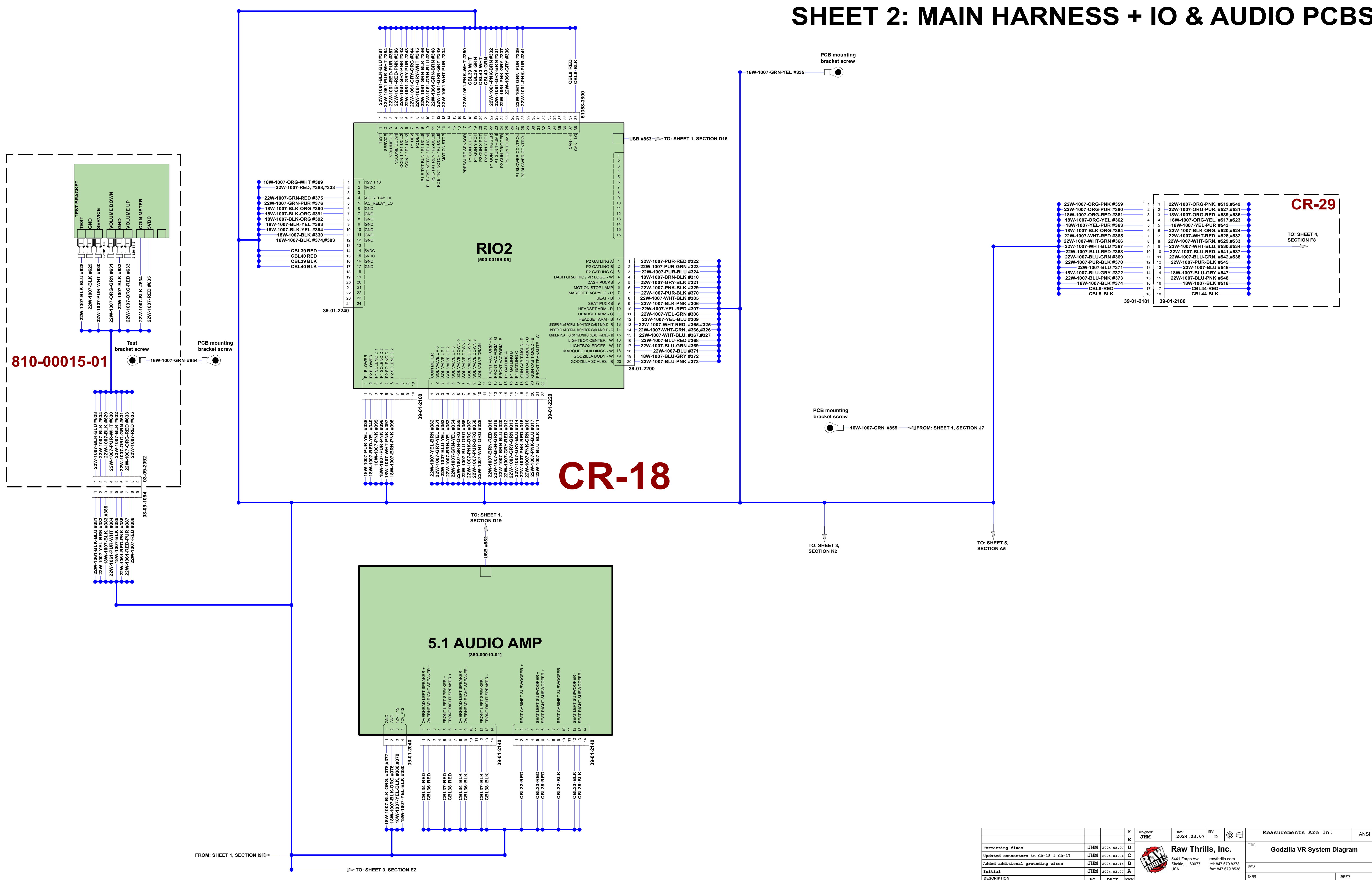

810-00015-01

CR-18

CR-29

DESIGNED	JHM	DATE	2024.03.07	REV	D	MEASUREMENTS ARE IN:	ANSI D
FORMATTING FIXES	JHM	2024.05.07				TITLE	Godzilla VR System Diagram
UPDATED CONNECTORS IN CR-15 & CR-17	JHM	2024.04.01				DWG	
ADDED ADDITIONAL GROUNDING WIRES	JHM	2024.03.14				SHEET	
INITIAL	JHM	2024.03.07					
DESCRIPTION	BY	DATE	REV				

Raw Thrills, Inc.
 5411 Fargo Ave., Skokie, IL 60077, USA
 rawthrills.com
 tel: 847.679.8373
 fax: 847.679.8538

SHEET 3: SPACER CABINET + COMPRESSOR COMPARTMENT

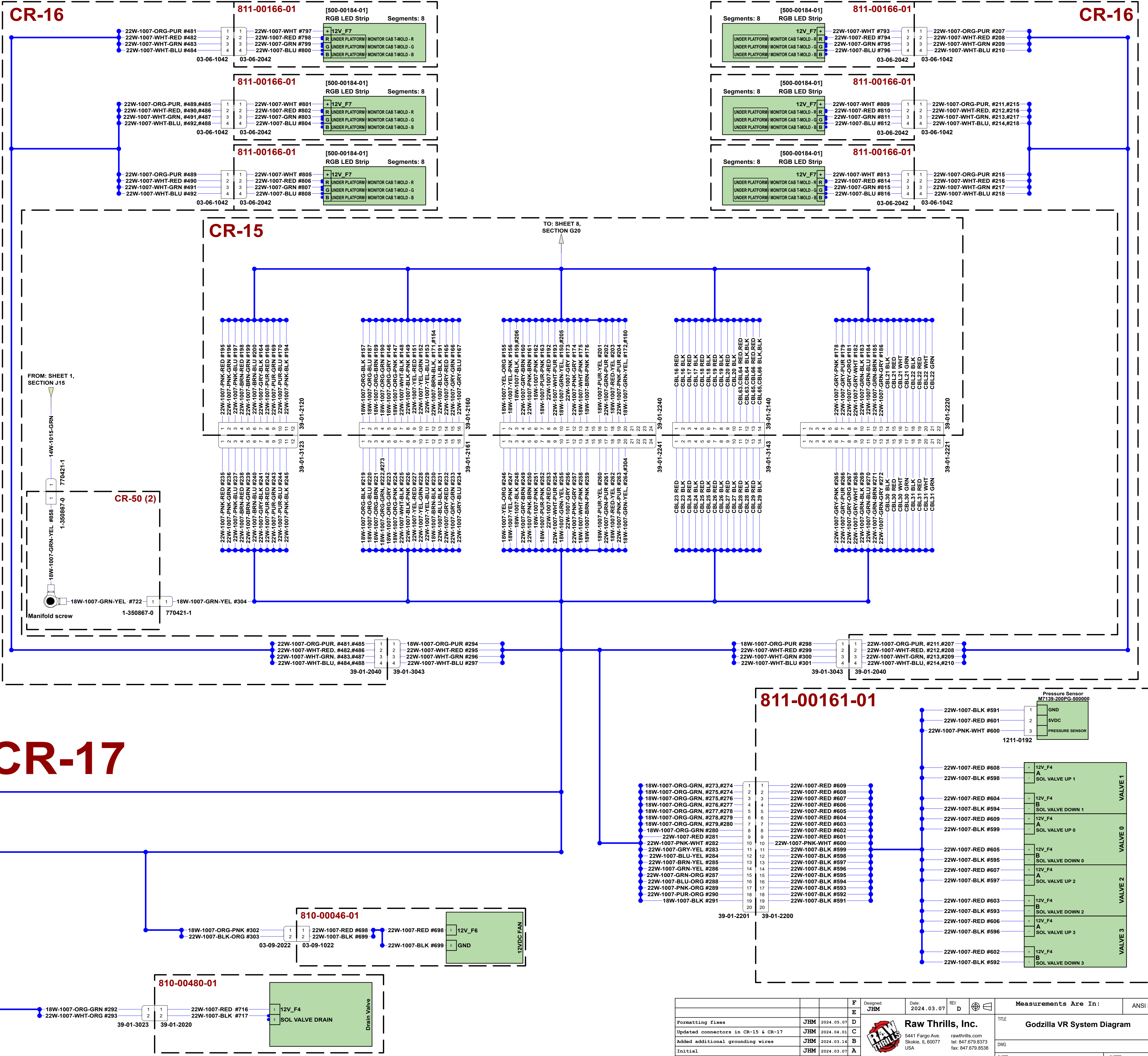

DESCRIPTION	BY	DATE	REV	REV
Formatting fixes	JHM	2024.05.07	D	
Updated connectors in CR-15 & CR-17	JHM	2024.04.01	C	
Added additional grounding wires	JHM	2024.03.14	B	
Initial	JHM	2024.03.07	A	

DESIGNER	DATE	REV	REV
JHM	2024.03.07	D	

Measurements Are In: ANSI D

Raw Thrills, Inc.
4411 Fargo Ave.
Skokie, IL 60077
USA
rwt@rawthrills.com
tel: 847.679.8373
fax: 847.679.8538

TITLE: **Godzilla VR System Diagram**

DWG SHEET

SHEET 4: COMPRESSOR MONITOR PCB + MAIN CABINET UPPER COMPARTMENT

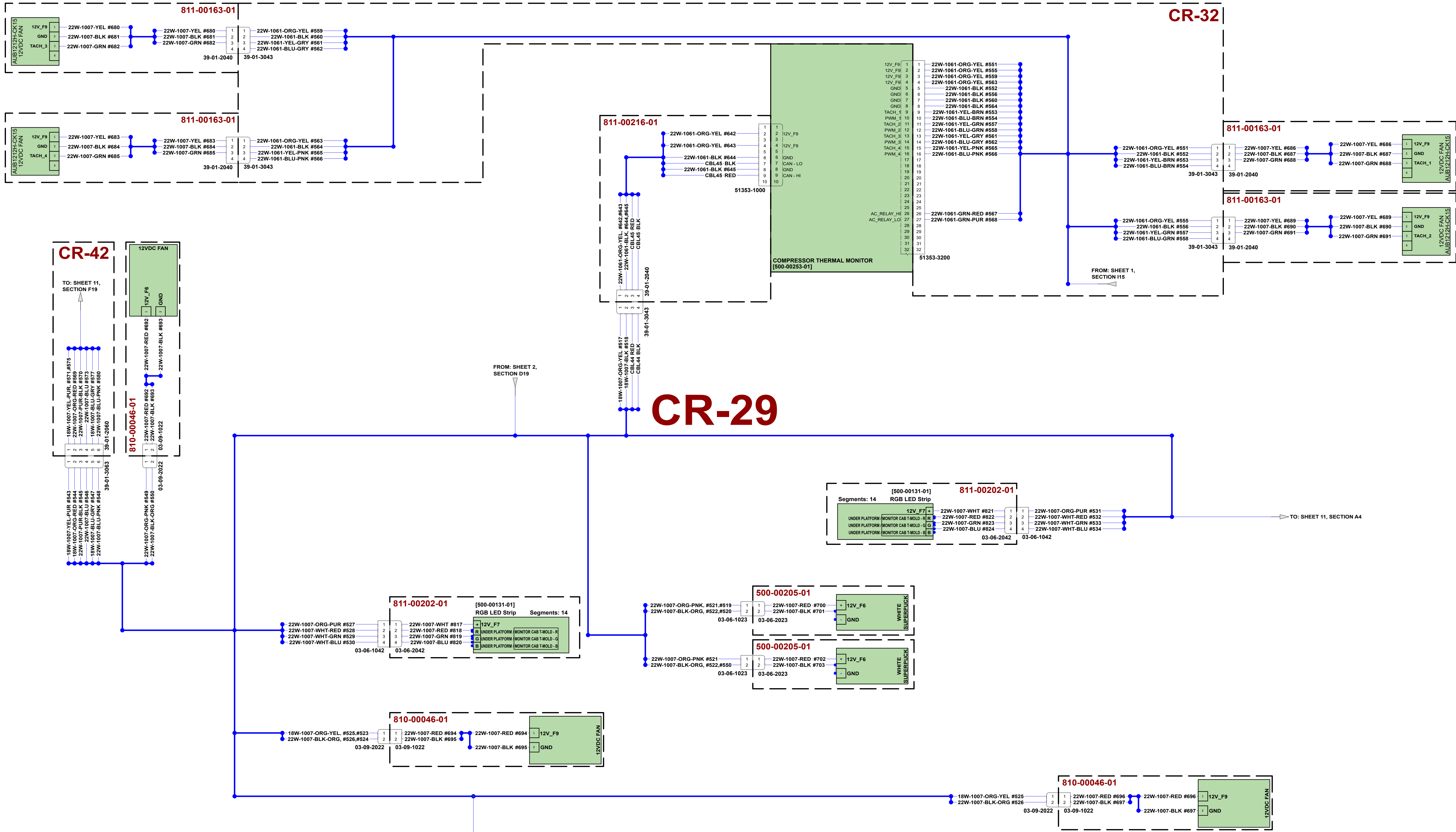

Designed: JHM	Date: 2024.03.07	REV: D	Measurements Are In: ANSI D
Formatted files	JHM 2024.05.07	D	Raw Thrills, Inc. 5411 Fargo Ave. Skokie, IL 60077 USA rawthrills.com tel: 847.678.8373 fax: 847.679.8538
Updated connectors in CR-15 & CR-17	JHM 2024.04.01	C	
Added additional grounding wires	JHM 2024.03.14	B	
Initial	JHM 2024.03.07	A	
DESCRIPTION	BY: JHM	DATE: 2024.03.07	
TITLE: Godzilla VR System Diagram SHEET: _____ OF _____ SHEETS			

SHEET 5: DC DISTRIBUTION

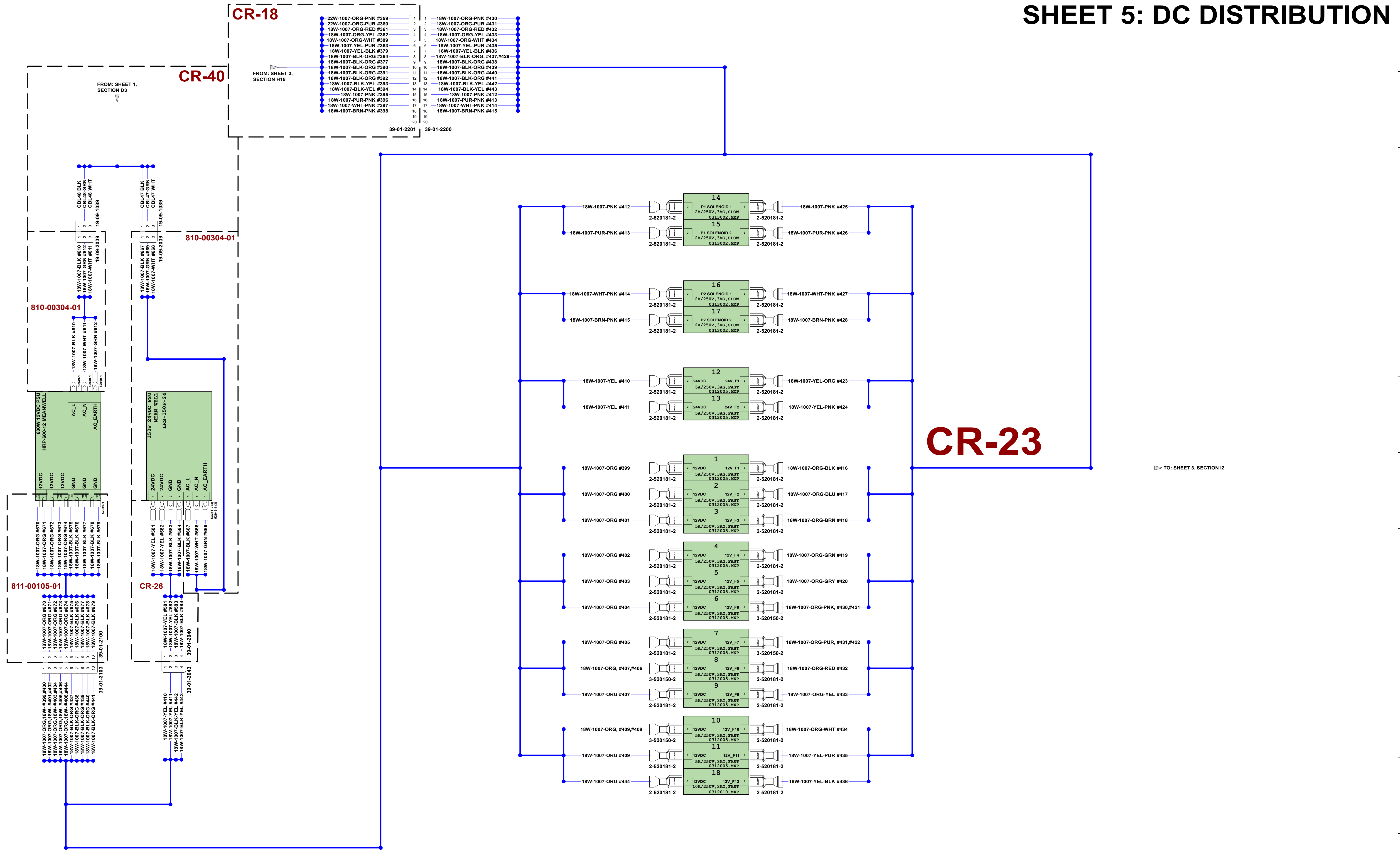

CR-23

CR-18

CR-40

810-00304-01

810-00304-01

811-00105-01

CR-26

DESIGNED	JHM	DATE	2024.03.07	REV	D	MEASUREMENTS ARE IN:	ANSI D
FORMATTING FIXES	JHM	DATE	2024.05.07				
UPDATED CONNECTORS IN CR-15 & CR-17	JHM	DATE	2024.04.01				
ADDED ADDITIONAL GROUNDING WIRES	JHM	DATE	2024.03.14				
INITIAL	JHM	DATE	2024.03.07				
DESCRIPTION	BY	DATE	REV				



Raw Thrills, Inc.
 5411 Fargo Ave. | rawthrills.com
 Skokie, IL 60077 | tel: 847.678.8373
 USA | fax: 847.679.8538

TITLE: **Godzilla VR System Diagram**

DWG

SHEET

SHEETS

SHEET 7A: P1 SEAT + P1 HEADSET ARM

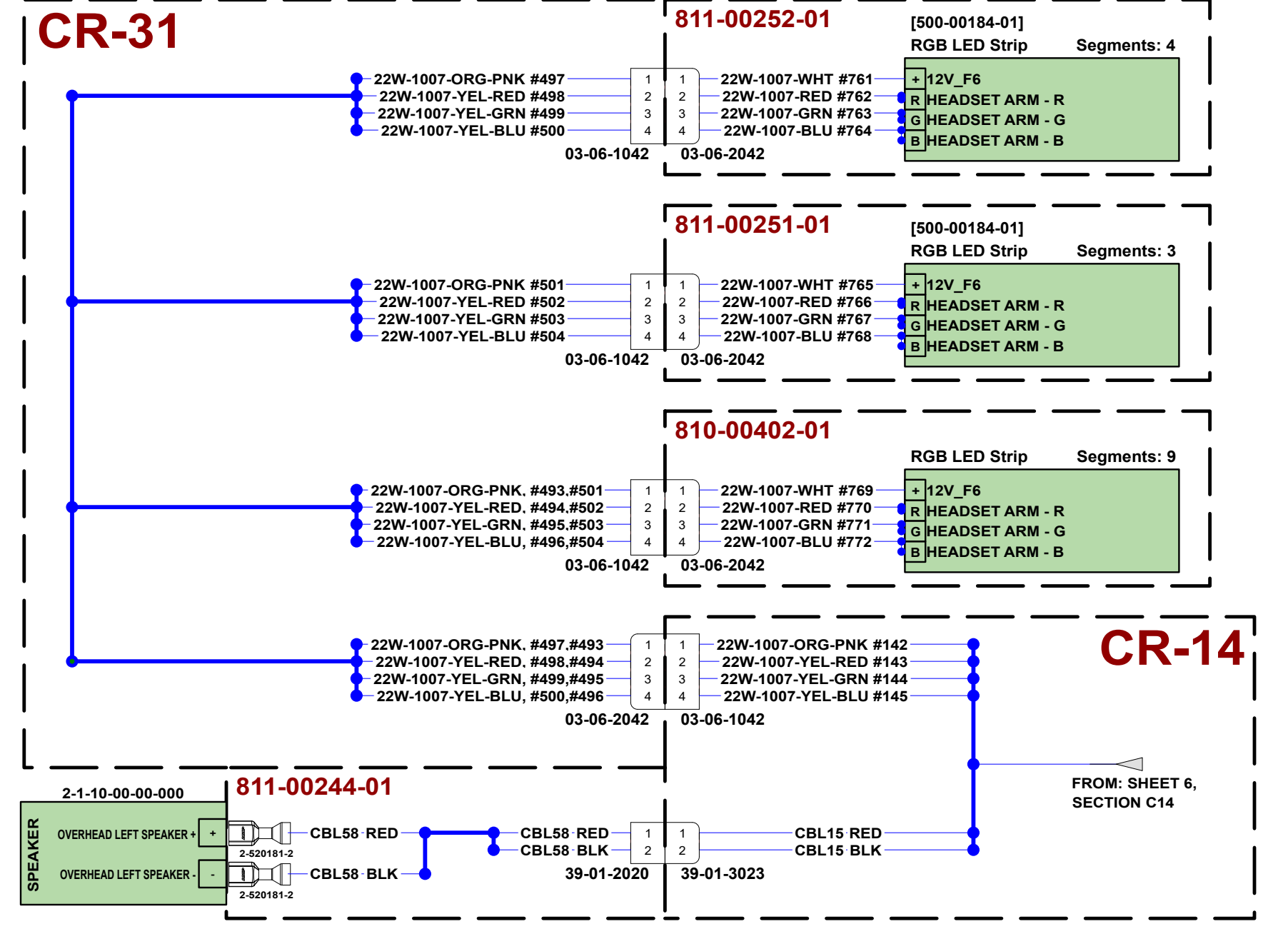
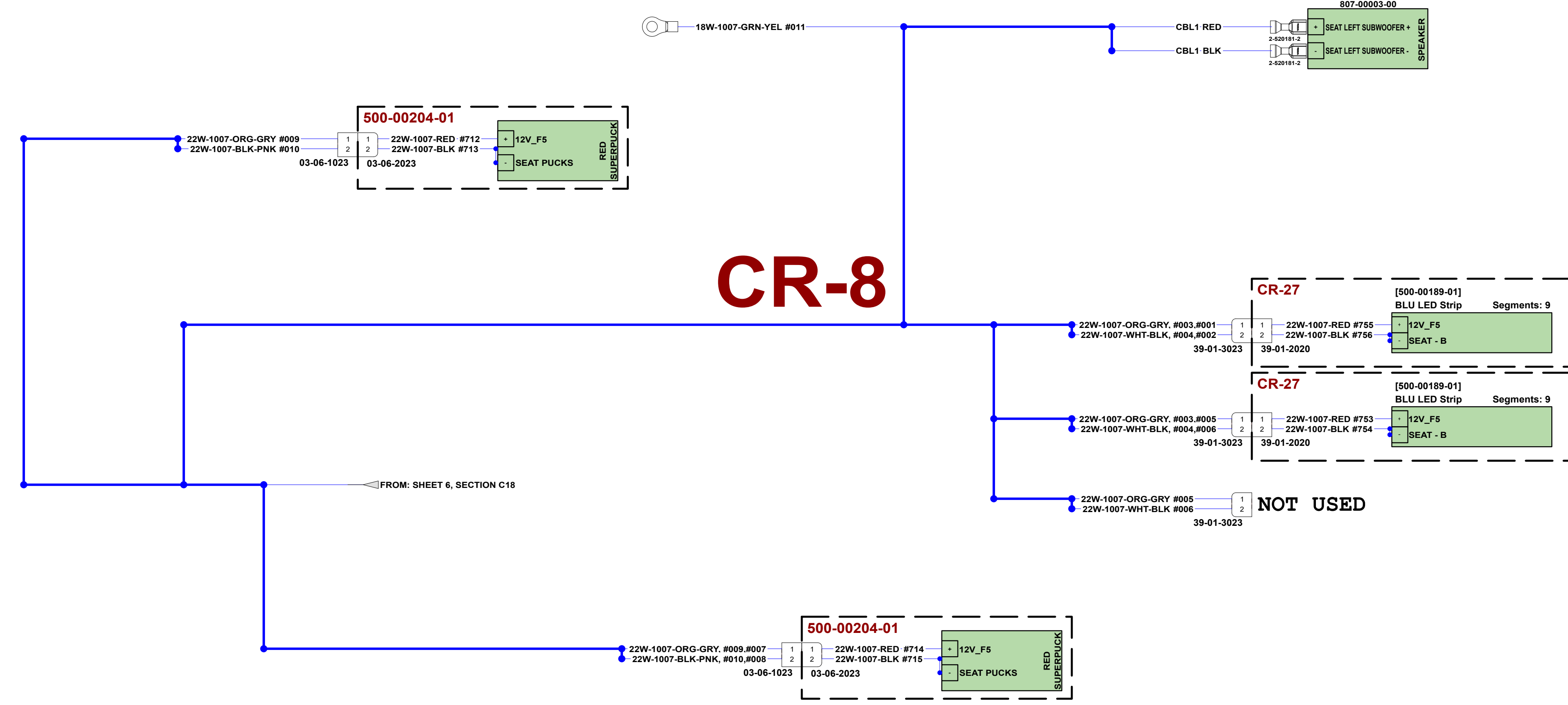

SHEET 7B: P2 SEAT + P2 HEADSET ARM

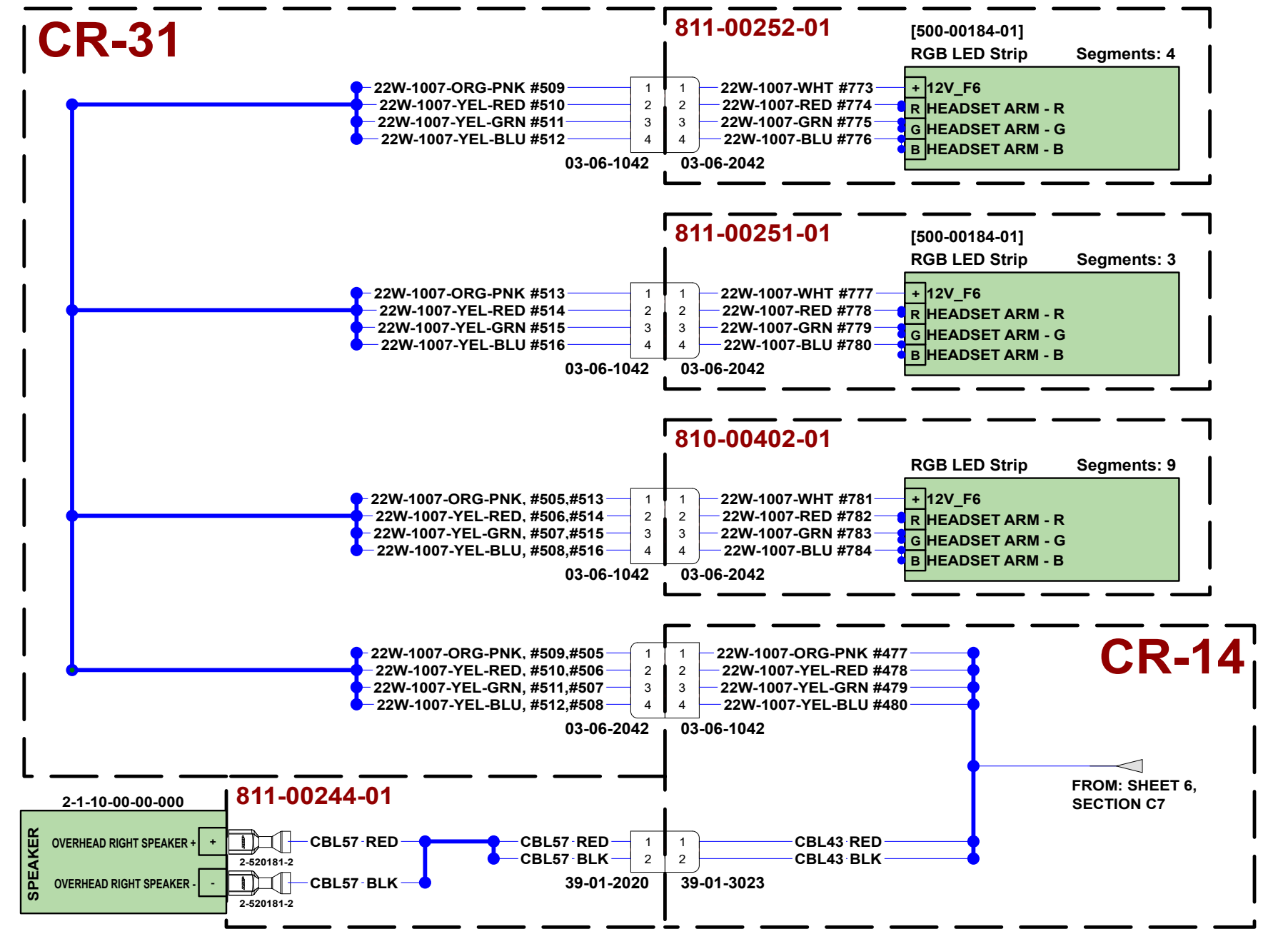
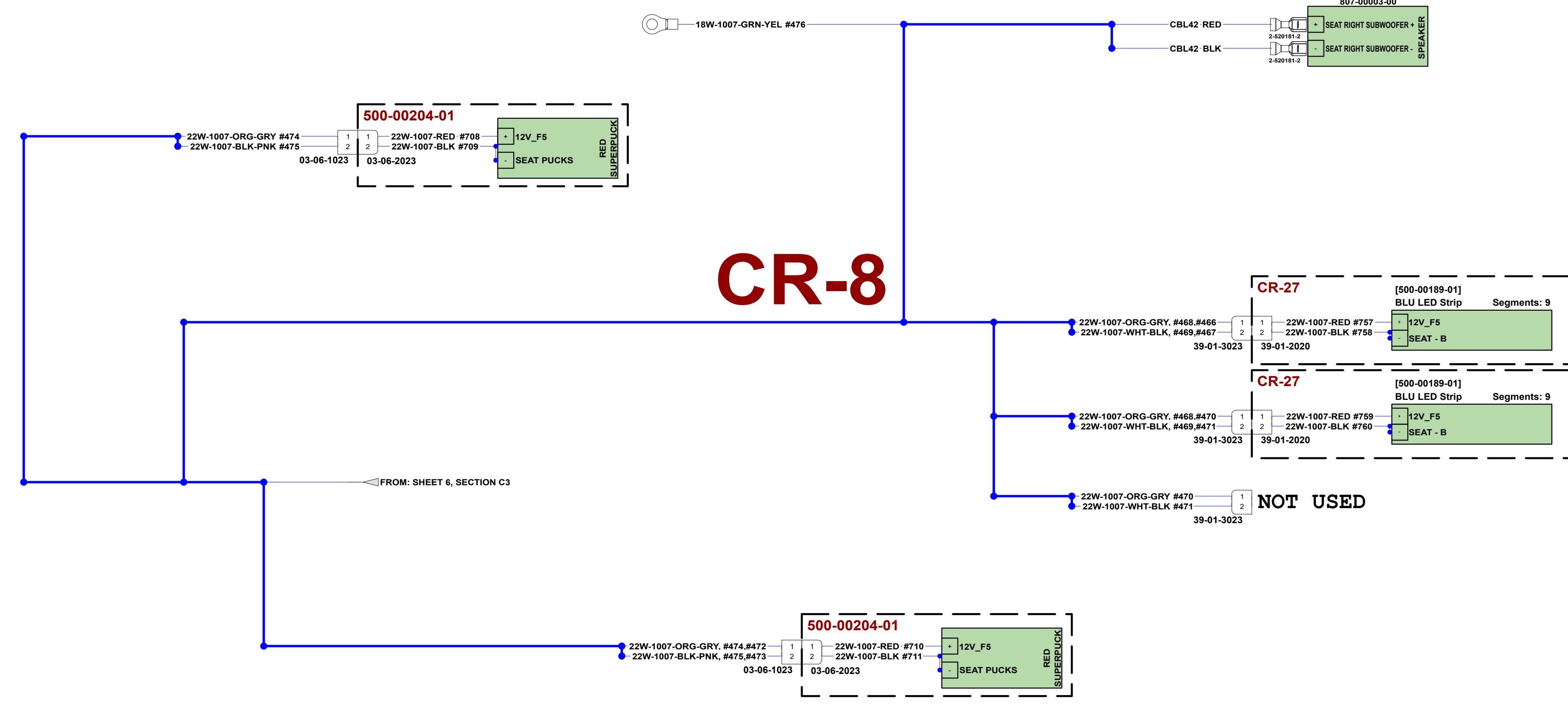

DESIGNER	JHM	DATE	2024.03.07	REV	D	MEASUREMENTS ARE IN:	ANSI D
FORMATTING FIXES	JHM	2024.05.07				TITLE	Godzilla VR System Diagram
UPDATED CONNECTORS IN CR-15 & CR-17	JHM	2024.04.01				DWG	
ADDED ADDITIONAL GROUNDING WIRES	JHM	2024.03.14				SHEET	
INITIAL	JHM	2024.03.07					
DESCRIPTION	BY	DATE	REV				



SHEET 8: VAULT

810-00008-01

CR-15

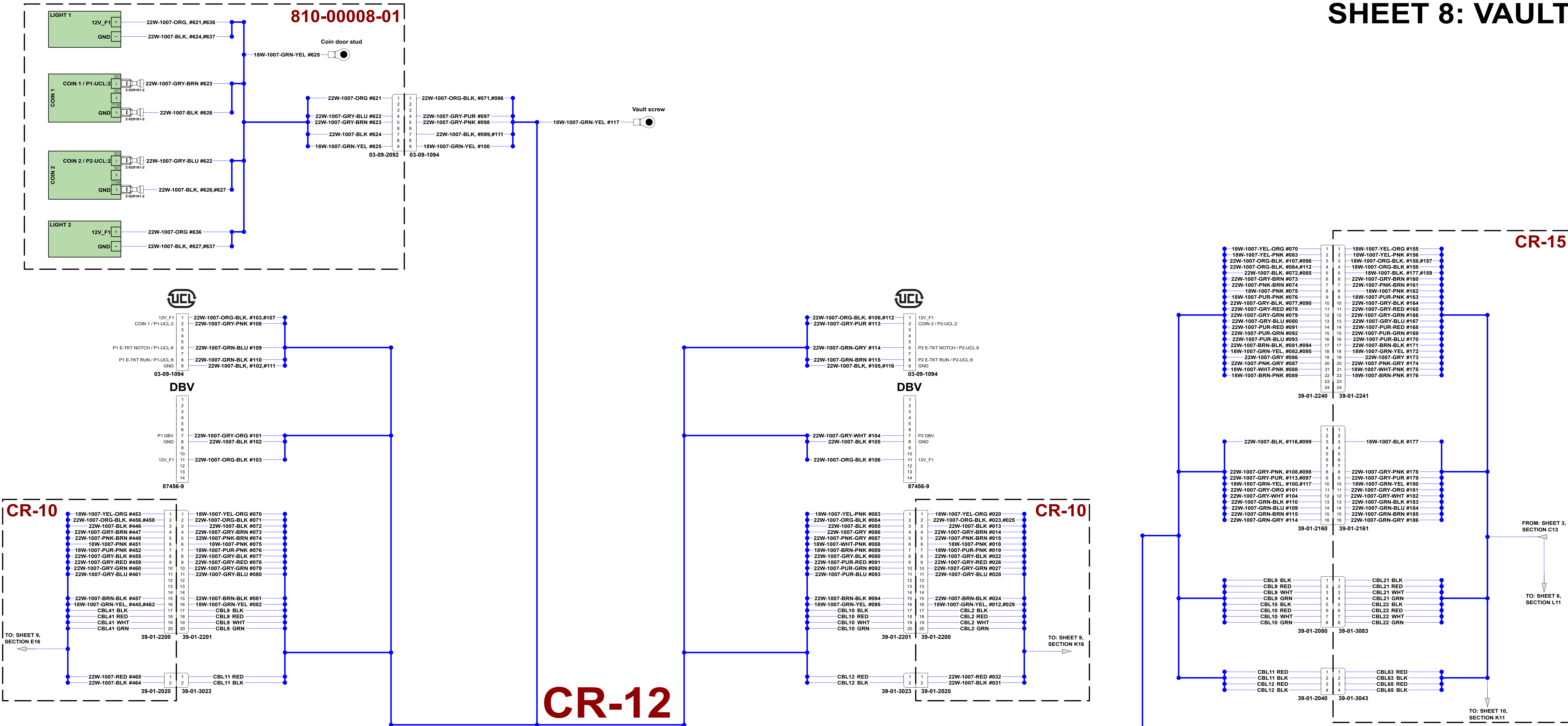

DESIGNED	JHM	DATE	2024.03.07	REV	D	MEASUREMENTS ARE IN:	ANSI D
FORMATTING FIXES	JHM	DATE	2024.05.07	REV	D	TITLE	Godzilla VR System Diagram
UPDATED CONNECTORS IN CR-15 & CR-17	JHM	DATE	2024.04.01	REV	C	DWG	
ADDED ADDITIONAL GROUNDING WIRES	JHM	DATE	2024.03.14	REV	B	SHEET	
INITIAL	JHM	DATE	2024.03.07	REV	A	SHEETS	
DESCRIPTION	BY	DATE	REV				

Raw Thrills, Inc.
 5411 Fargo Ave. Skokie, IL 60077
 rawthrills.com
 tel: 847.678.6373
 fax: 847.678.6538
 USA

SHEET 9A: P1 CONTROL PANEL

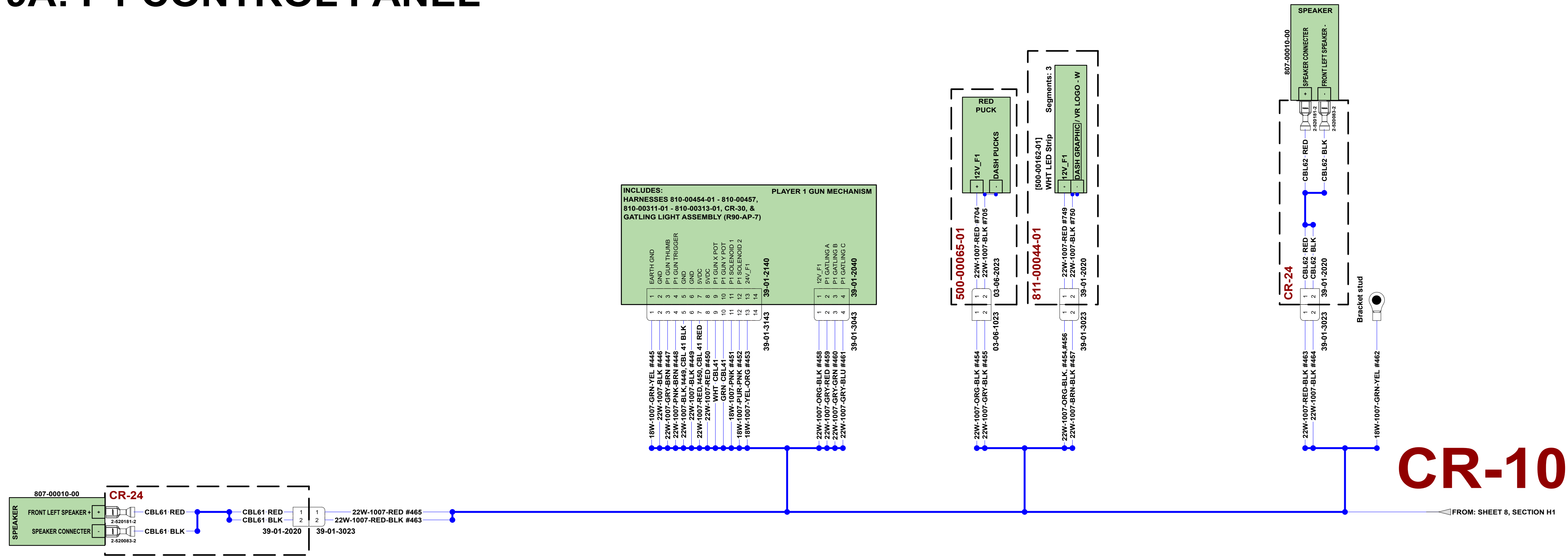

SHEET 9B: P2 CONTROL PANEL

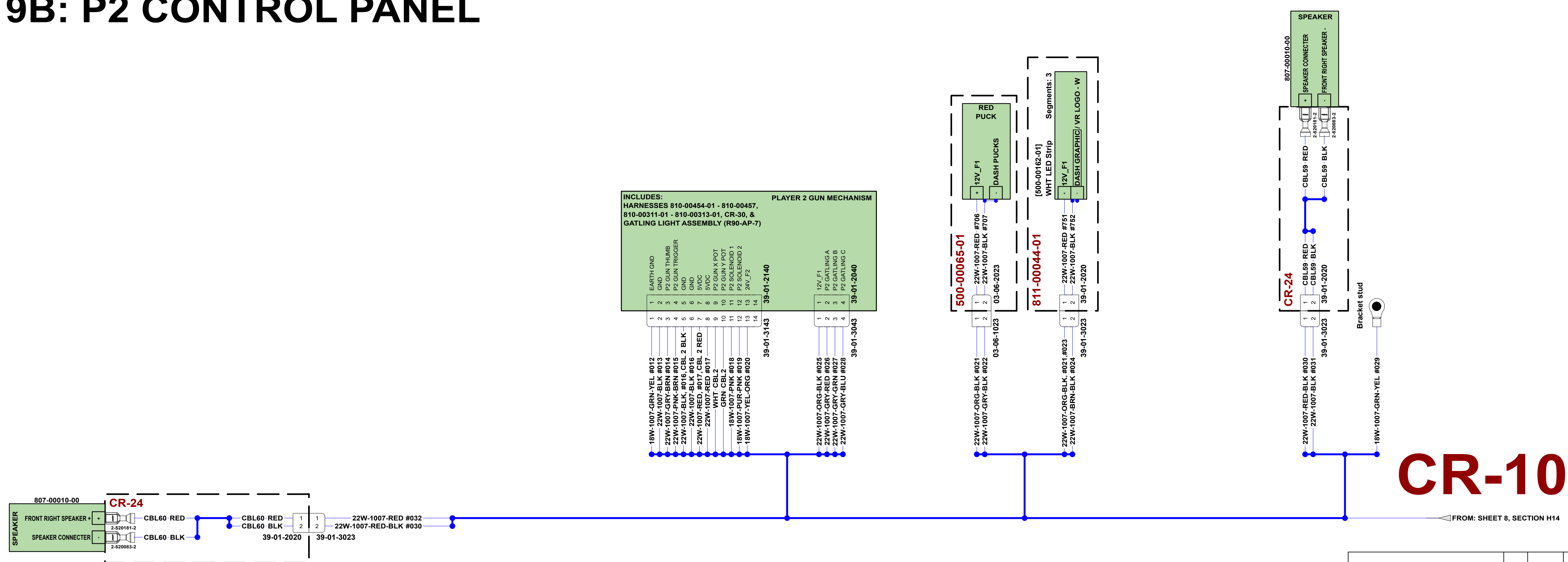

DESIGNED	JHM	DATE	2024.03.07	REV	D	MEASUREMENTS ARE IN:	ANSI D
FORMATTING FIXES	JHM	DATE	2024.05.07				
UPDATED CONNECTORS IN CR-15 & CR-17	JHM	DATE	2024.04.01				
ADDED ADDITIONAL GROUNDING WIRES	JHM	DATE	2024.03.14				
INITIAL	JHM	DATE	2024.03.07				
DESCRIPTION		BY		DATE	REV		

Raw Thrills, Inc.

5441 Fargo Ave. | rawthrills.com
 Skokie, IL 60077 | tel: 847.678.8373
 USA | fax: 847.678.8538

TITLE	Godzilla VR System Diagram	
DWG		
SHEET		SHEETS

SHEET 10: CONTROL CABINET FRONT

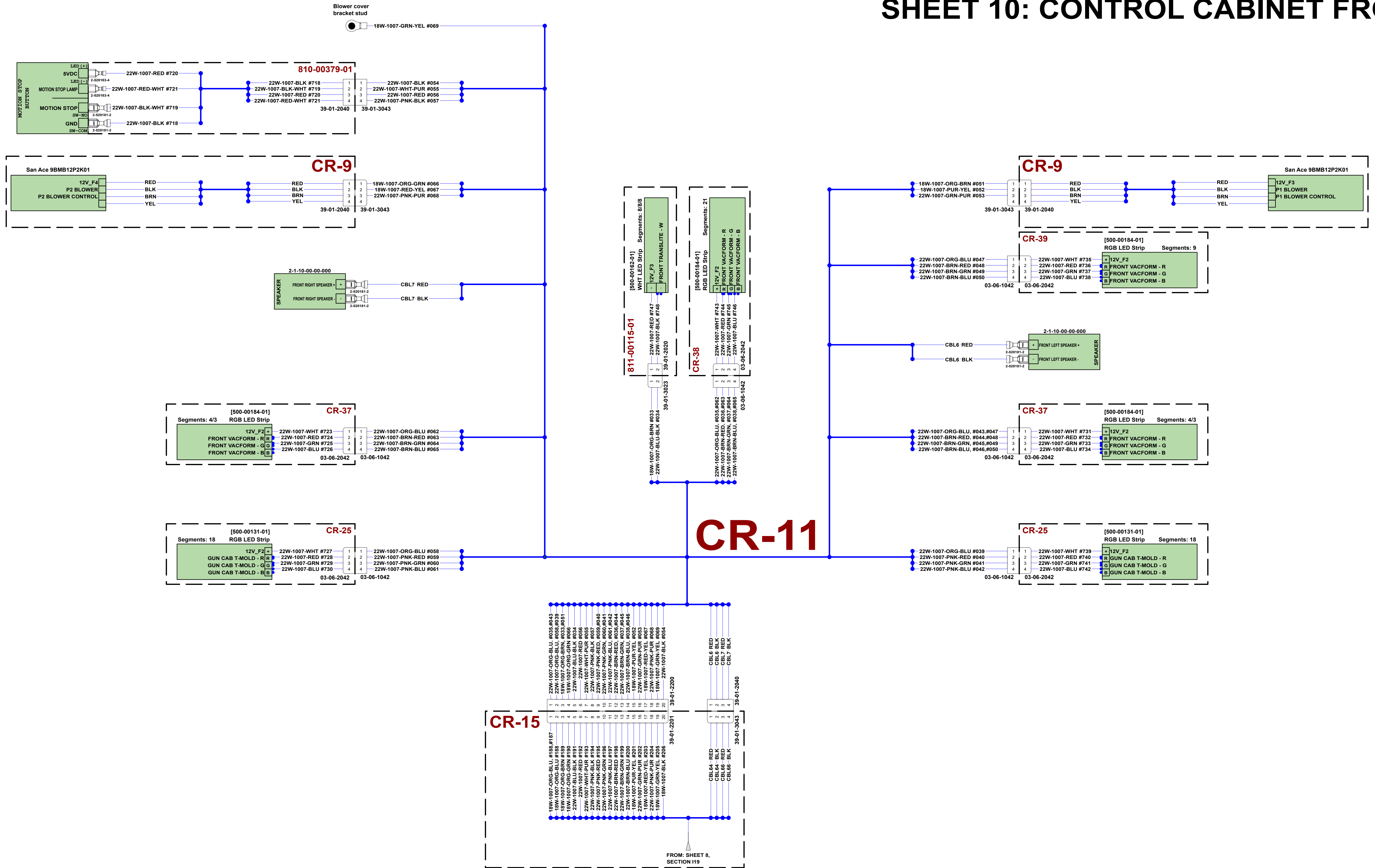

F		Designed:	JHM	Date:	2024.03.07	REV	D	Measurements Are In:	ANSI D
E		Formatted files	JHM	2024.05.07				Raw Thrills, Inc.	
D		Updated connectors in CR-15 & CR-17	JHM	2024.04.01				4411 Fargo Ave. Skokie, IL 60077 USA	
C		Added additional grounding wires	JHM	2024.03.14				rawthrills.com tel: 847.679.8373 fax: 847.679.8538	
B		Initial	JHM	2024.03.07				TITLE: Godzilla VR System Diagram	
A		DESCRIPTION	BY	DATE	REV			DWG SHEET SHEETS	

SHEET 11: MARQUEE + SIDE PANEL LIGHT BOXES

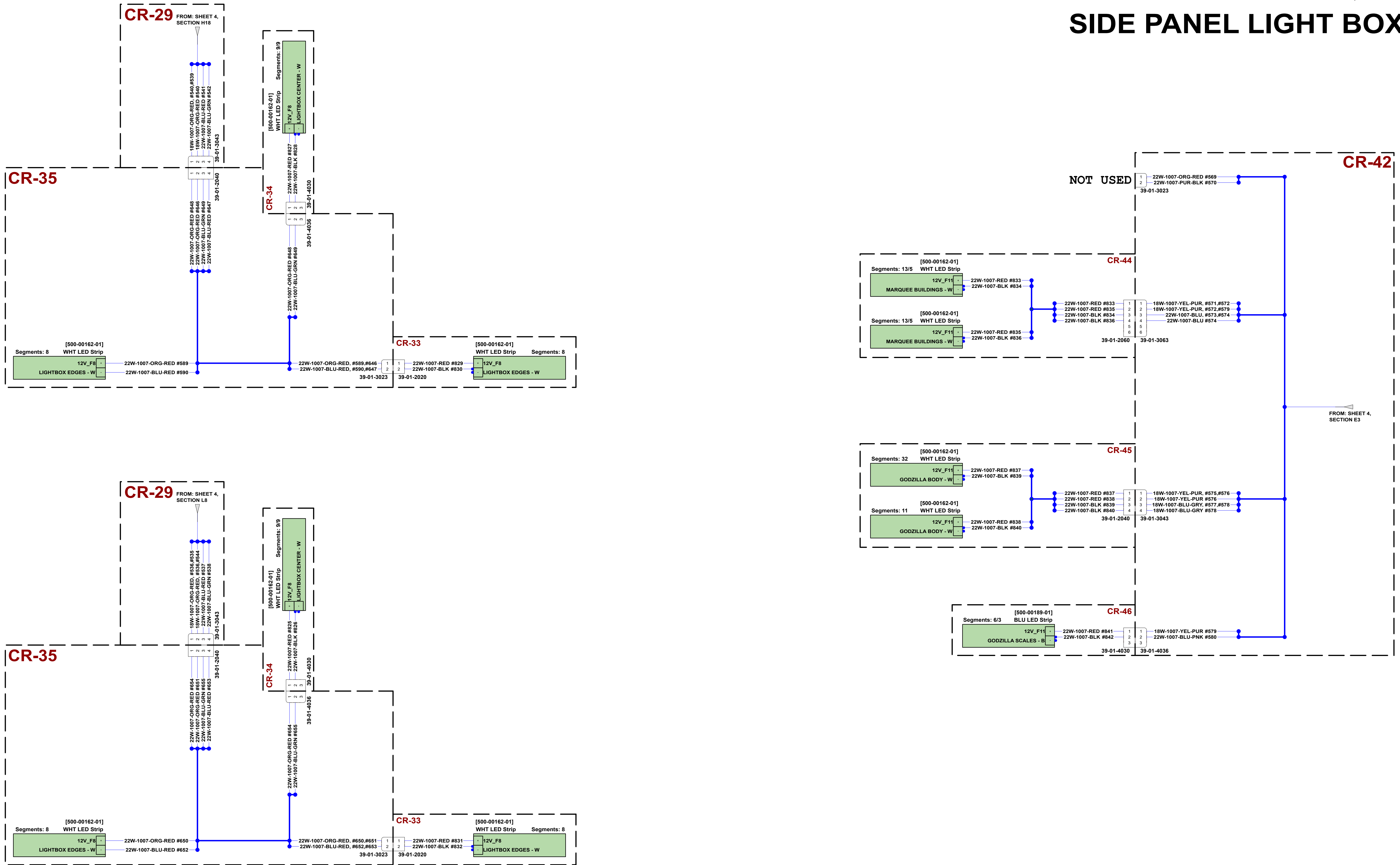

F		Designed:	JHM	Date:	2024.03.07	REV	D	Measurements Are In:	ANSI D
E		Raw Thrills, Inc.							
D		4411 Fargo Ave. Skokie, IL 60077 USA							
C		rawthrills.com tel: 847.678.8373 fax: 847.678.8538							
B		TITLE: Godzilla VR System Diagram							
A		DWG							
BY		DATE							
REV		DESCRIPTION							