

Injustice Arcade™

Operator's Manual



INJUSTICE: GODS AMONG US and all related characters and elements © & TM DC Comics and Warner Bros. Entertainment Inc. (s17) ©2017 Raw Thrills, Inc. All Rights Reserved
Unreal® Engine, ©1998 – 2017, Epic Games, Inc. All rights reserved
Unreal® is a trademark or registered trademark of Epic Games, Inc. in the United States of America and elsewhere
Uses Bink Video. Copyright (C) 1997-2017 by RAD Game Tools, Inc

For an explanation of optimal operating practices, watch the video below:

Click link (if on computer/mobile device):

<https://youtu.be/v05ZZ-i2zzE>

or scan code below:



Table of Contents

Safety	6
Operation	6
Transporting.....	6
Handling Components	6
Disconnect Power.....	6
Grounding	6
Electrical Shocks.....	6
Monitor	6
Power Selector.....	6
Power Cord	6
Surge Suppressor	7
Water and Other Liquid Sources	7
Connectors	7
Computer	7
Tempered Glass Warning	7
Hazard to Epileptics	7
Manual.....	7
Specifications.....	7
Product Specifications	8
Electrical Power	8
Dimensions	8
Operating Temperature.....	8
Operating Humidity	8
Fuse Replacement Guide	8
RIO	8
Game Lighting	8
Setup	9
Unpack Materials.....	9
43" Cabinet Assembly	10
55" Cabinet Assembly	11
Check Electrical Settings	12

- Startup Game..... 12
- Diagnostics and Adjustments..... 13
 - Service Panel..... 13
 - Basic Functional Test on Initial Power Up..... 13
 - Test Menu Navigation..... 14
 - Test Menus 14
 - Main Menu..... 14
- Cards and Card Dispensers 19
 - Refilling Card Dispensers 19
 - Clearing Card Dispenser Jam..... 19
 - Authorizing More Cards..... 20
- PC Hardware 21
 - HP Elitedesk 705 G3 MT BIOS 22
 - PC Hard Drive Recovery 23
- Troubleshooting..... 24
- Technical Support 29
- Electrical and Mechanical Illustrations 30

Safety

Operation

Before operating game, read this manual. Failure to properly install and operate this game could result in malfunction or accident. Operate the game in accordance with the manual.

Transporting

The cabinet is very heavy. Because the monitor is high, the cabinet is also very top-heavy. Use appropriate care when moving or transporting cabinet. It contains fragile glass and electronic components. Avoid rough handling.

Handling Components

Many components are extremely sensitive to handling, environmental and Electrostatic Discharge (ESD) events—especially the computer. Do not handle it roughly. Before servicing, call your distributor and inquire about the PC warranty. Use proper ESD procedures when servicing. Protect components from harmful environmental conditions, such as extreme temperatures, excessive moisture or other damaging effects.

Disconnect Power

Always turn the power off and unplug the unit before servicing or making adjustments unless otherwise instructed. Installing or repairing components while power is on can damage the components and void the warranty.

Grounding

Avoid electrical shock. Do not plug in AC power until you have inspected and properly grounded the unit. Only plug into a grounded, three-wire outlet. Do not use a “cheater” plug or cut off the ground pin on the line cord.

Electrical Shocks

There is no isolation transformer in the cabinet. Disconnect AC power before servicing. However, be aware that lethal voltages can remain in the electronic components even when AC power is disconnected. Use extreme caution when servicing. Verify that there is a working ground connection. If the unit sustains water damage, cease using it immediately and unplug AC power.

Monitor

The monitor contains no user serviceable parts. Do not attempt to service the monitor.

Power Selector

Before installing game, ensure the voltage on the PC and power supply is set properly. There is a 115/230 VAC selector switch that must be set for the correct voltage for your site. The setting must match the line voltage at the installation site.

Power Cord

If the power cord is damaged or lost, replace it with an identical cord as supplied by the manufacturer or an authorized service agent.

Surge Suppressor

It is recommended that you plug your game's power cord into a surge suppressor to help protect from power surges that may damage sensitive electronic components.

Water and Other Liquid Sources

Do not install game near sprinkler or other water jet sources. Do not use water jet to clean game. Keep minimum clearance behind game and wall for proper ventilation but also prevent access of liquid from spills and sprays from entering ventilation holes.

Connectors

When servicing machine, ensure all connectors mate properly. If connectors do not slip in easily, do not force them. Connectors are often keyed and only connect one way. Check for correct orientation.

Computer

The computer contains sensitive components, including a hard drive. Do not handle it roughly. Call your distributor before servicing its internal components. Ask about warranty information as it relates to the PC.

Do not turn the PC power switch on or off. It should remain permanently in the ON position.

Cycle AC power on or off with the cabinet power switch.

A dongle has been inserted into one of the USB ports. This is required for game play.

Do not remove the dongle except for troubleshooting purposes.

Tempered Glass Warning

When handling the LCD display glass cover take special care and set the glass down softly on a flat surface free of debris. The edge of the glass is sensitive to hard impact. Shattered glass from the monitor can travel long distances and cause bodily injury. Use proper procedures when handling broken materials.

Hazard to Epileptics

A small portion of the population has an epileptic condition that may cause seizures. Affected persons experience seizures while watching some television pictures or playing certain video games. People who have not had seizures may still have an undetected epileptic condition. If anyone in your family has experienced epilepsy symptoms (seizures or loss of awareness), consult your physical before using video games. While children play video games, a parent should observe. Be alert to the following symptoms: dizziness, altered vision, eye or muscle twitching, involuntary movements, loss of awareness, disorientation or convulsions. If you or your child experiences these symptoms, discontinue use immediately and consult your physician.

Manual

Keep this manual available and ready for use. Please check our website www.rawthrills.com for the latest information regarding this and other Raw Thrills products. If the game fails to function properly, turn off the machine and unplug the AC line cord. Contact your local distributor. You may not reproduce this document or any of its contents without written authorization from Raw Thrills, Inc. or Play Mechanix™ Inc.

Specifications

For reasons, such as performance, this product's specifications may change without notice. Federal patent, copyright and other intellectual property laws protect the content, devices and design of the game and its equipment.

Product Specifications

Electrical Power

United States, International, and Japan

Operating AC Current: 5/2.5 Amps

Voltage: 115/230 ~ VAC 50/60Hz

Inrush AC Current: 7 Amps

Dimensions

43" Cabinet

Height: 99.75" (2.53 meters)

Width: 46.25" (1.17 meters)

Depth: 33.62" (0.85 meters)

55" Cabinet

Height: 108.87" (2.76 meters)

Width: 56.25" (1.42 meters)

Depth: 34.00" (0.86 meters)

Operating Temperature

50 °F to 104 °F

(10 °C to 40 °C)

Operating Humidity

Must not exceed 95% relative humidity

Fuse Replacement Guide

NOTE: FOR CONTINUED PROTECTION AGAINST
FIRE AND ELECTRICAL DAMAGE, USE ONLY
SPECIFIED FUSE TYPE AND VALUE.

RIO

5VDC = 3A 250V SLO-BLO

12VDC = 5A 250V SLO-BLO

Game Lighting

5A 250V SLO-BLO (x4)

Setup

Unpack Materials

1. Place the shipping crate on a flat, stable surface.
2. Cut the banding straps and remove the cardboard lid.
3. Lift off the large cardboard containers surrounding the cabinet assembly and remove any shipping cleats.
4. Remove the coin door key from the coin return slot.
5. Open the top coin door.
6. Locate the keys for the back doors, the cash box door, and the card dispenser doors.
7. Open the cash box door and remove the cash box.
8. Check for shipping damage to the following:
 - Marquee and monitor
 - Cabinet decals
9. Check the AC line cord for visible signs of damage.
Pay particular attention to the plug and line cord insulation.

43" Cabinet Assembly

Note: 2 people are required, and ladders are recommended. Marquee assembly is heavy!

1. Place cabinet in desired floor location. Setup ladders next to the cabinet for marquee installation.
2. Locate the marquee assembly as well as the following hardware:
 - a. (12) black tamper proof Torx machine screws, $\frac{1}{4}$ - 20 thread, 1-1/2" long
 - b. (12) $\frac{1}{4}$ " black split lock washers
 - c. (12) $\frac{1}{4}$ " black flat washers
3. Using a T-27 bit, securely mount the marquee assembly atop the cabinet as shown in the assembly setup diagram, avoiding any pinching/crushing of the wire harness.

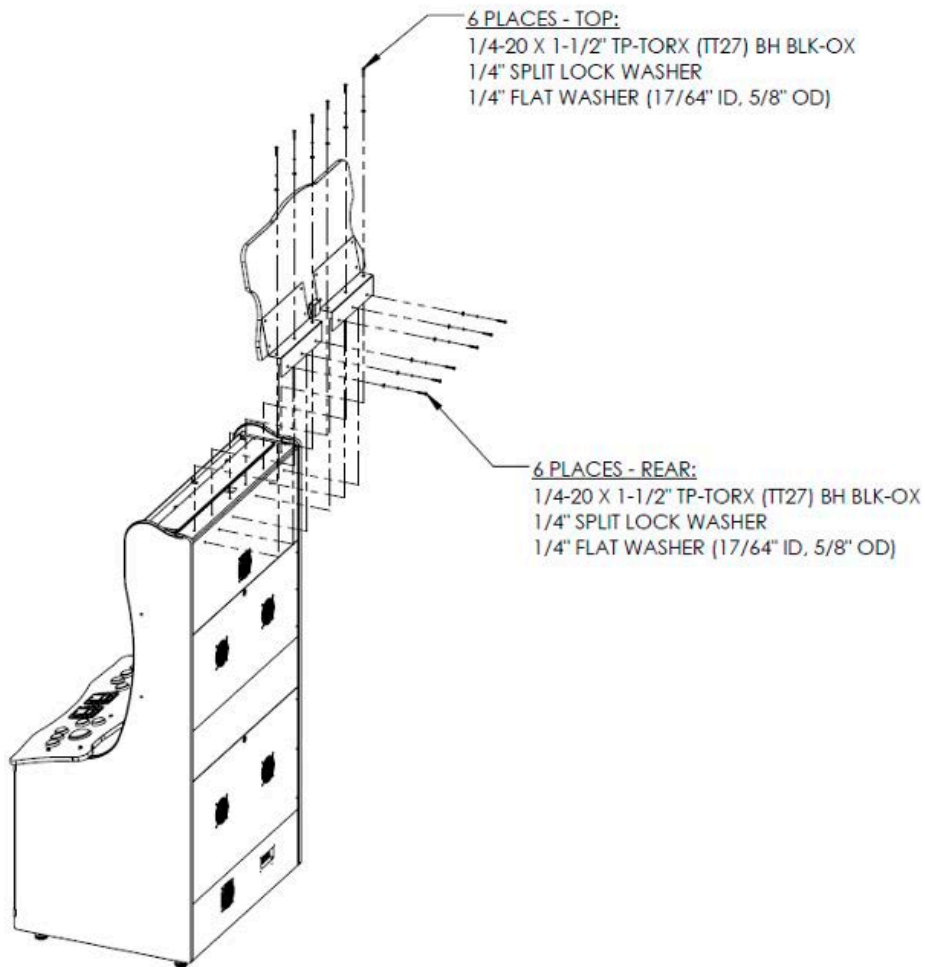

55" Cabinet Assembly

Note: 2 people are required, and ladders are recommended. Marquee assembly is heavy!

4. Place cabinet in desired floor location. Setup ladders next to the cabinet for marquee installation.
5. Locate the marquee assembly as well as the following hardware:
 - a. (12) black tamper proof Torx machine screws, 1/4 - 20 thread, 1-1/2" long
 - b. (12) 1/4" black split lock washers
 - c. (12) 1/4" black flat washers
6. Using a T-27 bit, securely mount the marquee assembly atop the cabinet as shown in the assembly setup diagram, avoiding any pinching/crushing of the wire harness which should pass through the access hole. Connect marquee harness to cabinet harness.

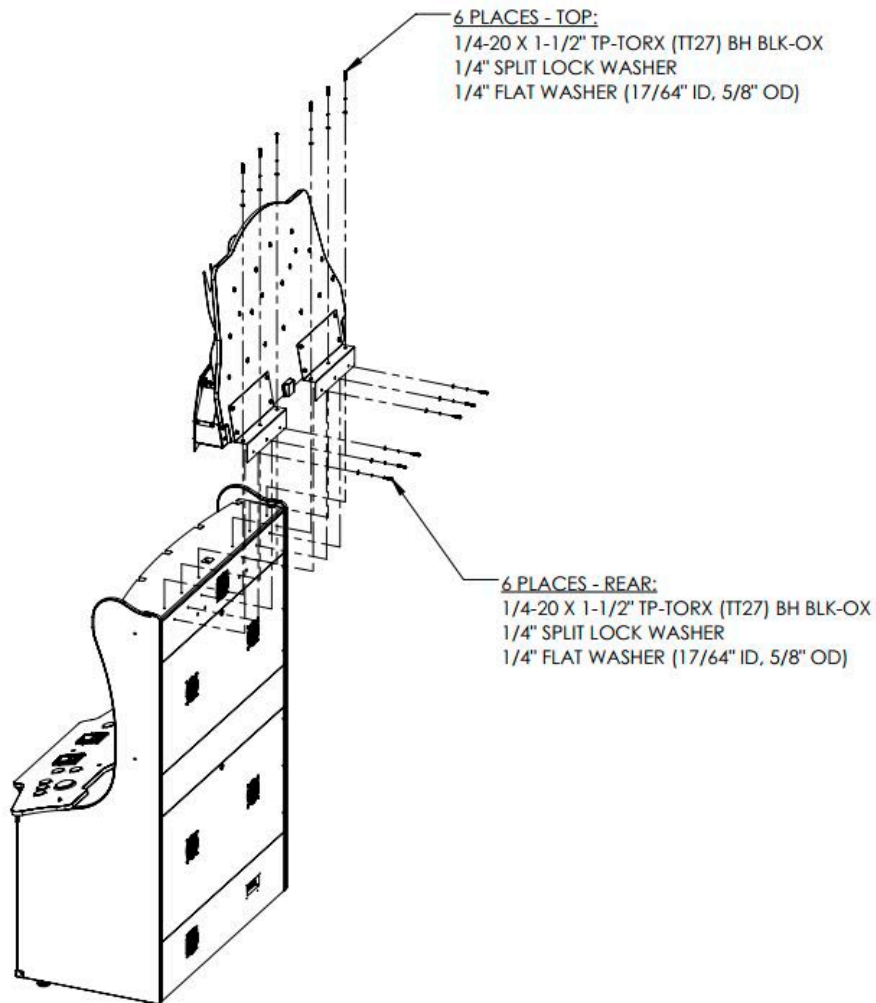

Check Electrical Settings

1. Verify the voltage of the AC outlet you will be plugging the game into.
2. Verify the AC outlet ground connection is present and working.

Startup Game

1. Plug the line cord into an AC outlet.
2. Turn the main cabinet power switch on.
3. Verify the game and all components are operating normally. See *Basic Functional Test on Initial Power Up* in the *Diagnostics and Adjustments* section for the recommended procedure.
4. Authorize a set of cards. See *Authorizing More Cards* under the *Cards and Card Dispensers* section.

Diagnositics and Adjustments

Service Panel

The Service Panel is located behind the coin door and has four buttons that can be used to navigate the Test Menu system. There is also a USB on the Service Panel that can be used for software updates and audit downloads.

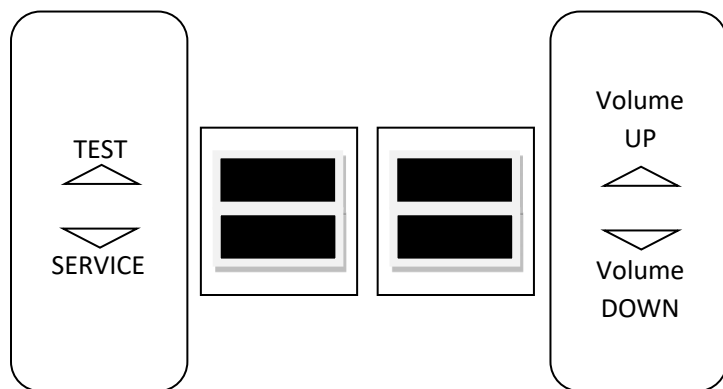

(Service Panel)

Basic Functional Test on Initial Power Up

1. Enter the Input Test and verify all switch inputs are working.
2. Enter the Monitor Test and verify the monitor is working properly.
3. Enter the Sound Test and verify the audio works and is not distorted.
4. Enter the Light Test and verify that all the lights are working properly.
5. Enter the Coin Meter Test and verify the coin meter is working properly.
6. Enter the Scanner Test and verify both Player 1 and Player 2 card scanners are working properly.
7. Enter the Dispenser 1 Test and verify the Player 1 dispenser is working properly.
8. Enter the Dispenser 2 Test and verify the Player 2 dispenser is working properly.
9. Enter the Watchdog Test and verify the game reboots.
10. Upon a successful reboot, you are ready to adjust pricing, volume and other functions.

Test Menu Navigation

In addition to the buttons on the Service Panel, you can also use the Start and Gameplay buttons to navigate through the Test Menus.

Navigating the Test Menu	
Button	Action
TEST/BACK (Not in Test Menu)	Enters Test Menu (Hold for 2+ seconds)
TEST/BACK (In Test Menu)	Selects Highlighted Option
SERVICE (Not on Main Menu)	Cancel Selection
VOLUME UP	Move Up
VOLUME DOWN	Move Down
Start Buttons	Selects Highlighted Option
P1 & P2 Quick Attack	Move Up
P1 & P2 Block	Move Down
P1 & P2 Strong Attack	Selects Highlighted Option

Test Menus

Main Menu

Choose from all available operator settings and menus here.

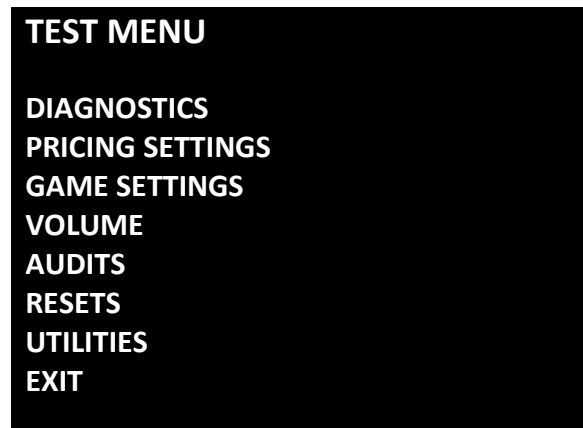

Diagnosics

This menu contains various tests you can run to ensure everything on the cabinet is working properly.

DIAGNOSTICS

INPUT TEST

MONITOR TEST

SOUND TEST

LIGHT TEST

COIN METER TEST

SCANNER TEST

DISPENSER 1 TEST

DISPENSER 2 TEST

SMART CARD TEST

WATCHDOG TEST

EXIT

- **Input Test**: Test all switch inputs on the cabinet
- **Monitor Test**: Tests the cabinet's monitor
- **Sound Test**: Tests cabinet speakers
- **Light Test**: Tests all lighting on the cabinet
- **Coin Meter Test**: Tests functionality of physical coin meter
- **Scanner Test**: Test for both card scanners
- **Dispenser 1 Test**: Tests player 1 card dispenser
- **Dispenser 2 Test**: Tests player 2 card dispenser
- **Smart Card Test**: Tests RFID smart card reader
- **Watchdog Test**: Tests Functionality of watchdog (Game will reboot if working properly)

Pricing Settings

This menu allows for the customization of different pricing related settings.

PRICING SETTINGS

SEPARATE CREDIT POOLS

FREEPLAY

UNIT

UNIT VALUE

UNITS / CREDIT

UNITS / BILL PULSE

CREDITS TO START

CREDITS TO CONTINUE

EXIT

- **Separate Credit Pools**: Separates Player 1 and Player 2 credits and such that each player can only use the credits they have added (This setting is most commonly used for electronic swipe locations).
- **Freeplay**: No coins or swipes needed to play
- **Unit**: Choose between Coins, Card Swipes, or Currency
- **Unit Value**: Currency value per unit
- **Units / Credit**: Cost per game credit
- **Units / Bill Pulse**: Number of Units counted per DBV pulse
- **Credits to Start**: Cost to play from attract mode
- **Credits to Continue**: Cost to play from continue screen

Notes:

- Adjusting the number of units per credit will clear any currently stored partial credits.
- Adjusting Credit Pools will clear all credits.
- Separate Credit Pools feature is not compatible with DBV

Game Settings

This menu allows you to adjust various settings related to game play.

GAME SETTINGS

MATCH TIME

EXIT

- **Match Time**: Adjusts how the maximum amount of time a match can last

Volume

This menu allows you to adjust the volume levels for the game.

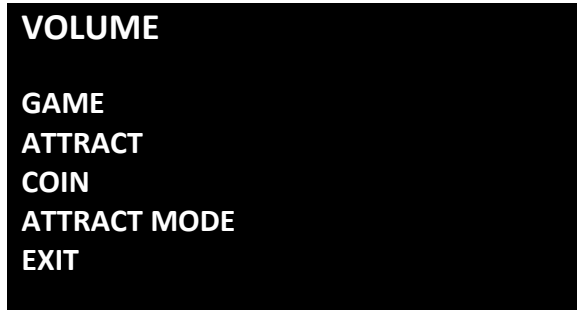

- **Game**: Sets the in-game volume level
- **Attract**: Sets the attract mode volume level
- **Coin**: Sets the volume level of the coin in sound
- **Attract Mode**: Determines the frequency at which sound is played during the attract mode. You can choose from: On, Off, and Sometimes.

Audits

This menu allows you to view a wide variety of statistics and information about the game.

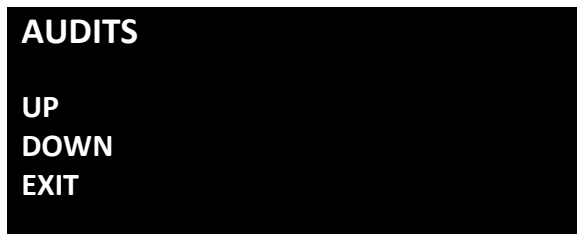

- **Up**: Scrolls up
- **Down**: Scrolls down

Resets

This menu contains all available operator resets for the game.

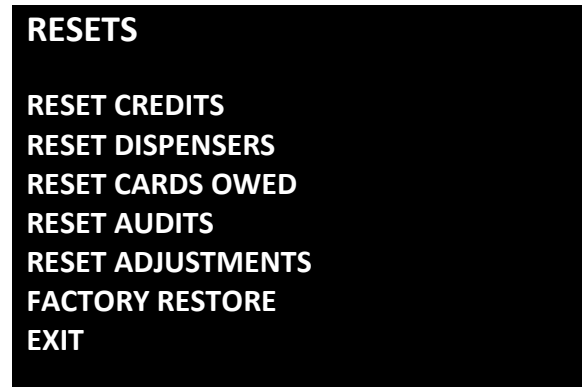

- **Reset Credits**: Clears all currently stored credits
- **Reset Dispensers**: Clears all error codes from dispensers
- **Reset Cards Owed**: Clears cards owed
- **Reset Audits**: Clears audits
- **Reset Adjustments**: Resets all adjustments back to default values
- **Factory Restore**: Completely restores game to the state it came from the factory in

Utilities

This menu has a few miscellaneous operator tools and settings.

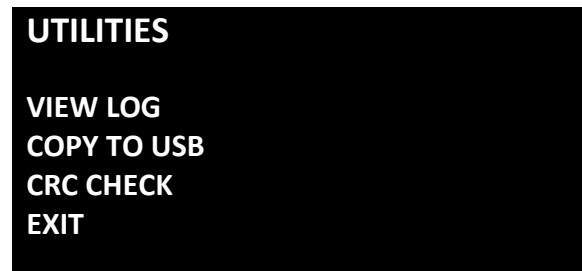

- **View Log**: Allows you to view the game's logs
- **Copy to USB**: Copies the audits and logs to a USB drive
- **CRC Check**: Reruns the crc check on the game's files

Cards and Card Dispensers

Note:

Using damaged (bent, ripped, etc.) cards in the card dispenser(s) can cause damage to the dispenser(s).

Refilling Card Dispensers

Note: Do not eject card hopper when refilling card dispensers, as this may damage the dispenser.



1. Open the card dispenser door.
2. Remove the weight from the card hopper.
3. Add cards to the card hopper, making sure to leave enough room for the weight.
4. Place the weight back into the card hopper.
5. Close the card dispenser door.

Clearing Card Dispenser Jam

1. Open the card dispenser door.
2. Remove the weight from the card hopper.
3. Remove all loose (non-jammed) cards from the card hopper.
4. Carefully remove any jammed cards.
5. Check cards for damage and discard any damaged cards.
6. Put the undamaged cards back into the card hopper.
7. Place the weight back into the card hopper.
8. Close the card dispenser door.

Authorizing More Cards

1. Remove the serialized RFID card included with your new box of cards. (See Image 1 Below)
2. Open the top coin door.
3. Make sure the game is in Attract Mode.
4. Place the RFID card on the Smart Card Reader, which can be found near the Service Panel. (See Image 2 Below)
5. Wait for the authorization process to complete. Once the authorization process is complete, an on-screen message will appear verifying the new cards have been authorized. This process can take up to 30 seconds.
6. Remove the used RFID card.
7. Close the coin door.



Image 1

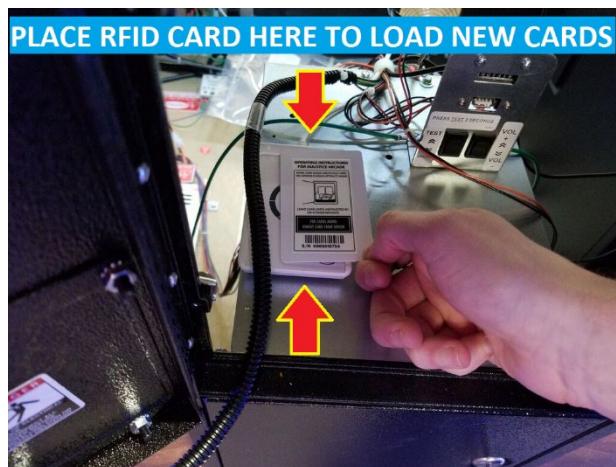

Image 2

PC Hardware

Your Injustice Arcade™ uses a HP Elitedesk 705 G3 MT computer with a GeForce GTX 1050 graphics card. Listed below are the recommended BIOS settings for the computer.

NOTE 1

The computer shipped with the correct BIOS settings. Making changes to the BIOS different from the settings listed below may adversely affect the game's functionality.

NOTE 2

In the event your video card needs to be replaced, any brand of GeForce GTX 1050 will work.



(HP Elitedesk 705 G3 MT)

HP Elitedesk 705 G3 MT BIOS

To Access BIOS Settings:

With the computer powered off, plug a USB keyboard into an open USB slot. Hold the 'F10' key and turn the computer on. Continue holding the F10 key until the BIOS Setup screen appears.

Note: All settings not listed should remain their default values.

Advanced

- + Boot Options
 - After Power Loss..... [POWER ON]
 - UEFI Boot Order:..... [DISABLE]
 - Legacy Boot Order (defaults):
 - USB
 - SATA CD
 - STATO
 - NETWORK BOOT

- + Built-in Device Options
 - Integrated Video:..... [DISABLE]

Note: After exiting BIOS settings screen, power cycle the cabinet by using the cabinet's main power switch.

PC Hard Drive Recovery

Symptoms requiring a PC hard drive recovery include:

- File test reports bad or missing files.
- Game fails to finish loading during setup.
- After resetting the AC power, an error is reported.
- Erratic Game or Attract Mode behavior.

The only way to repair corrupt files is to reinstall the software as described below:

Computer

The computer contains sensitive components. Do not handle roughly. Call your distributor before servicing its internal components. Ask about warranty information as it relates to the PC.

Do **not** use the PC on/off switch. Turn AC power on or off with the cabinet power switch.

Steps to Re-Install the software:

1. Insert installation media into computer. (USB or DVD)
2. Turn cabinet power OFF and wait 30 seconds.
3. Turn cabinet power ON.
4. If using USB installation, select the desired game from the menu.
5. Follow all onscreen instructions.
6. Once installation is complete, remove the installation media and power cycle the game.
7. Your game is now restored and ready to go.

Troubleshooting

Warning: Review the Safety section before making any adjustments to the game.

Problem	Possible Cause	Solution
Game will not power up.	Game not plugged in.	Plug game into AC outlet.
	Game not turned on.	Turn on main power switch.
	Game fuse is blown.	Check and replace fuse. See Specification section for fuse values.
	No power to receptacle.	Test AC outlet and plug game into powered outlet.
	PC BIOS set incorrectly.	See BIOS Settings section.
	Flash Drive Installer is left connected to PC.	Disconnect Flash Drive Installer and power cycle the game.
Buttons do not work.	Faulty micro switch.	Replace the micro switch on the button and re-test. Verify that the wires are connected to the correct spades on the micro switch.
	Faulty wiring.	Disconnect the cabinet from AC power. Verify that all wires are firmly connected to each button and the PCB. Verify that no wires are frayed or improperly shorting to ground. Verify that wires are connected to the correct spades on the micro switches.
	Faulty PCB.	Ensure all connections to PCB are secure. Replace PCB if faulty.

Problem	Possible Cause	Solution
Neither buttons nor audio work.	PCB connected to faulty USB port (boot message may indicate not detected)	To test a USB port, turn off the game, disconnect the device from the port, and then connect the game dongle to the port. Reboot the game. A No Dongle message indicates the port is bad. If the game starts, the port is working. After the test, reconnect all devices to the correct USB ports and reboot.
No sound or bad sound.	Bad connection.	Check connection to speakers.
	Volume set too low.	Use VOL UP button on Test panel to raise volume
	Faulty wiring.	Verify all wires are firmly connected to the speakers, PCB, and green computer audio port. Verify that each wire is connected to the correct port and no wires are frayed or improperly shorting to ground.
	Blown speakers.	Remove the grill and inspect each speaker for visible damage. Run the Sound Test from System Tests in the Operator Menu to verify each speaker is working.
	Reversed wires.	A weak or low muffled sound is a sign of reversed speaker wires. Check for reversed wires on each speaker.
Faulty PCB.	To verify audio is working at the computer, connect stereo headphones to the green computer audio port.	

Problem	Possible Cause	Solution
Constant low audio hum.	Faulty power supply.	Check external DC supply and the PC supply.
	Open ground.	Check all ground wires in cabinet. Ensure AC wall outlet is properly grounded
Game does not load.	PC hard drive failure.	Recover hard drive. See Flash Installer Document or contact your distributor for the latest software revision.
PC Drive test reports “bad” or “missing” files.		
Game fails to finish loading.		
After resetting, game still reports an error.		
Erratic game mode or attract mode.		
WARNING! Data files Corrupted. (Game Operation May Become Unstable.) Use “Test” Switch to Enter Test Mode and Run “File Test.”		
Game Resets	Bad file.	Run Flash Installer.
No Video	PC not turned on.	Turn PC power switch on. Ensure IEC cable tightly plugged in. Trace cable back to source to ensure continuity.
	Video cable not secure.	Check and secure DVI or HDMI connector to Monitor. Check and secure DVI or HDMI connector to PC.
Coin meter does not click during test.	No pulse to meter.	Check wiring from meter to PCB board.
	Faulty meter.	Replace coin meter.
	Blown fuse(s) on PCB	Replace 12vdc 5A fuse(s) on PCB.

Problem	Possible Cause	Solution
Dongle Not Present	Dongle missing or disconnected.	Find dongle cable and reseal in USB port.
	Faulty USB port.	Insert dongle cable in different USB port.
Improper number of credits given when coins or bills are inserted.	Incorrect setting in Pricing Adjustments.	Adjust pricing settings.
	Faulty wiring.	Disconnect cabinet from AC power. Verify wires are firmly connected to coin mech and bill validator and ground wires are properly connected. Verify no wires are frayed or shorting to ground.
	Faulty coin mech.	Verify coin mech is not jammed. Ensure coin mech is properly aligned and latched to coin door.
Exits Test Mode every 3 seconds.	Test button stuck in ON position.	Slide or toggle button off after Test Menu appears
Connect RIO Board or RIO Board Missing.	USB cable disconnected.	Check USB connection from PC to RIO board.
	No Power to RIO board.	Check for proper voltage (+5V, +12V) at RIO P1 connector.
Card Dispenser Not Dispensing (Motor Not Moving)	Card Jammed	See <i>Clearing Card Dispenser Jam</i> in the <i>Cards and Dispensers</i> section.
	Harness Connector Unplugged	Make sure the connector from the wire harness is fully plugged in.
Card Dispenser Not Dispensing (Motor Moving)	Card Jammed	See <i>Clearing Card Dispenser Jam</i> in the <i>Cards and Dispensers</i> section.
	Weight Missing	Ensure weight is in the card hopper on top of the card stack.
	Card Dispenser Too Full	Remove some of the cards from the card hopper.

Problem	Possible Cause	Solution
RFID Card Not Being Recognized	USB Cable Unplugged	Ensure the Smart Card Reader's USB cable is securely plugged in.
	Card Too Far Away	Make sure you're physically touching the RFID card to the Smart Card Reader.
Cards Not Scanning Properly	Card Scanner(s) Unplugged	Ensure the Card Scanner's USB cable is securely plugged in.
	Scanning Window Dirty	Ensure the Scanning Window is clean and that there are no major scratches or marks.
	Scanner LED not Working	Make sure the connector for the LED is fully plugged in.

Technical Support

For an authorized distributor near you, check the Raw Thrills website at www.rawthrills.com

Betson's Raw Thrills Technical Support Hotline

Phone: 1-800-753-2513

FAX: 1-201-438-5019

Email: rtsupport@betson.com



Electrical and Mechanical Illustrations

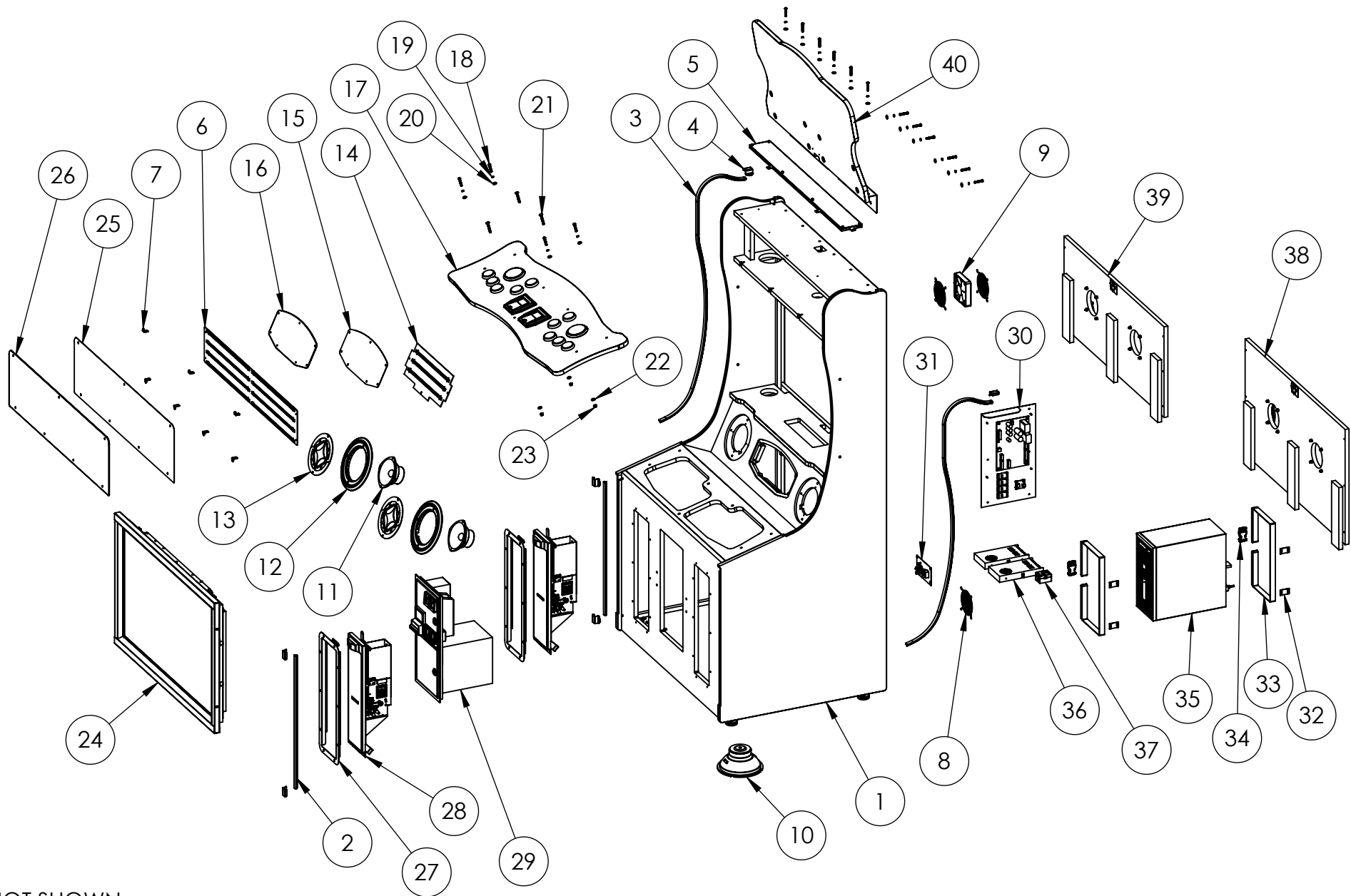

NOT SHOWN:

- > Selective Hardware
- > 380-00005-01 - Smart Card Reader
 - (installed on #29)
- > 500-00131-01 - RGB LED Strip Reel
 - 2X 65CM / 39 LEDs (installed in #2)
 - 2X 145CM / 87 LEDs (installed in #3)

Injustice Arcade - 43" LCD
(BOM on next page)





ITEM NO.	Part Number	Description	QTY.
From BMIGaming.com Global Supplier Of Arcade Games, Sports Games & Amusements - Visit Us At : BMIGaming.com			
1	601-00796-01	Injustice 43" Cabinet	1
2	603-00718-01 (25.625in)	LED T-Molding Extrusion - 25.625"	2
3	603-00718-01 (56.75in)	LED T-Molding Extrusion - 56.75"	2
4	600-01942-01	LED T-Molding Clip	6
5	Injustice_43_Marquee_Light_Panel_Assy	Uplighting Marquee LED Sub-Assembly	1
6	Injustice_43_Marquee_Logo_Backlight_Assy	Logo Marquee LED Sub-Assembly	1
7	600-01434-01	Marquee Top/Bottom Bracket	7
8	800-00001-00	120mm Wire Fan Guard	3
9	820-00001-00	Cooling Fan (standard size): 12VDC, 3W, 80CFM	1
10	2-1-18-00-00-000	Goldwood: 8" Woofer, 4 Ohm, Poly-Mica Cone	1
11	2-1-10-00-00-000	5.25", 8 Ohm Full Range Speaker (Goldwood)	2
12	Injustice_Speaker_Bezel_Assy	Speaker Bezel Sub-Assembly	2
13	600-02070-01	Speaker Grill	2
14	Injustice_43_Mini_Marquee_Backlight_Assy	Mini Marquee LED Sub-Assembly	1
15	606-01365-01	Mini Marquee Translite	1
16	600-02094-01	Mini Marquee Lens PETG	1
17	Injustice_43_CP_Assy	Control Panel Sub-Assembly	1
18	McMaster-Carr - 96075A231	Black-Oxide Alloy Steel Tamper-Resistant Torx Rounded Head Screws, 1/4"-20 Thread Size, 1-1/2" Long	16
19	McMaster-Carr - 93711A500	Black-Oxide 18-8 Stainless Steel Split Lock Washer for 1/4" Socket Head Screws, 0.26" ID, 0.363" OD	16
20	McMaster-Carr - 97416A119	Black-Oxide Steel SAE Flat Washer for 1/4" Screw Size, 0.281" ID, 0.625" OD	16
21	McMaster-Carr - 90185A550	Grade 5 Steel Square-Neck Carriage Bolt, Medium-Strength, 1/4"-20 Thread Size, 2" Long, PAINT BLACK	3
22	McMaster-Carr - 90126A029	Zinc-Plated Steel SAE Washer for 1/4" Screw Size, 0.281" ID, 0.625" OD	3
23	McMaster-Carr - 90675A029	Steel Locknut with External-Tooth Lock Washer, Zinc-Plated, 1/4"-20 Thread Size	3
24	Injustice_43_Monitor_Assy	Monitor Sub-Assembly	1
25	606-01271-01	Marquee Translite	1
26	600-01951-01	Marquee PETG	1
27	600-02060-01	Extended Card Dispenser Door Frame Plate	2
28	Extended_Card_Dispenser_Door_Assy	Card Dispenser Door Sub-Assembly	2
29	800-00005-01	Mid-Width Coin Door Assembly (Suzo-Happ)	1
30	Injustice_RIO_Assy	RIO Assembly w/ Mounting Plate	1
31	AC_Plate_Assy	AC Power Plate Assembly	1
32	600-00891-01	Securing Nylon Strap Plate	4
33	McMaster-Carr - 87425K76	Nylon Fabric Strip, Black, 1" Wide, 0.08" Thick (56" Length)	2
34	McMaster-Carr - 29705T86	Black Plastic Buckle, Squeeze-Release, NO-Sew, for 1" Wide Webbing	2
35	850-00025-01	HP 705 G3 MT w/ GTX 1050 Video Card	1
36	500-00193-01	RSP-320-12: 320W, 12V PFC Dual Voltage Power Supply	2
37	800-00040-01	Magnecraft - Solid State Relay - 6210AXXSZS-DC3 (6210DSX-1)	1
38	Injustice_43_Lower_Back_Door_Assy	Lower Back Door Sub-Assembly	1
39	Injustice_43_Upper_Back_Door_Assy	Upper Back Door Sub-Assembly	1
40	Injustice_43_Marquee_Backboard_Assy	Marquee Backboard Sub-Assembly	1

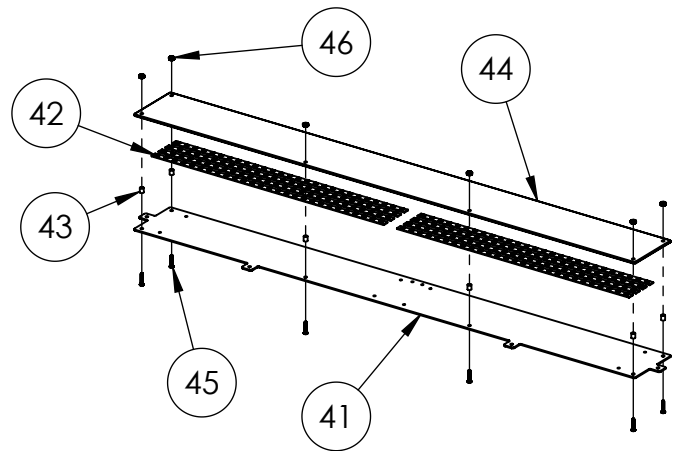

ITEM NO.	PART NUMBER	DESCRIPTION	QTY.
41	600-01947-01	Marquee LED Panel	1
42	500-00162-01 (45 CM)	White Flexible LED Tape, w/ FOAM	8
43	McMaster-Carr - 94639A289	Nylon Unthreaded Spacers, 1/4" OD, 5/16" Length, for Number 8 Screw Size	6
44	600-01948-01	Marquee LED Panel PETG	1
45	McMaster-Carr - 90272A151	Steel Phillips Rounded Head Screws, 6-32 Thread Size, 3/4" Long	6
46	McMaster-Carr - 90675A007	Steel Locknut with External-Tooth Lock Washer, Zinc-Plated, 6-32 Thread Size, 5/16" Wide	6

Injustice Arcade (43") Uplighting Marquee LED Sub-Assembly



ITEM NO.	PART NUMBER	DESCRIPTION	QTY.
47	600-02096-01	Logo LED Panel	1
48	500-00162-01 (45 CM)	White Flexible LED Tape, w/ FOAM	8

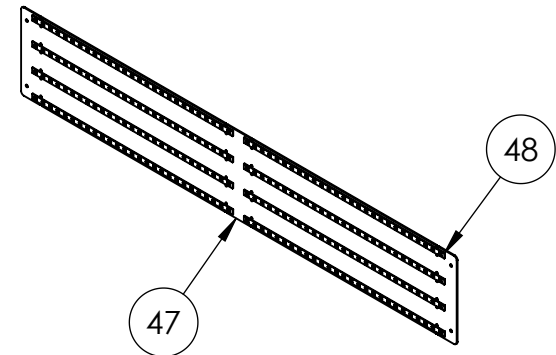

Injustice Arcade (43") Logo Marquee LED Sub-Assembly

ITEM NO.	PART NUMBER	DESCRIPTION	QTY.
49	603-00853-01	Speaker Bezel	1
50	500-00167-01 (45 CM)	Red Flexible LED Tape w/ FOAM	1

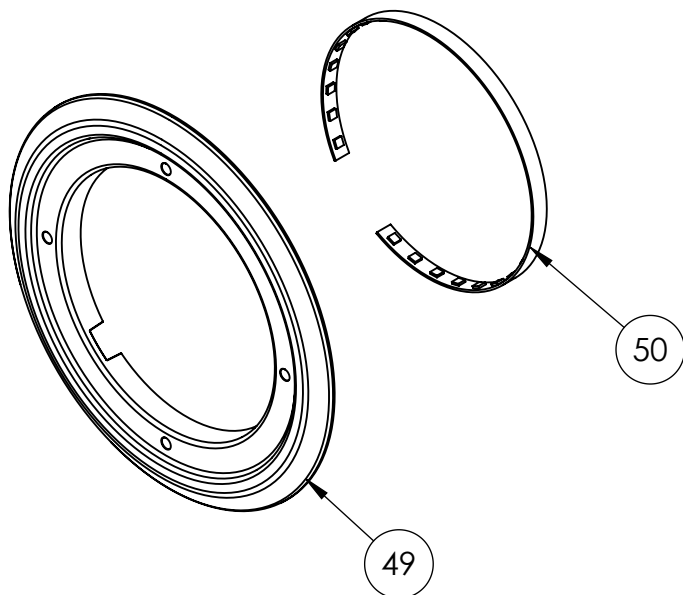

Injustice Arcade (43") Speaker Bezel Sub-Assembly



ITEM NO.	PART NUMBER	DESCRIPTION	QTY.
51	600-02095-01	Mini Marquee LED Panel	1
52	500-00162-01 (35 CM)	White Flexible LED Tape, w/ FOAM	3

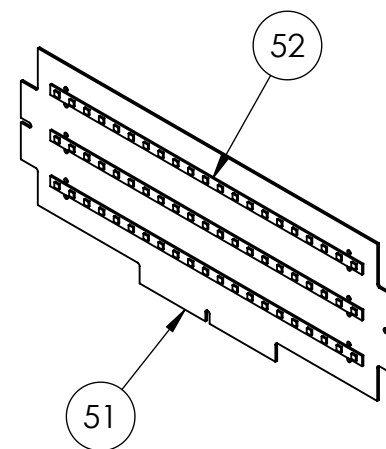

Injustice Arcade (43") Mini Marquee LED Sub-Assembly

ITEM NO.	PART NUMBER	DESCRIPTION	QTY.
53	601-00797-01	Control Panel	1
54	702-00087-01	Large Round RED IPB (.187 Gold MS, 6V White LED) w/ "QUICK" legend	2
55	702-00076-01	Large Round WHITE IPB (.187 Gold MS, 6V White LED) w/ "BLOCK" legend	2
56	702-00088-01	Large Round BLUE IPB (.187 Gold MS, 6V White LED) w/ "STRONG" legend	2
57	702-00085-01	Large Round RED IPB (.187 Gold SW, 6V White LED) w/ "START" legend (P1)	1
58	702-00086-01	Large Round BLUE IPB (.187 Gold SW, 6V White LED) w/ "START" legend (P2)	1
59	702-00084-01	Large Round GREEN IPB (.187 Gold SW, 6V White LED) w/ "BUY CARD ONLY" legend	2
60	702-00077-01	WHITE/CLEAR Jumbo Round With Locking Lampholder (.187 Gold SW, 6V White LED) w/ "SPECIAL ATTACK" legend	2
61	Screw-in Ring Nut	included with IPBs	12
62	Jumbo Mounting Ring	included with Jumbo IPBs	2
63	600-02072-01	Card Reader Glass	2
64	603-00854-01	Card Reader Bezel	2
65	Injustice_Card_Reader_Module_Assy	Card Reader Module Sub-Assembly	2
66	McMaster-Carr - 90316A197	Stainless Steel Flanged Hex Head Screws with Slotted Drive, 8-32 Thread Size, 3/4" Long	4
67	McMaster-Carr - 91102A009	Zinc-Plated Steel Split Lock Washer for Number 8 Screw Size, 0.174" ID, 0.293" OD	12
68	McMaster-Carr - 90126A009	Zinc-Plated Steel SAE Washer for Number 8 Screw Size, 0.188" ID, 0.438" OD	12
69	McMaster-Carr - 91772A211	18-8 Stainless Steel Phillips Rounded Head Screw, 8-32 Thread Size, 1-1/8" Long	8

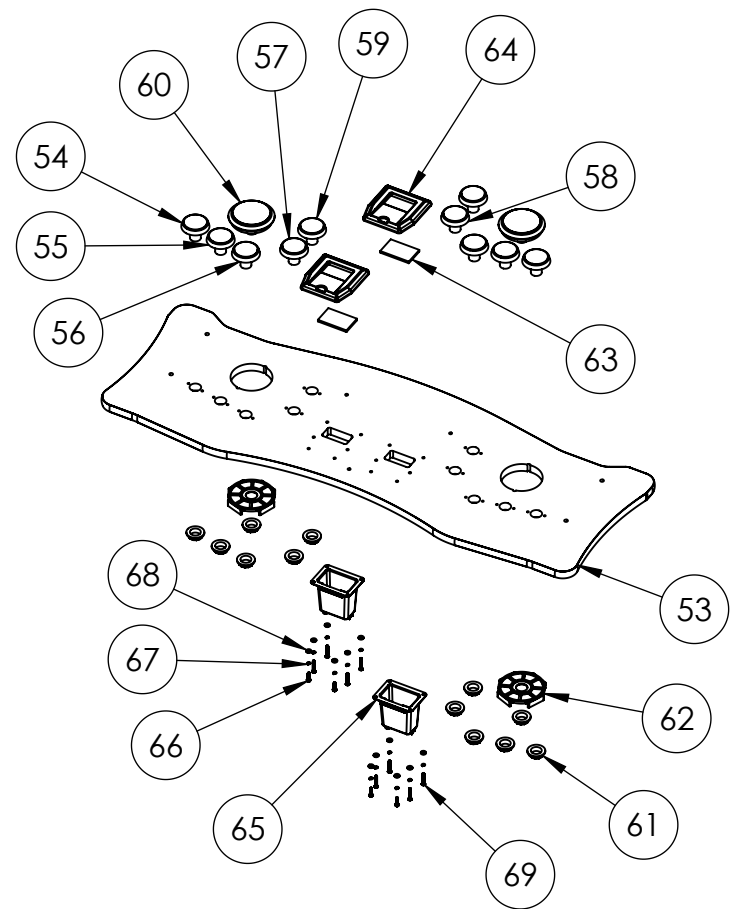

Injustice Arcade (43")
Control Panel Sub-Assembly



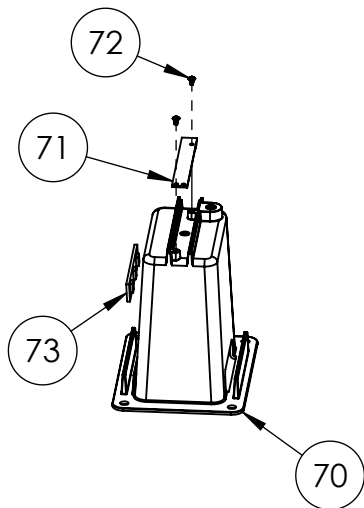

ITEM NO.	PART NUMBER	DESCRIPTION	QTY.
70	603-00855-01	Card Reader Camera Holder	1
71	500-00213-01	CM-020-10CM: Card Reader Webcam	1
72	McMaster-Carr - 99461A605	Phillips Rounded Head Thread-Forming Screws for Plastic, 18-8 Stainless Steel, Number 1 Size, 1/8" Long	2
73	500-00162-01 (5 CM)	White Flexible LED Tape, w/ FOAM	1

Injustice Arcade (43") Card Reader Module Sub-Assembly



ITEM NO.	PART NUMBER	DESCRIPTION	QTY.
74	608-00156-01	Monitor Frame Weldment	1
75	Foam Tape	Black: 1/4"W x 1/8" T x 2"L	2
76	600-00073-01	LCD Display Glass (Tempered)	1
77	809-00004-01	43" HD Monitor	1
78	McMaster-Carr - 90675A011	Steel Locknut with External-Tooth Lock Washer, Zinc-Plated, 10-24 Thread Size	6

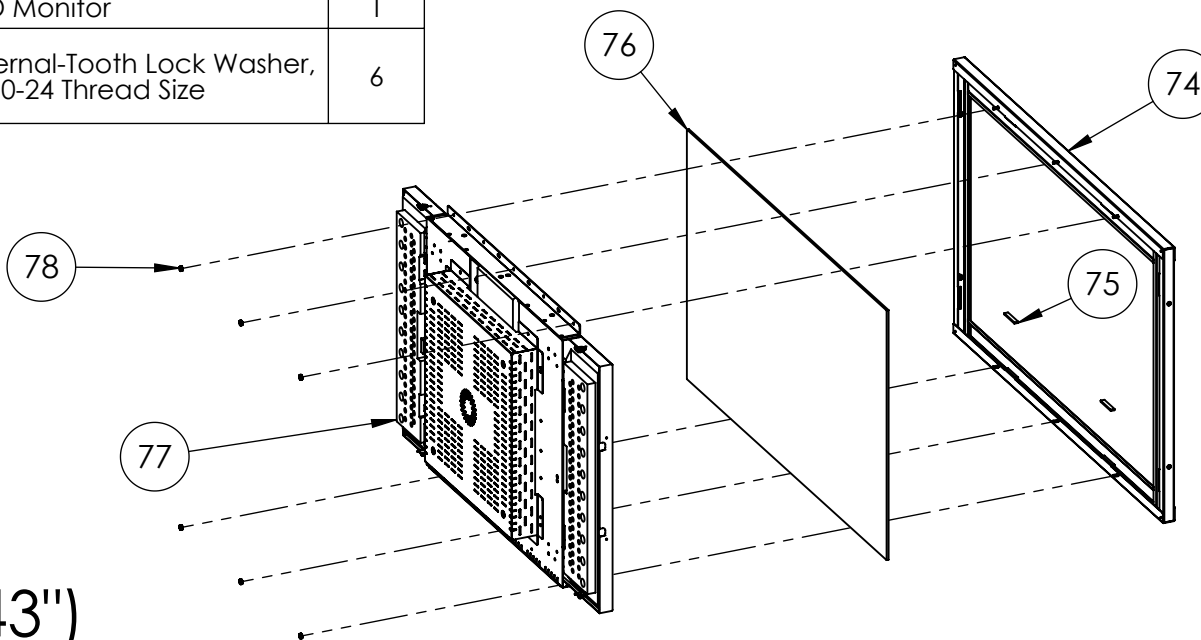

Injustice Arcade (43") Monitor Sub-Assembly

ITEM NO.	PART NUMBER	DESCRIPTION	QTY.
79	608-00229-01	Extended Card Dispenser Door Weldment	1
80	606-01358-01	Card Dispenser Decal	1
81	600-02073-01	Card Dispenser Mounting Plate	1
82	McMaster-Carr - 90640A129	Low-Strength Steel Nylon-Insert Locknut, Zinc-Plated, 1/4"-20 Thread Size	4
83	800-00067-00	CD-1300 Card Dispenser w/ 340 Cassette	1
84	McMaster-Carr - 90317A526	Stainless Steel Rounded Head Screws with External-Tooth Washer, M3 x 0.5 mm Thread, 8 mm Long	4
85	McMaster-Carr - 93825A110	Steel Locknut with External-Tooth Lock Washer, Class 8, Zinc-Plated, M3 x 0.5 mm Thread	4
86	600-02061-01	Card Dispenser Right Stop Bracket	1
87	600-02062-01	Card Dispenser Left Stop Bracket	1
88	McMaster-Carr - 90631A009	Low-Strength Steel Nylon-Insert Locknut, Zinc-Plated, 8-32 Thread Size	4
89	604-00036-01	T-Handle Lock Assy	1
90	McMaster-Carr - 92356A243	18-8 Stainless Steel Square-Neck Carriage Bolt, 10-24 Thread Size, 5/8" Long	2
91	McMaster-Carr - 90631A011	Low-Strength Steel Nylon-Insert Locknut, Zinc-Plated, 10-24 Thread Size	2

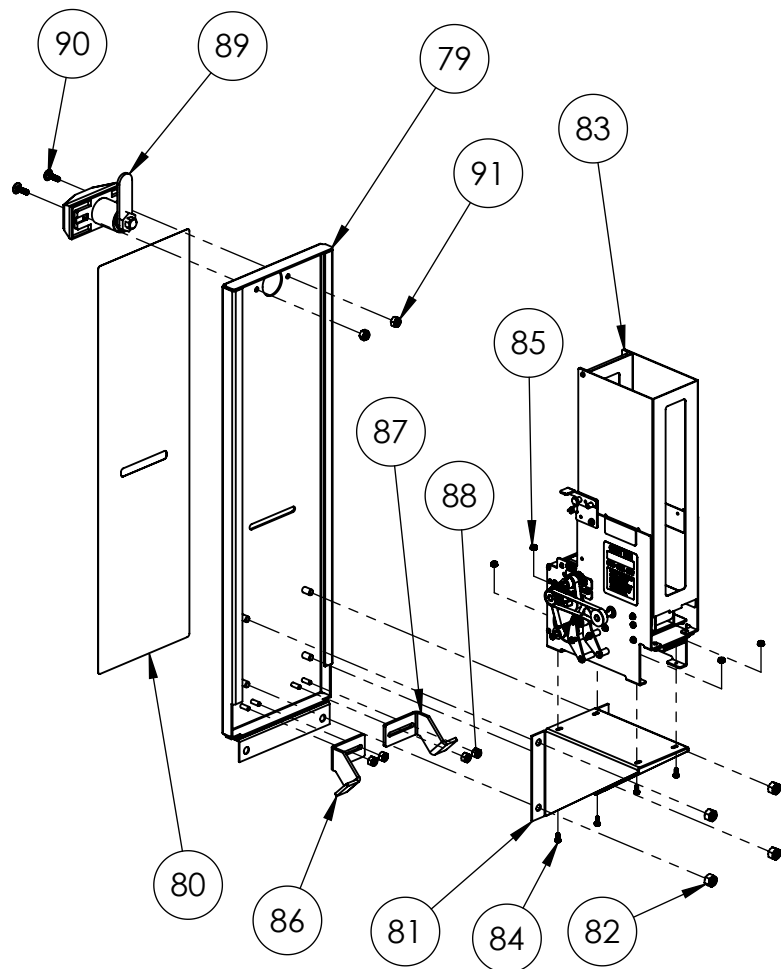

Injustice Arcade (43") Card Dispenser Door Sub-Assembly



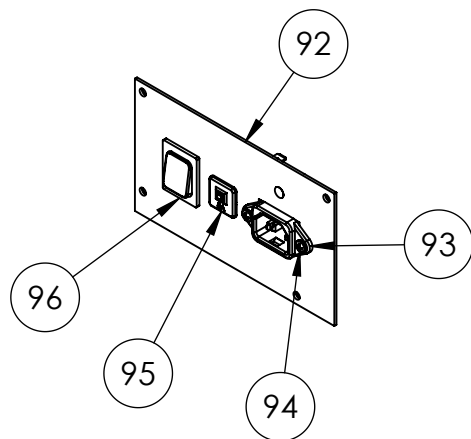

ITEM NO.	PART NUMBER	DESCRIPTION	QTY.
92	600-01681-01	AC Electronics Plate	1
93	703W-00/08	AC Receptacle: 250V, 15A (Qualtek)	1
94	McMaster-Carr - 90272A146	Steel Phillips Rounded Head Screws, 6-32 Thread Size, 3/8" Long	2
95	T9-611P-6	Thermal Circuit Breaker: 240VAC, 6A, Snap-in, Fuseholder, 1-Pole (Schurter)	1
96	1832.3312	Rocker Switch (DPST): 250VAC, 20A (Marquardt)	1

Injustice Arcade (43") AC Power Plate Assembly



ITEM NO.	PART NUMBER	DESCRIPTION	QTY.
97	600-01914-01	RIO Mounting Plate	1
98	500-00040-01	RIO PCB	1
99	McMaster-Carr - 90316A192	Stainless Steel Flanged Hex Head Screws with Slotted Drive, 8-32 Thread Size, 3/8" Long	10
100	500-00194-01	5V, 5A Switching Regulator PCB (12V input)	1
101	520-00024-01	Aliens / Terminator Deluxe Gun Kickboard	4
102	McMaster-Carr - 90272A106	Steel Phillips Rounded Head Screws, 4-40 Thread Size, 1/4" Long	16

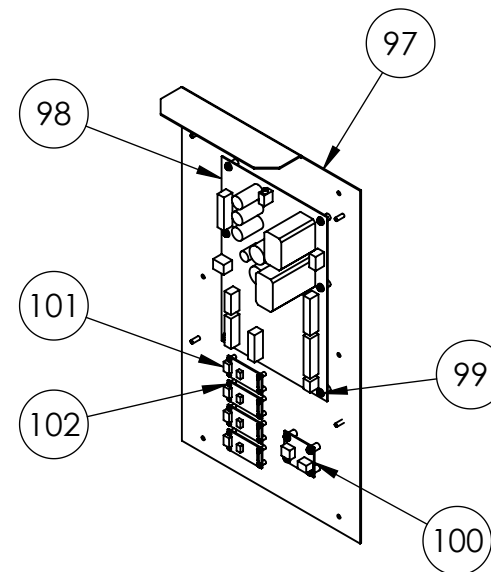

Injustice Arcade (43") RIO Assembly w/ Mounting Plate

ITEM NO.	PART NUMBER	DESCRIPTION	QTY.
103	601-00798-01	Lower Back Door	1
104	800-00001-00	120mm Wire Fan Guard	2
105	McMaster-Carr - 90272A201	Steel Phillips Rounded Head Screws, 8-32 Thread Size, 1-1/4" Long	8
106	McMaster-Carr - 90126A009	Zinc-Plated Steel SAE Washer for Number 8 Screw Size, 0.188" ID, 0.438" OD	8
107	McMaster-Carr - 90631A009	Low-Strength Steel Nylon-Insert Locknut, Zinc-Plated, 8-32 Thread Size	8
108	600-00043-01	Lock Retainer Plate	1
109	McMaster-Carr - 90054A196	Flanged Hex Head Screws for Sheet Metal, Zinc-Plated Steel, Number 8 Size, 5/8" Long	3
110	150-00001-00	Standard Door Lock Assembly (for 3/4" Panels)	1

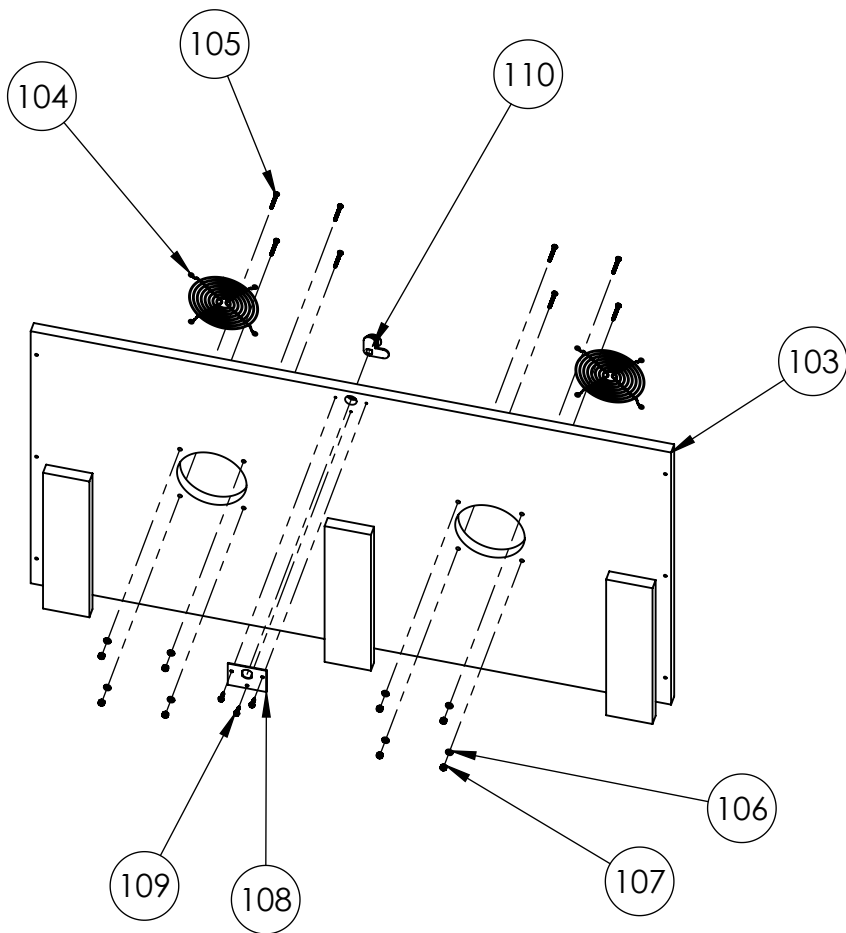

Injustice Arcade (43") Lower Back Door Sub-Assembly



ITEM NO.	PART NUMBER	DESCRIPTION	QTY.
111	601-00799-01	Upper Back Door	1
112	800-00001-00	120mm Wire Fan Guard	2
113	McMaster-Carr - 90272A201	Steel Phillips Rounded Head Screws, 8-32 Thread Size, 1-1/4" Long	8
114	McMaster-Carr - 90126A009	Zinc-Plated Steel SAE Washer for Number 8 Screw Size, 0.188" ID, 0.438" OD	8
115	McMaster-Carr - 90631A009	Low-Strength Steel Nylon-Insert Locknut, Zinc-Plated, 8-32 Thread Size	8
116	600-00043-01	Lock Retainer Plate	1
117	McMaster-Carr - 90054A196	Flanged Hex Head Screws for Sheet Metal, Zinc-Plated Steel, Number 8 Size, 5/8" Long	3
118	150-00001-00	Standard Door Lock Assembly (for 3/4" Panels)	1

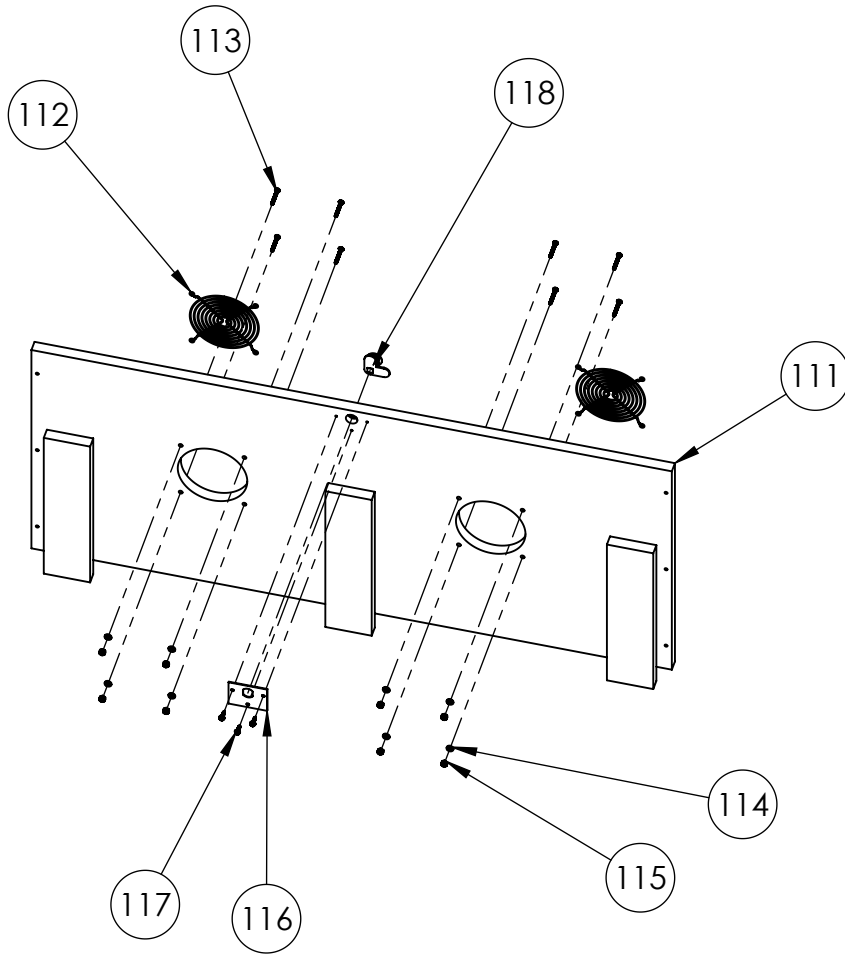

Injustice Arcade (43") Upper Back Door Sub-Assembly



ITEM NO.	PART NUMBER	DESCRIPTION	QTY.
119	601-00813-01	Marquee Panel	1
120	600-02087-01	Marquee Mounting Bracket	2
121	McMaster-Carr - 97416A119	Black-Oxide Steel SAE Flat Washer for 1/4" Screw Size, 0.281" ID, 0.625" OD	8
122	McMaster-Carr - 93711A500	Black-Oxide 18-8 Stainless Steel Split Lock Washer for 1/4" Socket Head Screws, 0.26" ID, 0.363" OD	8
123	McMaster-Carr - 96075A223	Black-Oxide Alloy Steel Tamper-Resistant Torx Rounded Head Screws, 1/4"-20 Thread Size, 1" Long	8
124	600-02089-01	Marquee Harness Plate	1
125	McMaster-Carr - 95638A197	Tamper-Resistant Torx Rounded Head Screws for Sheet Metal, 18-8 Stainless Steel, Number 8 Size, 3/4" Long, PAINT BLACK	2

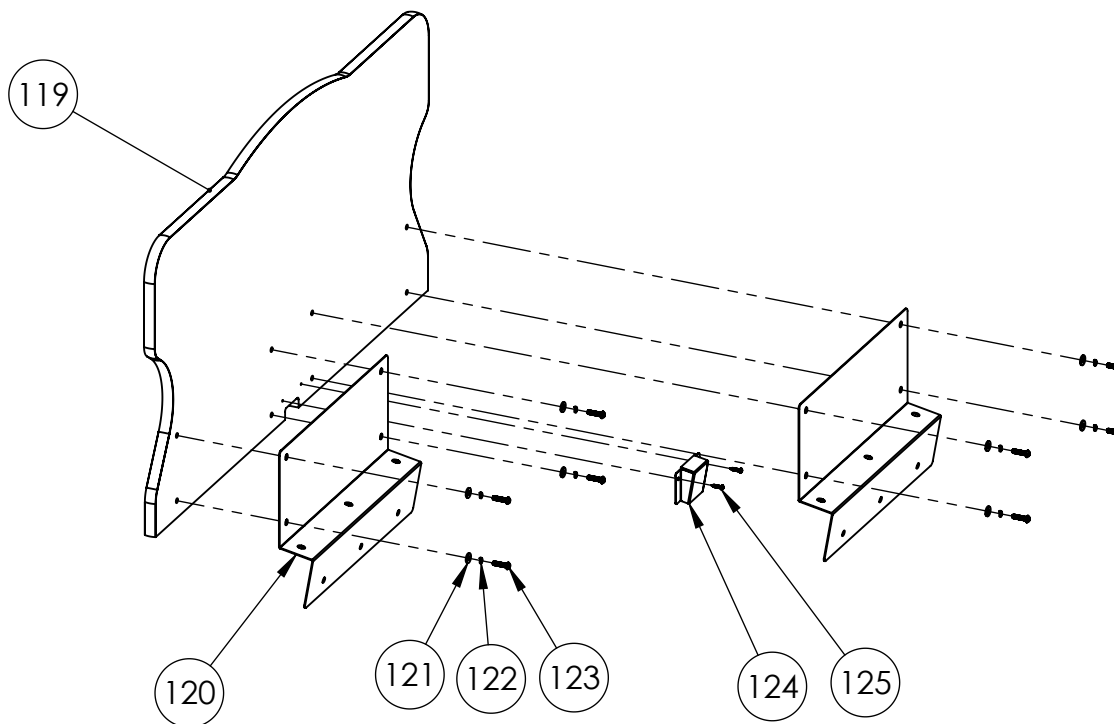

Injustice Arcade (43")
Marquee Backboard Sub-Assembly



ITEM NO.	PART NUMBER	DESCRIPTION	QTY.
126	606-01273-01	Right Side Panel Decal	1
127	606-01274-01	Left Side Panel Decal	1
128	606-01275-01	Front Panel Decal	1
129	606-01279-01	Control Panel Decal	1
130	606-01366-01	Speaker Panel Decal	1
131	606-01276-01	Marquee Background Decal	1

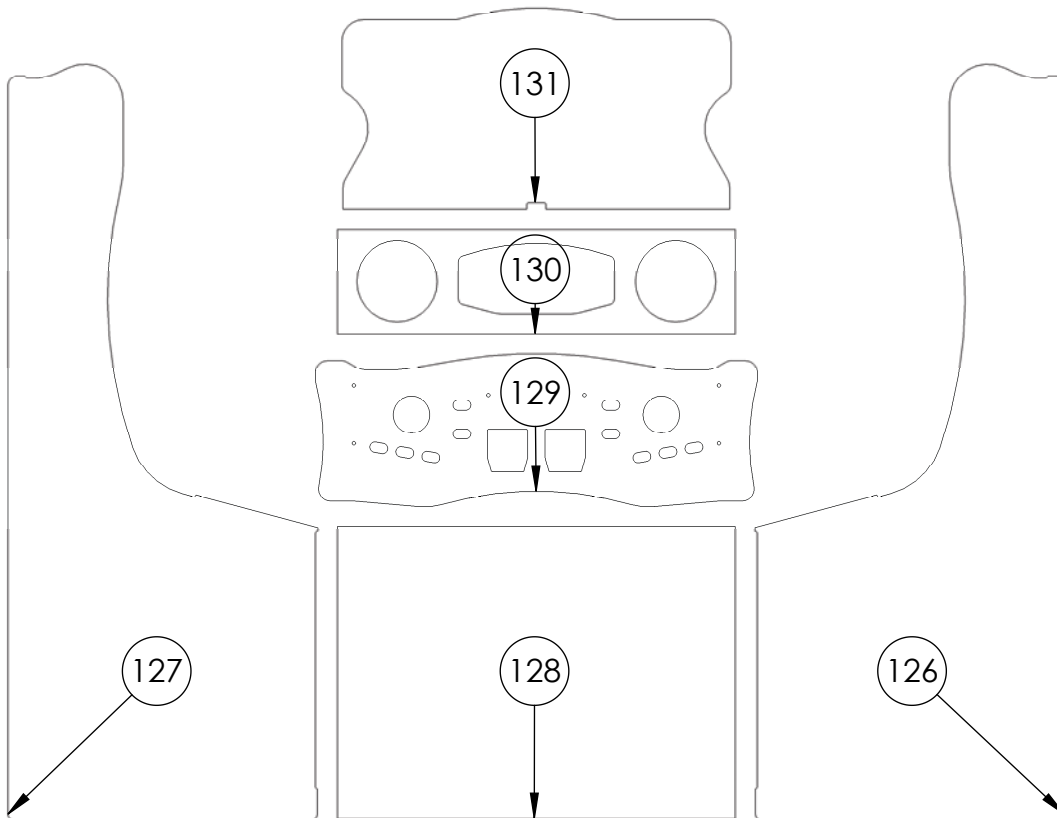

Injustice Arcade (43")
Cabinet Decals



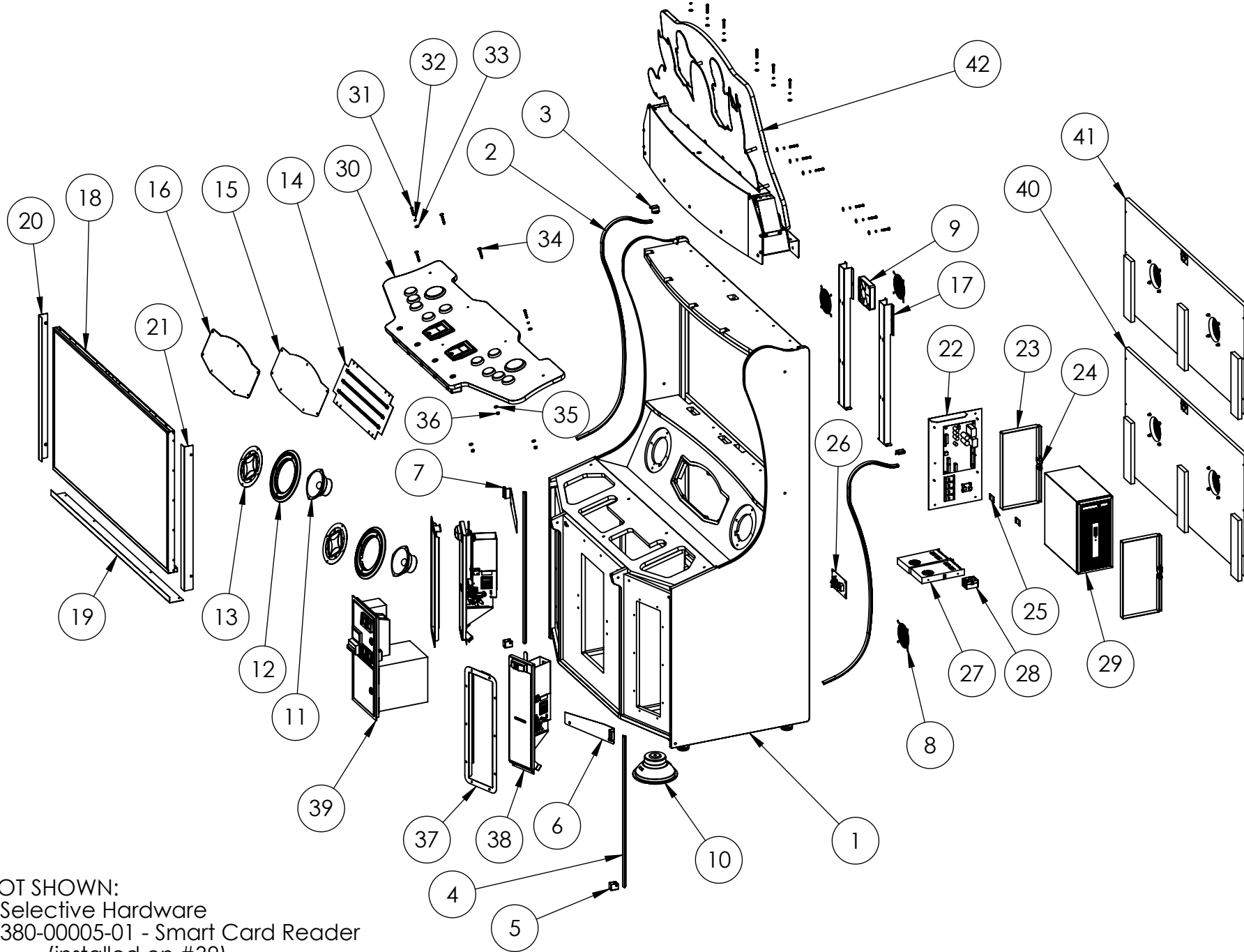

NOT SHOWN:

- > Selective Hardware
- > 380-00005-01 - Smart Card Reader
 - (installed on #39)
- > 500-00131-01 - RGB LED Strip Reel
 - 2X 140CM / 84 LEDs (installed in #2)
 - 2X 75CM / 45 LEDs (installed in #4)

Injustice Arcade - 55" LCD
(BOM on next page)





ITEM NO.	Part Number	Description	QTY.
From BMIGaming.com Global Supplier Of Arcade Games, Sports Games & Amusements - Visit Us At : BMIGaming.com			
1	601-00810-01	Injustice 55" Cabinet	1
2	603-00718-01 (55.625in)	LED T-Molding Extrusion - 55.625"	2
3	600-01942-01	LED T-Molding Clip	2
4	603-00718-01 (29.75in)	LED T-Molding Extrusion - 29.75"	2
5	600-02039-01	LED T-Molding Corner Clip	2
6	600-02037-01	LED T-Molding Angled Plate Right	1
7	600-02038-01	LED T-Molding Angled Plate Left	1
8	800-00001-00	120mm Wire Fan Guard	3
9	820-00001-00	Cooling Fan (standard size): 12VDC, 3W, 80CFM	1
10	2-1-18-00-00-000	Goldwood: 8" Woofer, 4 Ohm, Poly-Mica Cone	1
11	2-1-10-00-00-000	5.25", 8 Ohm Full Range Speaker (Goldwood)	2
12	Injustice_Speaker_Bezel_Assy	Speaker Bezel Sub-Assembly	2
13	600-02070-01	Speaker Grill	2
14	Injustice_55_Mini_Marquee_Backlight_Assy	Mini Marquee LED Sub-Assembly	1
15	606-01349-01	Mini Marquee Translite	1
16	600-02071-01	Mini Marquee Lens PETG	1
17	600-01482-01	LCD Mounting Strut	2
18	809-00012-01	55" Open Frame LCD (with glass)	1
19	600-02091-01	Bottom Monitor Bracket	1
20	600-02092-01	Left Monitor Frame Bracket	1
21	600-02093-01	Right Monitor Frame Bracket	1
22	Injustice_RIO_Assy	RIO Assembly w/ Mounting Plate	1
23	McMaster-Carr - 87425K76	Nylon Fabric Strip, Black, 1" Wide, 0.08" Thick (56" Length)	2
24	McMaster-Carr - 29705T86	Black Plastic Buckle, Squeeze-Release, NO-Sew, for 1" Wide Webbing	2
25	600-00891-01	Securing Nylon Strap Plate	2
26	AC_Plate_Assy	AC Power Plate Assembly	1
27	500-00193-01	RSP-320-12: 320W, 12V PFC Dual Voltage Power Supply	2
28	800-00040-01	Magnecraft - Solid State Relay - 6210AXXSZS-DC3 (6210DSX-1)	1
29	850-00025-01	HP 705 G3 MT w/ GTX 1050 Video Card	1
30	Injustice_55_CP_Assy	Control Panel Sub-Assembly	1
31	McMaster-Carr - 96075A231	Black-Oxide Alloy Steel Tamper-Resistant Torx Rounded Head Screws, 1/4"-20 Thread Size, 1-1/2" Long	14
32	McMaster-Carr - 93711A500	Black-Oxide 18-8 Stainless Steel Split Lock Washer for 1/4" Socket Head Screws, 0.26" ID, 0.363" OD	14
33	McMaster-Carr - 97416A119	Black-Oxide Steel SAE Flat Washer for 1/4" Screw Size, 0.281" ID, 0.625" OD	14
34	McMaster-Carr - 90185A550	Grade 5 Steel Square-Neck Carriage Bolt, Medium-Strength, 1/4"-20 Thread Size, 2" Long, PAINT BLACK	3
35	McMaster-Carr - 90126A029	Zinc-Plated Steel SAE Washer for 1/4" Screw Size, 0.281" ID, 0.625" OD	3
36	McMaster-Carr - 90675A029	Steel Locknut with External-Tooth Lock Washer, Zinc-Plated, 1/4"-20 Thread Size	3
37	600-02060-01	Extended Card Dispenser Door Frame Plate	2
38	Extended_Card_Dispenser_Door_Assy	Card Dispenser Door Sub-Assembly	2
39	800-00005-01	Mid-Width Coin Door Assembly (Suzo-Happ)	1
40	Injustice_55_Lower_Back_Door_Assy	Lower Back Door Sub-Assembly	1
41	Injustice_55_Upper_Back_Door_Assy	Upper Back Door Sub-Assembly	1
42	Injustice_55_Marquee_Assy	Marquee Sub-Assembly	1

ITEM NO.	PART NUMBER	DESCRIPTION	QTY.
43	603-00853-01	Speaker Bezel	1
44	500-00167-01 (45 CM)	Red Flexible LED Tape w/ FOAM	1

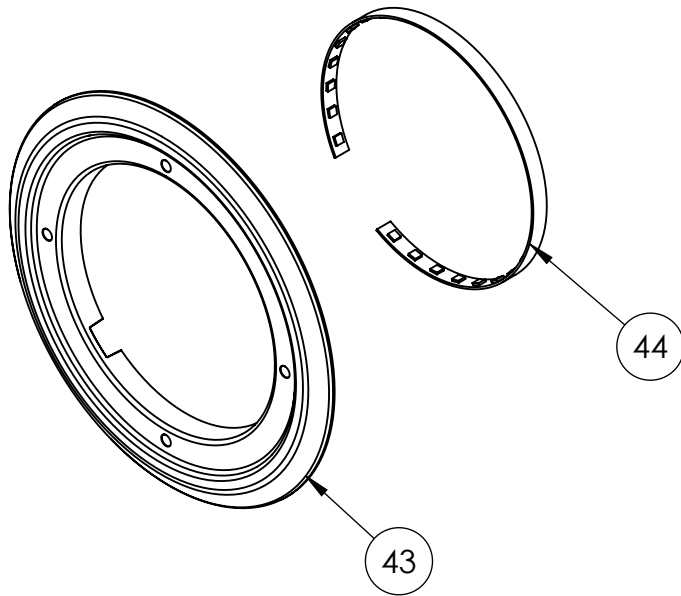

Injustice Arcade (55") Speaker Bezel Sub-Assembly



ITEM NO.	PART NUMBER	DESCRIPTION	QTY.
45	600-02042-01	Mini Marquee LED Panel	1
46	500-00162-01 (45 CM)	White Flexible LED Tape, w/ FOAM	3

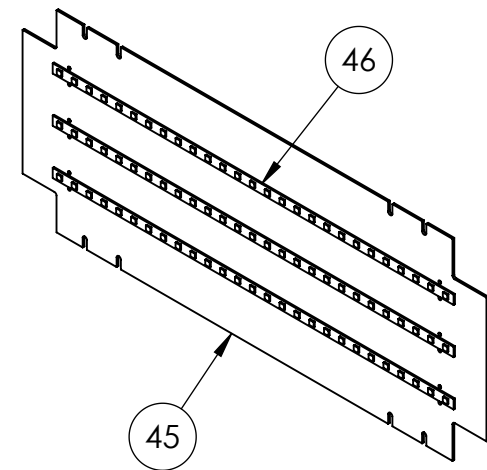

Injustice Arcade (55") Mini Marquee LED Sub-Assembly

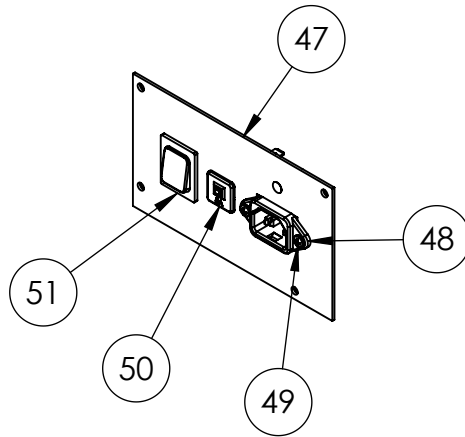

ITEM NO.	PART NUMBER	DESCRIPTION	QTY.
47	600-01681-01	AC Electronics Plate	1
48	703W-00/08	AC Receptacle: 250V, 15A (Qualtek)	1
49	McMaster-Carr - 90272A146	Steel Phillips Rounded Head Screws, 6-32 Thread Size, 3/8" Long	2
50	T9-611P-6	Thermal Circuit Breaker: 240VAC, 6A, Snap-in, Fuseholder, 1-Pole (Schurter)	1
51	1832.3312	Rocker Switch (DPST): 250VAC, 20A (Marquardt)	1

Injustice Arcade (55") AC Power Plate Assembly



ITEM NO.	PART NUMBER	DESCRIPTION	QTY.
52	600-01914-01	RIO Mounting Plate	1
53	500-00040-01	RIO PCB	1
54	McMaster-Carr - 90316A192	Stainless Steel Flanged Hex Head Screws with Slotted Drive, 8-32 Thread Size, 3/8" Long	10
55	500-00194-01	5V, 5A Switching Regulator PCB (12V input)	1
56	520-00024-01	Aliens / Terminator Deluxe Gun Kickboard	4
57	McMaster-Carr - 90272A106	Steel Phillips Rounded Head Screws, 4-40 Thread Size, 1/4" Long	16

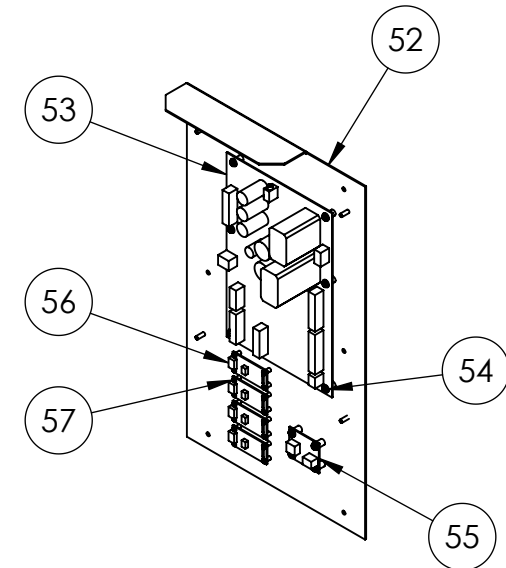

Injustice Arcade (55") RIO Assembly w/ Mounting Plate

ITEM NO.	PART NUMBER	DESCRIPTION	QTY.
58	601-00811-01	Injustice 55" Control Panel	1
59	702-00087-01	Large Round RED IPB (.187 Gold MS, 6V White LED) w/ "QUICK" legend	2
60	702-00076-01	Large Round WHITE IPB (.187 Gold MS, 6V White LED) w/ "BLOCK" legend	2
61	702-00088-01	Large Round BLUE IPB (.187 Gold MS, 6V White LED) w/ "STRONG" legend	2
62	702-00085-01	Large Round RED IPB (.187 Gold SW, 6V White LED) w/ "START" legend (P1)	1
63	702-00086-01	Large Round BLUE IPB (.187 Gold SW, 6V White LED) w/ "START" legend (P2)	1
64	702-00084-01	Large Round GREEN IPB (.187 Gold SW, 6V White LED) w/ "BUY CARD ONLY" legend	2
65	702-00077-01	WHITE/CLEAR Jumbo Round With Locking Lampholder (.187 Gold SW, 6V White LED) w/ "SPECIAL ATTACK" legend	2
66	Screw-in Ring Nut	included with IPBs	12
67	Jumbo Mounting Ring	included with Jumbo IPBs	2
68	600-02072-01	Card Reader Glass	2
69	603-00854-01	Card Reader Bezel	2
70	McMaster-Carr - 90126A009	Zinc-Plated Steel SAE Washer for Number 8 Screw Size, 0.188" ID, 0.438" OD	12
71	McMaster-Carr - 90316A197	Stainless Steel Flanged Hex Head Screws with Slotted Drive, 8-32 Thread Size, 3/4" Long	4
72	Injustice_Card_Reader_Module_Assy	Card Reader Module Sub-Assembly	2
73	McMaster-Carr - 91102A009	Zinc-Plated Steel Split Lock Washer for Number 8 Screw Size, 0.174" ID, 0.293" OD	8
74	McMaster-Carr - 91772A211	18-8 Stainless Steel Phillips Rounded Head Screw, 8-32 Thread Size, 1-1/8" Long	8
75	Injustice_55_CP_Light_Assy	Control Panel Light Sub-Assembly	1
76	McMaster-Carr - 91102A029	Zinc-Plated Steel Split Lock Washer for 1/4" Screw Size, 0.26" ID, 0.487" OD	4
77	McMaster-Carr - 92865A540	Medium-Strength Grade 5 Steel Hex Head Screw, Zinc-Plated, 1/4"-20 Thread Size, 3/4" Long	4

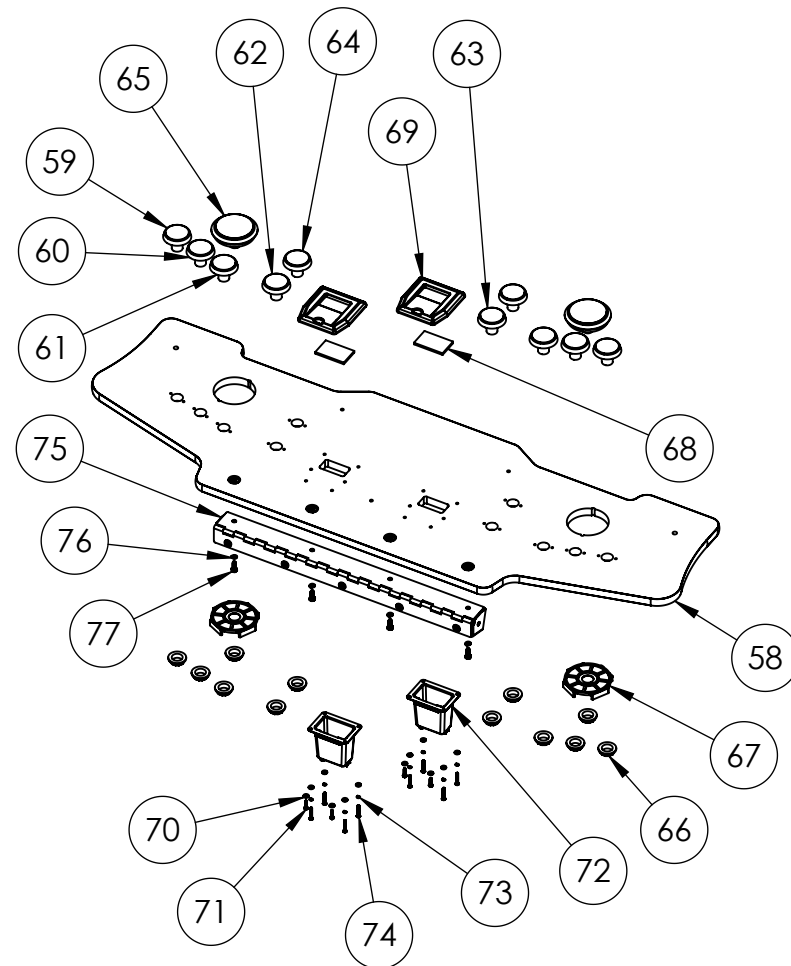

Injustice Arcade (55")
Control Panel Sub-Assembly



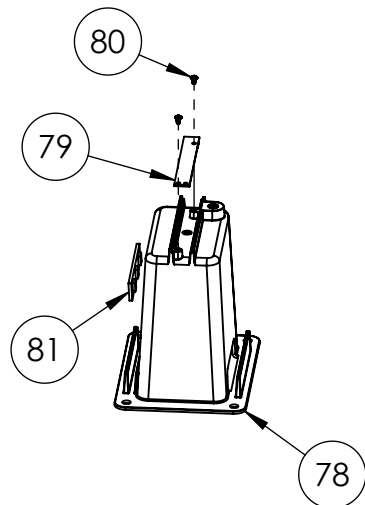

ITEM NO.	PART NUMBER	DESCRIPTION	QTY.
78	603-00855-01	Card Reader Camera Holder	1
79	500-00213-01	CM-020-10CM: Card Reader Webcam	1
80	McMaster-Carr - 99461A605	Phillips Rounded Head Thread-Forming Screws for Plastic, 18-8 Stainless Steel, Number 1 Size, 1/8" Long	2
81	500-00162-01 (5 CM)	White Flexible LED Tape, w/ FOAM	1

Injustice Arcade (55") Card Reader Module Sub-Assembly



ITEM NO.	PART NUMBER	DESCRIPTION	QTY.
82	600-02044-01	Control Panel Light Bracket	1
83	600-02048-01	Control Panel Hinge	1
84	McMaster-Carr - 96075A219	Black-Oxide Alloy Steel Tamper-Resistant Torx Rounded Head Screws, 1/4"-20 Thread Size, 3/4" Long	5
85	McMaster-Carr - 97416A119	Black-Oxide Steel SAE Flat Washer for 1/4" Screw Size, 0.281" ID, 0.625" OD	10
86	McMaster-Carr - 95615A120	Medium-Strength Steel Nylon-Insert Locknut, Grade 5, Zinc-Plated, 1/4"-20 Thread Size	5
87	600-02045-01	Control Panel Light Lens PETG	1
88	McMaster-Carr - 90675A007	Steel Locknut with External-Tooth Lock Washer, Zinc-Plated, 6-32 Thread Size, 5/16" Wide	5
89	McMaster-Carr - 94639A289	Nylon Unthreaded Spacers, 1/4" OD, 5/16" Length, for Number 8 Screw Size	2
90	500-00167-01 (55CM)	Red Flexible LED Tape w/ FOAM	1
91	600-02046-01	Control Panel Light Panel	1

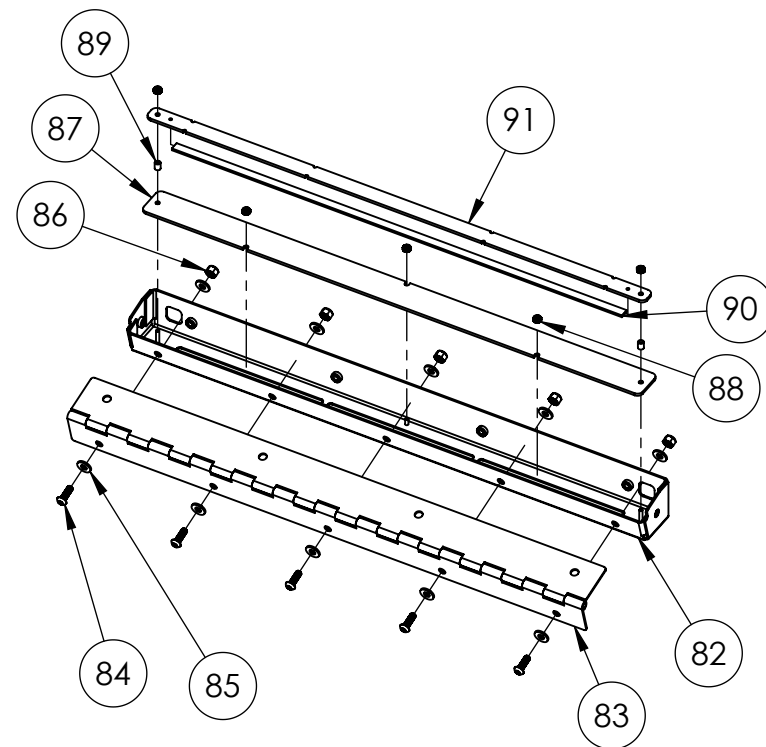

Injustice Arcade (55") Control Panel Light Sub-Assembly

ITEM NO.	PART NUMBER	DESCRIPTION	QTY.
92	608-00229-01	Extended Card Dispenser Door Weldment	1
93	606-01358-01	Card Dispenser Decal	1
94	600-02073-01	Card Dispenser Mounting Plate	1
95	McMaster-Carr - 90640A129	Low-Strength Steel Nylon-Insert Locknut, Zinc-Plated, 1/4"-20 Thread Size	4
96	800-00067-00	CD-1300 Card Dispenser w/ 340 Cassette	1
97	McMaster-Carr - 90317A526	Stainless Steel Rounded Head Screws with External-Tooth Washer, M3 x 0.5 mm Thread, 8 mm Long	4
98	McMaster-Carr - 93825A110	Steel Locknut with External-Tooth Lock Washer, Class 8, Zinc-Plated, M3 x 0.5 mm Thread	4
99	600-02061-01	Card Dispenser Right Stop Bracket	1
100	600-02062-01	Card Dispenser Left Stop Bracket	1
101	McMaster-Carr - 90631A009	Low-Strength Steel Nylon-Insert Locknut, Zinc-Plated, 8-32 Thread Size	4
102	604-00036-01	T-Handle Lock Assy	1
103	McMaster-Carr - 92356A243	18-8 Stainless Steel Square-Neck Carriage Bolt, 10-24 Thread Size, 5/8" Long	2
104	McMaster-Carr - 90631A011	Low-Strength Steel Nylon-Insert Locknut, Zinc-Plated, 10-24 Thread Size	2

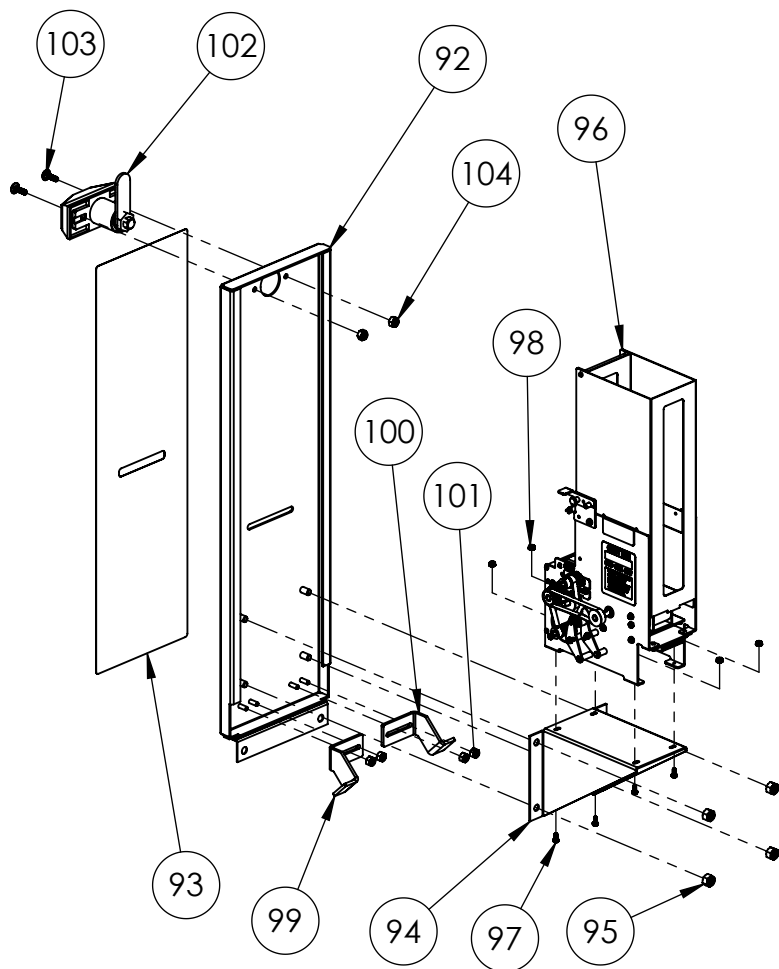

Injustice Arcade (55") Card Dispenser Door Sub-Assembly



ITEM NO.	PART NUMBER	DESCRIPTION	QTY.
105	601-00808-01	Lower Back Door	1
106	800-00001-00	120mm Wire Fan Guard	2
107	McMaster-Carr - 90272A201	Steel Phillips Rounded Head Screws, 8-32 Thread Size, 1-1/4" Long	8
108	McMaster-Carr - 90126A009	Zinc-Plated Steel SAE Washer for Number 8 Screw Size, 0.188" ID, 0.438" OD	8
109	McMaster-Carr - 90631A009	Low-Strength Steel Nylon-Insert Locknut, Zinc-Plated, 8-32 Thread Size	8
110	600-00043-01	Lock Retainer Plate	1
111	McMaster-Carr - 90054A196	Flanged Hex Head Screws for Sheet Metal, Zinc-Plated Steel, Number 8 Size, 5/8" Long	3
112	150-00001-00	Standard Door Lock Assembly (for 3/4" Panels)	1

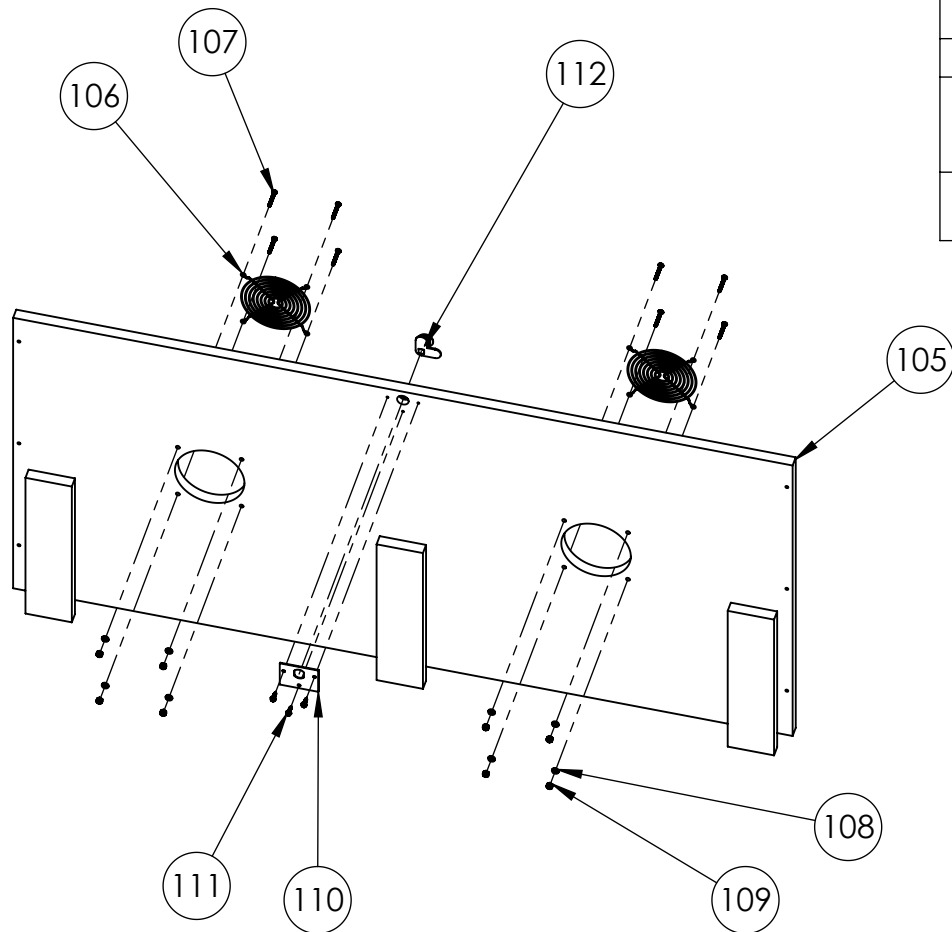

Injustice Arcade (55") Lower Back Door Sub-Assembly



ITEM NO.	PART NUMBER	DESCRIPTION	QTY.
113	601-00809-01	Upper Back Door	1
114	800-00001-00	120mm Wire Fan Guard	2
115	McMaster-Carr - 90272A201	Steel Phillips Rounded Head Screws, 8-32 Thread Size, 1-1/4" Long	8
116	McMaster-Carr - 90126A009	Zinc-Plated Steel SAE Washer for Number 8 Screw Size, 0.188" ID, 0.438" OD	8
117	McMaster-Carr - 90631A009	Low-Strength Steel Nylon-Insert Locknut, Zinc-Plated, 8-32 Thread Size	8
118	600-00043-01	Lock Retainer Plate	1
119	McMaster-Carr - 90054A196	Flanged Hex Head Screws for Sheet Metal, Zinc-Plated Steel, Number 8 Size, 5/8" Long	3
120	150-00001-00	Standard Door Lock Assembly (for 3/4" Panels)	1

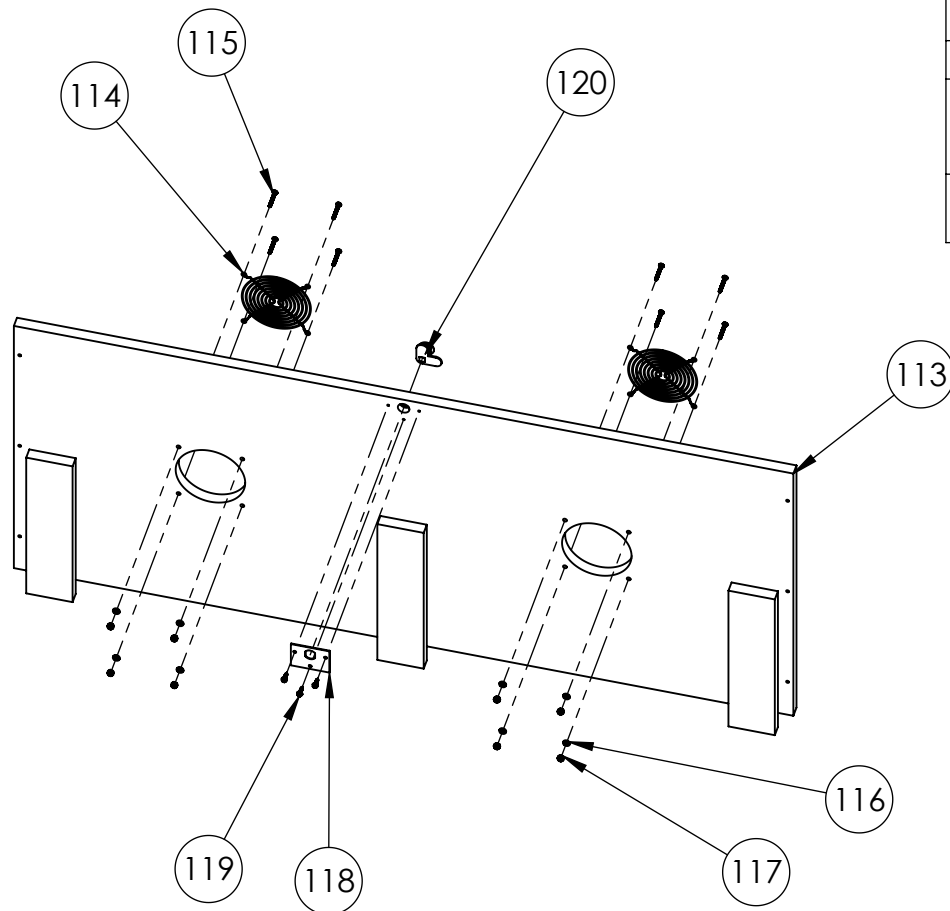

Injustice Arcade (55") Upper Back Door Sub-Assembly



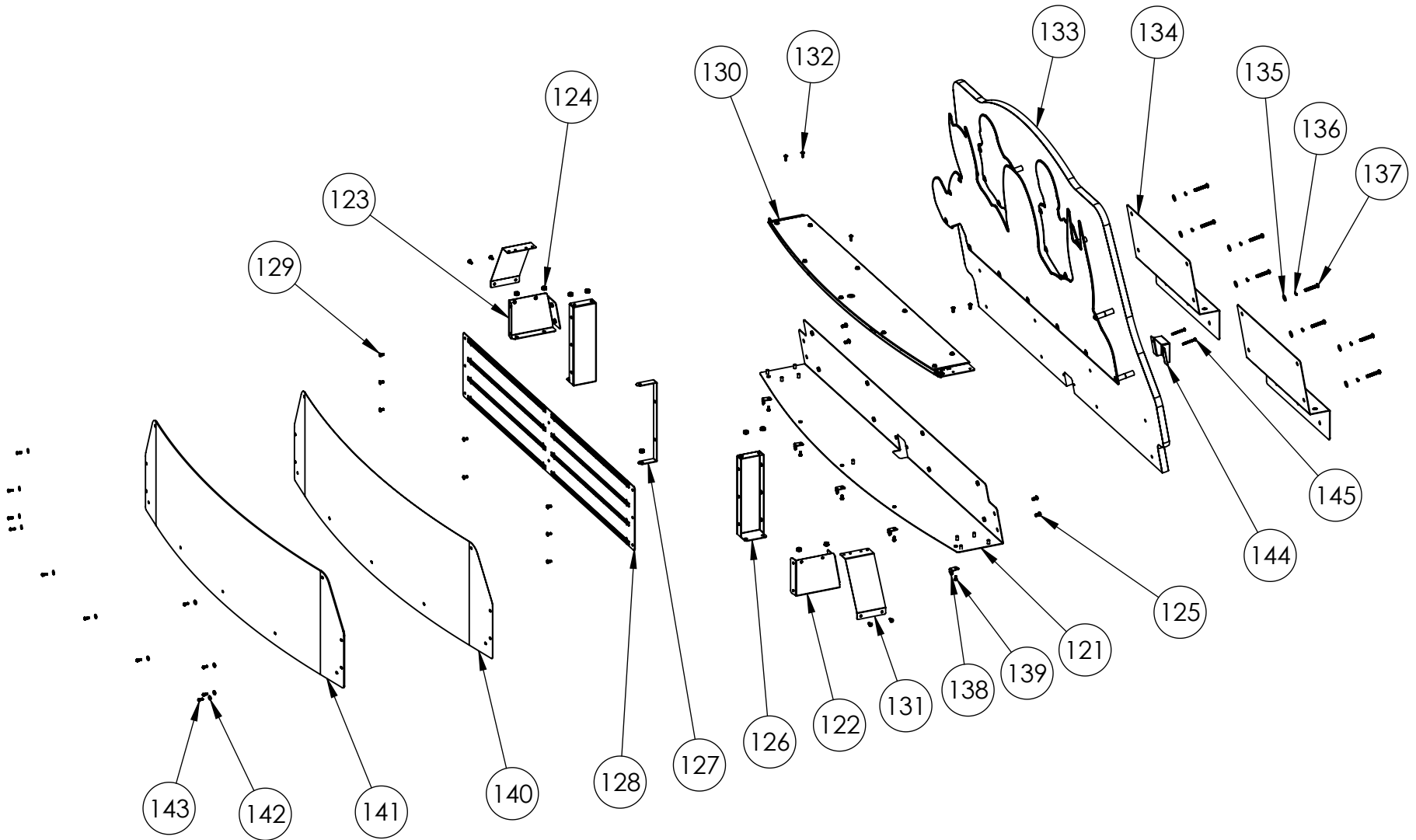

Injustice Arcade (55")
Marquee Sub-Assembly
(BOM on next page)





Injustice Arcade (55") - Marquee Sub-Assembly: BOM

ITEM NO.	PART NUMBER	DESCRIPTION	QTY.
121	600-02067-01	Marquee Base Plate	1
122	600-02065-01	Right Marquee Plate	1
123	600-02066-01	Left Marquee Plate	1
124	McMaster-Carr - 90675A029	Steel Locknut with External-Tooth Lock Washer, Zinc-Plated, 1/4"-20 Thread Size	9
125	McMaster-Carr - 96075A211	Black-Oxide Alloy Steel Tamper-Resistant Torx Rounded Head Screws, 1/4"-20 Thread Size, 1/2" Long	4
126	600-02082-01	Marquee LED Support Bracket	2
127	600-02086-01	Marquee LED Center Support Bracket	1
128	Injustice_55_Marquee_Logo_Backlight_Assy	Logo Marquee LED Sub-Assembly	1
129	McMaster-Carr - 90272A827	Steel Phillips Rounded Head Screws, 10-32 Thread Size, 3/8" Long	8
130	Injustice_55_Marquee_Light_Panel_Assy	Uplighting Marquee LED Sub-Assembly	1
131	600-02088-01	Marquee Side Cap Plate	2
132	McMaster-Carr - 94779A580	18-8 Stainless Steel Phillips Extra-Wide Rounded Head Screws, Black-Oxide, 8-32 Thread Size, 1/2" Long	9
133	Injustice_55_Marquee_Backboard_Assy	Character Backboard Assembly	1
134	600-02087-01	Marquee Mounting Bracket	2
135	McMaster-Carr - 97416A119	Black-Oxide Steel SAE Flat Washer for 1/4" Screw Size, 0.281" ID, 0.625" OD	8
136	McMaster-Carr - 93711A500	Black-Oxide 18-8 Stainless Steel Split Lock Washer for 1/4" Socket Head Screws, 0.26" ID, 0.363" OD	8
137	McMaster-Carr - 96075A231	Black-Oxide Alloy Steel Tamper-Resistant Torx Rounded Head Screws, 1/4"-20 Thread Size, 1-1/2" Long	8
138	600-01434-01	Marquee Top/Bottom Bracket	5
139	McMaster-Carr - 90316A192	Stainless Steel Flanged Hex Head Screws with Slotted Drive, 8-32 Thread Size, 3/8" Long	5
140	606-01364-01	Marquee Translite	1
141	600-02085-01	Marquee Lens PETG	1
142	McMaster-Carr - 97416A113	Black-Oxide Steel SAE Washer for Number 8 Screw Size, 0.188" ID, 0.438" OD	11
143	McMaster-Carr - 96075A139	Black-Oxide Alloy Steel Tamper-Resistant Torx Rounded Head Screws, 8-32 Thread Size, 1/2" Long	11
144	600-02089-01	Marquee Harness Plate	1
145	McMaster-Carr - 96075A155	Black-Oxide Alloy Steel Tamper-Resistant Torx Rounded Head Screws, 8-32 Thread Size, 1-1/2" Long	2

ITEM NO.	PART NUMBER	DESCRIPTION	QTY.
146	600-02081-01	Logo LED Panel	1
147	500-00162-01 (50 CM)	White Flexible LED Tape, w/ FOAM	8

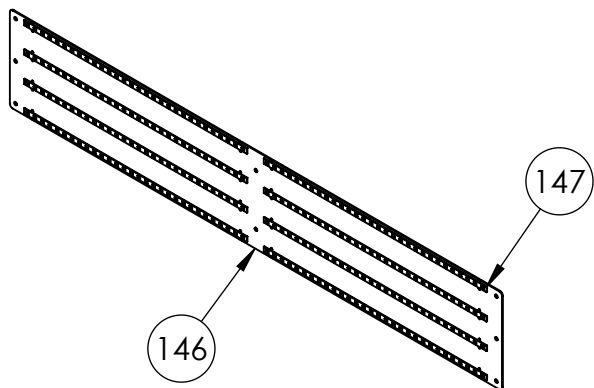

Injustice Arcade (55") Logo Marquee LED Sub-Assembly



ITEM NO.	PART NUMBER	DESCRIPTION	QTY.
148	600-02083-01	Marquee LED Panel	1
149	500-00162-01 (50 CM)	White Flexible LED Tape, w/ FOAM	4
150	500-00162-01 (45 CM)	White Flexible LED Tape, w/ FOAM	2
151	500-00162-01 (35 CM)	White Flexible LED Tape, w/ FOAM	2
152	500-00162-01 (20 CM)	White Flexible LED Tape, w/ FOAM	2
153	McMaster-Carr - 94639A289	Nylon Unthreaded Spacers, 1/4" OD, 5/16" Length, for Number 8 Screw Size	9
154	600-02084-01	Marquee LED Lens PETG	1
155	McMaster-Carr - 90126A009	Zinc-Plated Steel SAE Washer for Number 8 Screw Size, 0.188" ID, 0.438" OD	9
156	McMaster-Carr - 90316A197	Stainless Steel Flanged Hex Head Screws with Slotted Drive, 8-32 Thread Size, 3/4" Long	9
157	McMaster-Carr - 90675A009	Steel Locknut with External-Tooth Lock Washer, Zinc-Plated, 8-32 Thread Size, 1 1/32" Wide	11
158	600-01434-01	Marquee Top/Bottom Bracket	2
159	McMaster-Carr - 90316A194	Stainless Steel Flanged Hex Head Screws with Slotted Drive, 8-32 Thread Size, 1/2" Long	2

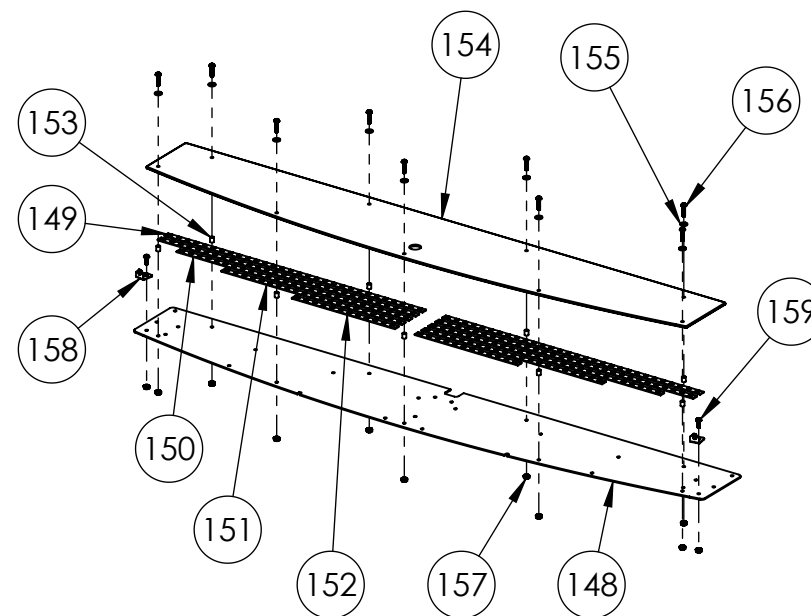

Injustice Arcade (55") Uplighting Marquee LED Sub-Assembly

ITEM NO.	PART NUMBER	DESCRIPTION	QTY.
160	601-00812-01	Marquee Panel	1
161	600-02075-01	Cyborg Panel	1
162	606-01360-01	Cyborg Decal	1
163	600-02076-01	Aquaman Panel	1
164	606-01361-01	Aquaman Decal	1
165	McMaster-Carr - 94639A506	Nylon Unthreaded Spacers, 1/2" OD, 1" Length, for 1/4" Screw Size	30
166	McMaster-Carr - 97416A119	Black-Oxide Steel SAE Flat Washer for 1/4" Screw Size, 0.281" ID, 0.625" OD	20
167	McMaster-Carr - 91255A545	Hex Drive Rounded Head Screw, Black-Oxide Alloy Steel, 1/4"-20 Thread Size, 2" Long	10
168	600-02074-01	Superhero Trio Panel	1
169	606-01359-01	Superhero Trio Decal	1
170	McMaster-Carr - 91255A549	Hex Drive Rounded Head Screw, Black-Oxide Alloy Steel, 1/4"-20 Thread Size, 3" Long	10

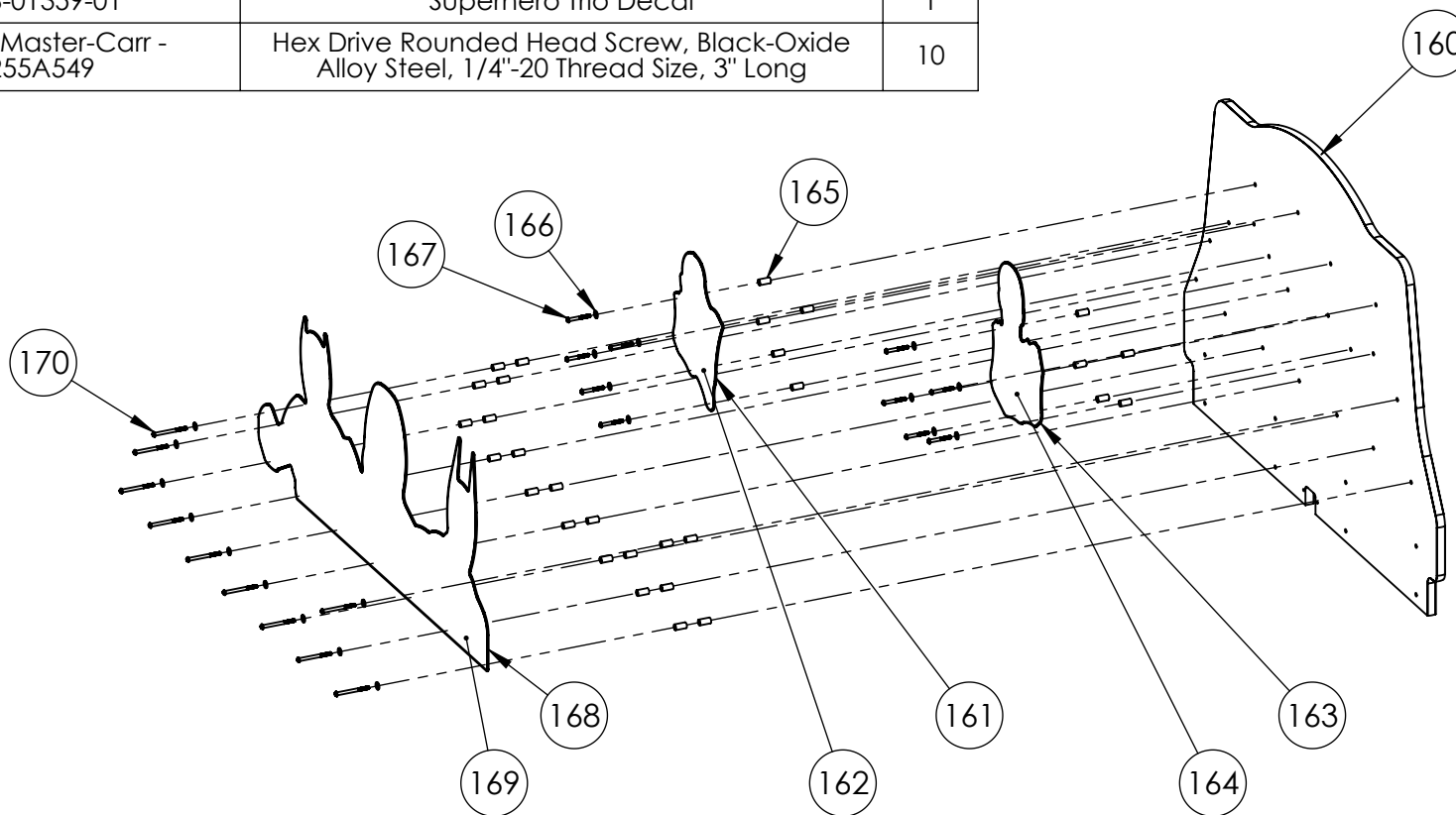

Injustice Arcade (55")
Character Backboard Assembly



ITEM NO.	PART NUMBER	DESCRIPTION	QTY.
171	606-01352-01	Right Side Panel Decal	1
172	606-01353-01	Left Side Panel Decal	1
173	606-01354-01	Front Panel Decal	1
174	606-01355-01	Front Right Decal	1
175	606-01356-01	Front Left Decal	1
176	606-01362-01	Control Panel Decal	1
177	606-01363-01	Speaker Panel Decal	1
178	606-01357-01	Marquee Background Decal	1

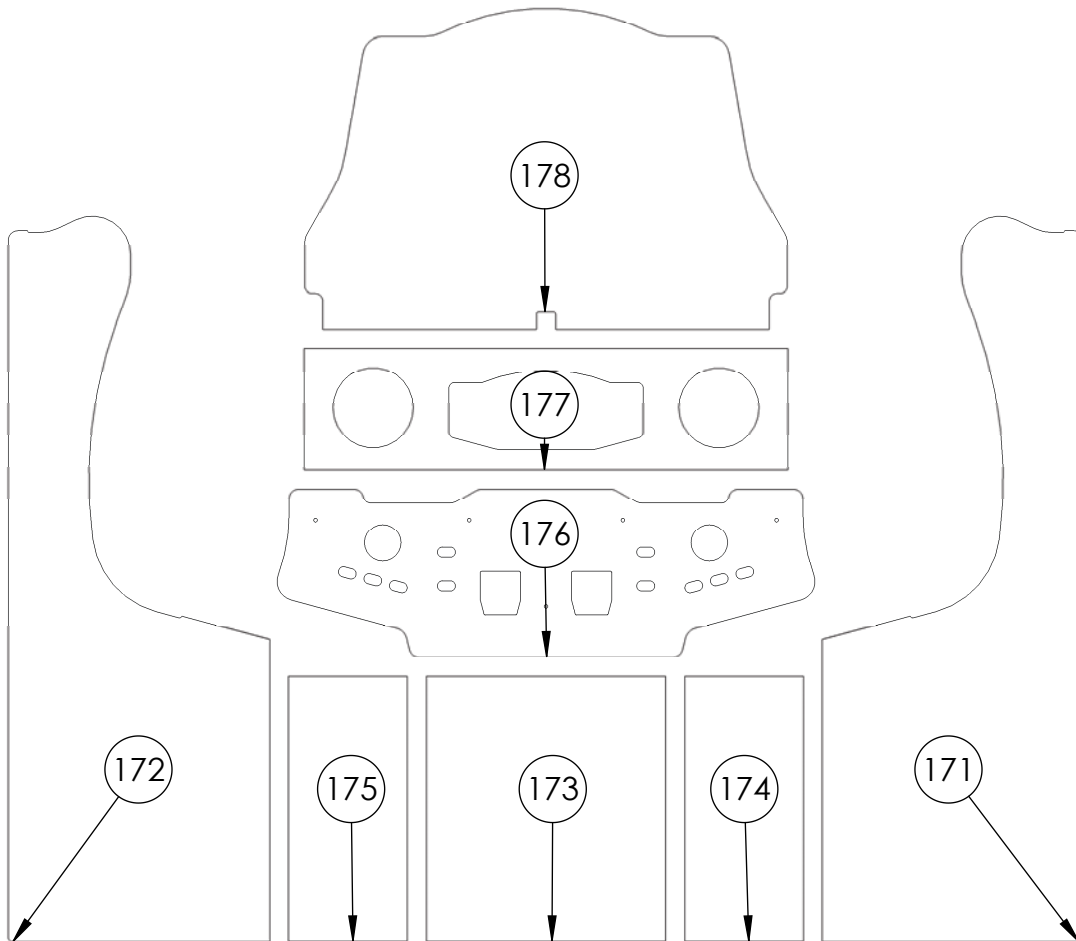

Injustice Arcade (55")
Cabinet Decals



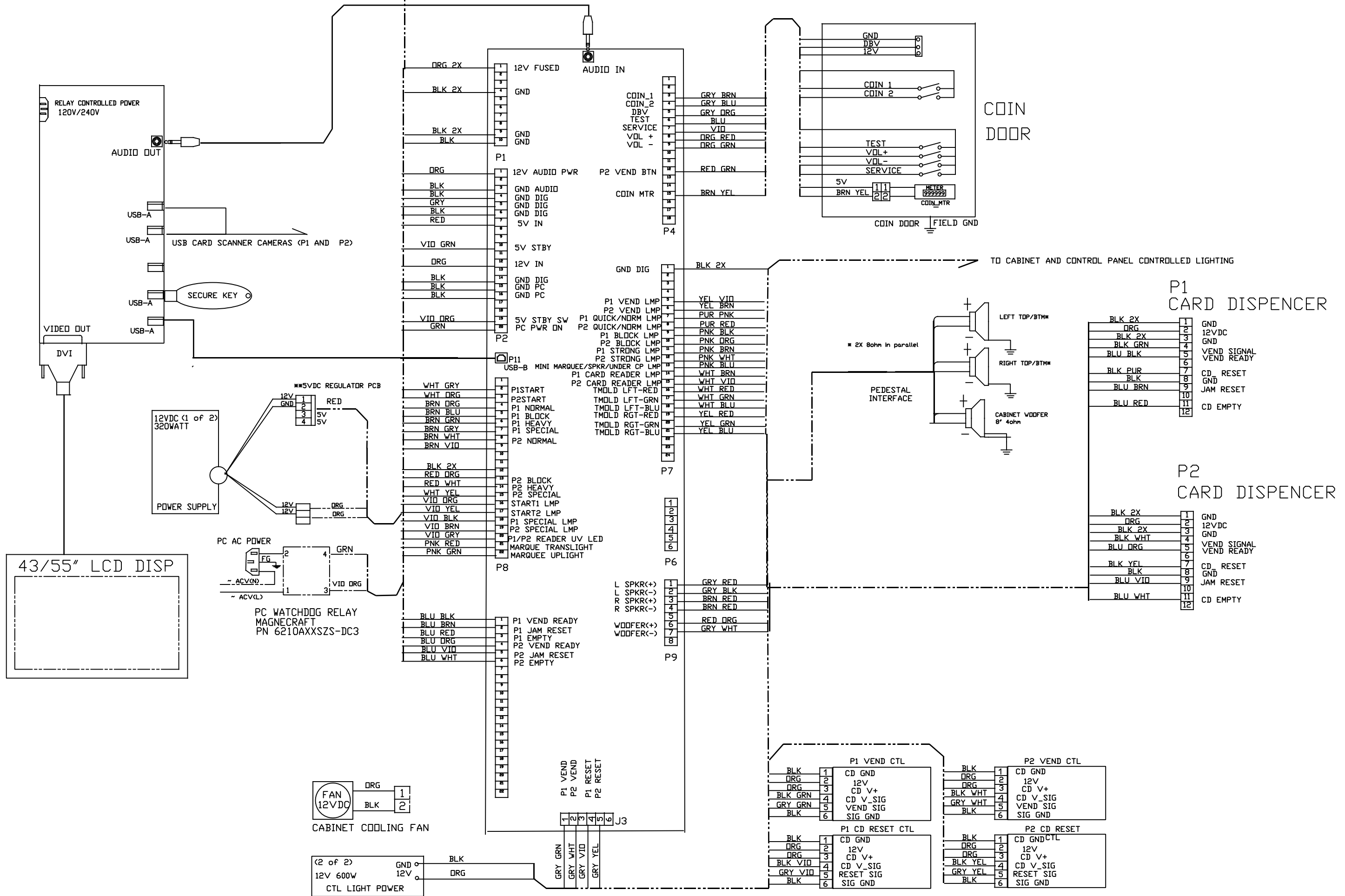

NOTE: FOR CONTINUED SAFETY USE ONLY SPECIFIED FUSE RATING.