

NERF™ Arcade Operator's Manual



This Page Left
Blank
Intentionally

NERF™ Arcade

Table of Contents

Safety	5
Operation	5
Transporting.....	5
Handling Components	5
Disconnect Power	5
Grounding	5
Electrical Shocks.....	5
Monitor	5
Power Cord	5
Surge Suppressor	5
Water and Other Liquid Sources.....	6
Connectors	6
Computer	6
Hazard to Epileptics	6
Manual	6
Specifications	6
Product Specifications	7
Electrical Power	7
Temperature	7
Humidity.....	7
Dimensions.....	7
Fuse Replacement Guide	7
Setup	8
Unpack Materials	8
Cabinet Assembly Instructions.....	9
Samsung Monitor Settings.....	21
SAMSUNG MONITOR SETTINGS	22
Card Reader Installation and Setup	23
Check Electrical Settings	24
Startup Game	24

NERF™ Arcade

Diagnostic and Adjustments	25
Basic Functional Test on Initial Power Up.....	26
Test Menus.....	27
Main Menu.....	27
Diagnostics	28
Pricing and Payout Adjustments (Cash)	29
Pricing and Payout Adjustments (Tokens)	30
Pricing and Payout Adjustments (Swipes)	31
Game Settings	32
System Settings	33
Audits	34
Resets.....	35
Volume	36
Calibration.....	37
Utilities	38
System Information.....	39
Choosing the Right Pricing Adjustments for Your Location	40
PC Hardware	41
PC Hard Drive Recovery	42
Troubleshooting	43
Technical Support	47
Electrical and Mechanical Illustrations	48

NERF™ Arcade

Safety

Operation

Before operating game, read this manual. Failure to properly install and operate this game could result in malfunction or accident. Operate the game in accordance with the manual.

Transporting

The cabinet is very heavy. Because the monitor is high, the cabinet is also very top-heavy. Use appropriate care when moving or transporting cabinet. It contains fragile glass and electronic components. Avoid rough handling.

Handling Components

Many components are extremely sensitive to handling, environmental and Electrostatic Discharge (ESD) events—especially the computer. Do not handle it roughly. Before servicing, call your distributor and inquire about the PC warranty. Use proper ESD procedures when servicing. Protect components from harmful environmental conditions, such as extreme temperatures, excessive moisture or other damaging effects.

Disconnect Power

Always turn the power off and unplug the unit before servicing or making adjustments unless otherwise instructed. Installing or repairing components while power is on can damage the components and void the warranty.

Grounding

Avoid electrical shock. Do not plug in AC power until you have inspected and properly grounded the unit. Only plug into a grounded, three-wire outlet. Do not use a “cheater” plug or cut off the ground pin on the line cord.

Electrical Shocks

There is no isolation transformer in the cabinet. Disconnect AC power before servicing. However, be aware that lethal voltages can remain in the electronic components even when AC power is disconnected. Use extreme caution when servicing. Verify that there is a working ground connection. If the unit sustains water damage, cease using it immediately and unplug AC power.

Monitor

The monitor contains no user serviceable parts. Do not attempt to service the monitor.

Power Cord

If the power cord is damaged or lost, replace it with an identical cord as supplied by the manufacturer or an authorized service agent.

Surge Suppressor

It is recommended that you plug your game’s power cord into a surge suppressor to help protect from power surges that may damage sensitive electronic components.

NERF™ Arcade

Water and Other Liquid Sources

Do not install game near sprinkler or other water jet sources. Do not use water jet to clean game. Keep minimum clearance behind game and wall for proper ventilation but also prevent access of liquid from spills and sprays from entering ventilation holes.

Connectors

When servicing machine, ensure all connectors mate properly. If connectors do not slip in easily, do not force them. Connectors are often keyed and only connect one way. Check for correct orientation.

Computer

The computer contains sensitive components, including a hard drive. Do not handle it roughly. Call your distributor before servicing its internal components. Ask about warranty information as it relates to the PC. Cycle AC power on or off with the cabinet power switch.

A dongle has been inserted into one of the USB ports. This is required for game play.

Do not remove the dongle except for troubleshooting purposes.

Hazard to Epileptics

A small portion of the population has an epileptic condition that may cause seizures. Affected persons experience seizures while watching some television pictures or playing certain video games. People who have not had seizures may still have an undetected epileptic condition. If anyone in your family has experienced epilepsy symptoms (seizures or loss of awareness), consult your physical before using video games. While children play video games, a parent should observe. Be alert to the following symptoms: dizziness, altered vision, eye or muscle twitching, involuntary movements, loss of awareness, disorientation or convulsions. If you or your child experiences these symptoms, discontinue use immediately and consult your physician.

Manual

Keep this manual available and ready for use. If the game fails to function properly, turn off the machine and unplug the AC line cord. Contact your local distributor. You may not reproduce this document or any of its contents without written authorization from Raw Thrills, Inc.

Specifications

For reasons such as performance, this product's specifications may change without notice. Federal patent, copyright and other intellectual property laws protect the content, devices and design of the game and its equipment.

NERF™ Arcade

Product Specifications

Electrical Power

United States, International and Japan

Operating AC Current: 5/2.5 Amps

Voltage: 115/230~VAC 50/60Hz

Temperature

50° F to 104° F

(10° C to 40° C)

Humidity

Must not exceed 95% relative humidity

Dimensions

Assembled

Height: 90.00" (2.29 meters)

Width: 61.75" (1.57 meters)

Depth: 94.00" – 106.00" (2.39 meters – 2.69 meters) – **SUGGESTED RANGE**

Fuse Replacement Guide

NOTE: FOR CONTINUED PROTECTION AGAINST
FIRE AND ELECTRICAL DAMAGE, USE ONLY
SPECIFIED FUSE TYPE AND VALUE.

Please see unit for specified fuse labeling. Abbreviations:

5A 250V	5A, 250VAC Fast Acting 3AG Fuse	Littlefuse 0312005.MXP (or equivalent)
5A-SB 250V	5A, 250VAC Slow Blow 3AG Fuse	Littlefuse 0313005.HXP (or equivalent)
2A-SB 250V	2A, 250VAC Slow Blow 3AG Fuse	Littlefuse 0313002.HXP (or equivalent)

NERF™ Arcade

Setup

Unpack Materials

1. Place the shipping crate(s) on a flat, stable surface.
2. Cut the banding straps and remove the cardboard lids.
3. Lift off the large cardboard containers surrounding the control cabinet (GUNS), pedestal cabinet (SEATS), and LCD stand components pallet and remove any shipping cleats.
4. Remove the coin door key from the coin return slot.
5. Open the top coin door.
6. Locate the keys for the back door and the cash box door.
7. Open the cash box door and remove the cash box.
8. Check for shipping damage to the following:
 - Cabinet decals
 - Monitor and stand
 - Marquee
 - Lower signs
9. Check the AC line cord for visible signs of damage.

Pay particular attention to the plug and line cord insulation.

For video instructions and latest information please visit:



NERF Arcade Game Page
rawthrills.com/nerf-arcade/

NERF Arcade Full Assembly Video
youtu.be/C-6vHsMgBjk



NERF Arcade – Replacing a Side-to-Side Potentiometer Video
youtu.be/8AGiy0LjIw8

NERF Arcade – Replacing a Side-to-Side Stop Video
youtu.be/S3Op7Z8Hwuk



NERF Arcade – Replacing an Up/Down Potentiometer Video
youtu.be/eO9afzAdQGw

NERF™ Arcade

Cabinet Assembly Instructions

Game POWER should be OFF until further directed.

Required Tools:

- Ladder (6 ft minimum) – EXERCISE CAUTION WHILE ON LADDER
- Socket Wrench or Nut Driver: 3/8", 7/16", 13mm
- Drill and Bit or Screwdriver: Pin-in Torx (T25, T27), Phillips, Slotted

Build Universal LCD Stand Assembly (TWO PEOPLE REQUIRED)

Attach Horizontal Bracket of Universal Mount to Upper Half of Universal LCD Stand with (4) 1/4"-20 x 3" Black Oxide Hex Head Screws and securing with (4) Flat Washers and (4) Nylon-Insert Lock Nuts as shown below, using 3/8" & 7/16" Nut Drivers (or Socket Wrenches). Be sure to use the specific holes noted for NERF™ Arcade approved commercial grade 65" monitors (Samsung QB65N or QB65R).

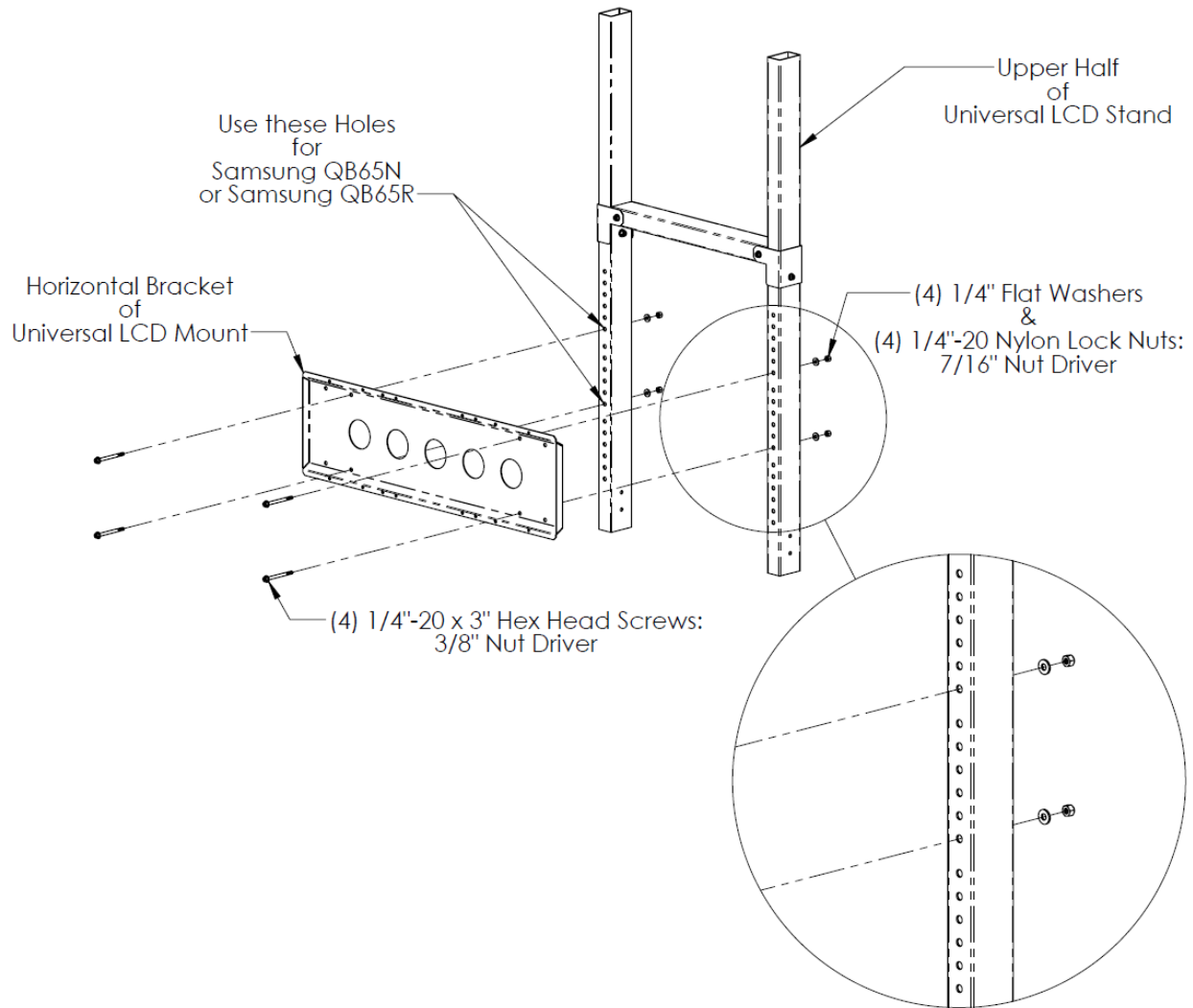

Figure A – Attach Horizontal Mount Bracket to Upper Half of LCD Stand

NERF™ Arcade

Locate Lower Half of Universal LCD Stand and place in final desired location (final assembly will be very heavy and **difficult to move**). The following hardware is already installed on Lower Half's Tube Joiner brackets and must be removed to attach the Top Half to the Lower Half: (4) 1/4"-20 x 2" Black Oxide Hex Head Screws, (4) Flat Washers, and (4) Nylon-Insert Lock Nuts. Remove hardware using (2) 7/16" Nut Drivers, then re-use to assemble Upper and Lower Halves as shown below.

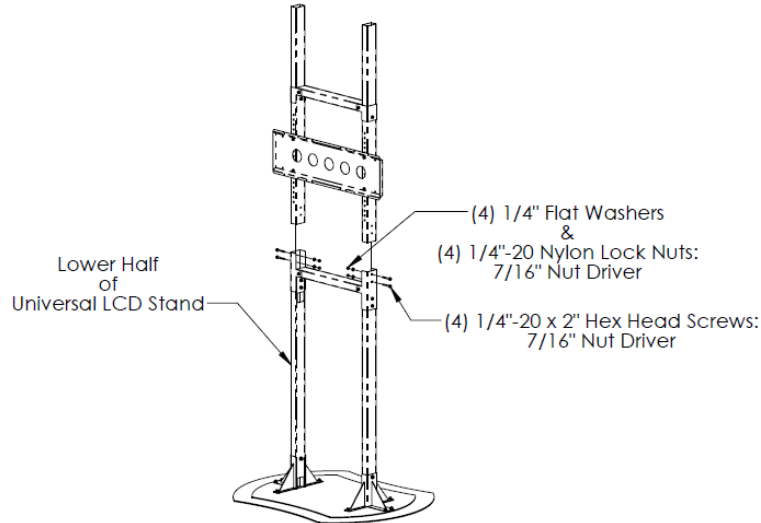

Figure B - Attach Upper and Lower Halves of LCD Stand

Locate (2) Vertical Brackets of Universal Mount, (1) Samsung QB65N/R Commercial Grade 65" Monitor, (4) Samsung supplied VESA Spacers, and the following hardware: (4) M8x1.25mm x 45mm Zinc Hex Head Screws and (4) 5/16" Flat Washers.

NOTE: (2) small Securing Clips will be attached to Vertical Brackets with (2) 10-32 x 1/2" Flanged Hex Head Screws each. Remove these clips at this step for easier Monitor mounting (use 5/16" Nut Driver or Slotted Screwdriver); clips will be reattached in subsequent step. **CAUTION: Be careful not to drop Monitor or let it fall before fully mounting; a second person is required for lifting.**

Install Vertical Brackets onto VESA mounts on Samsung QB65N/R, using supplied spacers and hardware through the 3rd highest hole and lowest slot channel as shown below, using 13mm Nut Driver.

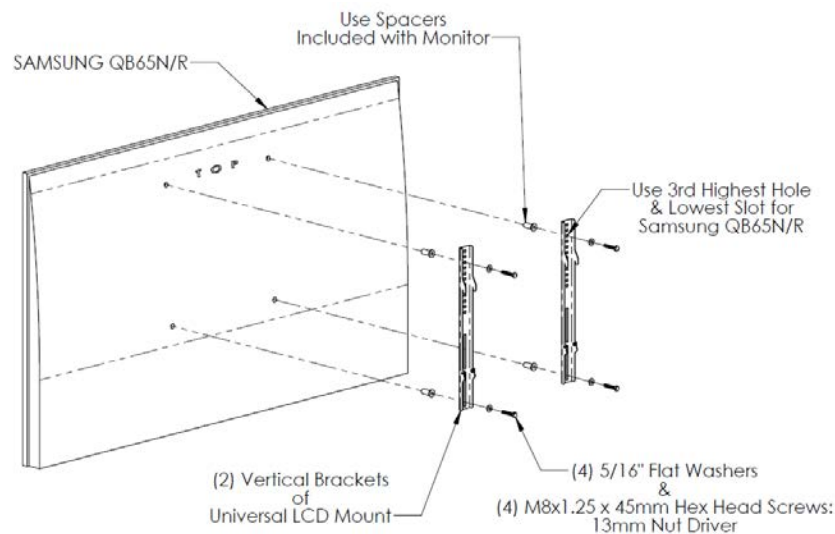

Figure C - Attach Vertical Brackets to Monitor

NERF™ Arcade

Lift and hang Monitor onto Stand such that the Vertical Brackets hook onto top edge of Horizontal Bracket. From the back of Stand, center the Monitor using symmetrically centered holes for reference. Once centered, re-install previously mentioned Securing Clips using 5/16" Nut Driver or Slotted Screwdriver. There are (6) screws total that need to be fully tightened to properly mount Securing Clips and secure Monitor in place.

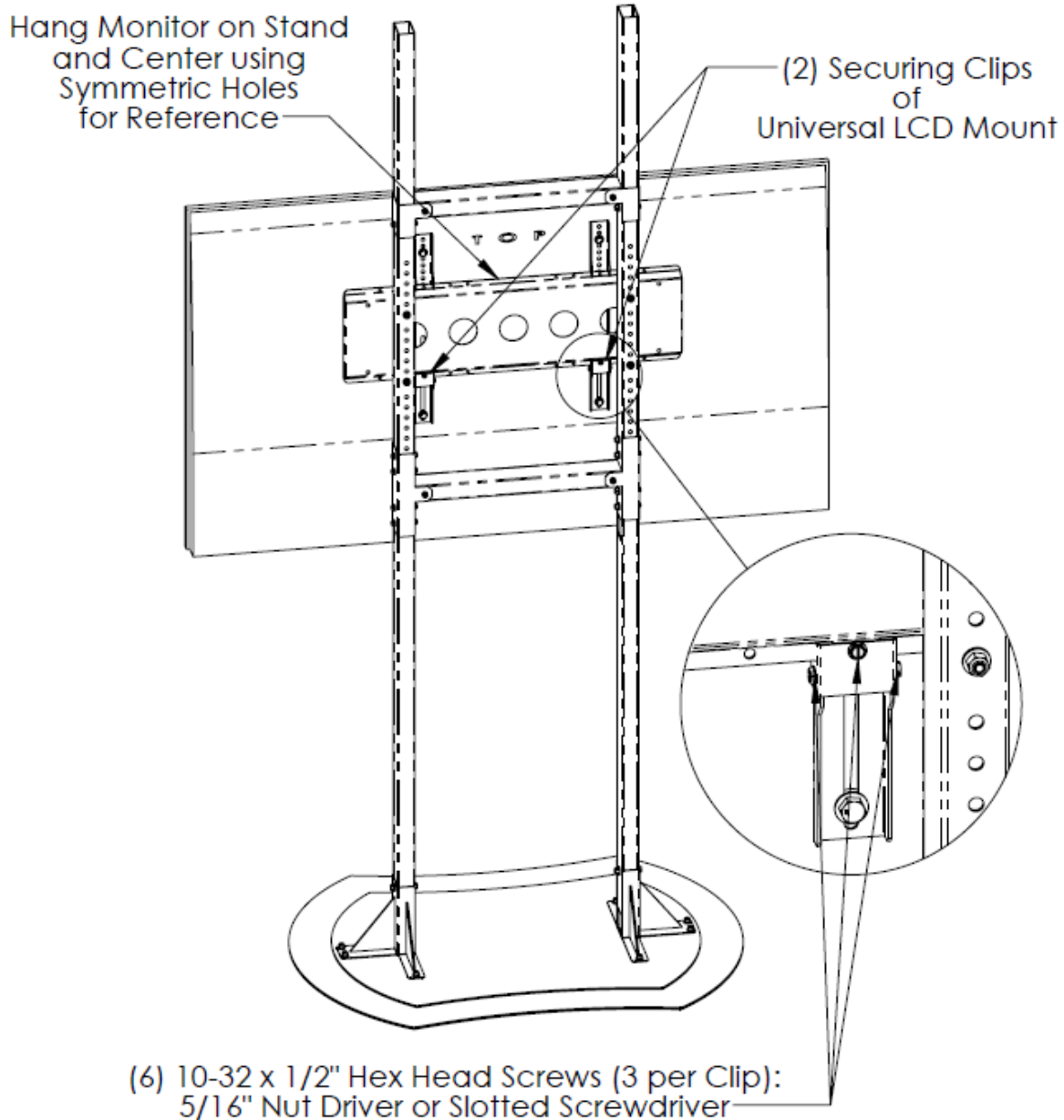

Figure D - Hang & Secure Monitor

NERF™ Arcade

Assemble Monitor Bezel (LADDER RECOMMENDED)

Locate (4) Corner Brackets with 2 strips of 3M VHB Tape already attached to (2) inner faces. Remove protective layer on the VHB tape strips and securely attach Corner Brackets to all 4 corners of the Monitor, aligning front flanges of brackets to be flush to Monitor front and firmly pressing brackets into place to get best adhesion to all Monitor sides.

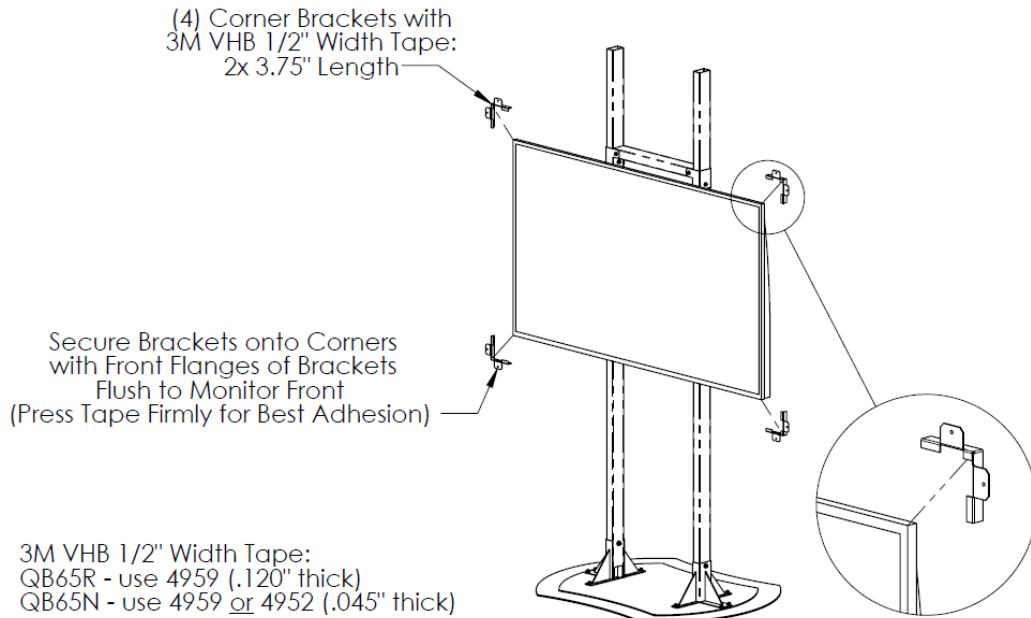

Figure E – Attach Corner Brackets

Locate the following parts: 606-01705-01 (Printed Monitor Bezel Upper Base Panel), 606-01706-01 (Printed Monitor Bezel Right Base Panel), and 606-01707-01 (Printed Monitor Bezel Left Base Panel), in addition to (6) 10-32 x 3/4" Black Oxide Tamperproof Screws and (6) Flat Washers. Attach (3) Panels with (2) sets of screws each to corner brackets as shown below, centering each panel between corner bracket mounting points before tightening screws with Tamper-Resistant T25 Screwdriver.

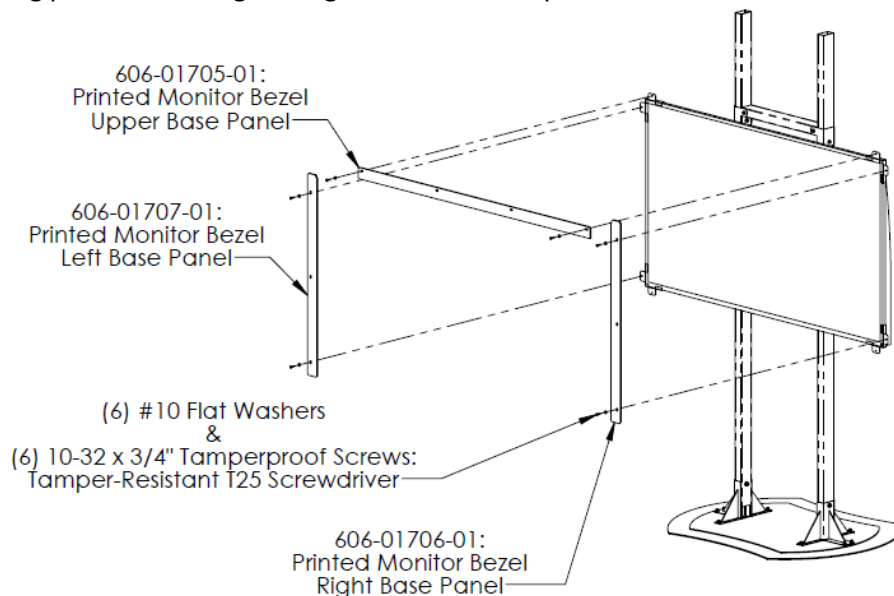

Figure F - Mount Upper and Side Base Panels

NERF™ Arcade

Locate (4) Center Brackets with strip of 3M VHB Tape already attached to inner face. Remove protective layer on the VHB tape strips and securely attach Center Brackets to top and side faces of Monitor where center slots on Base Panels are located, aligning front flanges of brackets to be flush to Monitor front and firmly pressing brackets into place (loosen corner screws as needed). Once Center Brackets are attached to Monitor, install (4) 10-32 x 1/2" Black Oxide Tamperproof Screws and (4) Flat Washers through Base Panels and into Center Brackets.

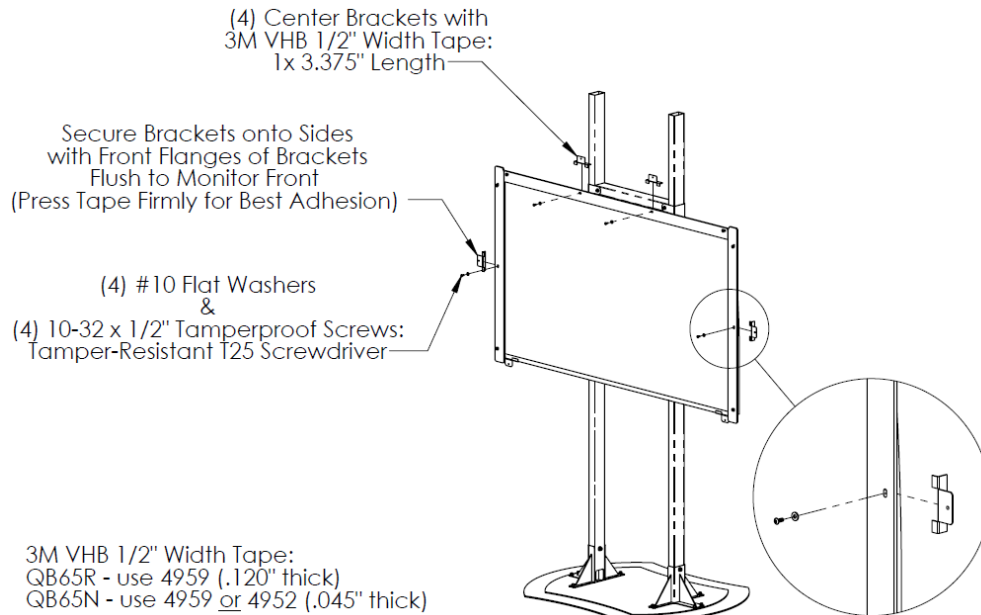

Figure G - Mount Center Brackets for Upper and Side Base Panels

Locate the following parts: 606-01709-01 (Printed Monitor Bezel Upper Right Cap Panel) and 606-01710-01 (Printed Monitor Bezel Upper Left Cap Panel). Using Tamper-Resistant T25 Screwdriver, remove (4) 10-32 x 3/4" Black Oxide Tamperproof Screws and (4) Flat Washers from upper Corner Brackets. Then, install Cap Panels over Base Panels as shown below.

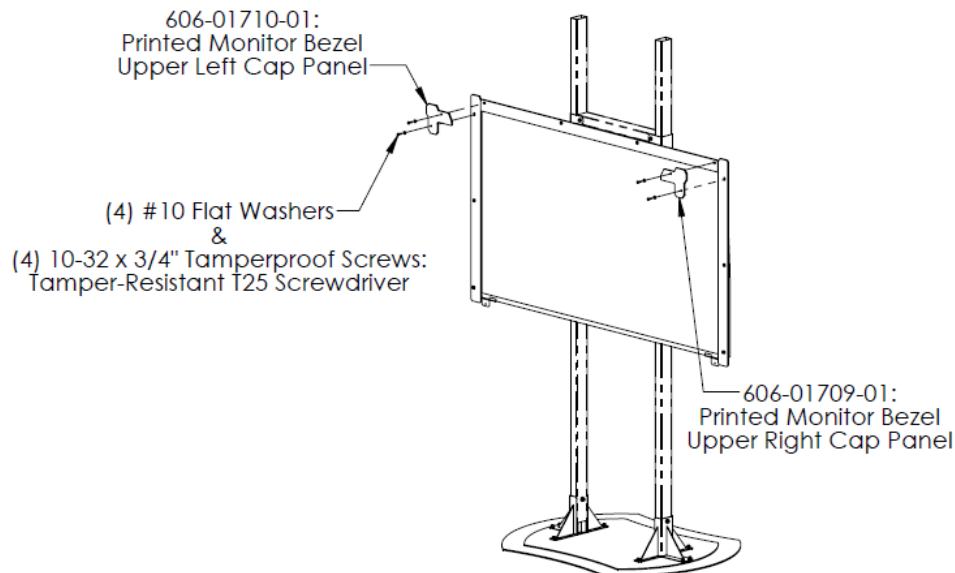

Figure H - Mount Upper Cap Panels

NERF™ Arcade

Locate the following parts to complete Monitor Bezel Assembly: 606-01708-01 (Printed Monitor Bezel Lower Base Panel), 606-01711-01 (Printed Monitor Bezel Lower Right Cap Panel), 606-01712-01 (Printed Monitor Bezel Lower Left Cap Panel), and (2) Center Brackets with strip of 3M VHB Tape already attached to inner face, in addition to (2) 10-32 x 3/4" Black Oxide Tamperproof Screws, (2) 10-32 x 1/2" Black Oxide Tamperproof Screws, and (4) Flat Washers.

Using Tamper-Resistant T25 Screwdriver, remove (2) 10-32 x 3/4" Black Oxide Tamperproof Screws and (2) Flat Washers from lower Corner Brackets. Then, with (2) additional 3/4" screws and washers, install (2) Lower Cap Panels over Lower Base Panel as shown below, leaving screws loose enough to install (2) additional Center Brackets for Lower Base Panel.

Remove protective layer on the VHB tape strips and securely attach (2) Center Brackets to bottom face of Monitor where center slots on Base Panel are located. Align front flanges of brackets to be flush to Monitor front and firmly press brackets into place. Once the Center Brackets are attached to Monitor, install (2) 10-32 x 1/2" Black Oxide Tamperproof Screws and (2) Flat Washers through Lower Base Panel and into Brackets. Tighten all screws to complete Monitor Bezel Assembly.

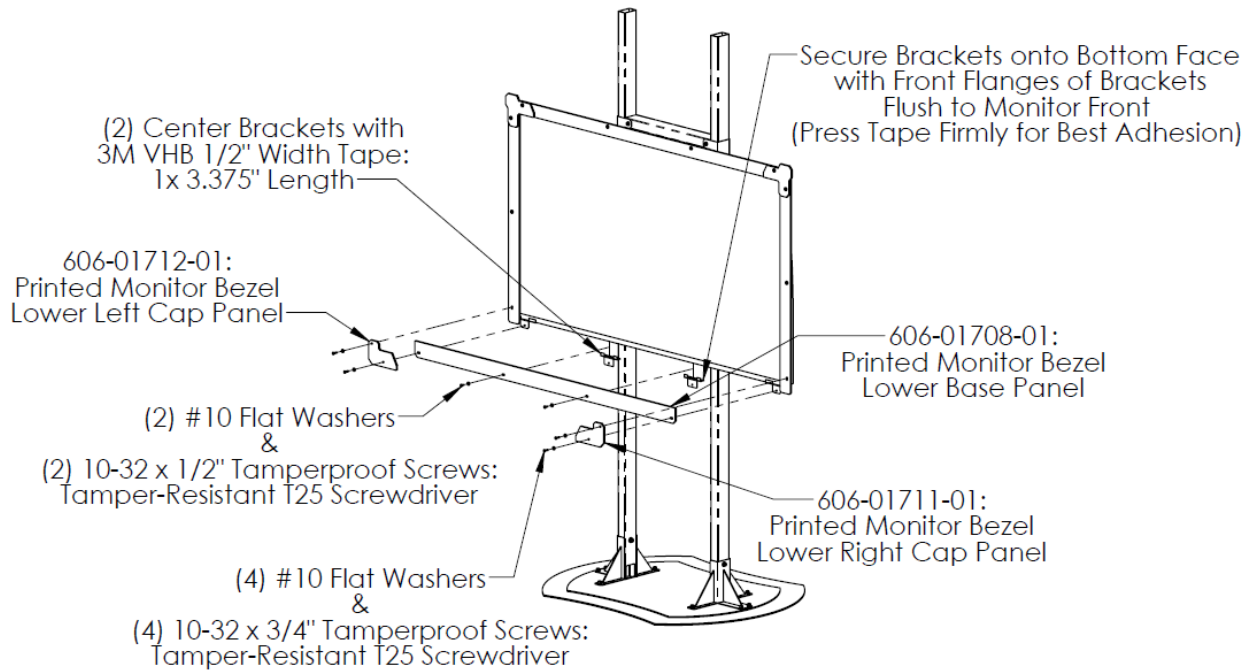

Figure 1 – Complete Monitor Bezel Assembly

NERF™ Arcade

Mount Below Monitor Signage to LCD Stand (TWO PEOPLE RECOMMENDED)

Locate the following parts: Lower Sign Panel (with 606-01703-01 decal) and (2) Cinch Brackets, in addition to (4) 1/4"-20 x 1" Black Oxide Tamperproof Screws, (4) Flat Washers, and (4) Nylon-Insert Lock Nuts. Using Tamper-Resistant T27 Screwdriver and 7/16 Nut Driver, attach (2) Cinch Brackets to Rear of Lower Sign such that retaining flanges are positioned toward outside edges as shown below.

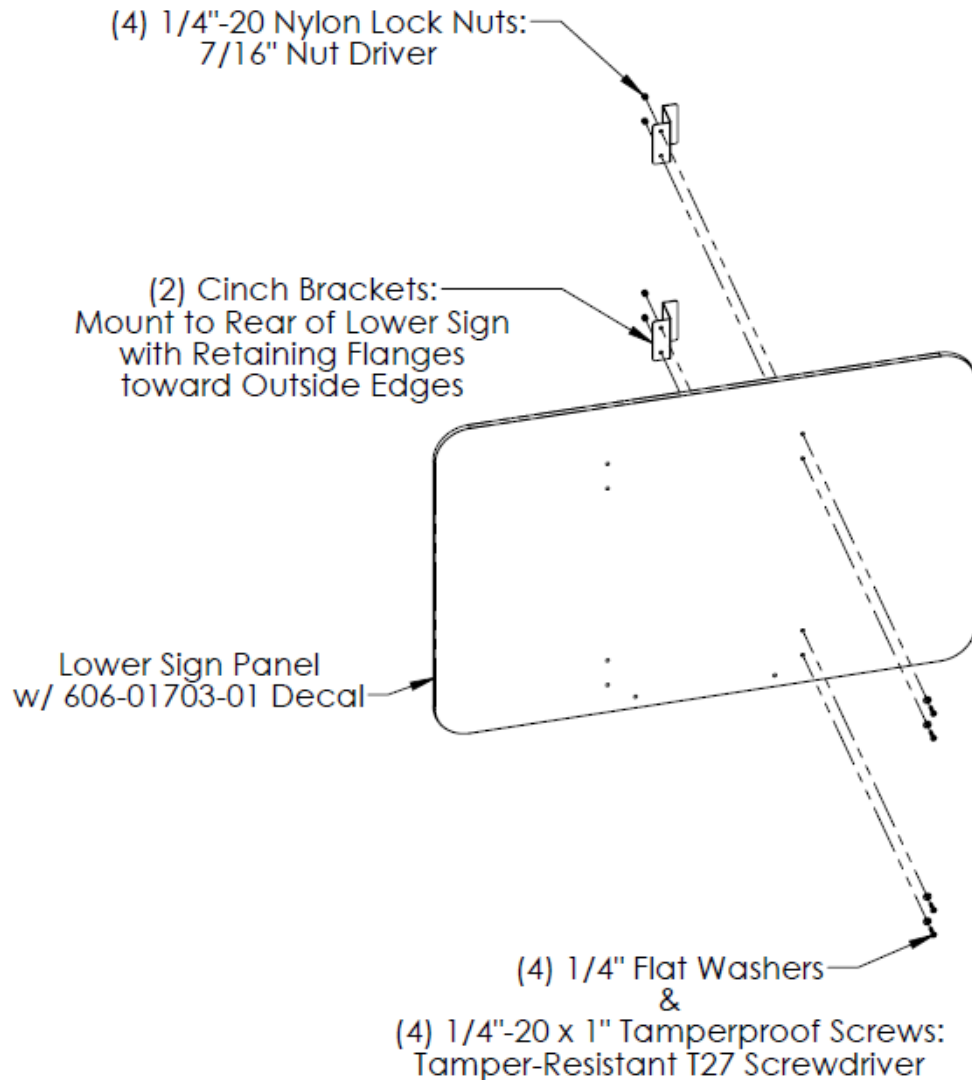

Figure J – Mount (2) Cinch Brackets on Lower Sign Panel

Locate the other (2) Cinch Brackets in addition to (4) 1/4"-20 x 1" Black Oxide Tamperproof Screws, (4) Flat Washers, and (4) Nylon-Insert Lock Nuts. Install Lower Sign with other (2) Cinch Brackets and hardware in between vertical tubes of Lower Half of LCD Stand and above the Welded Tube Supports attached to Stand Base, as shown in figure K. When all (8) screws are properly tightened, the Lower Sign will be secured in place against vertical tubes.

Locate Lower Sign Bracket, (2) 1/4"-20 x 1" Black Oxide Tamperproof Screws, and (2) Flat Washers and install through (2) lowest mounting holes on Lower Sign, using Tamper-Resistant T27 Screwdriver.

NERF™ Arcade

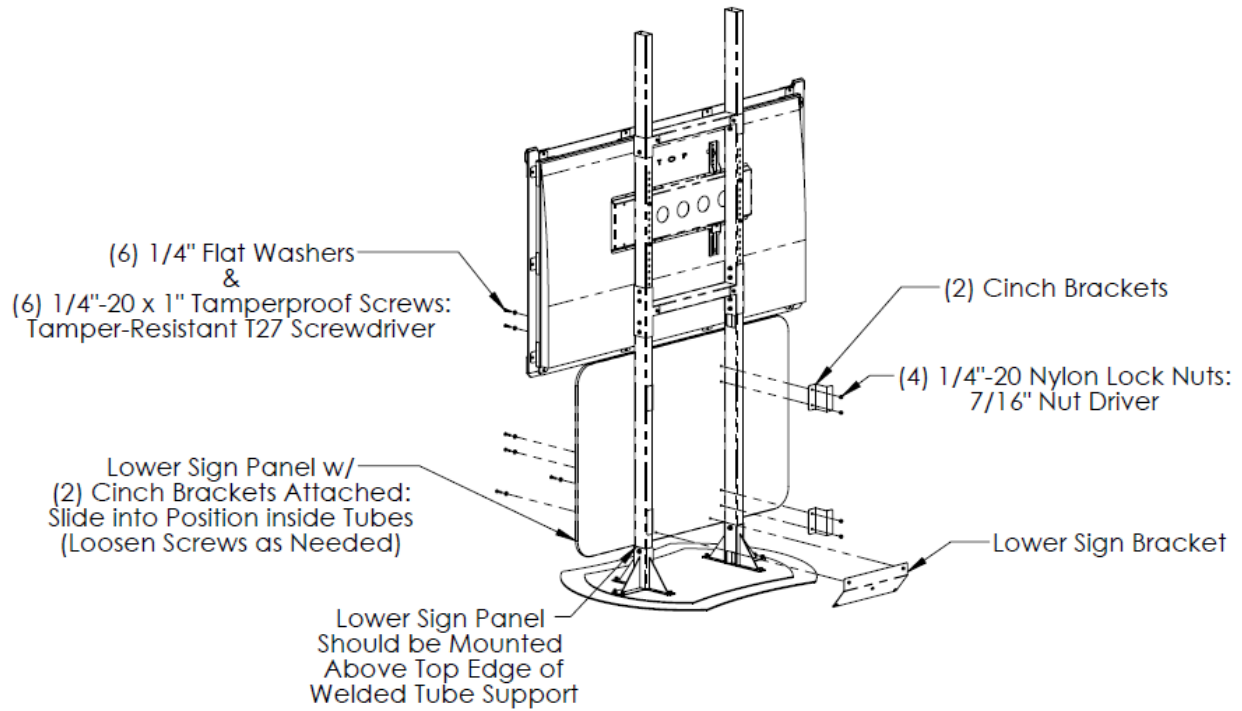

Figure K – Mount Lower Sign Panel and Lower Sign Bracket

Locate Angled Lower Panel (with 606-01704-01 decal) and (3) 1/4"-20 x 1" Black Oxide Tamperproof Screws and (3) Flat Washers. Using Tamper-Resistant T27 Screwdriver, attach Angled Lower Panel with (3) sets of screws to Lower Sign Bracket.

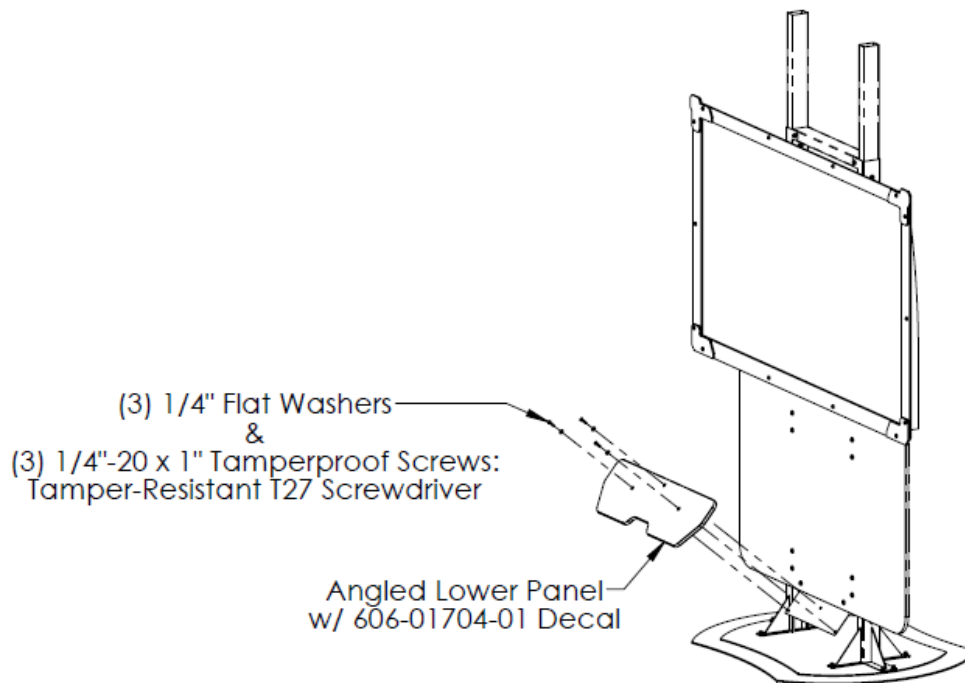

Figure L – Mount Angled Lower Sign Panel

NERF™ Arcade

Mount Marquee Assembly & Connect Marquee Power Supply (TWO PEOPLE AND LADDER REQUIRED)

Locate Marquee Assembly. Setup ladder(s) to lift Marquee up and guide onto vertical tubes of Upper Half of LCD Stand until it rests on Cross Tube, above Monitor and Bezel components. CAUTION: Be careful to not drop Marquee or let assembly fall before fully mounting; a second person is required to help with lifting and stabilizing ladder. (4) 1/4"-20 Nylon-Insert Lock Nuts, that retain (2) Cinch Brackets on Rear of Marquee, can be loosened to allow easier sliding, however, all (4) nuts must be fully tightened (using 7/16" Nut Driver) once Marquee is in place.

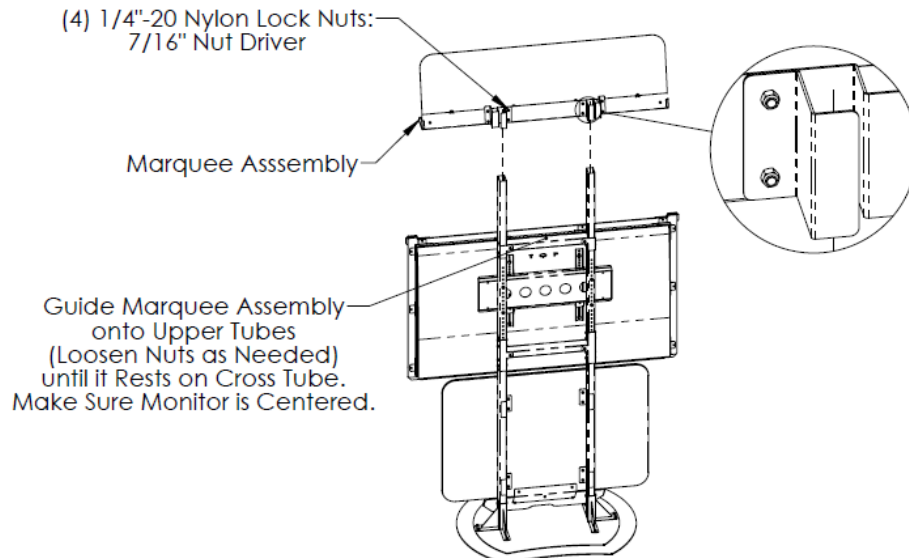

Figure M – Mount Marquee Assembly

Locate Marquee Power Supply and supplemental Line Cord, included with Marquee Assembly, as well as Samsung supplied Line Cord. Using ladder, place Power Supply on Cross Tube using 3M Dual Lock already attached for semi-permanent mounting, and make connection to Panel Mount Connector on bottom face of Marquee. Plug in Line Cord to Power Supply and plug in Samsung supplied Line Cord into inlet on rear of Monitor, but do not plug either cord into power outlet at this time.

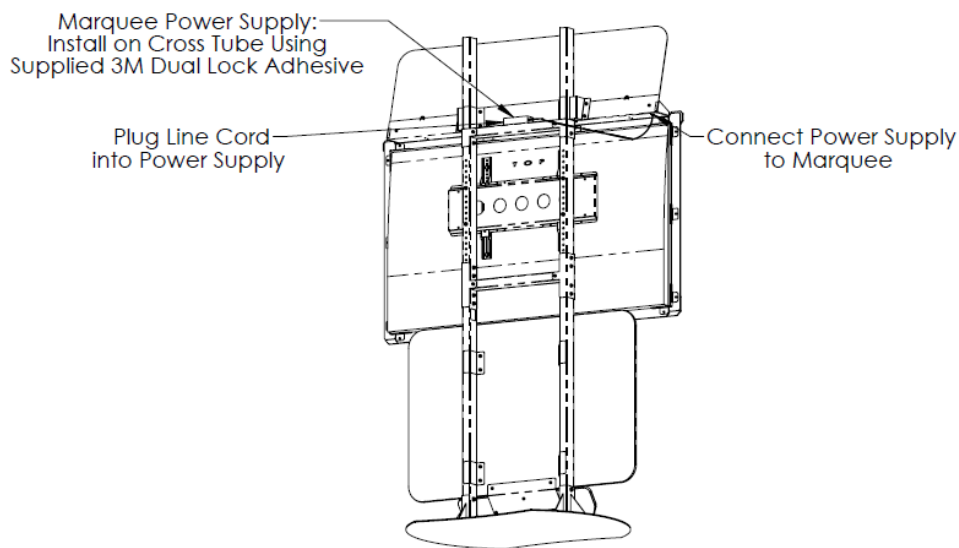

Figure N – Mount Power Supply & Connect to Marquee

NERF™ Arcade

Assemble Cabinet Sections & Complete Setup

Locate and place Control Cabinet (with Guns) in front of completed LCD Stand Assembly. Raw Thrills suggests the depth of the assembled game be in the range of 94"-106". For this range, the distance between the back door of the Control Cabinet and the (larger) Lower Sign Panel should be 17"-29" for reference.

Locate Back Door Key inside Coin Door Vault. Using Phillips Screwdriver, remove (6) screws securing Back Door to Control Cabinet (save for now), open lock with Key, and set Back Door aside (place carefully so that it will not fall).

Locate 36" long Cord Cover, that was packaged on pallet with LCD Stand Components, and Cabinet Line Cord, located in game bag inside Back Door of Cabinet. Install Line Cord and HDMI cable (which is strain-relieved near access hole in base of Cabinet) into the pre-split center channel of Line Cord. Lay Cord Cover centered and flat on floor behind Cabinet and through accessway of Angled Lower Panel. Plug Line Cord into AC Plate inlet, then go to back of LCD Stand and plug HDMI cable into "HDMI IN 1" port on back of Monitor.

NOTE: Tape for securing Cord Cover to floor is not supplied with game due to variety of floor substrates (carpet, tile, wood, etc.) the game will be installed on. It is highly recommended that each location use tape suitable for their location's floor.

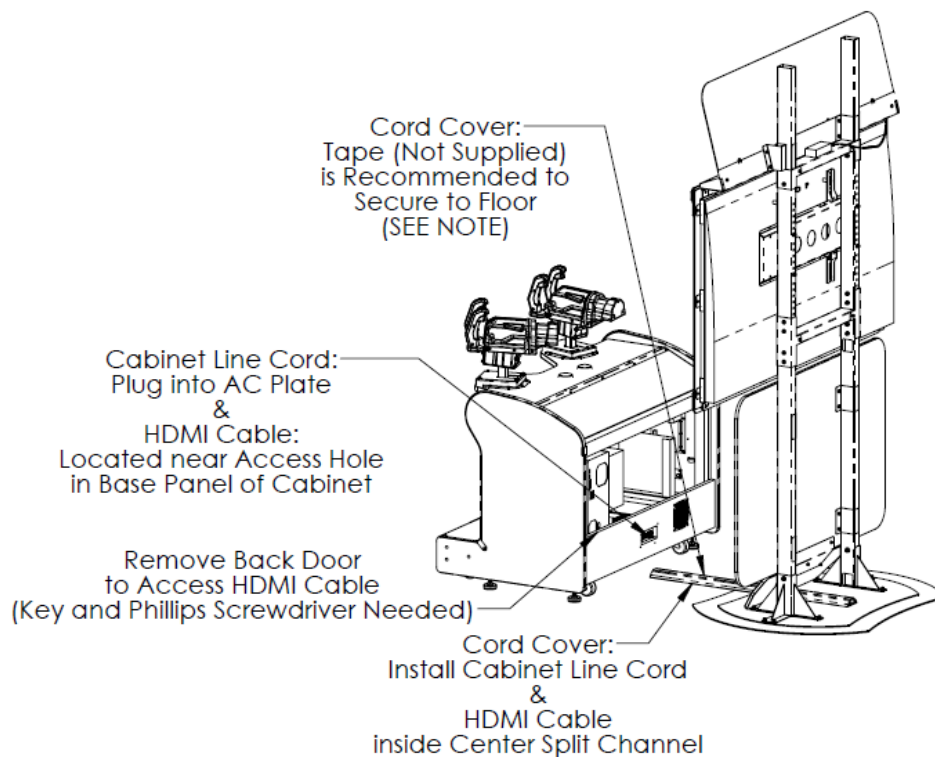

Figure 0 – Place Control Cabinet & Setup Cord Cover

NERF™ Arcade

Locate (2) Cabinet Connect Brackets in addition to (6) 1/4"-20 x 2" Black Oxide Tamperproof Screws, (6) Split-Lock Washers, and (6) Flat Washers. Using Tamper-Resistant T27 Screwdriver, install brackets on inner channels of both sides of Control Cabinet using (6) sets of screws and washers.

Replace Back Door using Key and Lock. (6) #8 x 1-1/4" Wood Screws may be reinstalled at the operator's discretion or simply discarded.

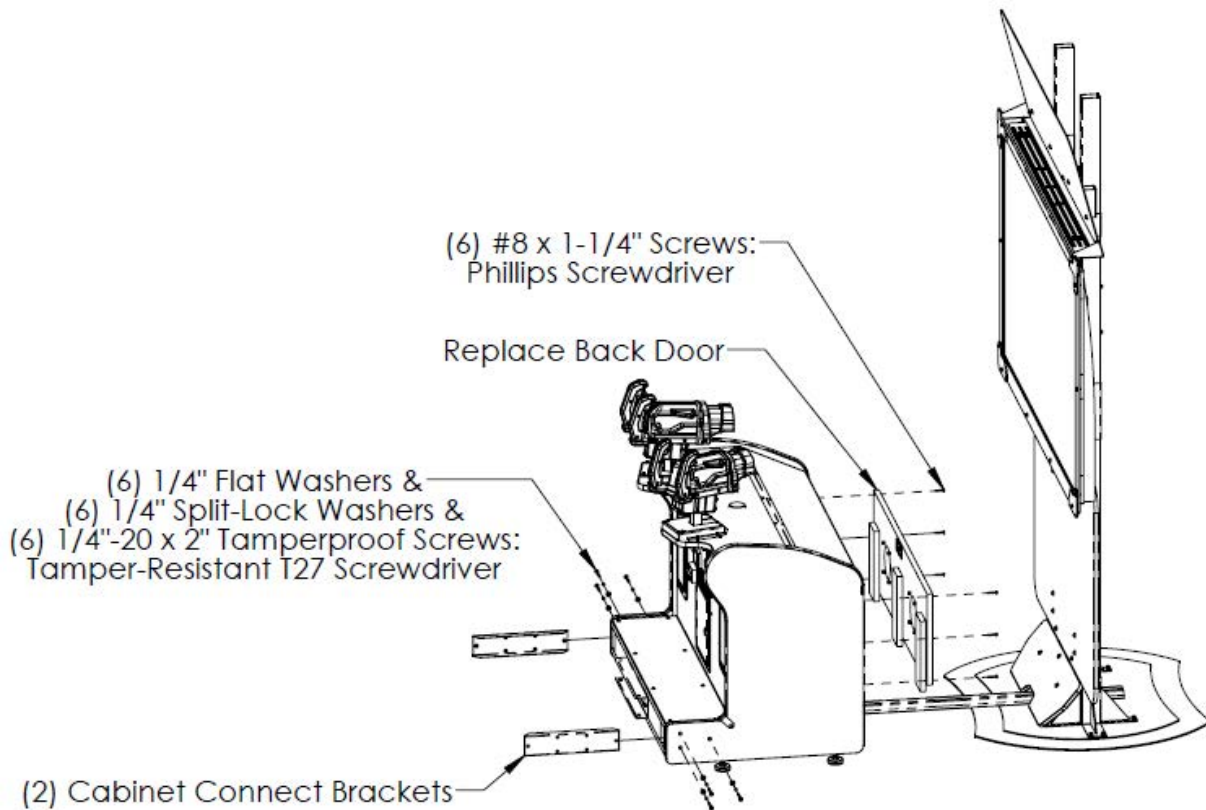

Figure P – Install Cabinet Connect Bracket

Locate and place Pedestal Cabinet (with Seats) in front of Control Cabinet and complete harness connections. Push cabinets together such that Cabinet Connect Brackets slide into channels on Pedestal Cabinet; be sure to not pinch/crush harness.

Locate (6) 1/4"-20 x 2" Black Oxide Tamperproof Screws, (2) 1/4"-20 x 1-1/2" Black Oxide Tamperproof Screws, (8) Split-Lock Washers, and (8) Flat Washers. Using Tamper-Resistant T27 Screwdriver, attach Pedestal Cabinet to Cabinet Connect Brackets using (6) sets of 2" screws and washers. Additionally, using Tamper-Resistant T27 Screwdriver, install remaining (2) sets of 1-1/2" screws and washers through slots in Pedestal Cabinet's tread plate into bracket mounted to the front of Control Cabinet.

NERF™ Arcade

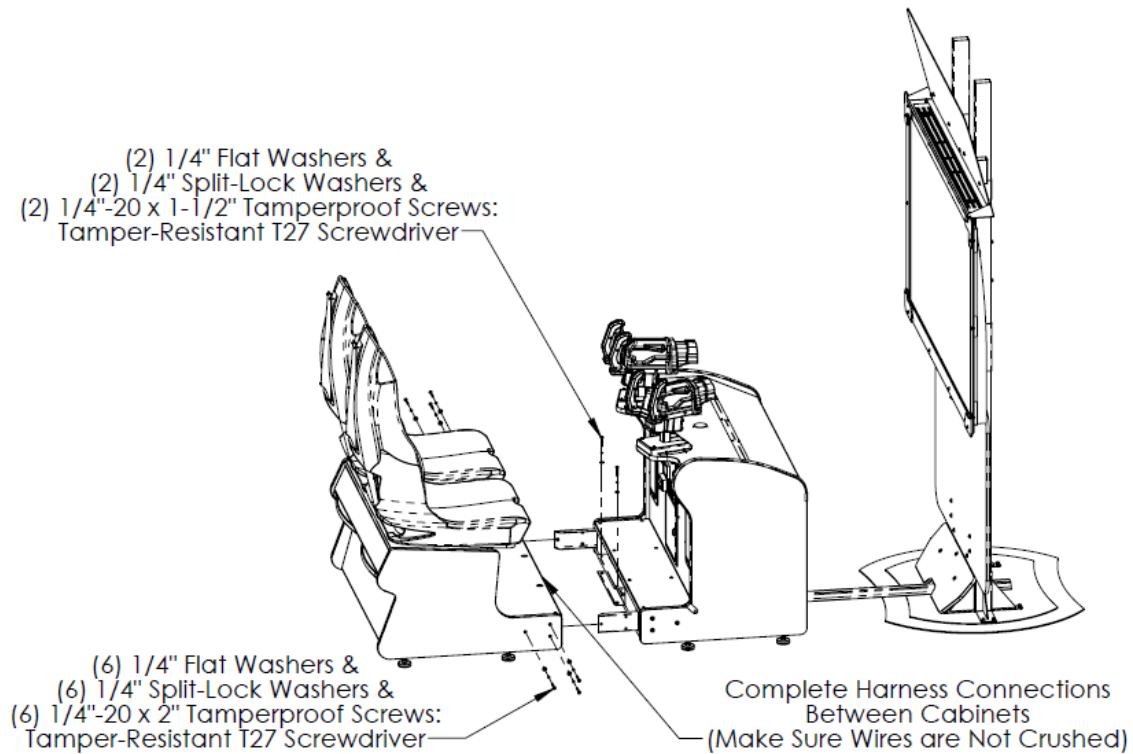

Figure Q – Complete Game Assembly

To finalize assembly, plug in power strip (not included - surge suppressor protection highly recommended) to AC outlet and place behind LCD Stand Assembly. Plug in all (3) power connections to power strip: Main Cabinet, Monitor, and Marquee Power Supply.

NERF™ Arcade

*****IMPORTANT*****

PLEASE FOLLOW INSTRUCTIONS TO SET UP MONITOR

Samsung Monitor Settings

Model #LH65QBNEBGC/GO

STEP 1: Verify game is connected to monitor in HDMI IN 1 at rear of monitor.

STEP 2: Power on GAME cabinet and MONITOR, wait about 30 seconds.

STEP 3: Press the “SOURCE” button on the remote. Navigate to “HDMI 1.”

STEP 4: Press “MENU” on the remote to enter the settings menu.

STEP 5: Verify the settings below, navigating with the remote:

- SYSTEM
 - POWER CONTROL
 - AUTO POWER ON: ON
 - MAX POWER SAVING: OFF
 - STANDBY CONTROL: OFF
 - POWER BUTTON: POWER ON ONLY
 - AUTO SOURCE SWITCHING
 - AUTO SOURCE SWITCHING: OFF
 - SECURITY
 - BUTTON LOCK: ON

NERF™ Arcade

*****IMPORTANT*****

PLEASE FOLLOW INSTRUCTIONS TO SET UP MONITOR

SAMSUNG MONITOR SETTINGS

Model #QB65R

STEP 1: Verify game is connected to monitor in HDMI IN 1 at rear of monitor.

STEP 2: Power on GAME cabinet and MONITOR, wait about 30 seconds.

1. Language: English
2. Installation Type: Basic Setup
3. Display Orientation: Landscape
4. Wireless Connection: SKIP <right arrow>
5. PlayVia: Magicinfo
6. Connection to Magicinfo server: SKIP

STEP 3: Press the “SOURCE” button on the remote. Navigate to “HDMI 1.”

STEP 4: Press “MENU” on the remote to enter the settings menu.

STEP 5: Verify the settings below, navigating with the remote:

- SYSTEM
 - POWER CONTROL
 - AUTO POWER ON: ON
 - MAX POWER SAVING: OFF
 - STANDBY CONTROL: OFF
 - POWER BUTTON: POWER ON ONLY
 - AUTO SOURCE SWITCHING
 - AUTO SOURCE SWITCHING: OFF
 - SECURITY
 - BUTTON LOCK: ON

NERF™ Arcade

Card Reader Installation and Setup

Due to the rising popularity of aftermarket debit card systems for cashless or coinless operation of amusement machines (i.e. Embed, Intercard, Semnox), this NERF™ Arcade cabinet is equipped with UCL compatible harnessing to ensure that the installation process is easier and less prone to miswiring.

You can choose to use 1 or 2 card readers in the pricing adjustments section of the test menu. It is recommended to use 2 card readers for best results and player access.

There are (2) supplied connections, each located under the control panel near the player positions. There is enough slack to accommodate mounting (2) card readers on the control panel, or on the front panels, as each operator desires.

If only (1) card reader will be used, it is recommended that the card reader be mounted to the coin door using either the provided UCL connector.

UCL, or Universal Card Link, is a debit card standard established by the American Amusement Machine Association. Visit <https://coin-op.org/standardization/> for the latest UCL standard and manual information.

The UCL connections on the game use pins 1, 2, 6, 8, and 9. The other pins are unused. Each UCL connector can supply up to 1A at 12VDC.

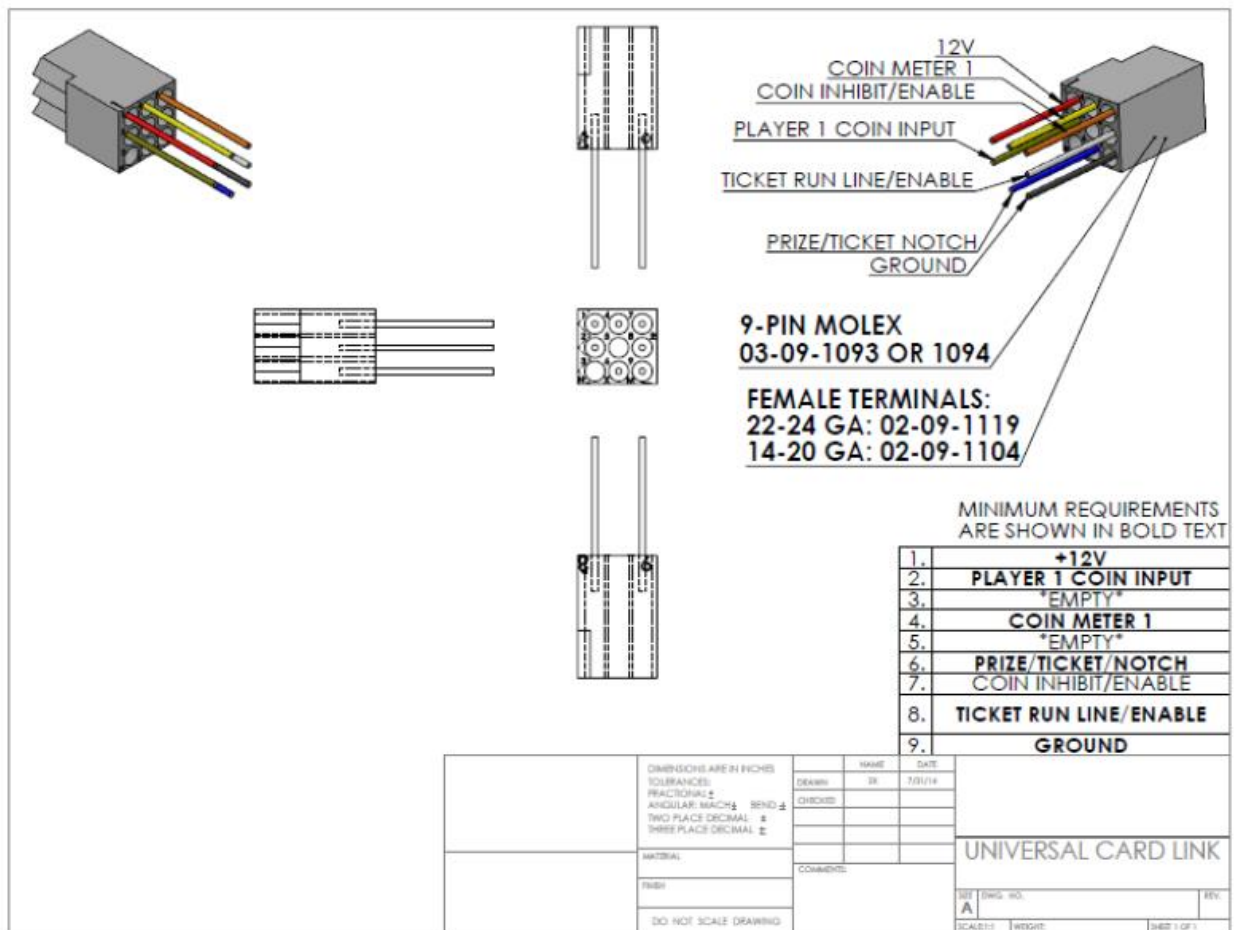

NERF™ Arcade

Check Electrical Settings

1. Verify the voltage in the nearest AC outlet.
2. Verify the AC outlet ground connection is present and working.

Startup Game

1. Plug in monitor and use remote to set up according to the instructions of page 21.
2. Plug in marquee power supply.
3. Plug the line cord into an AC outlet.
4. Turn the main cabinet power switch on.
5. Verify the game and all components are operating normally. See *Basic Functional Test on Initial Power Up* in the *Diagnostics and Adjustments* section for the recommended procedure.

NERF™ Arcade

Diagnostic and Adjustments

The Service Button Panel has four buttons, three of which can navigate the menu system.

The control panel buttons and guns can also advance through test menu screens.

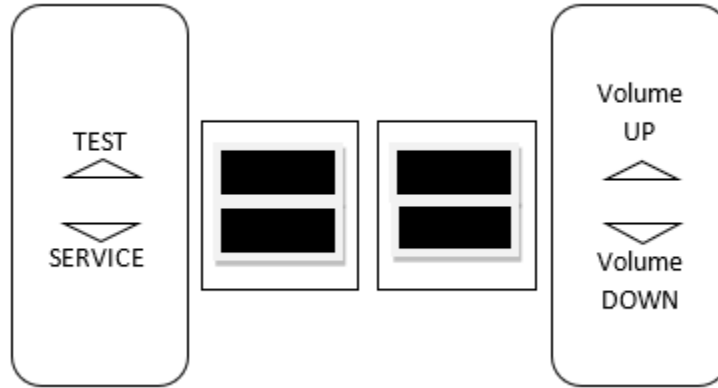

Navigating the Test Menu	
Button	Action
TEST (Not in Test Menu)	Enters Test Menu
TEST (In Test Menu)	Selects Highlighted Option
SERVICE (On Main Menu)	Exits Test Menu
SERVICE (Not on Main Menu)	Cancel Selection
VOLUME UP	Move Up
VOLUME DOWN	Move Down
Start Buttons	Selects Highlighted Option

An on-screen message acknowledges changes or when you exit a selection without making a change.

NERF™ Arcade

Basic Functional Test on Initial Power Up

1. Enter the Input Test and verify all switch inputs are working.
2. Enter the Monitor Test and verify the monitor is working properly.
3. Enter the Sound Test and verify the audio works and is not distorted.
4. Enter the Light Test and verify that all the lights are working properly.
5. Enter the Coin Meter Test and verify the coin meter is working properly.
6. Enter the Watchdog Test and verify the game reboots.
7. Upon a successful reboot, you are ready to adjust pricing, volume and other functions.

NERF™ Arcade

Test Menus

Main Menu

Choose from all available operator settings and menus here. You can use the test menu bracket and volume buttons to navigate. The guns also are available to use for easier navigation through these menus.

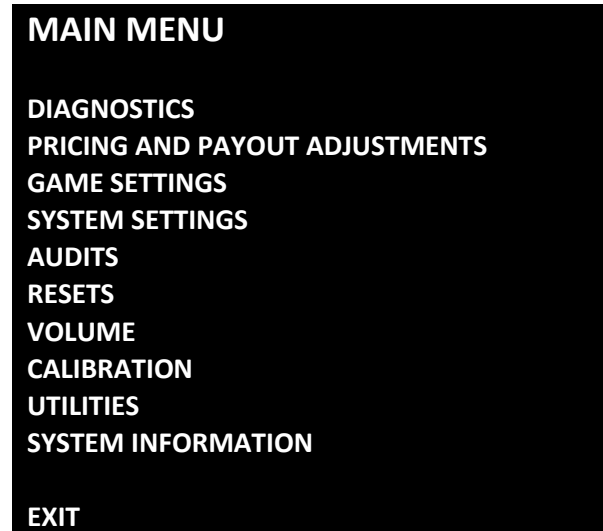

NERF™ Arcade

Diagnostics

Verify or diagnose the operations of all game functions.

DIAGNOSTICS

INPUT TEST

GUN SOLENOID TEST

GUN TRACKING TEST

VIDEO TEST

AUDIO TEST

CABINET LIGHTS TEST

METER TEST

TICKET TEST

WATCHDOG TEST

EXIT

- **Input Test:** Test input hardware such as switches.
- **Gun Solenoid Test:** Test the gun vibrations of the solenoids.
- **Gun Tracking Test:** Test the tracking of both guns.
- **Video Test:** Cycle through full screen colors on the monitor.
- **Audio Test:** Test audio using 100Hz and 1000Hz.
- **Cabinet Lights Test:** Tests all LED cabinet lighting together and individually.
- **Meter Test:** Test the functionality of the mechanical coin and ticket meters inside the cabinet.
- **Ticket Test:** Test the functionality of the ticket mech.
- **Watchdog Test:** Test the functionality of the watchdog reset.

NERF™ Arcade

Pricing and Payout Adjustments (Cash)

Set pricing and payout adjustments for game operation.

PRICING AND PAYOUT ADJUSTMENTS

(CASH)

CURRENCY INPUT

CURRENCY TYPE

COIN VALUE

COINS TO PLAY

PAYOUT PERCENT

TICKET VALUE

JACKPOT TICKETS

FIXED TICKET MODE

FREE PLAY

MERCY TICKETS

TWO POINT TICKETS

EXPRESS PAYOUT

EXIT

- **Currency Input**: Change the currency input.
- **Currency Type**: Change the currency type.
- **Coin Value**: Change the money value of the coin.
- **Coins to Play**: Adjust the amount of coins to start a game.
- **Payout Percent**: Set targeted payout percentage.
- **Ticket Value**: Set the value of your tickets.
- **Jackpot Tickets**: Set the value of the jackpot award.
- **Fixed Ticket Mode**: Award a fixed amount of tickets per play. No jackpot ticket options available when this mode is active.
- **Free Play**: Turn free play mode on or off.
- **Mercy Tickets**: Set the minimum number of tickets awarded on every play.
- **Two Point Tickets**: Allows a single ticket to be worth 2 points in the game.
- **Express Payouts**: Turn on or off. ON – tickets dispense as they are earned (recommended). OFF – ticket payout is dispensed at the end of the game.

NERF™ Arcade

Pricing and Payout Adjustments (Tokens)

Set pricing and payout adjustments for game operation.

PRICING AND PAYOUT ADJUSTMENTS

(TOKENS)

CURRENCY INPUT

CURRENCY TYPE

TOKEN VALUE

TOKENS TO PLAY

PAYOUT PERCENT

TICKET VALUE

JACKPOT TICKETS

FIXED TICKET MODE

FREE PLAY

MERCY TICKETS

TWO POINT TICKETS

EXPRESS PAYOUT

EXIT

- **Currency Input**: Change the currency input.
- **Currency Type**: Change the currency type.
- **Token Value**: Change the money value of the token.
- **Tokens to Play**: Adjust the number of tokens to start a game.
- **Payout Percent**: Set targeted payout percentage.
- **Ticket Value**: Set the value of your tickets.
- **Jackpot Tickets**: Set the value of the jackpot award.
- **Fixed Ticket Mode**: Award a fixed amount of tickets per play. No jackpot ticket options available when this mode is active.
- **Free Play**: Turn free play mode on or off.
- **Mercy Tickets**: Set the minimum number of tickets awarded on every play.
- **Two Point Tickets**: Allows a single ticket to be worth 2 points in the game.
- **Express Payouts**: Turn on or off. ON – tickets dispense as they are earned (recommended). OFF – ticket payout is dispensed at the end of the game.

NERF™ Arcade

Pricing and Payout Adjustments (Swipes)

Set pricing and payout adjustments for game operation.

PRICING AND PAYOUT ADJUSTMENTS

(SWIPES)

CURRENCY INPUT

CURRENCY TYPE

SWIPE VALUE (IMPORTANT SETTINGS)

NUMBER OF CARD READERS

PAYOUT PERCENT

TICKET VALUE

JACKPOT TICKETS

FIXED TICKET MODE

FREE PLAY

MERCY TICKETS

TWO POINT TICKETS

EXPRESS PAYOUT

EXIT

- **Currency Input**: Change the currency input.
- **Currency Type**: Change the currency type.
- **Swipe Value (IMPORTANT SETTING)**: Money value of the swipe. This important setting impacts payout.
- **Number of Card Readers**: Whether players share a cashbox, or each have their own. (DBV input is disabled when set to 2.)
- **Payout Percent**: Set targeted payout percentage.
- **Ticket Value**: Set the value of your tickets.
- **Jackpot Tickets**: Set the value of the jackpot award.
- **Fixed Ticket Mode**: Award a fixed amount of tickets per play. No jackpot ticket options available when this mode is active.
- **Free Play**: Turn free play mode on or off.
- **Mercy Tickets**: Set the minimum number of tickets awarded on every play.
- **Two Point Tickets**: Allows a single ticket to be worth 2 points in the game.
- **Express Payouts**: Turn on or off. ON – tickets dispense as they are earned (recommended). OFF – ticket payout is dispensed at the end of the game.

NERF™ Arcade

Game Settings

Adjust game settings for operation.

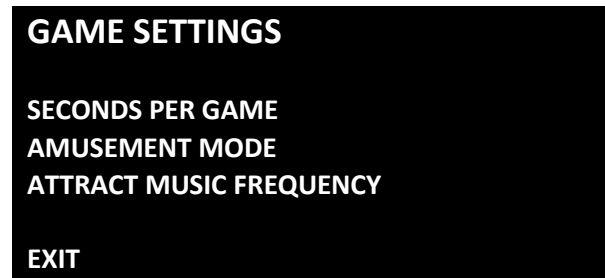

- **Seconds Per Game**: Set the number of seconds each game lasts.
- **Amusement Mode**: Points based mode with no ticket payouts and longer gameplay for non-redemption locations.
- **Attract Music Frequency**: Set how often music should be played in attract mode.

NERF™ Arcade

System Settings

Adjust system settings for operation.

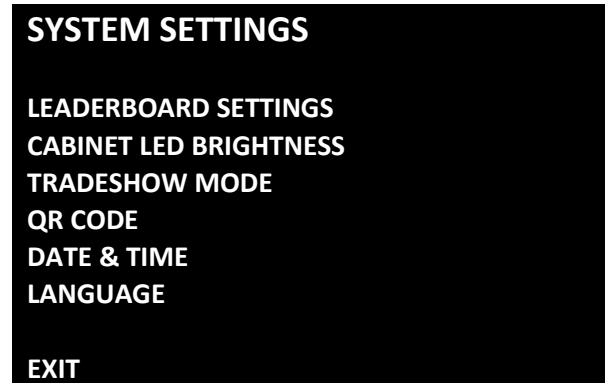

- **Leaderboard Settings**: Set whether name entry for high score table is turned on/off.
- **Cabinet LED Brightness**: Adjust the brightness of the cabinet lighting.
- **Tradeshow Mode**: Turn this mode on when operating on a trade show, sales floor, or demo floor.
- **QR Code**: Turn on/off the QR code feature, set venue name and location.
- **Date & Time**: Set the date and time.
- **Language**: Set language.

NERF™ Arcade

Audits

View machine statistics such as games played, money, earned, etc.

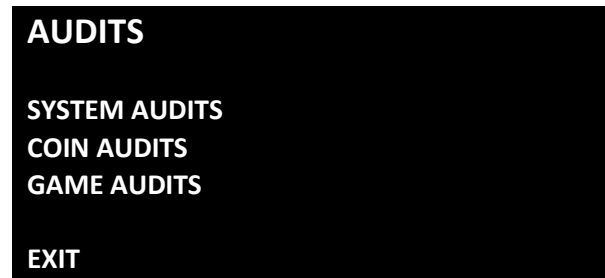

- **System Audits:** View system audits.
- **Coin Audits:** View coin audits.
- **Game Audits:** View game audits.

NERF™ Arcade

Resets

Reset various machine settings and audits.

RESETS

RESET CREDITS

RESET PLAYER 1 TICKETS

RESET PLAYER 2 TICKETS

RESET PRICING/PAYOUT ADJUSTMENTS

RESET GAME ADJUSTMENTS

RESET LEADERBOARDS

RESET GAME AUDITS

RESET SYSTEM AUDITS

RESET COIN AUDITS

RESET ALL AUDITS

FACTORY RESTORE

EXIT

- **Reset Credits:** Reset all credits to zero.
- **Reset Player 1 Tickets:** Clears out all tickets owed to player 1.
- **Reset Player 2 Tickets:** Clears out all tickets owed to player 2.
- **Reset Pricing/Payout Adjustments:** Reset all pricing and payout settings to default.
- **Reset Game Adjustments:** Reset all game settings to default.
- **Reset Leaderboards:** Reset all high score tables.
- **Reset Game Audits:** Reset all game related audits.
- **Reset System Audits:** Reset all system audits.
- **Reset Coin Audits:** Reset all coin audits.
- **Reset All Audits:** Reset all audits.
- **Factory Restore:** Restore game to all factory settings.

NERF™ Arcade

Volume

Adjust all volume settings.

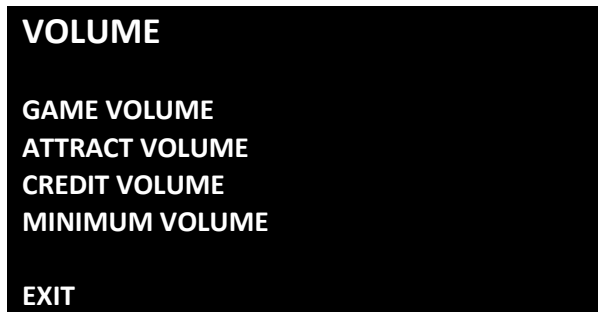

- **Game Volume**: Adjust the volume during gameplay.
- **Attract Volume**: Adjust the volume during the attract mode sequences.
- **Credit Volume**: Adjust the volume of the credit chime.
- **Minimum Volume**: Adjust the minimum volume.

NERF™ Arcade

Calibration

Calibrate the guns.



- **Gun Calibration:** Follow on screen prompts to calibrate guns.

NERF™ Arcade

Utilities

Miscellaneous operator tools.

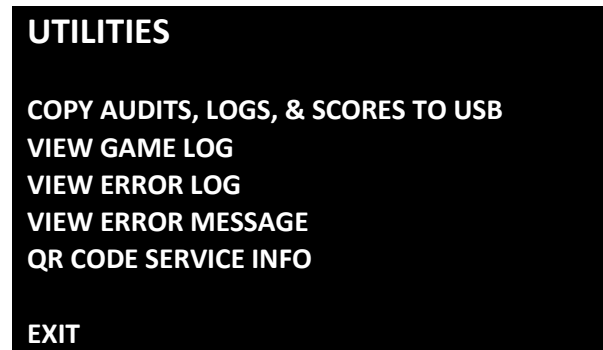

- **Copy Audits, Logs, & Scores to USB**: Copy all audits and diagnostics to USB drive.
- **View Game Log**: Examine logged messages from the game.
- **View Error Log**: Examine error messages from the game.
- **QR Code Service Info**: Send diagnostics info to Raw Thrills via cell phone QR scanner.

NERF™ Arcade

System Information

View hardware and software information.

- Serial Number
- Software Rev
- Build Date
- Dongle Version
- Cabinet Type
- Game Template

NERF™ Arcade

Choosing the Right Pricing Adjustments for Your Location

Card Swipe Locations

- Make Sure Your Game is Set to **Swipes Mode**:
 1. Hold the Test Button for 2 seconds to enter the Test Menu.
 2. Select “Pricing and Payout Adjustments” from the menu.
 3. Select “Currency Input” from the menu.
 4. Select “Card Swipes” from the menu.
 5. Exit out of “Currency Input” menu.
 6. While back in “Pricing and Payout Adjustments” menu, set “Swipe Value” to the currency equivalent of your swipe, or the payout will be incorrect. **THIS SETTING IS EXTREMELY IMPORTANT!** (Example: If the card swipe is worth \$1.50 in your card system, set the swipe value to \$1.50 as well).

Coin Locations

- Make Sure Your **Pricing & Coin Value** are Correct:
 1. Hold the Test Button for 2 seconds to enter the Test Menu.
 2. Select “Pricing and Payout Adjustments” from the menu.
 3. Select “Currency Input” from the menu.
 4. Select “Cash” or “Tokens” from the menu.
 5. Exit out of “Currency Input” menu.
 6. While back in “Pricing and Payout Adjustments” menu
 - a. Select “Coins/Tokens to Play” and set the desired amount of coins/tokens per game.
 - b. After setting the coins per play, set “Coin Value” to the currency equivalent of your coin, or the payout will be incorrect. **THIS SETTING IS EXTREMELY IMPORTANT!** (Example: If your coin is worth \$0.25, set “Coin Value” to \$0.25 as well).

NERF™ Arcade

PC Hardware

Your NERF™ Arcade uses a HP Elitedesk 705 G4 MT computer with a GeForce GTX 1050 graphics card. Listed below are the recommended BIOS settings for the computer.

NOTE 1

WARNING: DO NOT ENTER THE BIOS SETTINGS MENU! Modifying the BIOS settings will cause your game to stop functioning. In order to boot, new security features verify the BIOS settings against factory settings, including timestamp.

NOTE 2

In the event your video card needs to be replaced, any brand of GeForce GTX 1050 will work.



(HP Elitedesk 705 G4 MT)

NERF™ Arcade

PC Hard Drive Recovery

Symptoms requiring a PC hard drive recovery include:

- File test reports bad or missing files.
- Game fails to finish loading during setup.
- After resetting the AC power, an error is reported.
- Erratic Game or Attract Mode behavior.

The only way to repair corrupt files is to reinstall the software as described below:

Computer

The computer contains sensitive components. Do not handle roughly. Call your distributor before servicing its internal components. Ask about warranty information as it relates to the PC.

Do **not** use the PC on/off switch. Turn AC power on or off with the cabinet power switch.

Steps to Re-Install the software:

(NO DVD Restoration. USB Thumb Drive is used on the *HP Elitedesk 705 G4 MT*)

1. With game and PC on, verify that the RIO board has power. If not, see Troubleshooting.
2. Open the coin door.
3. Insert the recovery USB thumb drive (included in your game) into the USB port on the Test button bracket inside the coin door.
4. Open lower back door of cabinet and plug in USB keyboard to PC.
5. Turn cabinet power switch to OFF. Wait 30 seconds.
6. Turn cabinet power switch to ON, and **HOLD** F9 on the keyboard until the Boot Menu screen appears.
7. Use the Up and Down arrow keys to highlight “Legacy – JetFlash Mass Storage Device” and press enter.
8. Follow on screen instructions to begin recovery.
9. If recovery does not begin, check to ensure USB Drive is inserted correctly and is not damaged.
10. Initial software loading may take several minutes. Check progress periodically.
Do not interrupt power or reset the game during recovery.
11. When software has been loaded, a message indicates that restore is complete. When instructed to remove USB Drive, wait 15 seconds to remove the drive from the PC.
12. Turn cabinet power switch off and then turn the cabinet on again. Your game will now be restored.

NERF™ Arcade

Troubleshooting

Warning: Review the Safety section before making any adjustments to the game.

Problem	Possible Cause	Solution
Game will not power up.	Game not plugged in.	Plug game into AC outlet.
	Game not turned on.	Turn on main power switch.
	Game fuse is blown.	Check and replace fuse. See Specification section for fuse values.
	No power to receptacle.	Test AC outlet and plug game into powered outlet.
	Flash Drive Installer is left connected to PC.	Disconnect Flash Drive Installer and power cycle the game.
Buttons do not work.	Faulty micro switch.	Replace the micro switch on the button and re-test. Verify that the wires are connected to the correct spades on the micro switch.
	Faulty wiring.	Disconnect the cabinet from AC power. Verify that all wires are firmly connected to each button and the PCB. Verify that no wires are frayed or improperly shorting to ground. Verify that wires are connected to the correct spades on the micro switches.
	Faulty PCB.	Ensure all connections to PCB are secure. Replace PCB if faulty.

NERF™ Arcade

Problem	Possible Cause	Solution
Neither buttons nor audio work.	PCB connected to faulty USB port (boot message may indicate not detected)	To test a USB port, turn off the game, disconnect the device from the port, and then connect the game dongle to the port. Reboot the game. A No Dongle message indicates the port is bad. If the game starts, the port is working. After the test, reconnect all devices to the correct USB ports and reboot.
No sound or bad sound.	Bad connection.	Check connection to speakers.
	Volume set too low.	Use VOL UP button on Test panel to raise volume
	Faulty wiring.	Verify all wires are firmly connected to the speakers, PCB, and green computer audio port. Verify that each wire is connected to the correct port and no wires are frayed or improperly shorting to ground.
	Blown speakers.	Remove the grill and inspect each speaker for visible damage. Run the Sound Test from System Tests in the Operator Menu to verify each speaker is working.
	Reversed wires.	A weak or low muffled sound is a sign of reversed speaker wires. Check for reversed wires on each speaker.
Faulty PCB.	To verify audio is working at the computer, connect stereo headphones to the green computer audio port.	

NERF™ Arcade

Problem	Possible Cause	Solution
Constant low audio hum.	Faulty power supply.	Check external DC supply and the PC supply.
	Open ground.	Check all ground wires in cabinet. Ensure AC wall outlet is properly grounded
Game does not load.	PC hard drive failure.	Recover hard drive. See Flash Installer Document or contact your distributor for the latest software revision.
PC Drive test reports “bad” or “missing” files.		
Game fails to finish loading.		
After resetting, game still reports an error.		
Erratic game mode or attract mode.		
WARNING! Data files Corrupted. (Game Operation May Become Unstable.) Use “Test” Switch to Enter Test Mode and Run “File Test.”		
Game Resets	Bad file.	Run Flash Installer.
No Video	PC not turned on.	Turn PC power switch on. Ensure IEC cable tightly plugged in. Trace cable back to source to ensure continuity.
	Video cable not secure.	Check and secure DVI or HDMI connector to Monitor. Check and secure DVI or HDMI connector to PC.
Coin meter does not click during test.	No pulse to meter.	Check wiring from meter to PCB board.
	Faulty meter.	Replace coin meter.
	Blown fuse(s) on PCB	Replace 12vdc 5A fuse(s) on PCB.

NERF™ Arcade

Problem	Possible Cause	Solution
Dongle Not Present	Dongle missing or disconnected.	Find dongle cable and reseal in USB port.
	Faulty USB port.	Insert dongle cable in different USB port.
Improper number of credits given when coins or bills are inserted.	Incorrect setting in Pricing Adjustments.	Adjust pricing settings.
	Faulty wiring.	Disconnect cabinet from AC power. Verify wires are firmly connected to coin mech and bill validator and ground wires are properly connected. Verify no wires are frayed or shorting to ground.
	Faulty coin mech.	Verify coin mech is not jammed. Ensure coin mech is properly aligned and latched to coin door.
Exits Test Mode every 3 seconds.	Test button stuck in ON position.	Slide or toggle button off after Test Menu appears
Connect RIO Board or RIO Board Missing.	USB cable disconnected.	Check USB connection from PC to RIO board.
	No Power to RIO board.	Check for proper voltage (+5V, +12V) at RIO P1 connector.

NERF™ Arcade

Technical Support

For an authorized distributor near you, check the Raw Thrills website at www.rawthrills.com

Betson's Raw Thrills Technical Support Hotline

Phone: 1-800-753-2513

FAX: 1-201-438-5019

Email: rtsupport@betson.com



All Raw Thrills assembly and service videos:

rawthrills.com/assembly-and-service-videos/

NERF™ Arcade

Electrical and Mechanical Illustrations

ITEM NO.	PART NUMBER	DESCRIPTION	QTY.
1	Nerf_LCD_Stand_Assy	Full LCD Stand Assembly	1
2	Nerf_Player_Cabinet_Assy	Full Player Cabinet Assembly	1
3	Partec - 7-258	Black Rubber Cord Cover, Split, 3 ft Long	1

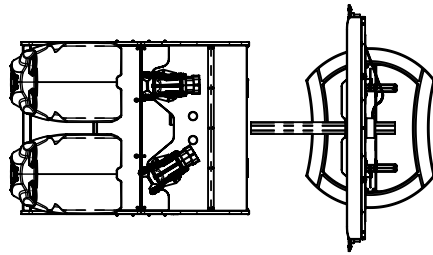
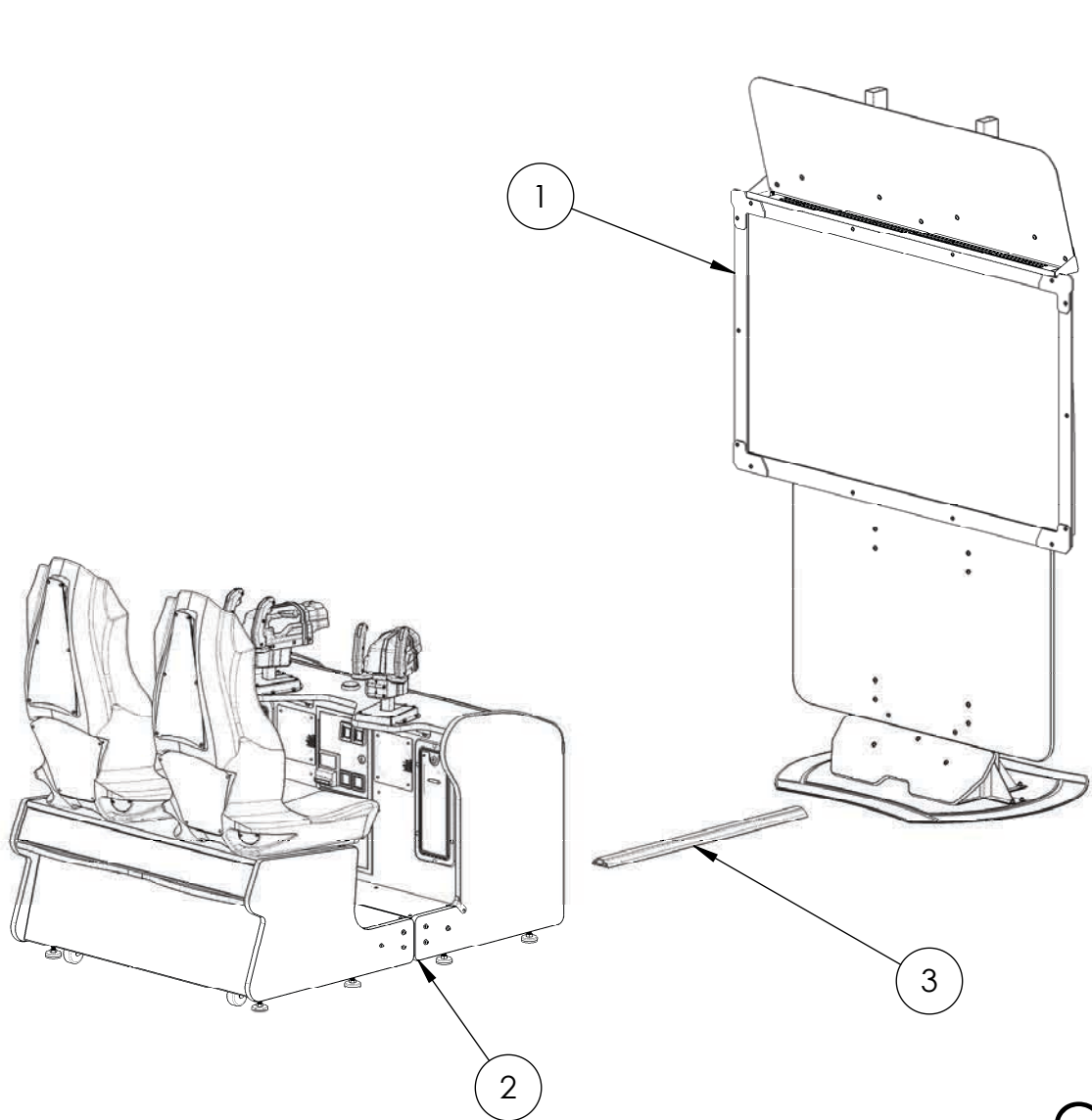

CABINET'S POWER LINE CORD AND HDMI CABLE SHOULD BE INSTALLED IN CORD COVER. CORD COVER MAY NEED TAPE TO SECURE TO FLOOR DEPENDING ON LOCATION.

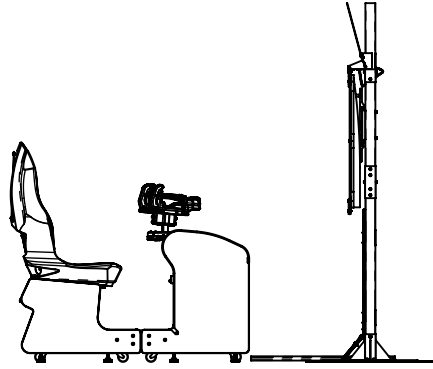

ASSEMBLED DIMENSIONS:
90.00" H x 61.75" W x 94.00-106.00" D

NERF Arcade Game Assembly (65")



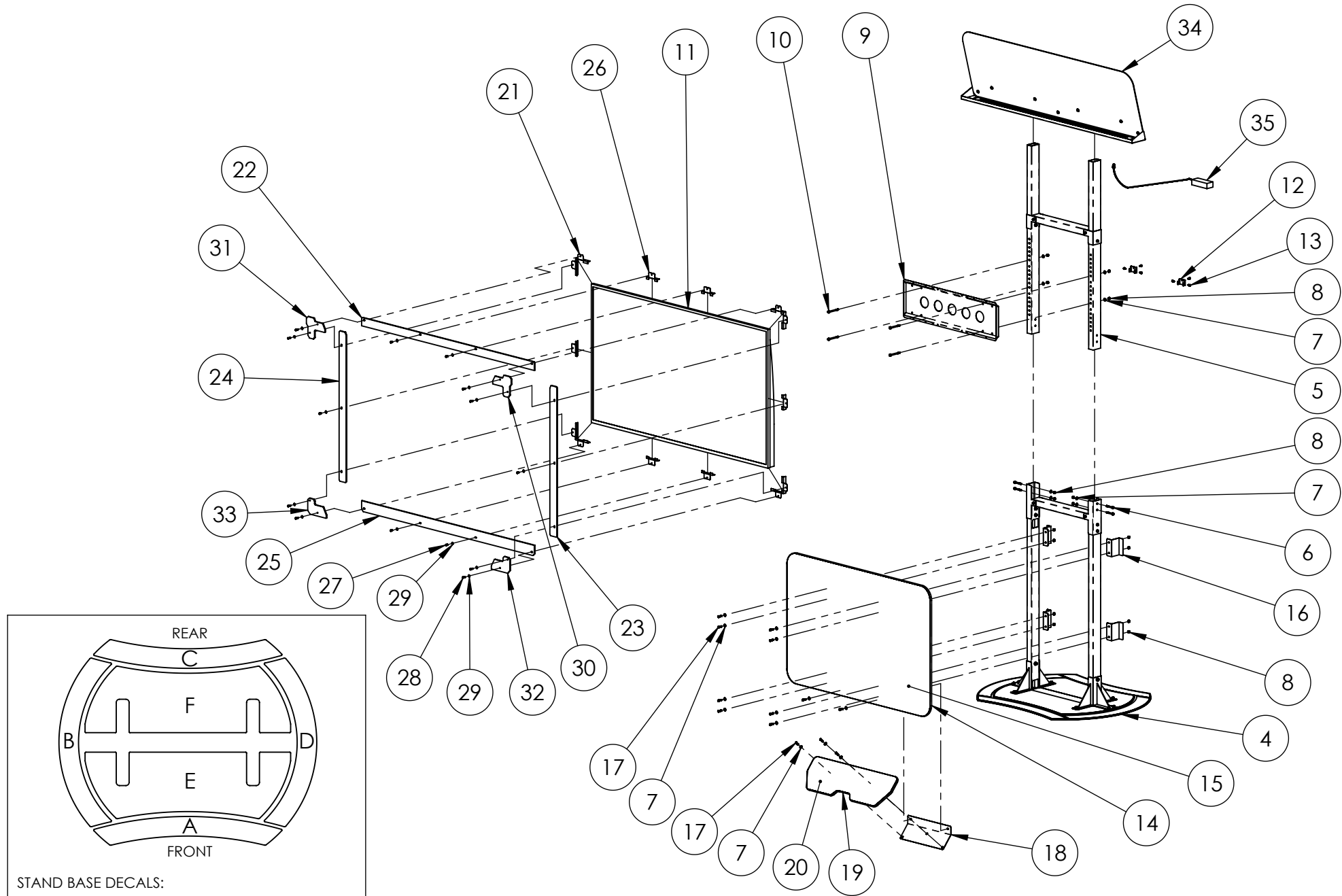

STAND BASE DECALS:

- A > 606-01714-01 - Front Outer Base Plate Decal
- B > 606-01715-01 - Left Outer Base Plate Decal
- C > 606-01716-01 - Rear Outer Base Plate Decal
- D > 606-01717-01 - Right Outer Base Plate Decal
- E > 606-01718-01 - Front Inner Base Plate Decal
- F > 606-01719-01 - Rear Inner Base Plate Decal

NERF Arcade
Full LCD Stand Assembly
(BOM on next page)



ITEM NO.	PART NUMBER	DESCRIPTION	QTY.
4	Lower_Half_Sub-Assy_of_Universal_LCD_Stand	Universal LCD Stand - Lower Half	1
5	Upper_Half_Sub-Assy_of_Universal_LCD_Stand	Universal LCD Stand - Upper Half	1
6	McMaster-Carr - 92316A550	High-Strength Grade 8 Steel Hex Head Screw, Flanged, 1/4"-20 Thread Size, 2" Long	4
7	McMaster-Carr - 97416A119	Black-Oxide Steel SAE Washer for 1/4" Screw Size, 0.281" ID, 0.625" OD	21
8	McMaster-Carr - 91333A150	Low-Strength Steel Nylon-Insert Locknut, Black Ultra-Corrosion-Resistant Coated, 1/4"-20 Thread Size	16
9	600-00752-01	Universal LCD Mount - Horizontal Bracket	1
10	McMaster-Carr - 92316A554	High-Strength Grade 8 Steel Hex Head Screw, Flanged, 1/4"-20 Thread Size, 3" Long	4
11	Nerf_Monitor_&_Mounting_Hooks	65" Monitor (QB65N/R) w/ Mounting Hook Brackets	1
12	600-00760-01	Universal LCD Mount - Securing Clip	2
13	McMaster-Carr - 90316A829	Stainless Steel Flanged Hex Head Screws with Slotted Drive, 10-32 Thread Size, 1/2" Long	6
14	601-00870-01	Lower Sign Panel	1
15	606-01703-01	Lower Sign Decal	1
16	600-02420-01	Marquee Cinch Bracket	4
17	McMaster-Carr - 96075A223	Alloy Steel Tamper-Resistant Button Head Torx Screws, 1/4"-20 Thread, 1" Long	13
18	600-02431-01	Lower Sign Bracket	1
19	601-00871-01	Angled Lower Panel	1
20	606-01704-01	Angled Lower Sign Decal	1
21	600-02429-01	Corner LED Bracket (w/ 3M VHB Tape, 1/2" Wide: 2x 3.75") - SEE NOTE	4
22	606-01705-01	Printed Monitor Bezel Upper Base Panel	1
23	606-01706-01	Printed Monitor Bezel Right Base Panel	1
24	606-01707-01	Printed Monitor Bezel Left Base Panel	1
25	606-01708-01	Printed Monitor Bezel Lower Base Panel	1
26	600-02428-01	Center LED Bracket (w/ 3M VHB Tape, 1/2" Wide: 1x 3.375") - SEE NOTE	6
27	McMaster-Carr - 96075A187	Alloy Steel Tamper-Resistant Button Head Torx Screws, 10-32 Thread, 1/2" Long	6
28	McMaster-Carr - 96075A191	Alloy Steel Tamper-Resistant Button Head Torx Screws, 10-32 Thread, 3/4" Long	8
29	McMaster-Carr - 97416A115	Black-Oxide Steel SAE Washer for Number 10 Screw Size, 0.219" ID, 0.5" OD	14
30	606-01709-01	Printed Monitor Bezel Upper Right Cap Panel	1
31	606-01710-01	Printed Monitor Bezel Upper Left Cap Panel	1
32	606-01711-01	Printed Monitor Bezel Lower Right Cap Panel	1
33	606-01712-01	Printed Monitor Bezel Lower Left Cap Panel	1
34	Nerf_Marquee_Assy	Marquee Assembly	1
35	Partec - CA-4588	Marquee Power Supply (& 8-582: Line Cord)	1

NOTE:
3M VHB Tape dependent on Monitor:
QB65R - use 4959 (.120" thick)
QB65N - use 4959 or 4952 (.045" thick)

NERF Arcade - Full LCD Stand Assembly: BOM



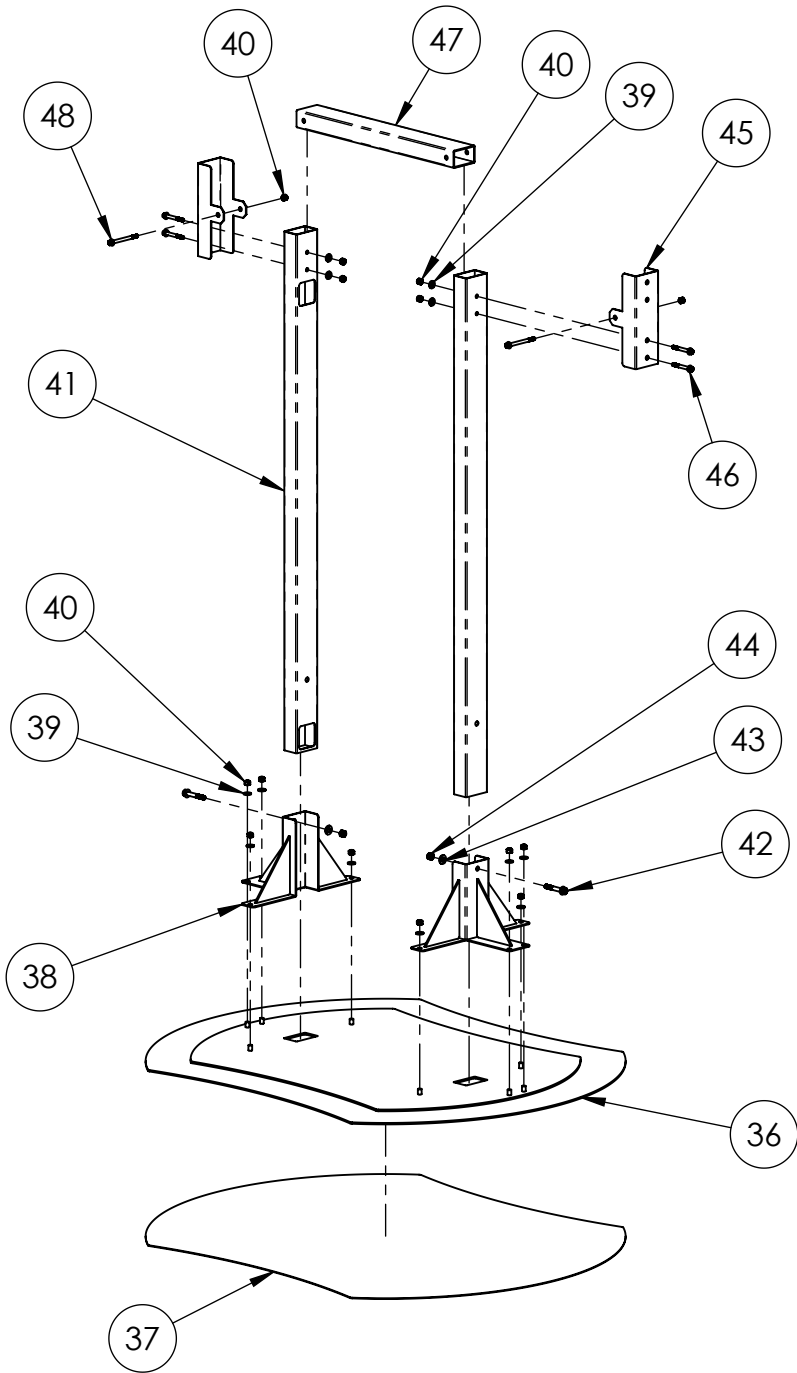

ITEM NO.	PART NUMBER	DESCRIPTION	QTY.
36	600-00990-01	Stand Base	1
37	600-00994-01	Rubber Base Pad	1
38	600-00989-01	Welded Tube Support	2
39	McMaster-Carr - 97416A119	Black-Oxide Steel SAE Washer for 1/4" Screw Size, 0.281" ID, 0.625" OD	12
40	McMaster-Carr - 91333A150	Low-Strength Steel Nylon-Insert Locknut, Black Ultra-Corrosion-Resistant Coated, 1/4"-20 Thread Size	14
41	600-00987-01	Lower Tube	2
42	McMaster-Carr - 92316A327	High-Strength Grade 8 Steel Hex Head Screw, Flanged, 5/16"-24 Thread Size, 2" Long	2
43	McMaster-Carr - 96765A145	Black-Oxide 18-8 Stainless Steel Washer for 5/16" Screw Size, 0.344" ID, 0.75" OD	2
44	McMaster-Carr - 94407A117	18-8 Stainless Steel Nylon-Insert Locknut, Black-Oxide, 5/16"-24 Thread Size	2
45	600-00985-01	Tube Joiner	2
46	McMaster-Carr - 92316A550	High-Strength Grade 8 Steel Hex Head Screw, Flanged, 1/4"-20 Thread Size, 2" Long	4
47	600-00991-01	Cross Tube	1
48	McMaster-Carr - 92316A554	High-Strength Grade 8 Steel Hex Head Screw, Flanged, 1/4"-20 Thread Size, 3" Long	2

NERF Arcade Universal LCD Stand - Lower Half



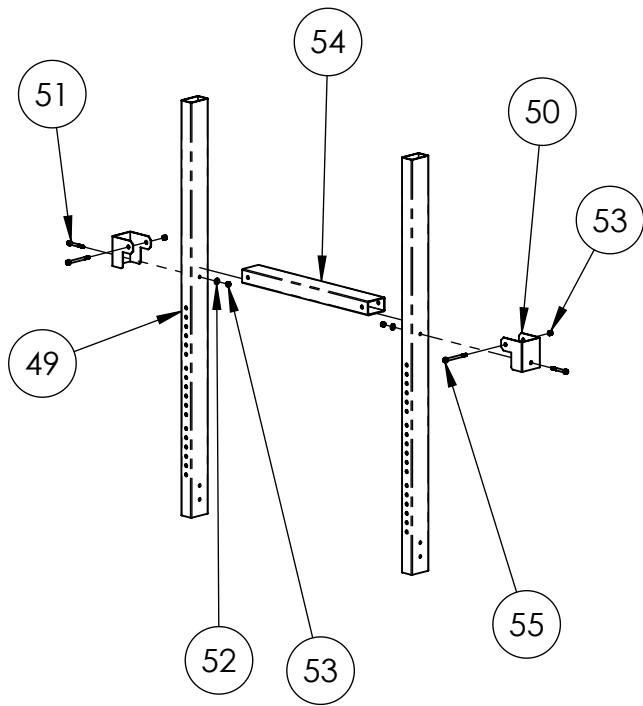

ITEM NO.	PART NUMBER	DESCRIPTION	QTY.
49	600-00986-01	Upper Tube	2
50	600-00988-01	Upper Bracket	2
51	McMaster-Carr - 92316A550	High-Strength Grade 8 Steel Hex Head Screw, Flanged, 1/4"-20 Thread Size, 2" Long	2
52	McMaster-Carr - 97416A119	Black-Oxide Steel SAE Washer for 1/4" Screw Size, 0.281" ID, 0.625" OD	2
53	McMaster-Carr - 91333A150	Low-Strength Steel Nylon-Insert Locknut, Black Ultra-Corrosion-Resistant Coated, 1/4"-20 Thread Size	4
54	600-00991-01	Cross Tube	1
55	McMaster-Carr - 92316A554	High-Strength Grade 8 Steel Hex Head Screw, Flanged, 1/4"-20 Thread Size, 3" Long	2

NERF Arcade Universal LCD Stand - Upper Half

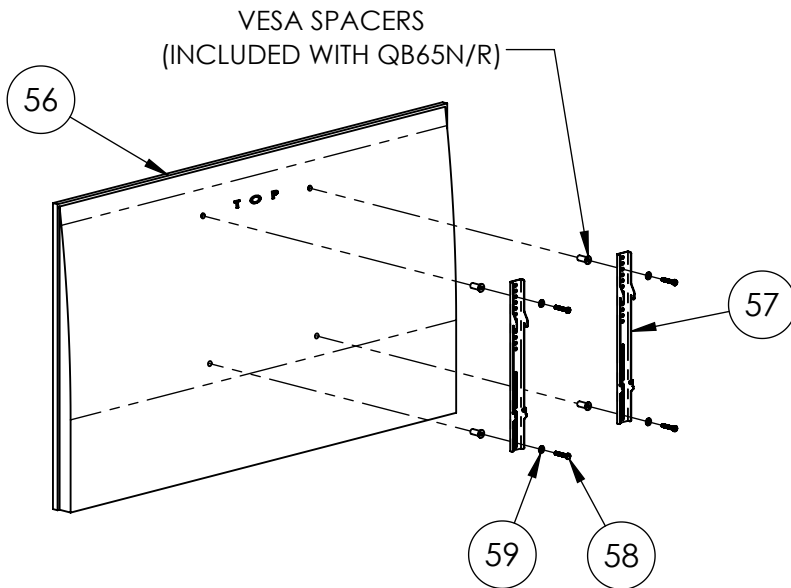

ITEM NO.	PART NUMBER	DESCRIPTION	QTY.
56	809-00016-01	65" Commercial Grade LED TV (Samsung QB65N/R w/ VESA Spacers)	1
57	600-00751-01	Universal LCD Mount - Vertical Bracket	2
58	McMaster-Carr - 91280A544	Medium-Strength Class 8.8 Steel Hex Head Screw, Zinc-Plated, M8 x 1.25 mm Thread, 45 mm Long	4
59	McMaster-Carr - 92141A030	18-8 Stainless Steel Washer for 5/16" Screw Size, 0.344" ID, 0.75" OD	4

NERF Arcade 65" Monitor w/ Mounting Hook Brackets



ITEM NO.	PART NUMBER	DESCRIPTION	QTY.
60	600-02426-01	Main Marquee Bracket	1
61	600-01735-01	Marquee LED Sintra Panel	1
62	Partec - CA-4176	Marquee LED Cable (500-00162-01: 3x 120cm)	1
63	McMaster-Carr - 91249A192	Black-Oxide 18-8 Stainless Steel Pan Head Phillips Screws, 8-32 Thread, 3/8" Long	8
64	McMaster-Carr - 97416A113	Black-Oxide Steel SAE Washer for Number 8 Screw Size, 0.188" ID, 0.438" OD	8
65	606-01671-01	Printed Marquee Panel	1
66	McMaster-Carr - 96075A211	Alloy Steel Tamper-Resistant Button Head Torx Screws, 1/4"-20 Thread, 1/2" Long	7
67	McMaster-Carr - 97416A119	Black-Oxide Steel SAE Washer for 1/4" Screw Size, 0.281" ID, 0.625" OD	7
68	600-02419-01	Marquee Mounting Bracket	1
69	600-02420-01	Marquee Cinch Bracket	2
70	McMaster-Carr - 91333A150	Low-Strength Steel Nylon-Insert Locknut, Black Ultra-Corrosion-Resistant Coated, 1/4"-20 Thread Size	8

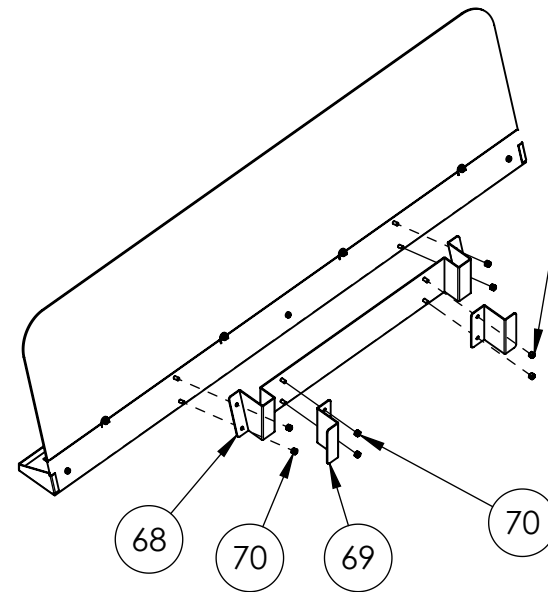
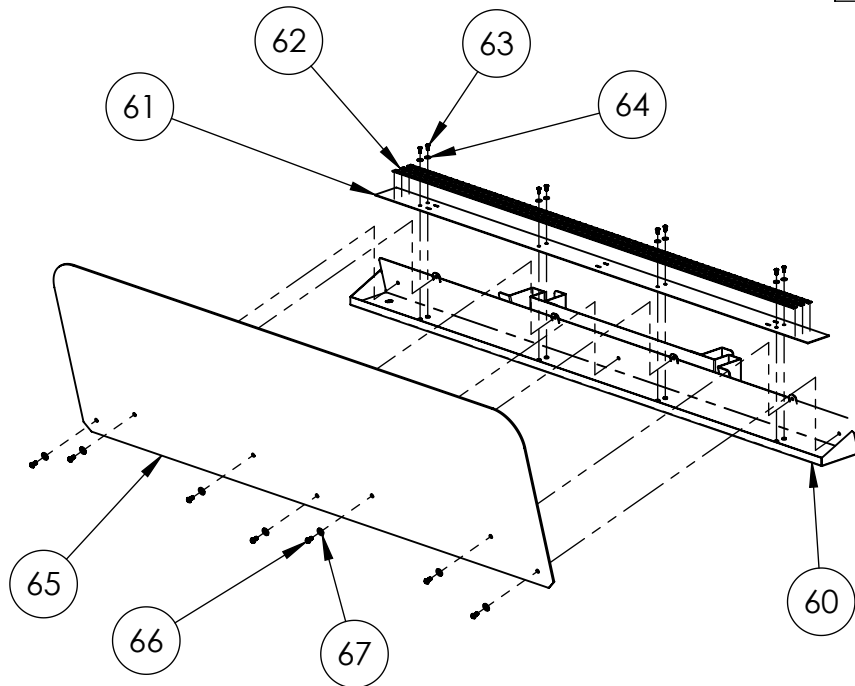

LOOSEN NUTS BEFORE INSTALLING MARQUEE ON UPPER TUBES OF LCD STAND ASSEMBLY. NUTS MUST BE FULLY TIGHTENED ONCE INSTALLED.

NERF Arcade Marquee Assembly



ITEM NO.	PART NUMBER	DESCRIPTION	QTY.
71	Nerf_Control_Assy	Control Cabinet Assembly	1
72	600-01457-01	Cabinet Connect Bracket	2
73	Partec - 31-TP250-03-004	Alloy Steel Tamper-Resistant Button Head Torx Screws, 1/4"-20 Thread, 2" Long	12
74	McMaster-Carr - 93711A500	Black-Oxide 18-8 Stainless Steel Split Lock Washer for 1/4" Socket Head Screws, 0.26" ID, 0.363" OD	14
75	McMaster-Carr - 97416A119	Black-Oxide Steel SAE Washer for 1/4" Screw Size, 0.281" ID, 0.625" OD	14
76	Nerf_Pedestal_Assy	Pedestal Cabinet Assembly	1
77	McMaster-Carr - 96075A231	Alloy Steel Tamper-Resistant Button Head Torx Screws, 1/4"-20 Thread, 1-1/2" Long	2
78	Nerf_Back_Door_Assy	Back Door Assembly	1
79	McMaster-Carr - 90190A201	Phillips Rounded Head Screws for Sheet Metal, Zinc-Plated Steel, Number 8 Size, 1-1/4" Long	6

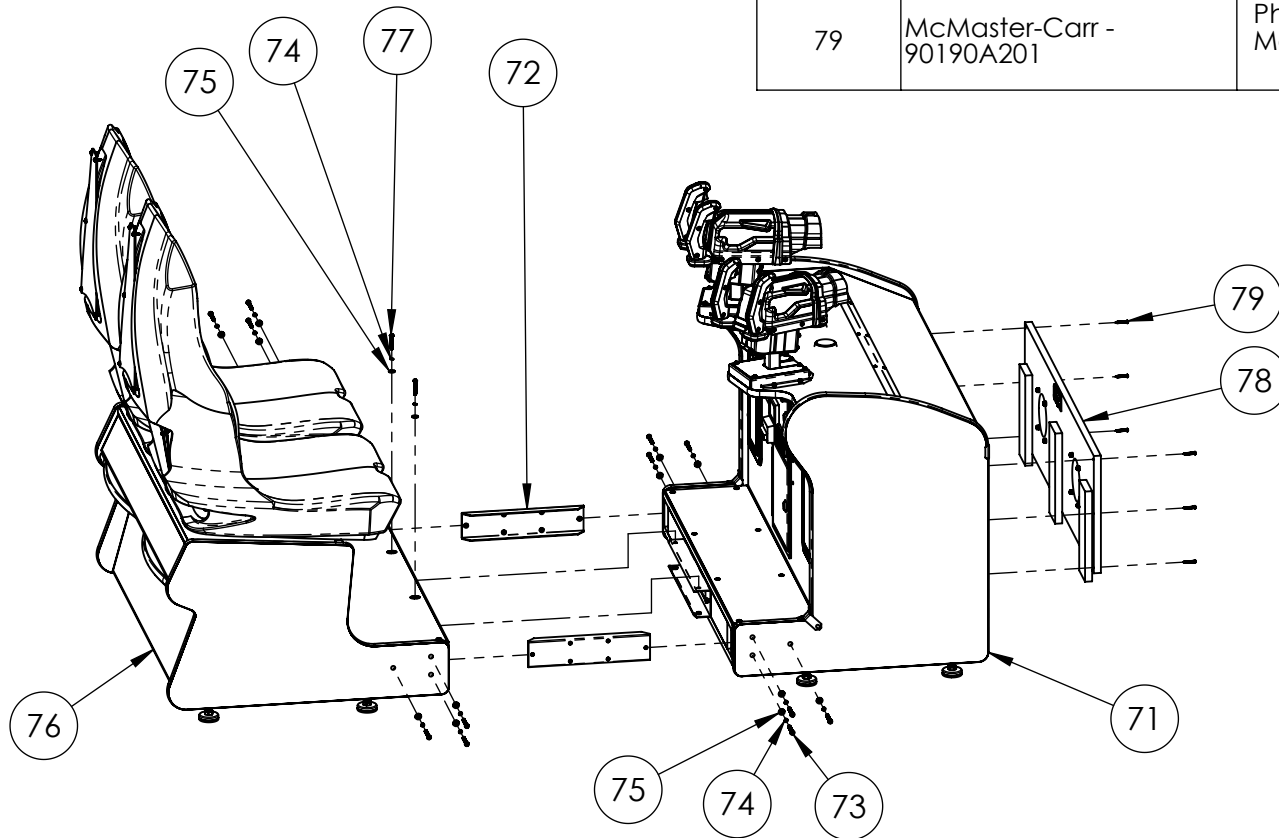

NERF Arcade Full Player Cabinet Assembly



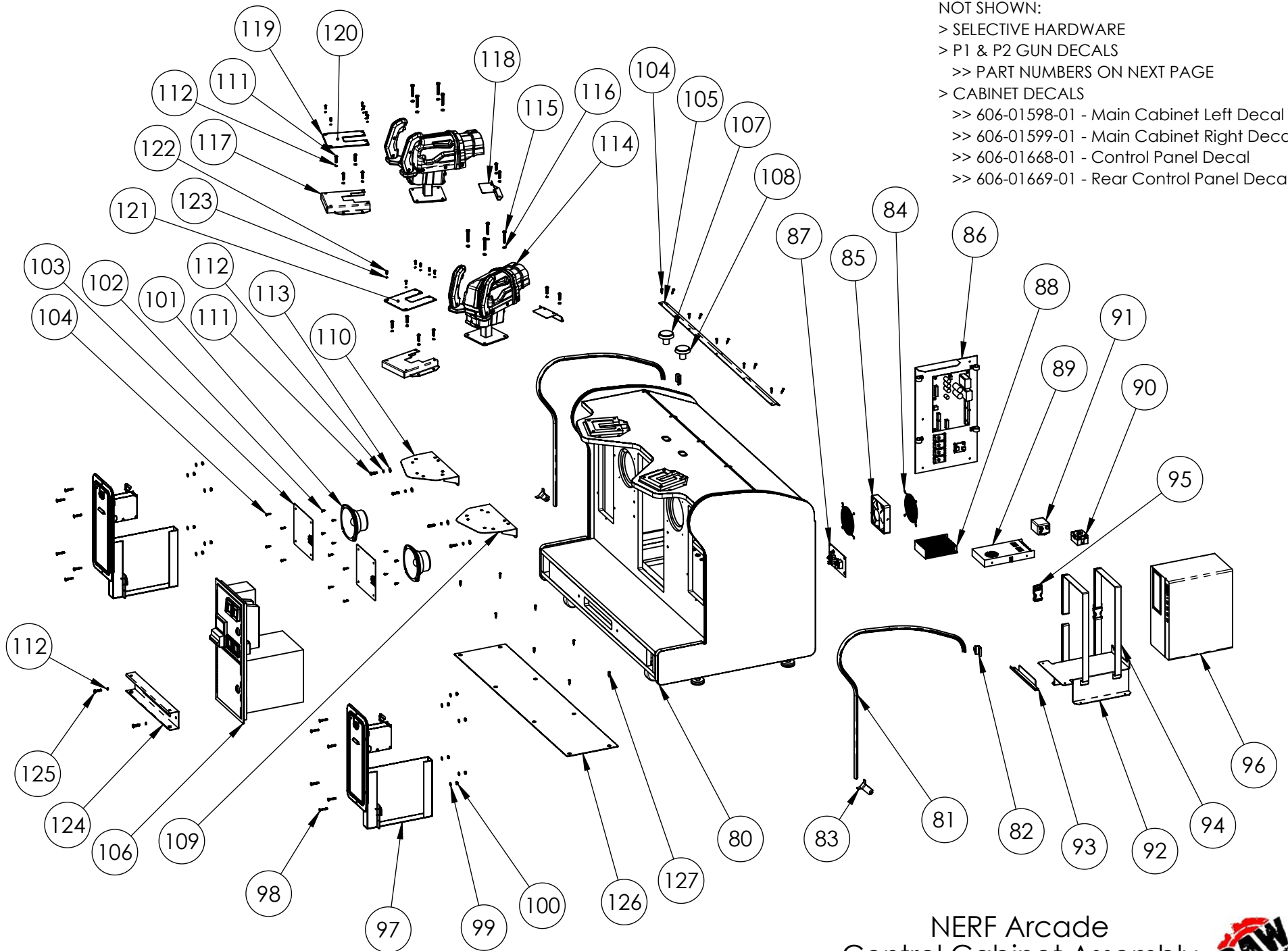

- NOT SHOWN:
- > SELECTIVE HARDWARE
 - >> PART NUMBERS ON NEXT PAGE
 - > CABINET DECALS
 - >> 606-01598-01 - Main Cabinet Left Decal
 - >> 606-01599-01 - Main Cabinet Right Decal
 - >> 606-01668-01 - Control Panel Decal
 - >> 606-01669-01 - Rear Control Panel Decal

NERF Arcade
Control Cabinet Assembly
(BOM on next page)



ITEM NO.	PART NUMBER	DESCRIPTION	QTY.
80	601-00867-01	Main Cabinet	1
81	603-00718-01 (47.5in)	LED T-Molding Extrusion - 47.5" (& CA-4231 - 500-00131-01: 1x 120CM)	2
82	600-01938-01	LED T-Molding Clip	2
83	600-01939-01	Flanged LED T-Molding Clip	2
84	800-00001-00	120mm Wire Fan Guard	2
85	Partec - CA-3277	Cooling Fan (standard size): 12VDC, 3W, 80CFM (820-00012-00)	1
86	Nerf_RIO_Assy	RIO Assembly w/ Mounting Plate	1
87	AC_Plate_Assy	AC Power Plate Sub-Assembly	1
88	330-00002-01	LRS-150F-24: 150W, 24V Low Leakage Power Supply	1
89	500-00193-01	RSP-320-12: 320W, 12V PFC Dual Voltage Power Supply	1
90	800-00040-01	6210AXXSZS-DC3 / 6210DSX-1: Solid State Relay	1
91	442-00001-01	Power Line Filter (Corcom 6MV1)	1
92	600-02422-01	PC Mounting Bracket	1
93	600-02427-01	PC Retaining Clip	1
94	McMaster-Carr - 87425K76 (56in)	Nylon Fabric Strip, Black, 1" Wide, .08" Thick, 56" Long	2
95	McMaster-Carr - 29705T86	Plastic Buckle, Black, Squeeze-Release, NO-Sew for 1" Webbing	2
96	850-00028-01	HP EliteDesk 705 G4 MT (& 310-00001-01: GTX1050 Video Card)	1
97	800-00043-01	Single Ticket Dispenser Door Assembly	2
98	Partec - 31-CB010-03-002	Black Oxide Steel Square-Neck Carriage Bolt, Low-Strength, 10-24 Thread Size, 1-1/4" Long	12
99	McMaster-Carr - 91090A103	Zinc-Plated Steel Oversized Washer for Number 10 Screw Size, 0.203" ID, 0.5" OD	12
100	McMaster-Carr - 90675A011	Steel Locknut with External-Tooth Lock Washer, Zinc-Plated, 10-24 Thread Size	12

PLAYER 1 GUN DECALS:

- > 606-01610-01 - P1 Gun Upper Left Decal
- > 606-01611-01 - P1 Gun Upper Right Decal
- > 606-01612-01 - P1 Gun Lower Left Decal
- > 606-01613-01 - P1 Gun Lower Right Decal
- > 606-01692-01 - P1 Gun Small Lower Left Decal
- > 606-01693-01 - P1 Gun Small Lower Right Decal
- > 606-01694-01 - P1 Gun Grip Plate Decal
- > 606-01698-01 - Gun Front Decal

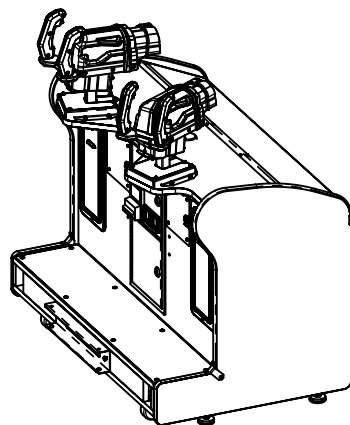

PLAYER 2 GUN DECALS:

- > 606-01620-01 - P2 Gun Upper Left Decal
- > 606-01621-01 - P2 Gun Upper Right Decal
- > 606-01622-01 - P2 Gun Lower Left Decal
- > 606-01623-01 - P2 Gun Lower Right Decal
- > 606-01695-01 - P2 Gun Small Lower Left Decal
- > 606-01696-01 - P2 Gun Small Lower Right Decal
- > 606-01697-01 - P2 Gun Grip Plate Decal
- > 606-01698-01 - Gun Front Decal

ITEM NO.	PART NUMBER	DESCRIPTION	QTY.
101	2-1-10-00-00-000	5.25" Speaker, 8 Ohm, Full Range (Goldwood)	2
102	McMaster-Carr - 90935A194	Phillips Rounded Head Screws for Sheet Metal, Black-Oxide Steel, Number 8 Size, 1/2" Long	8
103	600-01464-01	Speaker Grill	2
104	Partec - 31-TP008-03-003	Tamper-Resistant Torx Rounded Head Screws for Sheet Metal, Black Oxide Steel, Number 8 Size, 3/4" Long	18
105	600-01944-01	Cabinet Seam Plate	1
106	Partec - AS-2565	Mid-Width Coin Door (800-00005-01) Assembly w/ Test Switches and Ticket Meter	1
107	702-00019-01	Large Round Blue IPB (.187 Gold MS, 6V White LED)	1
108	702-00007-01	Large Round Green IPB (.187 Gold MS, 6V White LED)	1
109	600-01912-01	Gun Gusset Bracket R	1
110	600-01913-01	Gun Gusset Bracket L	1
111	McMaster-Carr - 96075A223	Alloy Steel Tamper-Resistant Button Head Torx Screws, 1/4"-20 Thread, 1" Long	16
112	McMaster-Carr - 93711A500	Black-Oxide 18-8 Stainless Steel Split Lock Washer for 1/4" Socket Head Screws, 0.26" ID, 0.363" OD	18
113	McMaster-Carr - 97416A119	Black-Oxide Steel SAE Washer for 1/4" Screw Size, 0.281" ID, 0.625" OD	4
114	Nerf_Gun_Mech_Assy (Partec - AS-3473)	NERF Arcade Gun Mech	2
115	McMaster-Carr - 92865A548	Medium-Strength Grade 5 Steel Hex Head Screw, Zinc-Plated, 1/4"-20 Thread Size, 1-3/4" Long, Fully Threaded	8
116	McMaster-Carr - 91102A750	Zinc-Plated Steel Split Lock Washer for 1/4" Screw Size, 0.26" ID, 0.487" OD	8
117	600-01936-01	Gun Plate Rear	2
118	600-01937-01	Gun Plate Front	2
119	600-01486-01	Dash Gun Cover Plate	2
120	606-01608-01	P1 Gun Plate Decal	1
121	606-01609-01	P2 Gun Plate Decal	1
122	McMaster-Carr - 96075A139	Alloy Steel Tamper-Resistant Button Head Torx Screws, 8-32 Thread, 1/2" Long	12
123	McMaster-Carr - 93711A300	Black-Oxide 18-8 Stainless Steel Split Lock Washer for Number 8 Socket Head Screws, 0.174" ID, 0.267" OD	12
124	600-01458-01	Center Connect Bracket	1
125	McMaster-Carr - 92865A542	Medium-Strength Grade 5 Steel Hex Head Screw, Zinc-Plated, 1/4"-20 Thread Size, 1" Long	2
126	600-01992-01	Main Cabinet Tread Plate	1
127	McMaster-Carr - 95638A197	Tamper-Resistant Torx Rounded Head Screws for Sheet Metal, 18-8 Stainless Steel, Number 8 Size, 3/4" Long	8

NERF Arcade
Control Cabinet Assembly
BOM



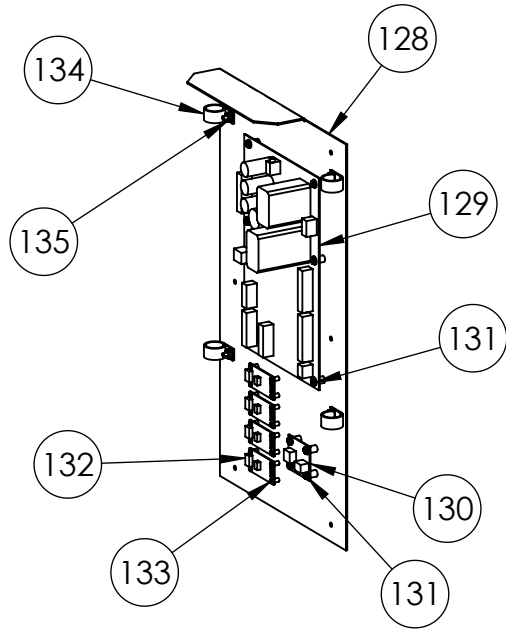

ITEM NO.	PART NUMBER	DESCRIPTION	QTY.
128	600-01914-01	RIO Mounting Plate	1
129	500-00040-02	RIO PCB	1
130	500-00194-01	5V, 5A Switching Regulator PCB (12V input)	1
131	McMaster-Carr - 90316A192	Stainless Steel Flanged Hex Head Screws with Slotted Drive, 8-32 Thread Size, 3/8" Long	10
132	520-00024-01	Aliens / Terminator Deluxe Gun Kickboard	4
133	McMaster-Carr - 90272A106	Steel Pan Head Phillips Screws, 4-40 Thread, 1/4" Long	16
134	AEH - 04-12-750	Wire Harness Clip (for 3/4" Bundle Diameter)	4
135	McMaster-Carr - 90675A009	Steel Locknut with External-Tooth Lock Washer, Zinc-Plated, 8-32 Thread Size, 11/32" Wide	4

NERF Arcade RIO Assembly w/ Mounting Plate

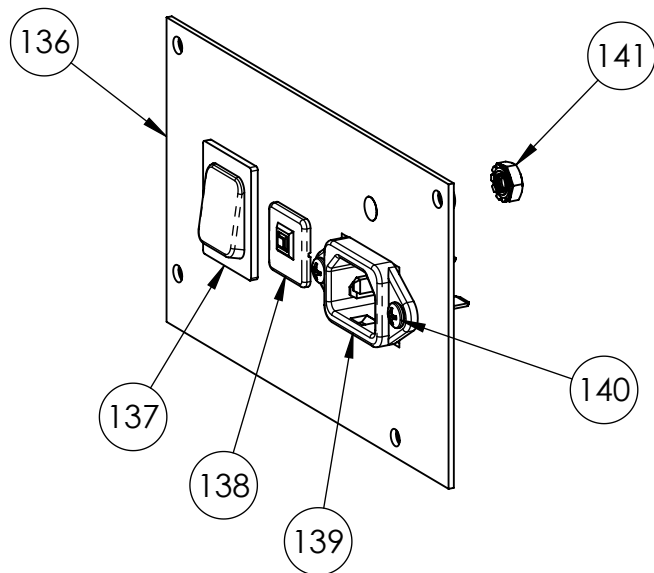

ITEM NO.	PART NUMBER	DESCRIPTION	QTY.
136	600-01681-01	AC Electronics Plate	1
137	Marquardt - 1832.3312	Rocker Switch (DPST): 250VAC, 16A	1
138	Schurter - T9-611P-A	Thermal Circuit Breaker: 240VAC, 6A, Snap-in, Fuseholder, 1 Pole	1
139	Qualtek - 703W-00/08	AC Receptacle: 250V, 15A	1
140	McMaster-Carr - 90272A146	Steel Pan Head Phillips Screws, 6-32 Thread, 3/8" Long	2
141	McMaster-Carr - 90675A195	Steel Locknut with External-Tooth Lock Washer, Zinc-Plated, 10-32 Thread Size	1

NERF Arcade AC Power Plate Sub-Assembly



NOT SHOWN:

> CABINET DECALS

- >> 606-01600-01 - Seat Cabinet Upper Rear Decal
- >> 606-01601-01 - Seat Cabinet Left Decal
- >> 606-01602-01 - Seat Cabinet Right Decal
- >> 606-01603-01 - Seat Cabinet Lower Rear Decal

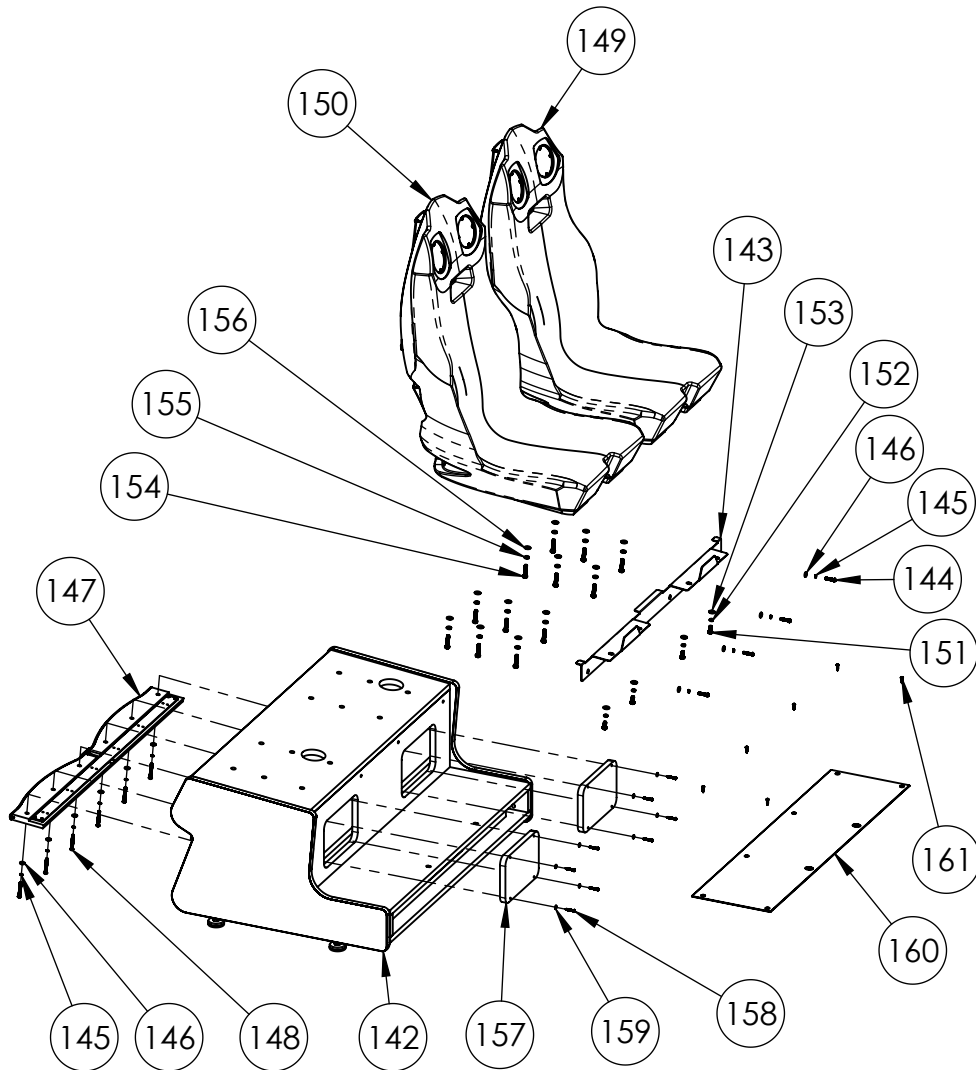

ITEM NO.	PART NUMBER	DESCRIPTION	QTY.
142	601-00868-01	Seat Cabinet	1
143	600-01915-01	Seat Mount Bracket	1
144	Partec - 31-TP250-03-001	Black Oxide Steel Tamper-Resistant Button Head Torx Screws, 1/4"-20 Thread Size, 1-1/4" Long	4
145	McMaster-Carr - 93711A500	Black-Oxide 18-8 Stainless Steel Split Lock Washer for 1/4" Socket Head Screws, 0.26" ID, 0.363" OD	10
146	McMaster-Carr - 97416A119	Black-Oxide Steel SAE Washer for 1/4" Screw Size, 0.281" ID, 0.625" OD	10
147	Nerf_Rear_Seat_LED_Cap_Assy	Rear Seat LED Cap Assembly	1
148	Partec - 31-TP250-03-004	Alloy Steel Tamper-Resistant Button Head Torx Screws, 1/4"-20 Thread, 2" Long	6
149	Nerf_Seat_Assy_P1	Player 1 Seat Assembly (BLUE)	1
150	Nerf_Seat_Assy_P2	Player 2 Seat Assembly (GREEN)	1
151	McMaster-Carr - 92965A581	Black-Oxide Grade 5 Steel Hex Head Screws, Medium-Strength, 5/16"-18 Thread Size, 3/4" Long	4
152	McMaster-Carr - 93711A600	Black-Oxide 18-8 Stainless Steel Split Lock Washer for 5/16" Socket Head Screws, 0.322" ID, 0.457" OD	4
153	McMaster-Carr - 96765A145	Black-Oxide 18-8 Stainless Steel Washer for 5/16" Screw Size, 0.344" ID, 0.75" OD	4
154	McMaster-Carr - 92865A587	Medium-Strength Grade 5 Steel Hex Head Screw, Zinc-Plated, 5/16"-18 Thread Size, 1-1/2" Long, Fully Threaded	12
155	McMaster-Carr - 91102A755	Zinc-Plated Steel Split Lock Washer for 5/16" Screw Size, 0.322" ID, 0.583" OD	12
156	McMaster-Carr - 92141A030	18-8 Stainless Steel Washer for 5/16" Screw Size, 0.344" ID, 0.75" OD	12
157	601-00783-01	Seat Access Panel	2
158	Partec - 31-TP008-03-002	Tamper-Resistant Torx Rounded Head Screws for Sheet Metal, Black Oxide Steel, Number 8 Size, 1-1/4" Long	8
159	McMaster-Carr - 97416A113	Black-Oxide Steel SAE Washer for Number 8 Screw Size, 0.188" ID, 0.438" OD	8
160	600-01993-01	Seat Cabinet Tread Plate	1
161	McMaster-Carr - 95638A197	Tamper-Resistant Torx Rounded Head Screws for Sheet Metal, 18-8 Stainless Steel, Number 8 Size, 3/4" Long	6

NERF Arcade Pedestal Cabinet Assembly



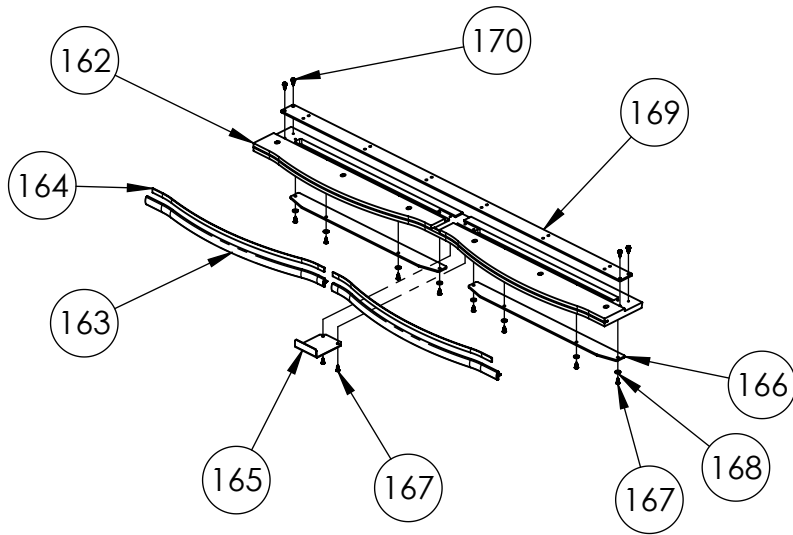

ITEM NO.	PART NUMBER	DESCRIPTION	QTY.
162	601-00782-01	LED Cap Panel	1
163	603-00718-01 (20.5in)	LED T-Molding Extrusion - 20.5"	2
164	Partec - CA-4514	LED Cap T-Molding Cable (500-00131-01: 2x 50cm)	1
165	600-01744-01	LED Cap Bracket	1
166	603-00805-01	LED Cap Lens	2
167	Partec - 31-TP008-03-010	Tamper-Resistant Torx Rounded Head Screws for Sheet Metal, Black Oxide Steel, Number 8 Size, 1/2" Long	10
168	McMaster-Carr - 97416A113	Black-Oxide Steel SAE Washer for Number 8 Screw Size, 0.188" ID, 0.438" OD	8
169	Nerf_Rear_Seat_LED_Assy	Rear Seat LED Assembly	1
170	McMaster-Carr - 90054A194	Flanged Hex Head Screws for Sheet Metal, Zinc-Plated Steel, Number 8 Size, 1/2" Long	4

NERF Arcade Rear Seat LED Cap Assembly

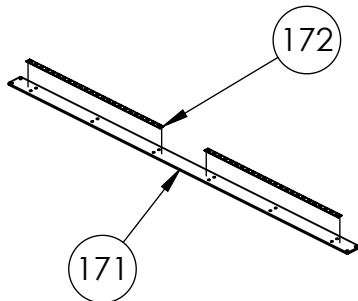

ITEM NO.	PART NUMBER	DESCRIPTION	QTY.
171	603-00806-01	LED Cap Back	1
172	Partec - CA-4515	LED Cap Down Lighting Cable (500-00162-01: 2x 40cm)	1

NERF Arcade Rear Seat LED Assembly



ITEM NO.	PART NUMBER	DESCRIPTION	QTY.
173	603-00523-01	Red Plastic Seat	1
174	600-00105-01	Seat Headrest Grill	2
175	600-00620-01	Middle Seat Plate	1
176	Partec - 31-TP008-03-003	Tamper-Resistant Torx Rounded Head Screws for Sheet Metal, Black Oxide Steel, Number 8 Size, 3/4" Long	24
177	500-00065-01	Red LED Puck Light w/ Black PCB	2
178	603-00540-01	LED Spotlight Lens - Red Tint	2
179	603-00762-01 (2in)	LED Strip Holder Extrusion - 2"	2
180	603-00762-01 (3in)	LED Strip Holder Extrusion - 3"	1
181	McMaster-Carr - 90054A196	Flanged Hex Head Screws for Sheet Metal, Zinc-Plated Steel, Number 8 Size, 5/8" Long	15
182	Partec - CA-4455	Seatback LED Cable (500-00093-01: 2x 35cm)	1
183	807-00003-00	6.5" Woofer, 4 Ohm (Goldwood)	1
184	603-00762-01 (28in)	LED Strip Holder Extrusion - 28"	1
185	Partec - CA-4510	Seatback Woofer LED Cable (500-00219-01: 1x 70cm)	1
186	600-00106-01	Woofer Grill	1
187	McMaster-Carr - 90133A013	Oil-Resistant Neoprene Rubber Sealing Washer for Number 10 Screw Size, 0.17" ID, 0.375" OD	6
P1 Seat Marquee - BLUE			
188	606-01607-01	P1 Seat Marquee PETG	1
P2 Seat Marquee - GREEN			
189	606-01624-01	P2 Seat Marquee PETG	1

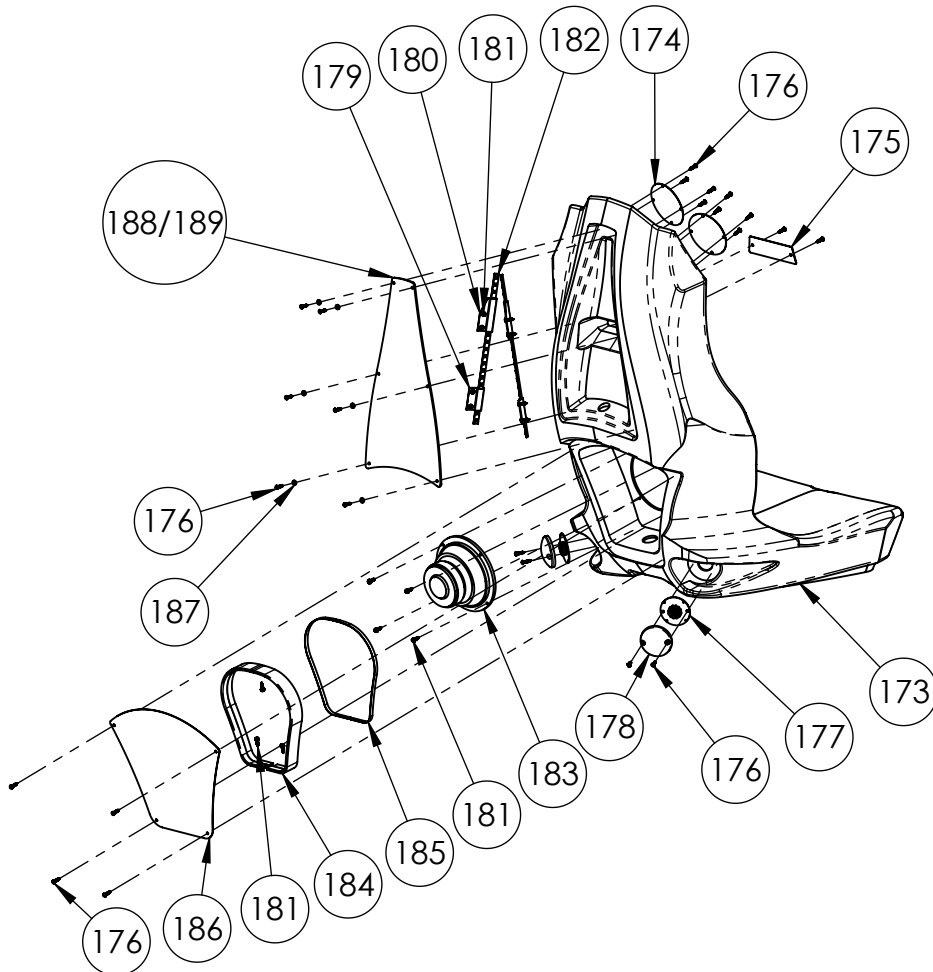

NERF Arcade Seat Assembly

(unique seat marquee for P1 & P2)



ITEM NO.	PART NUMBER	DESCRIPTION	QTY.
190	601-00780-01	Back Door	1
191	800-00001-00	120mm Wire Fan Guard	2
192	Partec - 31-MS008-01-009	Zinc Plated Steel Pan Head Phillips Screw, 8-32 Thread, 1-1/8" Long	8
193	McMaster-Carr - 90126A512	Zinc-Plated Steel SAE Washer for Number 8 Screw Size, 0.188" ID, 0.438" OD	8
194	McMaster-Carr - 90631A009	Low-Strength Steel Nylon-Insert Locknut, Zinc-Plated, 8-32 Thread Size	8
195	600-00043-01	Lock Retainer Plate	1
196	McMaster-Carr - 90054A196	Flanged Hex Head Screws for Sheet Metal, Zinc-Plated Steel, Number 8 Size, 5/8" Long	3
197	150-00001-00	Standard Door Lock Assembly (for 3/4" Panels)	1

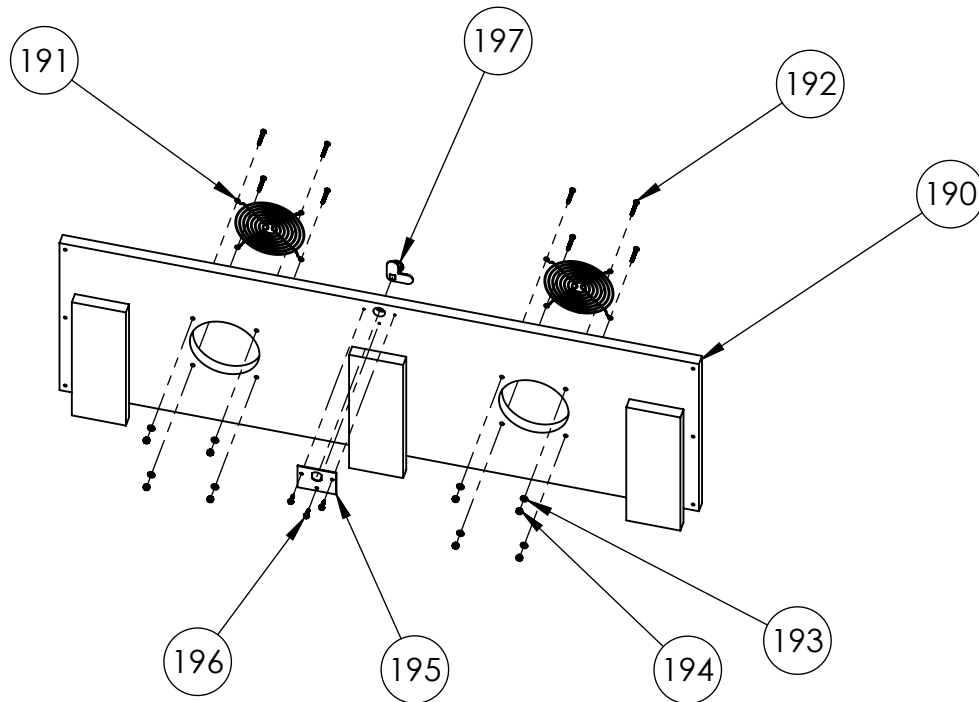

NERF Arcade Back Door Assembly



REV.	DESCRIPTION	DATE
A	RELEASED	10/18/14
B	REVISED	1/9/15
C	NO CHANGE THIS SHEET	12/14/16
D	ADDED UPPER VACFORM PART NUMBER AND CORRECTED FRONT VACFORM BRACKET IMAGE	5/10/19

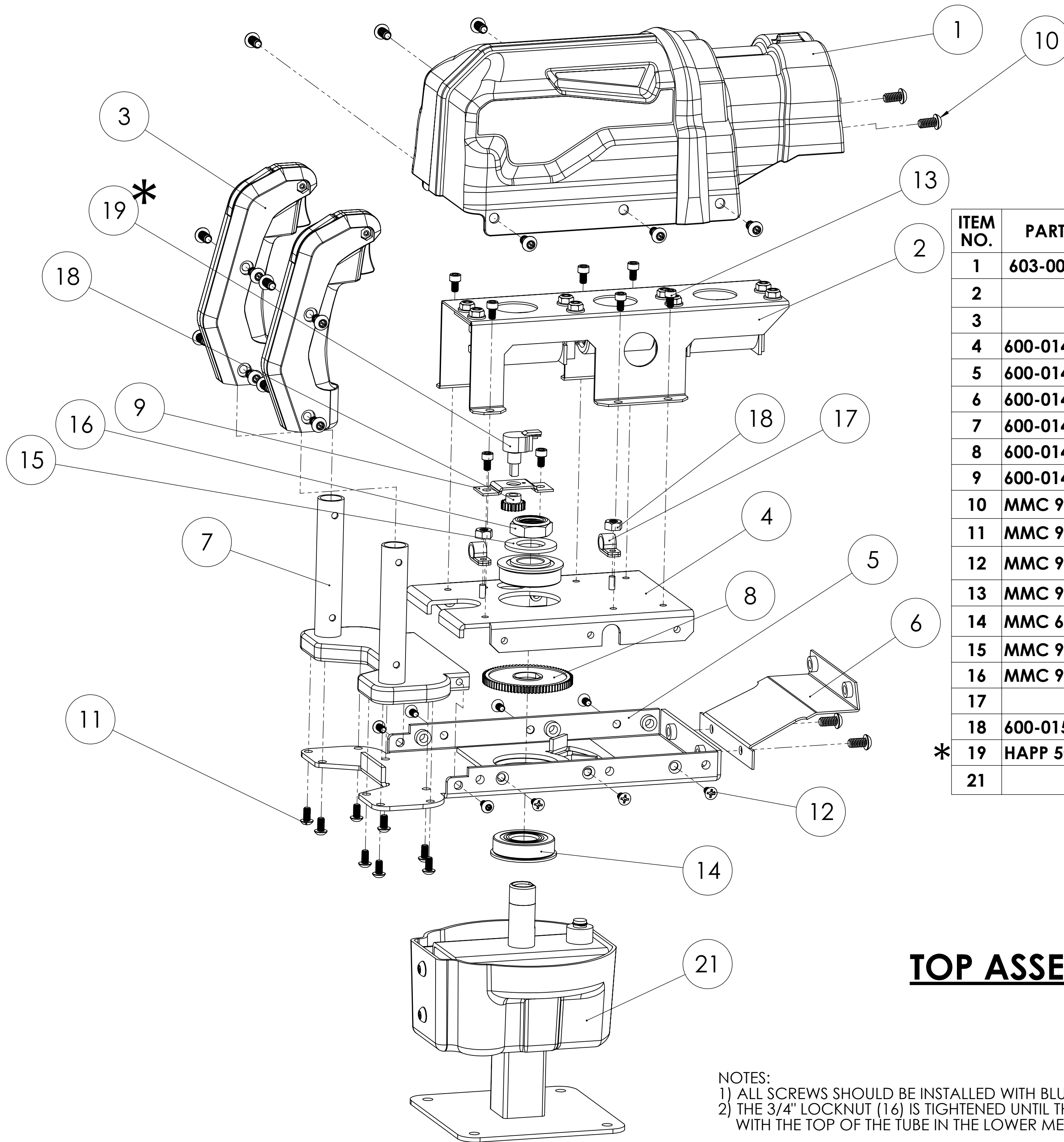

ITEM NO.	PART NUMBER	DESCRIPTION	QTY.
1	603-00755-01	UPPER VACFORM	1
2		SHAKER ASSEMBLY	1
3		GRIP ASSEMBLY	2
4	600-01422-01	PIN PLATE	1
5	600-01423-01	COVER BRACKET	1
6	600-01495-01	FRONT VACFORM BRACKET	1
7	600-01411-01	GRIP PLATE WELDMENT	1
8	600-01420-01	LARGE GEAR	1
9	600-01491-01	POT BRACKET	1
10	MMC 96075A211	1/4-20 X 1/2" BLK TP SCREW	18
11	MMC 96075A183	10-32 X 3/8" BLK TP SCREW	10
12	MMC 90273A827	10-32 X 3/8" FLAT HEAD SCREW	6
13	MMC 91251A337	10-32 X 5/16" CAP SCREW	8
14	MMC 6384K369	3/4" FLANGED BEARING	2
15	MMC 90126A036	3/4" WASHER	1
16	MMC 91342A240	3/4" LOCKNUT	1
17		CABLE CLAMP	2
18	600-01567-01	SMALL POT GEAR	1
* 19	HAPP 50-2670-01	POT - 5K	1
21		LOWER MECH ASSEMBLY	1

* Scan QR Code for Video Instruction:
Replacing Side-to-Side Potentiometer
youtu.be/8AGiy0Ljlw8



TOP ASSEMBLY

NOTES:
1) ALL SCREWS SHOULD BE INSTALLED WITH BLUE LOCTITE 242 or 243.
2) THE 3/4" LOCKNUT (16) IS TIGHTENED UNTIL THE TOP IS FLUSH WITH THE TOP OF THE TUBE IN THE LOWER MECH ASSEMBLY (21).

RAW THRILLS INC.	
TITLE: GUN MAIN ASSEMBLY	
TOL: .X ±.030 .XX ±.015 .XXX ±.005	MATERIAL:
Holes: +.002/-0.00	FINISH: SEE NOTES
ANGLES: ±0.5°	PART NO.
SHEET 1 of 3	REV D

REV.	DESCRIPTION	DATE
A	RELEASED	10/18/14
B	REVISED	1/9/15
C	CHANGED TO MOLDED LOWER COVER	12/14/16
D	CORRECTED NOTE #2	5/10/19

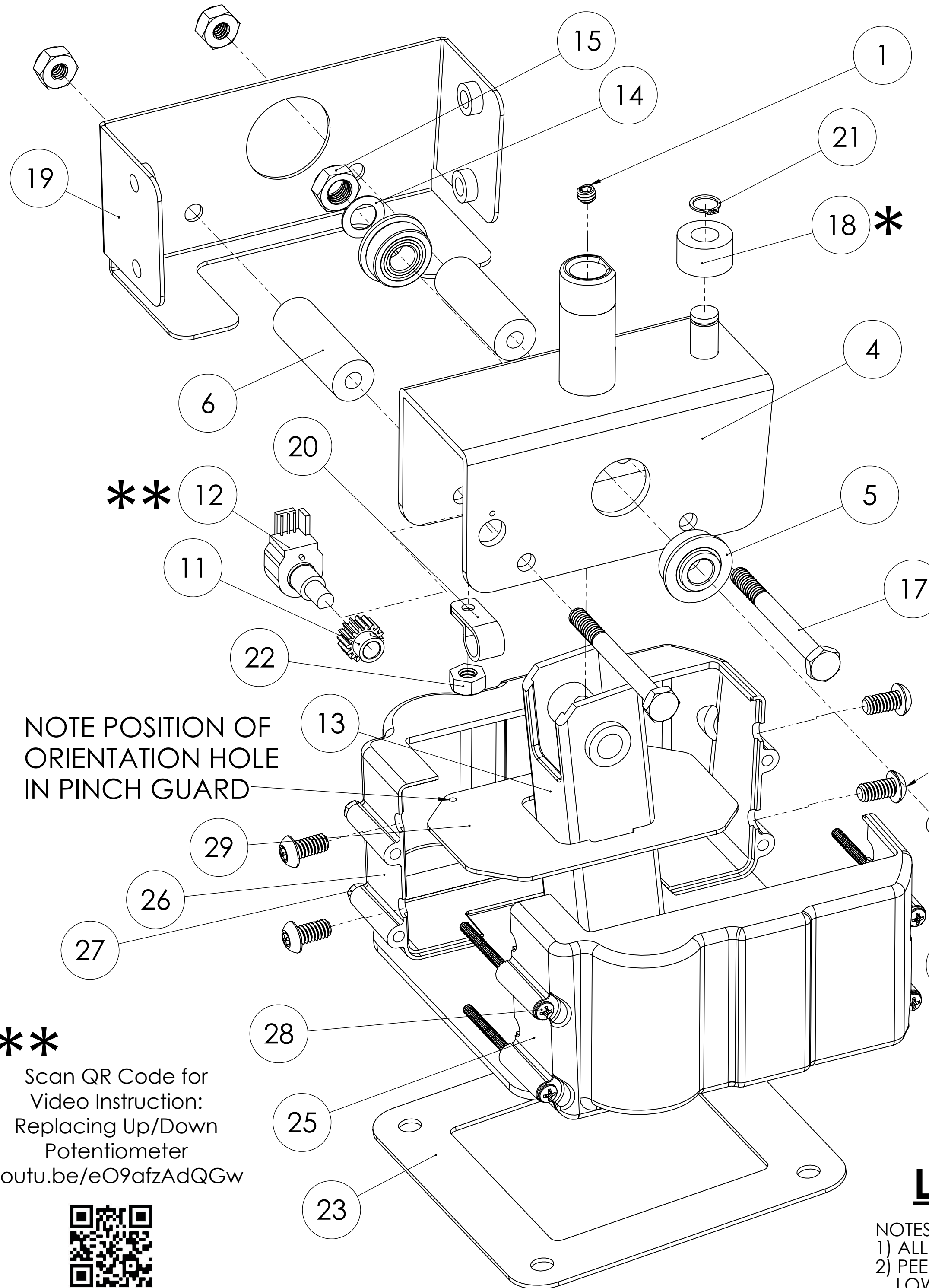

ITEM NO.	PART NUMBER	DESCRIPTION	QTY.	
1	MMC 92313A532	1/4-20 x 3/16" SET SCREW	1	
2	MMC 96075A211	1/4-20 X 1/2" BLK TP SCREW	4	
3	603-00756-01	LOWER VACFORM	1	
4	600-01425-01	ROCKER BRACKET	1	
5	MMC 6384K344	3/8" FLANGED BEARING	2	
6	600-01418-01	TUBE STOP BUMPER - 5/8" OD	2	
7	600-01424-01	SIDE PIN	1	
8	MMC 90652A029	1/4-20 THIN LOCKNUT	3	
9	MMC 90108A413	1/4-20 WASHER	1	
10	HAPP 96-4907-00	SEGMENT GEAR	1	
11	600-01567-01	POT GEAR	1	
**	12	HAPP 50-2670-01	POT - 5K	1
13	600-01426-01	LOWER TUBE WELDMENT	1	
14	MMC 95229A480	3/8" WASHER	1	
15	MMC 90566A220	3/8" THIN LOCKNUT	1	
17	MMC 91257A552	1/4-20 x 2 1/2 HEX HEAD - GRADE 8	2	
*	18	600-01417-01	SHORT STOP BUMPER - 3/4" OD	1
19	600-01496-01	LOWER VACFORM MOUNTING BRACKET	1	
20		CABLE CLAMP	1	
21	MMC 947633A170	RETAINING CLIP	1	
22	MMC 90675A009	8/32" KEPS NUT	1	
23	600-01577-01	GUN ISOLATOR	1	
25	600-01739-01	BOTTOM COVER - RIGHT	1	
26	600-01738-01	BOTTOM COVER - LEFT	1	
27	999-00021-01	6-32 HEX LOCKNUT - BLACK	4	
28	999-00017-01	6-32 X 2.5" PHILLIPS HEAD SCREW - BLACK	4	
29	600-01419-01	PINCH COVER	1	

NOTE POSITION OF ORIENTATION HOLE IN PINCH GUARD

* Scan QR Code for Video Instruction: Replacing Side-to-Side Stop
youtu.be/S3Op7Z8Hwuk



** Scan QR Code for Video Instruction: Replacing Up/Down Potentiometer
youtu.be/eO9afzAdQGw



LOWER MECH ASSEMBLY

NOTES:
 1) ALL SCREWS SHOULD BE INSTALLED WITH BLUE LOCTITE 242 or 243.
 2) PEEL AND STICK GUN ISOLATOR (#23) TO BOTTOM OF LOWER TUBE WELDMENT (#13)

RAW THRILLS INC.	
TITLE: GUN MAIN ASSEMBLY	
TOL: .X ±.030 .XX ±.015 .XXX ±.005	MATERIAL:
HOLES: +.002/-0.000	FINISH: SEE NOTES
ANGLES: ±0.5°	PART NO.
SHEET 2 of 3	REV D

REV.	DESCRIPTION	DATE
A	RELEASED	10/18/14
B	REVISED	1/9/15
C	NO CHANGE THIS SHEET	12/14/16
D	NO CHANGE THIS SHEET	5/10/19

ITEM NO.	PART NUMBER	DESCRIPTION	QTY.
1	600-01576-01	COIL MOUNT BRACKET	4
2	600-01412-01	COIL BRACKET	1
3	608-00216-01	COIL FL11629	2
4	600-01413-01	COIL ROD	1
5	600-01414-01	COIL WEIGHT	1
6	MMC 91375A535	1/4-20 x 3/8" SET SCREW	1
7	680-00214-01	BLUE DAMPER PAD	2
8	608-00210-01	COIL SPRING	2
9	HAPP #95-0637-00	COIL SLEEVE	2
10	MMC 93298A109	10-32 FLANGED LOCKNUT	8

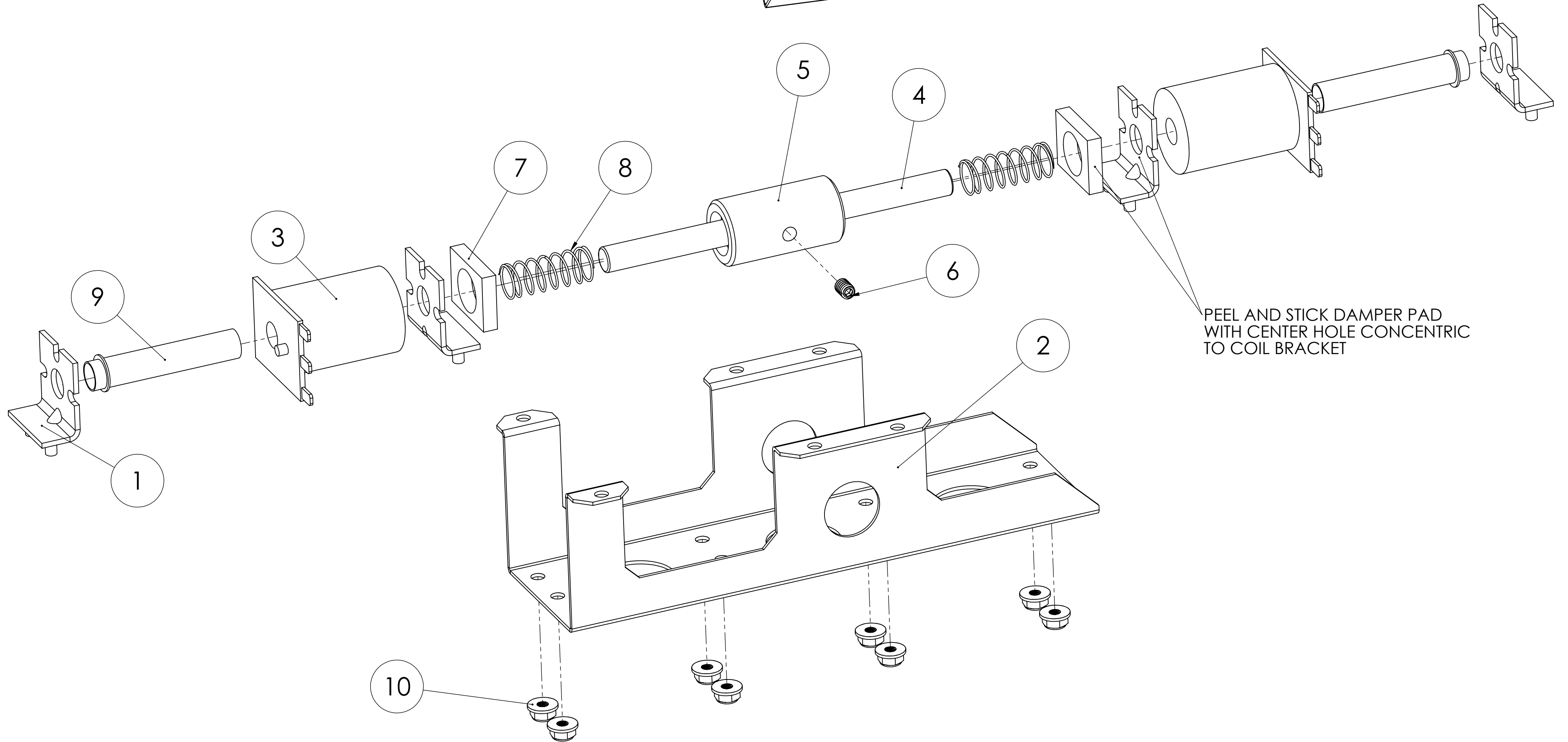
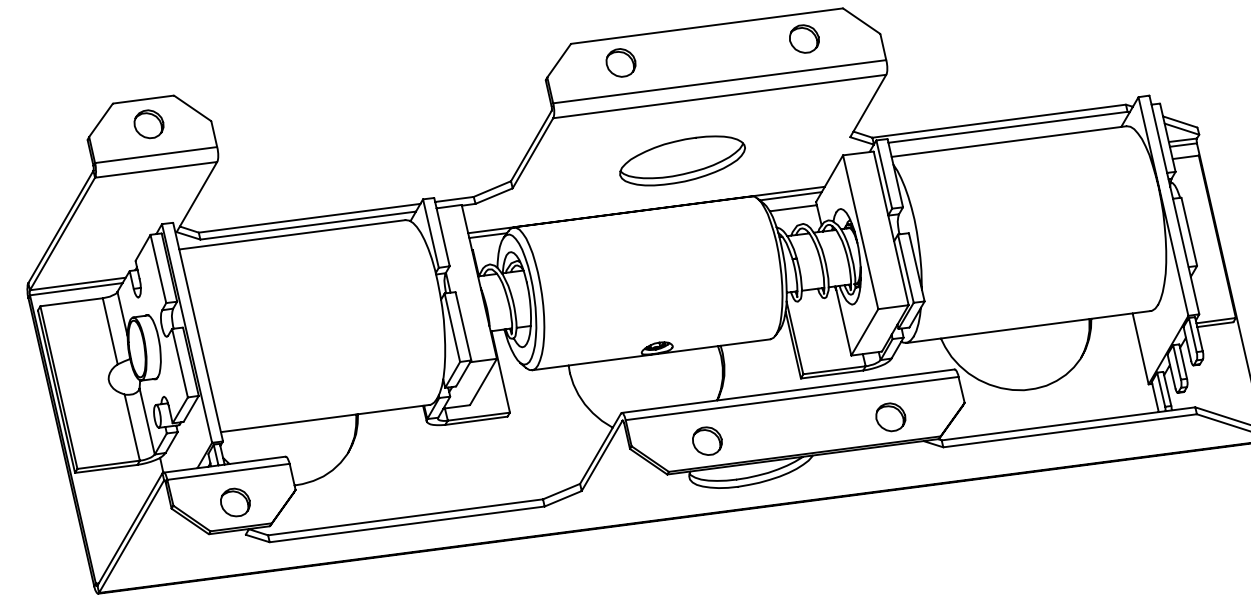

SHAKER ASSEMBLY

NOTES:
 1) SET SCREW AND LOCKNUTS SHOULD BE INSTALLED WITH RED LOCTITE 262.

RAW THRILLS INC.	
TITLE: GUN MAIN ASSEMBLY	
TOL: .X ±.030 .XX ±.015 .XXX ±.005	MATERIAL:
HOLES: +.002/-0.000	FINISH: SEE NOTES
ANGLES: ±0.5°	PART NO.
SHEET 3 of 3	REV D

REV.	DESCRIPTION	DATE
A	RELEASED	1/15/15
B	REVISED FOR CLARITY. ADDED LARGER VIEWS.	3/1/17

2) INSTALL SEGMENT GEAR AFTER POT IS ALIGNED FOR EASIER ACCESS TO GEAR SET SCREW. THE CENTER OF THE SEGMENT GEAR SHOULD POINT TO THE CENTER OF THE POT AS SHOWN.

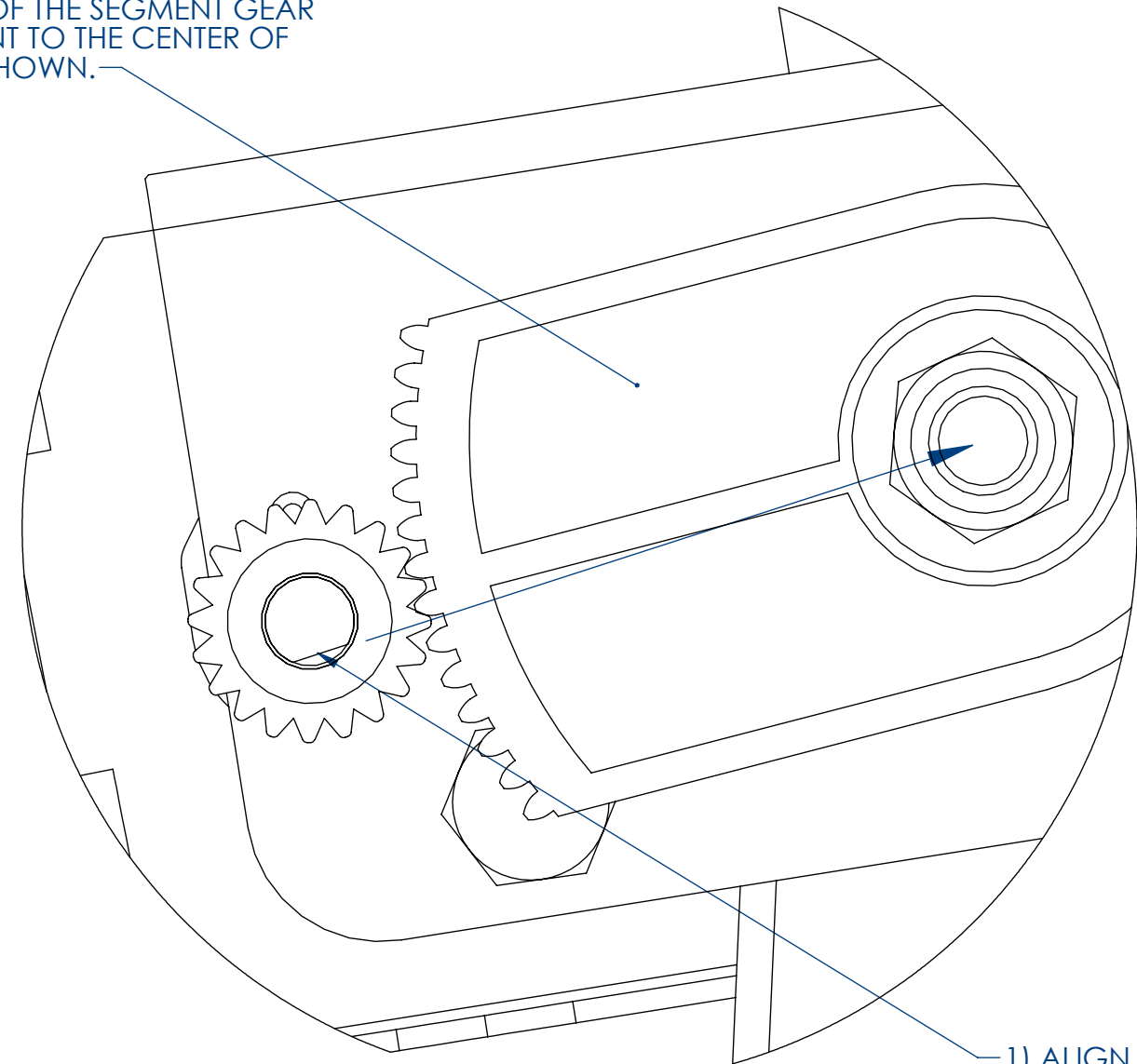

DETAIL A
SCALE 2 : 1

1) ALIGN FLAT ON POT DOWNWARD AND POINTING TOWARD CENTER OF SEGMENT GEAR

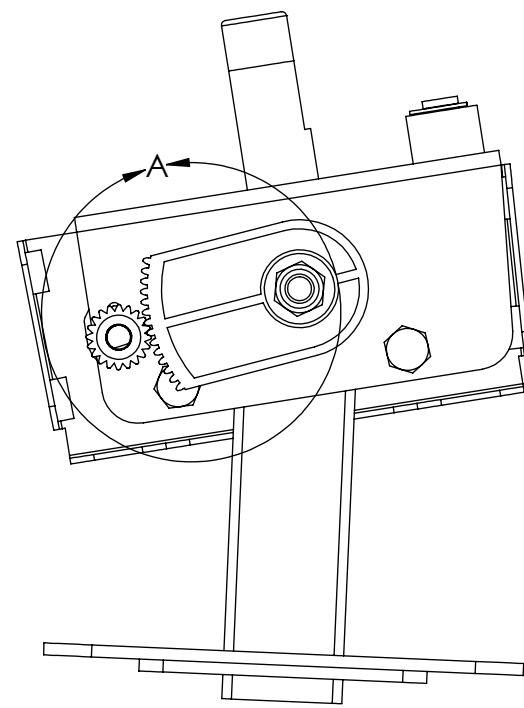

INSTALL WITH A 1/16"(.063") GAP

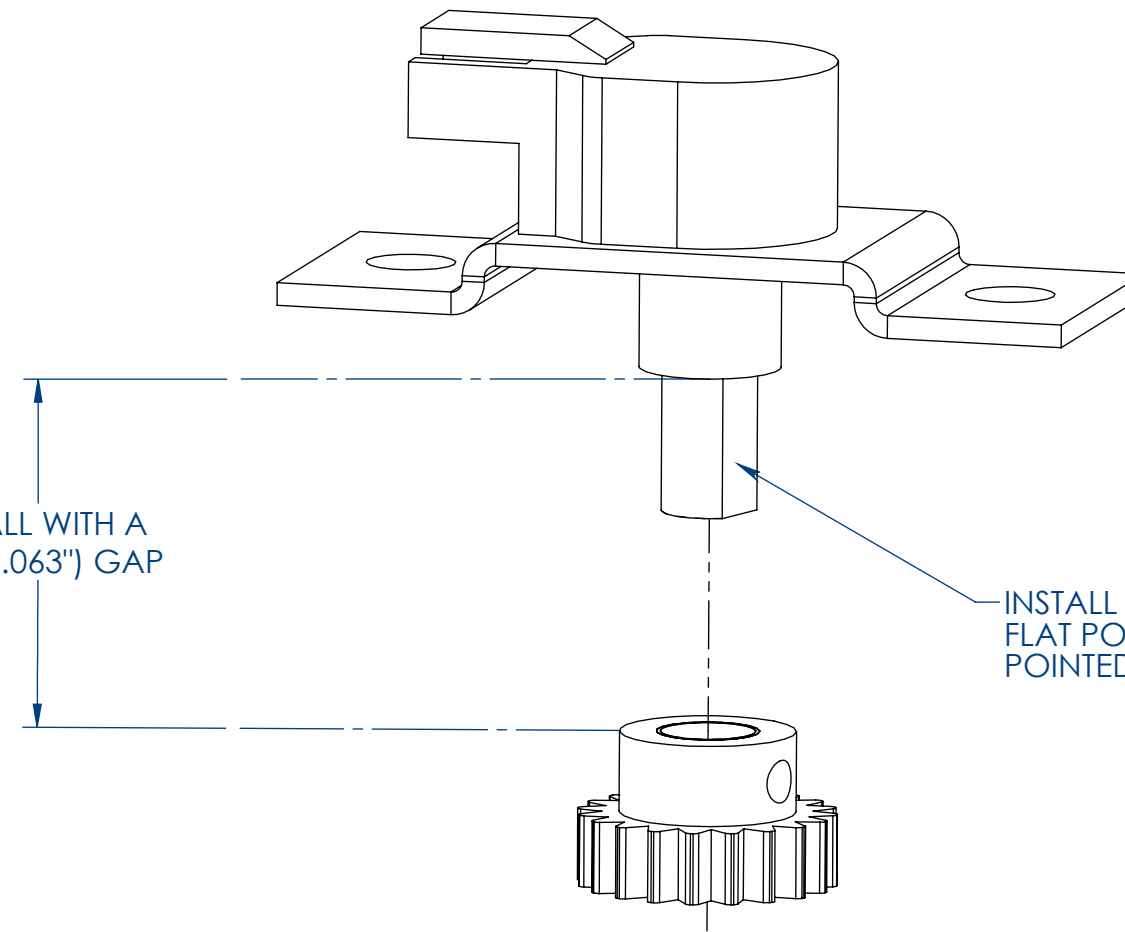

DETAIL B
SCALE 2 : 1

INSTALL ASSEMBLY WITH GEAR INSTALLED AND POT FLAT POINTING TOWARD HANDLES WITH HANDLES POINTED STRAIGHT FORWARD.

MAKE SURE THAT THE HANDLES ARE POINTED STRAIGHT FORWARD DURING POT INSTALLATION

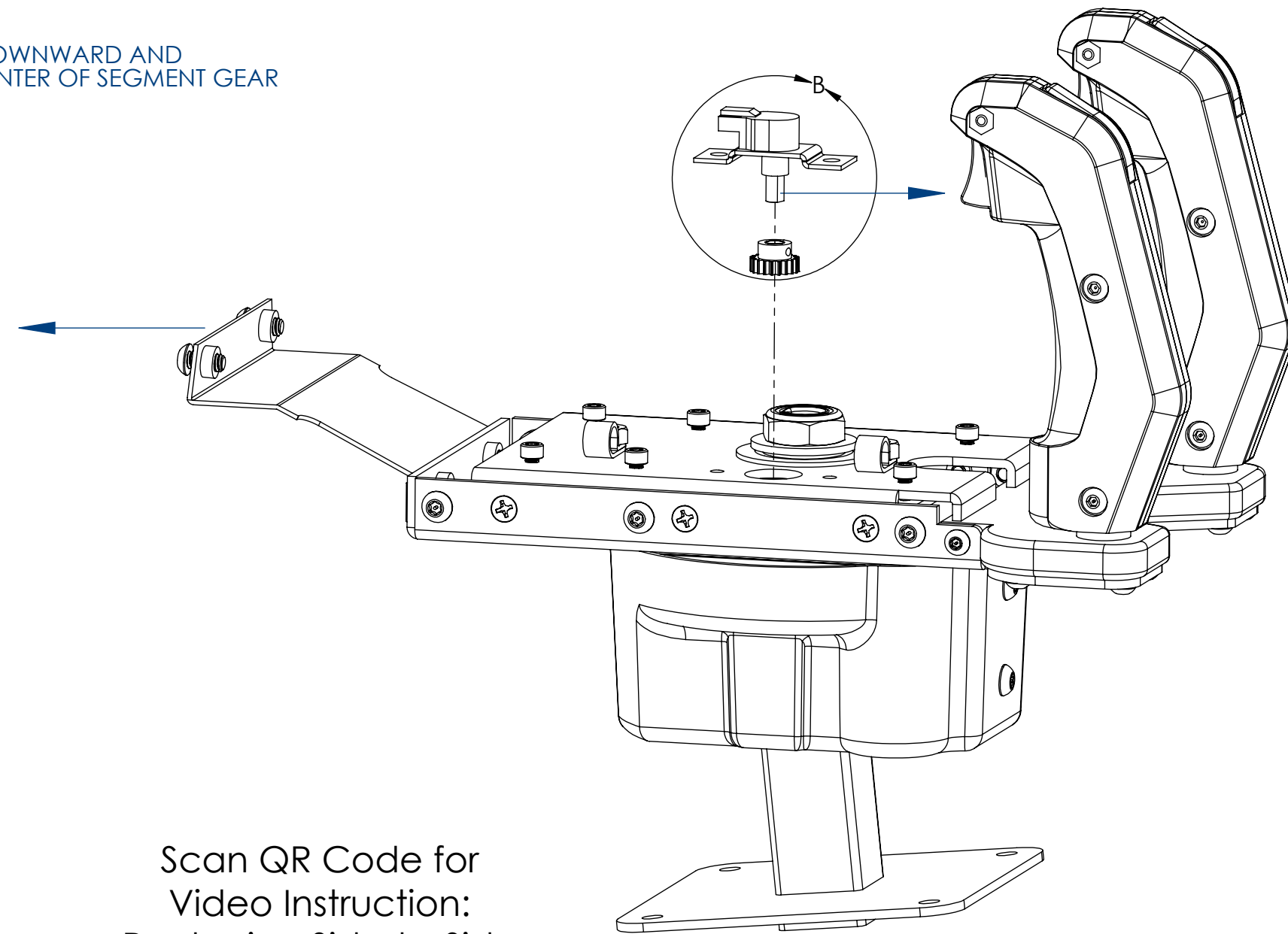

Scan QR Code for Video Instruction:
Replacing Up/Down Potentiometer
youtu.be/eO9afzAdQGw



UP AND DOWN POT ALIGNMENT

Scan QR Code for Video Instruction:
Replacing Side-to-Side Potentiometer
youtu.be/8AGiy0Ljlw8



LEFT TO RIGHT POT ALIGNMENT

RAW THRILLS INC.

TITLE: POT ALIGNMENT DRAWING

TOL: .X ±.030
.XX ±.015
.XXX ±.005

HOLES: +.002/-0.000

ANGLES: ±0.5°

SHEET 1 of 1

MATERIAL: SEE NOTES

FINISH: SEE NOTES

PART NO.

REV

B

REV.	DESCRIPTION	DATE
A	RELEASED	11/17/15
B	CORRECTED PART NUMBERS	12/14/16
C	CORRECTED HAPP PART NUMBER ON ITEM #5	5/10/19

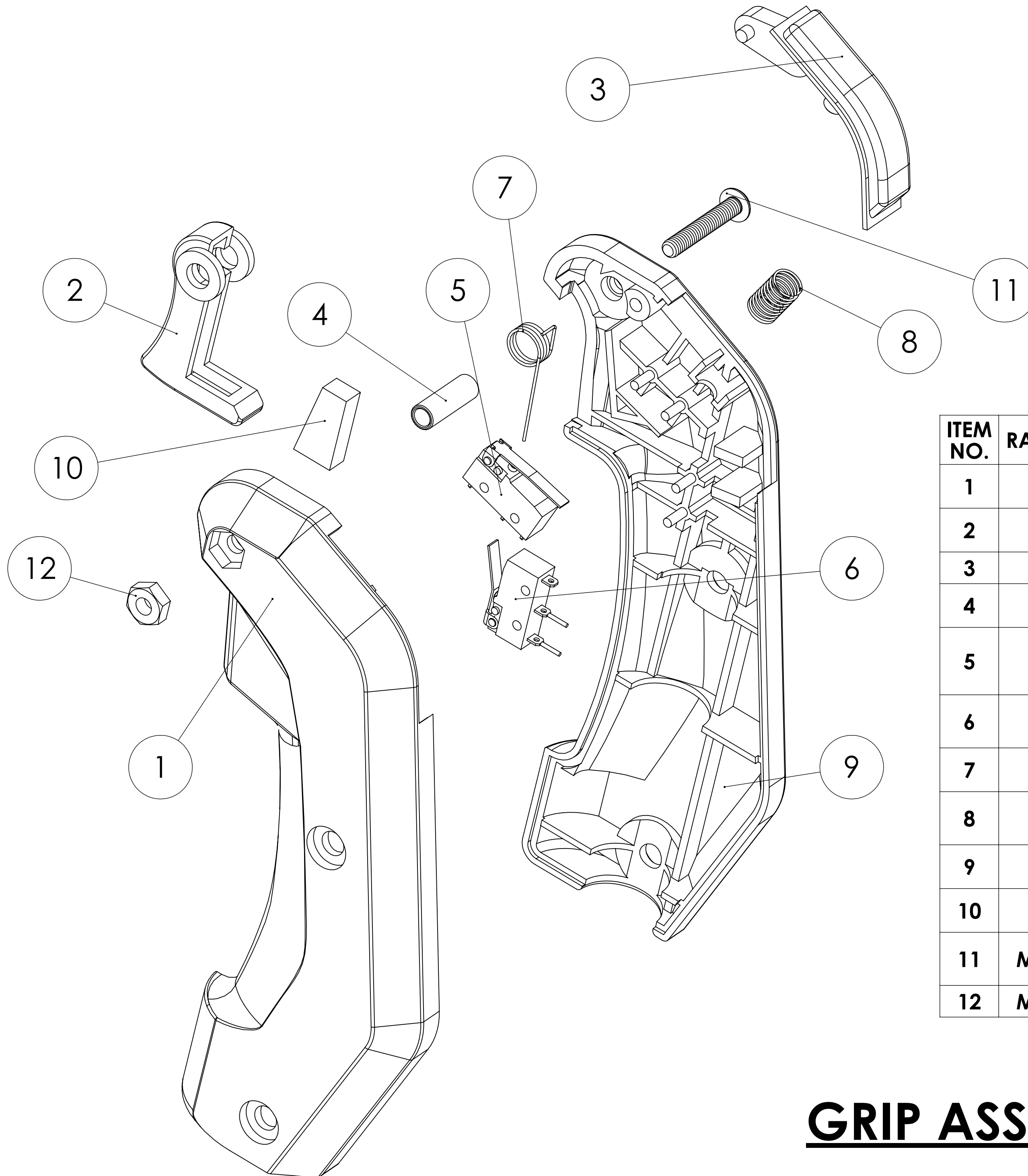

ITEM NO.	RAW PART NUMBER	HAPP NUMBER	DESCRIPTION	QTY.
1	608-00201-01	95-1294-00	GRIP, LEFT HALF	1
2	608-00204-01	95-1295-00	TRIGGER, RED	1
3	608-00203-01	95-1439-00	LARGE THUMB BUTTON	1
4	608-00205-01	95-1315-00	SHAFT, TRIGGER	1
5	608-00215-01	95-0259-ST	SWITCH ASSY FOR THUMB SWITCH	1
6	608-00220-01	95-0028-00	SWITCH ASSY. FOR TRIGGER	1
7	608-00206-01	95-1297-00	SPRING, TORSION	1
8	608-00207-01	95-1298-00	SPRING, COMPRESSION	1
9	608-00202-01	95-1293-00	GRIP, RIGHT HALF	1
10	608-00218-01	96-0110-00	TRIGGER BUMPER	1
11	MMC 96075A147	43-0378-00	SCREW, #8-32 x 1 TP BLACK	1
12	MMC 86537A140	43-1124-00	HEX NUT #8-32 BLACK	1

GRIP ASSEMBLY

RAW THRILLS INC.	
TITLE:	JP GRIP ASSEMBLY
TOL: .X ±.030 .XX ±.015 .XXX ±.005	MATERIAL:
HOLE: +.002/-0.000	FINISH: SEE NOTES
ANGLE: ±0.5°	PART NO.
SHEET 1 of 1	REV C

REV.	DESCRIPTION	DATE
A	RELEASED	10/18/14
B	REVISED	1/9/15
C	NO CHANGE THIS SHEET	12/14/16
D	ADDED UPPER VACFORM PART NUMBER AND CORRECTED FRONT VACFORM BRACKET IMAGE	5/10/19
E	NO CHANGES THIS SHEET	3/17/20

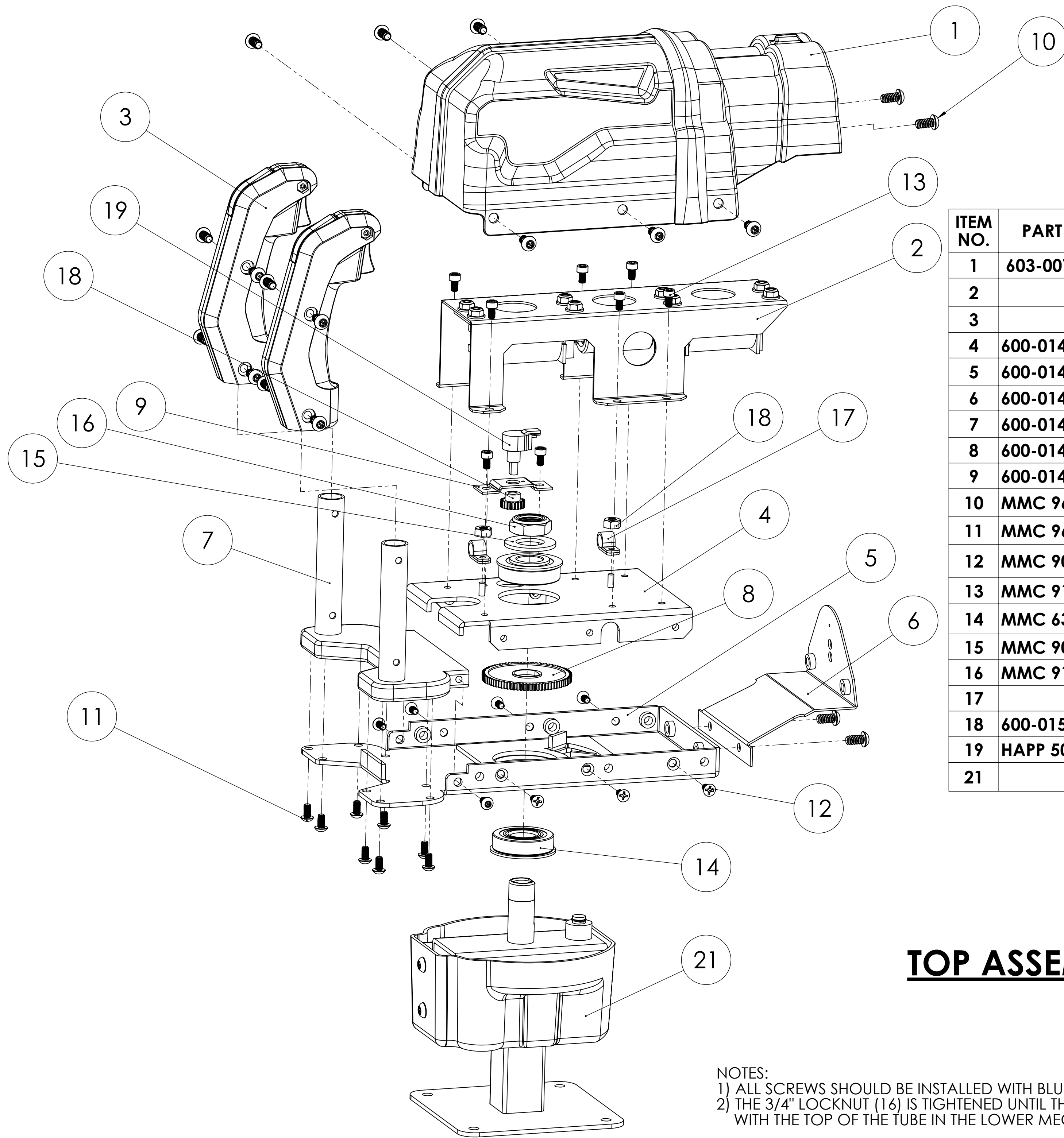

ITEM NO.	PART NUMBER	DESCRIPTION	QTY.
1	603-00755-01	UPPER VACFORM	1
2		SHAKER ASSEMBLY	1
3		GRIP ASSEMBLY	2
4	600-01422-01	PIN PLATE	1
5	600-01423-01	COVER BRACKET	1
6	600-01495-01	FRONT VACFORM BRACKET	1
7	600-01411-01	GRIP PLATE WELDMENT	1
8	600-01420-01	LARGE GEAR	1
9	600-01491-01	POT BRACKET	1
10	MMC 96075A211	1/4-20 X 1/2" BLK TP SCREW	18
11	MMC 96075A183	10-32 X 3/8" BLK TP SCREW	10
12	MMC 90273A827	10-32 X 3/8" FLAT HEAD SCREW	6
13	MMC 91251A337	10-32 X 5/16" CAP SCREW	8
14	MMC 6384K369	3/4" FLANGED BEARING	2
15	MMC 90126A036	3/4" WASHER	1
16	MMC 91342A240	3/4" LOCKNUT	1
17		CABLE CLAMP	2
18	600-01567-01	SMALL POT GEAR	1
19	HAPP 50-2670-01	POT - 5K	1
21		LOWER MECH ASSEMBLY	1

TOP ASSEMBLY

NOTES:
 1) ALL SCREWS SHOULD BE INSTALLED WITH BLUE LOCTITE 242 or 243.
 2) THE 3/4" LOCKNUT (16) IS TIGHTENED UNTIL THE TOP IS FLUSH WITH THE TOP OF THE TUBE IN THE LOWER MECH ASSEMBLY (21).

RAW THRILLS INC.	
TITLE: GUN MAIN ASSEMBLY	
TOL: .X ±.030 .XX ±.015 .XXX ±.005	MATERIAL:
HOLES: +.002/-0.000 ANGLES: ±0.5°	FINISH: SEE NOTES
SHEET 1 of 3	PART NO. _____ REV E

REV.	DESCRIPTION	DATE
A	RELEASED	10/18/14
B	REVISED	1/9/15
C	CHANGED TO MOLDED LOWER COVER	12/14/16
D	CORRECTED NOTE #2	5/10/19
E	DELETED ITEM #3	3/17/20

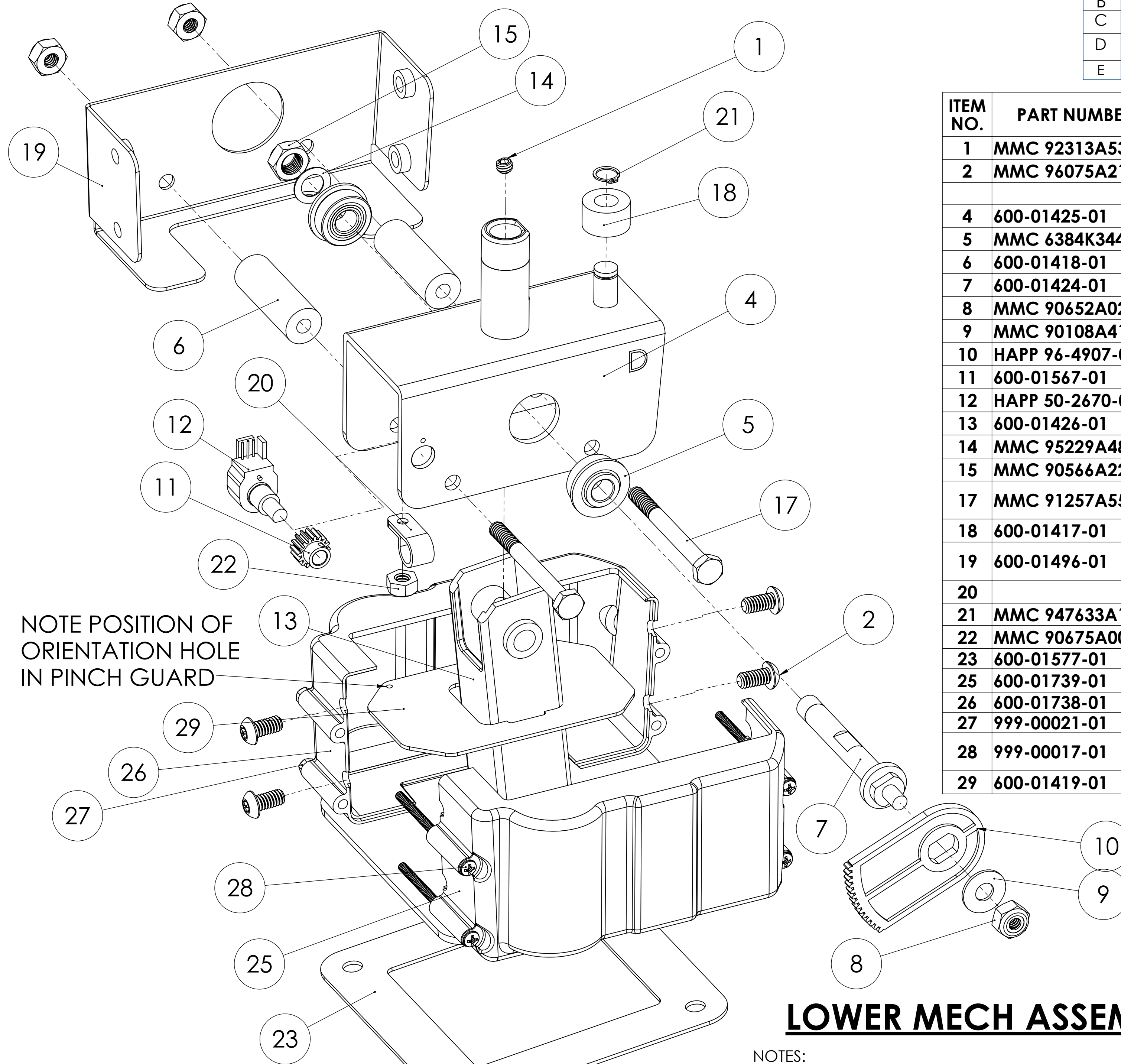

NOTE POSITION OF ORIENTATION HOLE IN PINCH GUARD

ITEM NO.	PART NUMBER	DESCRIPTION	QTY.
1	MMC 92313A532	1/4-20 x 3/16" SET SCREW	1
2	MMC 96075A211	1/4-20 X 1/2" BLK TP SCREW	4
4	600-01425-01	ROCKER BRACKET	1
5	MMC 6384K344	3/8" FLANGED BEARING	2
6	600-01418-01	TUBE STOP BUMPER - 5/8" OD	2
7	600-01424-01	SIDE PIN	1
8	MMC 90652A029	1/4-20 THIN LOCKNUT	3
9	MMC 90108A413	1/4-20 WASHER	1
10	HAPP 96-4907-00	SEGMENT GEAR	1
11	600-01567-01	POT GEAR	1
12	HAPP 50-2670-01	POT - 5K	1
13	600-01426-01	LOWER TUBE WELDMENT	1
14	MMC 95229A480	3/8" WASHER	1
15	MMC 90566A220	3/8" THIN LOCKNUT	1
17	MMC 91257A552	1/4-20 x 2 1/2 HEX HEAD - GRADE 8	2
18	600-01417-01	SHORT STOP BUMPER - 3/4" OD	1
19	600-01496-01	LOWER VACFORM MOUNTING BRACKET	1
20		CABLE CLAMP	1
21	MMC 947633A170	RETAINING CLIP	1
22	MMC 90675A009	8/32" KEPS NUT	1
23	600-01577-01	GUN ISOLATOR	1
25	600-01739-01	BOTTOM COVER - RIGHT	1
26	600-01738-01	BOTTOM COVER - LEFT	1
27	999-00021-01	6-32 HEX LOCKNUT - BLACK	4
28	999-00017-01	6-32 X 2.5" PHILLIPS HEAD SCREW - BLACK	4
29	600-01419-01	PINCH COVER	1

LOWER MECH ASSEMBLY

- NOTES:
 1) ALL SCREWS SHOULD BE INSTALLED WITH BLUE LOCTITE 242 or 243.
 2) PEEL AND STICK GUN ISOLATOR (#23) TO BOTTOM OF LOWER TUBE WELDMENT (#13)

RAW THRILLS INC.	
TITLE:	GUN MAIN ASSEMBLY
TOL: .X ±.030 .XX ±.015 .XXX ±.005	MATERIAL:
HOLES: +.002/-0.000	FINISH: SEE NOTES
ANGLES: ±0.5°	PART NO.
SHEET 2 of 3	REV E

REV.	DESCRIPTION	DATE
A	RELEASED	10/18/14
B	REVISED	1/9/15
C	NO CHANGE THIS SHEET	12/14/16
D	NO CHANGE THIS SHEET	5/10/19
E	ADDED RAW THRILLS PART NUMBER TO ITEM #9	3/17/20

ITEM NO.	PART NUMBER	DESCRIPTION	QTY.
1	600-01576-01	COIL MOUNT BRACKET	4
2	600-01412-01	COIL BRACKET	1
3	608-00216-01	COIL FL11629	2
4	600-01413-01	COIL ROD	1
5	600-01414-01	COIL WEIGHT	1
6	MMC 91375A535	1/4-20 x 3/8" SET SCREW	1
7	680-00214-01	BLUE DAMPER PAD	2
8	608-00210-01	COIL SPRING	2
9	608-00218-01	COIL SLEEVE	2
10	MMC 93298A109	10-32 FLANGED LOCKNUT	8

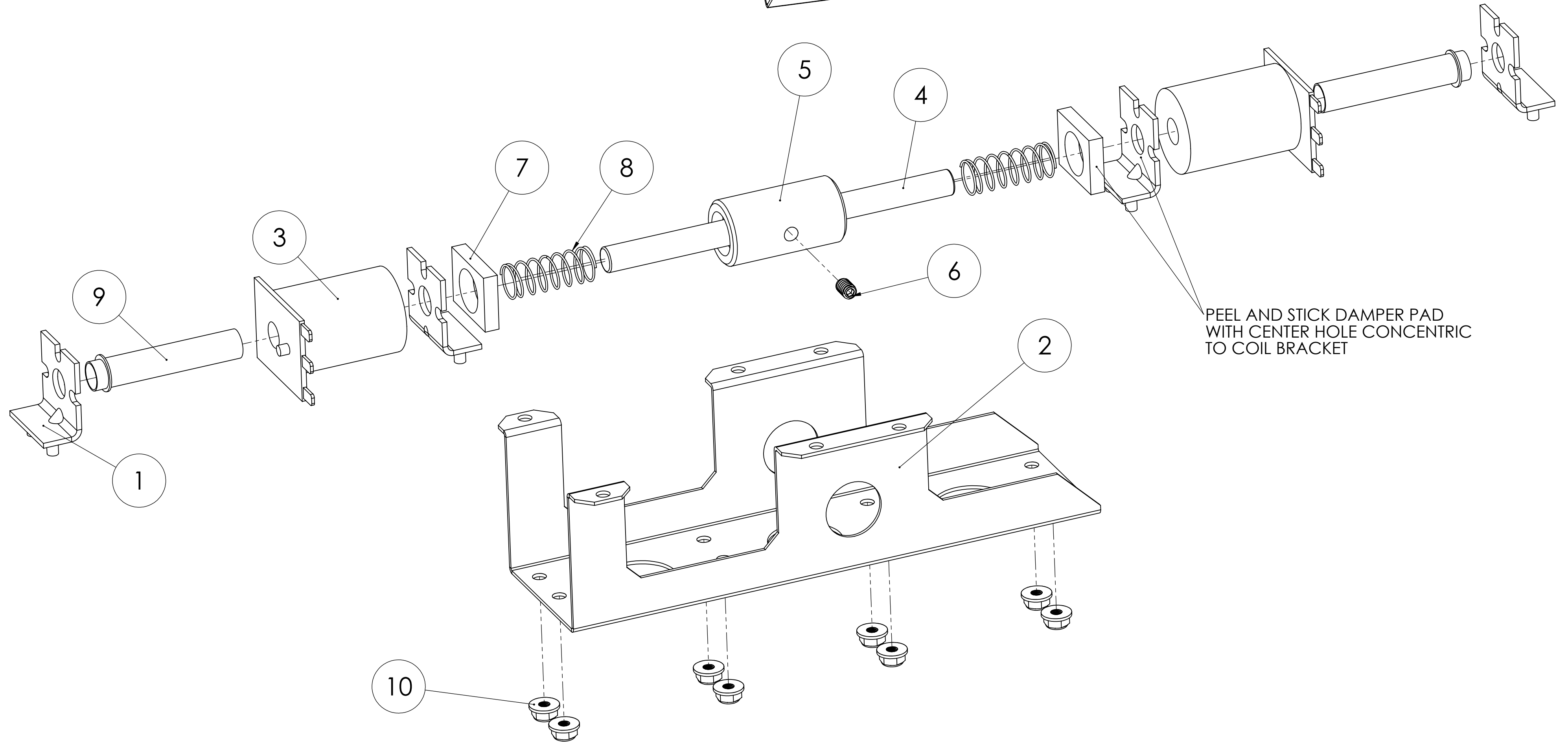
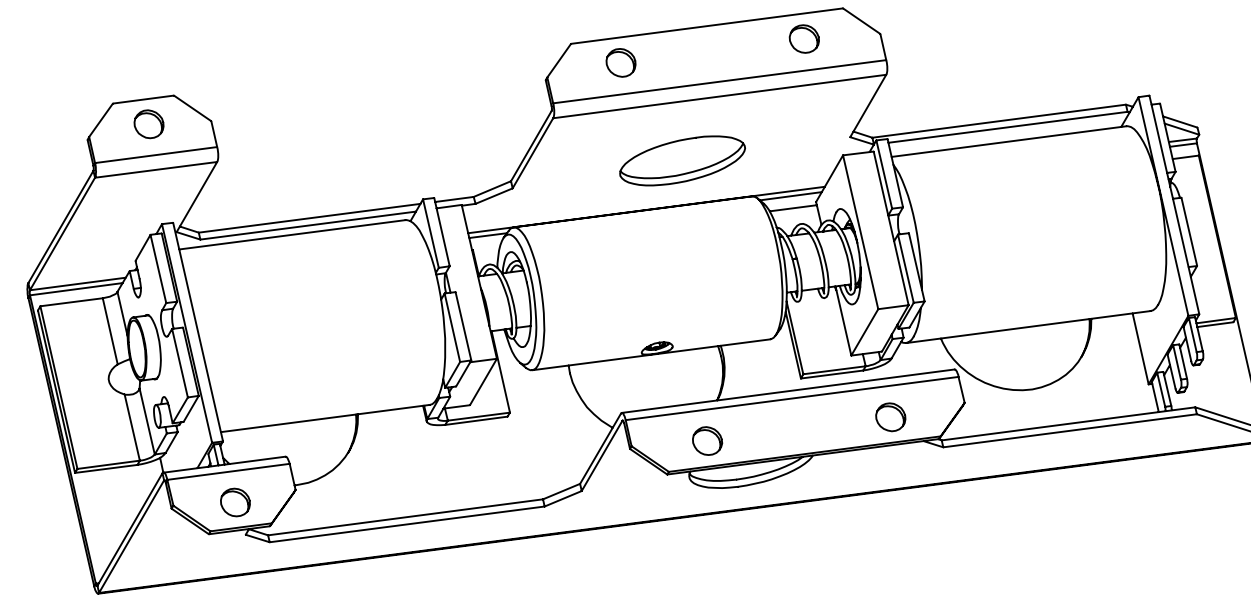

SHAKER ASSEMBLY

NOTES:

1) SET SCREW AND LOCKNUTS SHOULD BE INSTALLED WITH RED LOCTITE 262.

RAW THRILLS INC.	
TITLE: GUN MAIN ASSEMBLY	
TOL: .X ±.030 .XX ±.015 .XXX ±.005	MATERIAL:
HOLES: +.002/-0.000	FINISH: SEE NOTES
ANGLES: ±0.5°	PART NO.
SHEET 3 of 3	REV E

**MAIN HARNESS :
CA-4516**

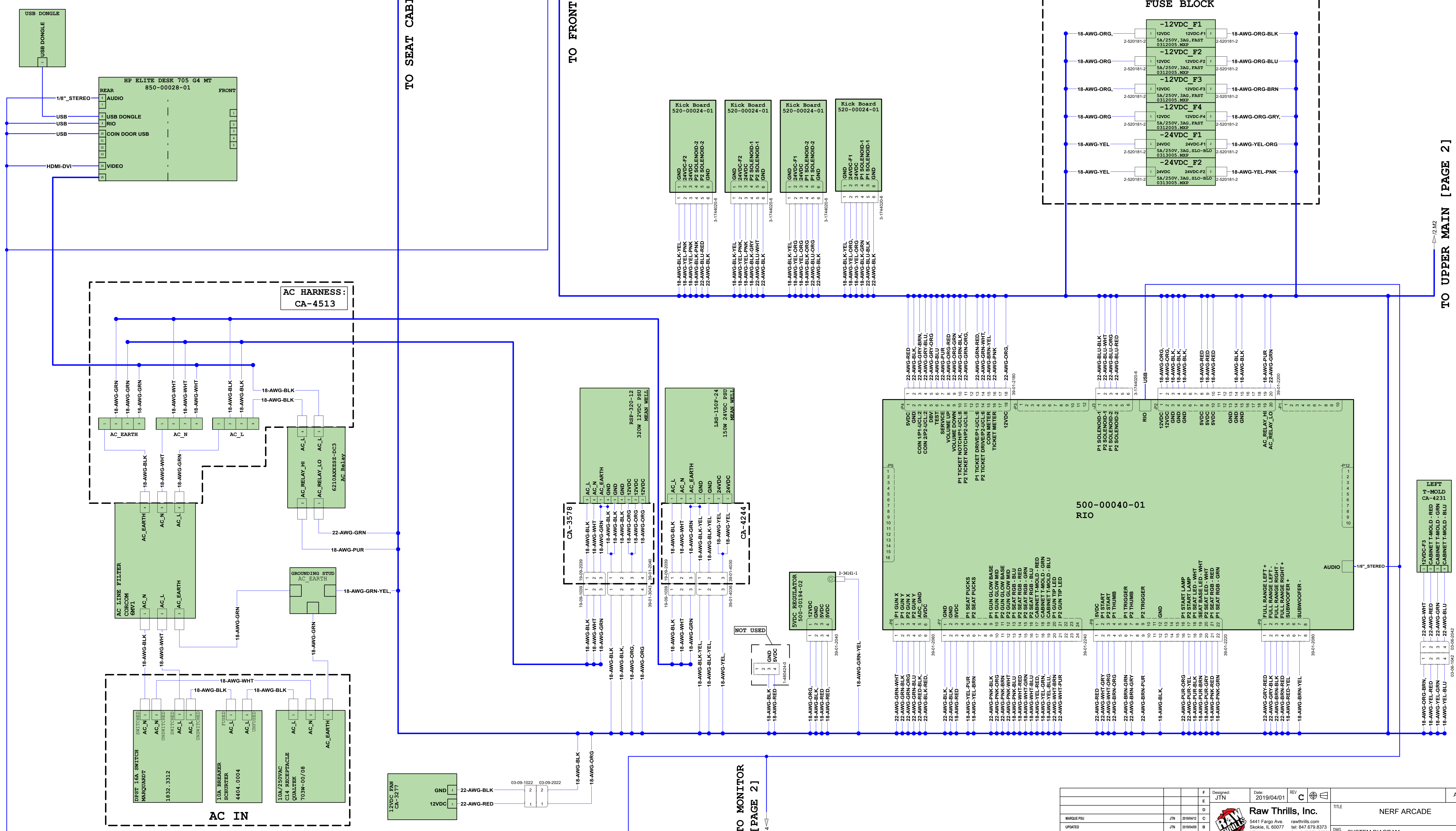

TO SEAT CABINET [PAGE 3]

TO FRONT MAIN [PAGE 2]

TO UPPER MAIN [PAGE 2]

TO MONITOR [PAGE 2]

<table border="1"> <tr><td>REV</td><td>DATE</td><td>BY</td><td>DESCRIPTION</td></tr> <tr><td>1</td><td>2019/04/01</td><td>JTN</td><td>INITIAL</td></tr> <tr><td>2</td><td>2019/04/01</td><td>JTN</td><td>UPDATED</td></tr> <tr><td>3</td><td>2019/04/01</td><td>JTN</td><td>DESCRIPTION</td></tr> </table>	REV	DATE	BY	DESCRIPTION	1	2019/04/01	JTN	INITIAL	2	2019/04/01	JTN	UPDATED	3	2019/04/01	JTN	DESCRIPTION	<p>Designed: JTN</p> <p>Date: 2019/04/01</p> <p>REV: C</p> <p>Raw Thrills, Inc.</p> <p>5441 Fargo Ave. Skokie, IL 60077 tel: 847.679.8373 fax: 847.679.8538</p>	<p>TITLE: NERF ARCADE</p> <p>DWG: SYSTEM DIAGRAM</p> <p>SHEET 1</p> <p>SHEETS 3</p>	<p>ANSI D</p>
REV	DATE	BY	DESCRIPTION																
1	2019/04/01	JTN	INITIAL																
2	2019/04/01	JTN	UPDATED																
3	2019/04/01	JTN	DESCRIPTION																

FRONT MAIN

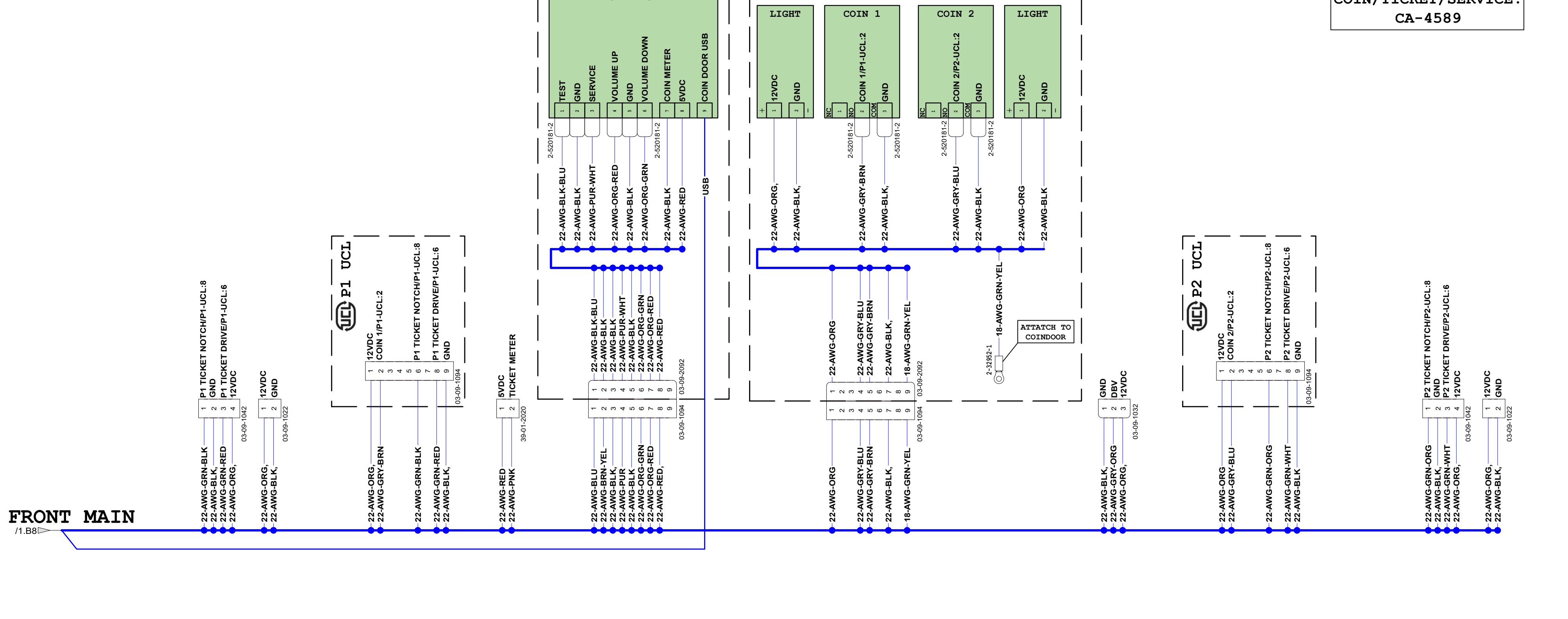

UPPER MAIN

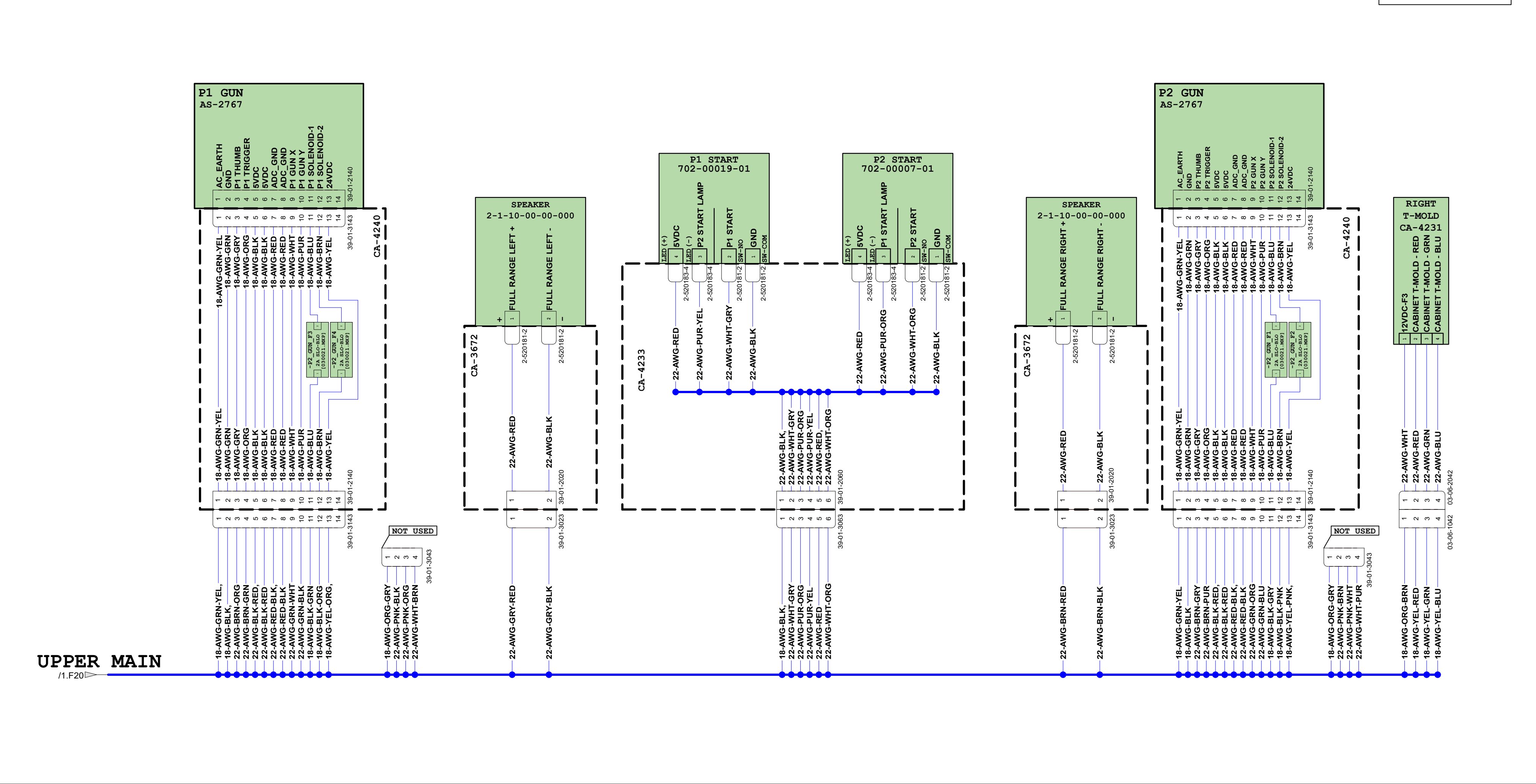

MONITOR

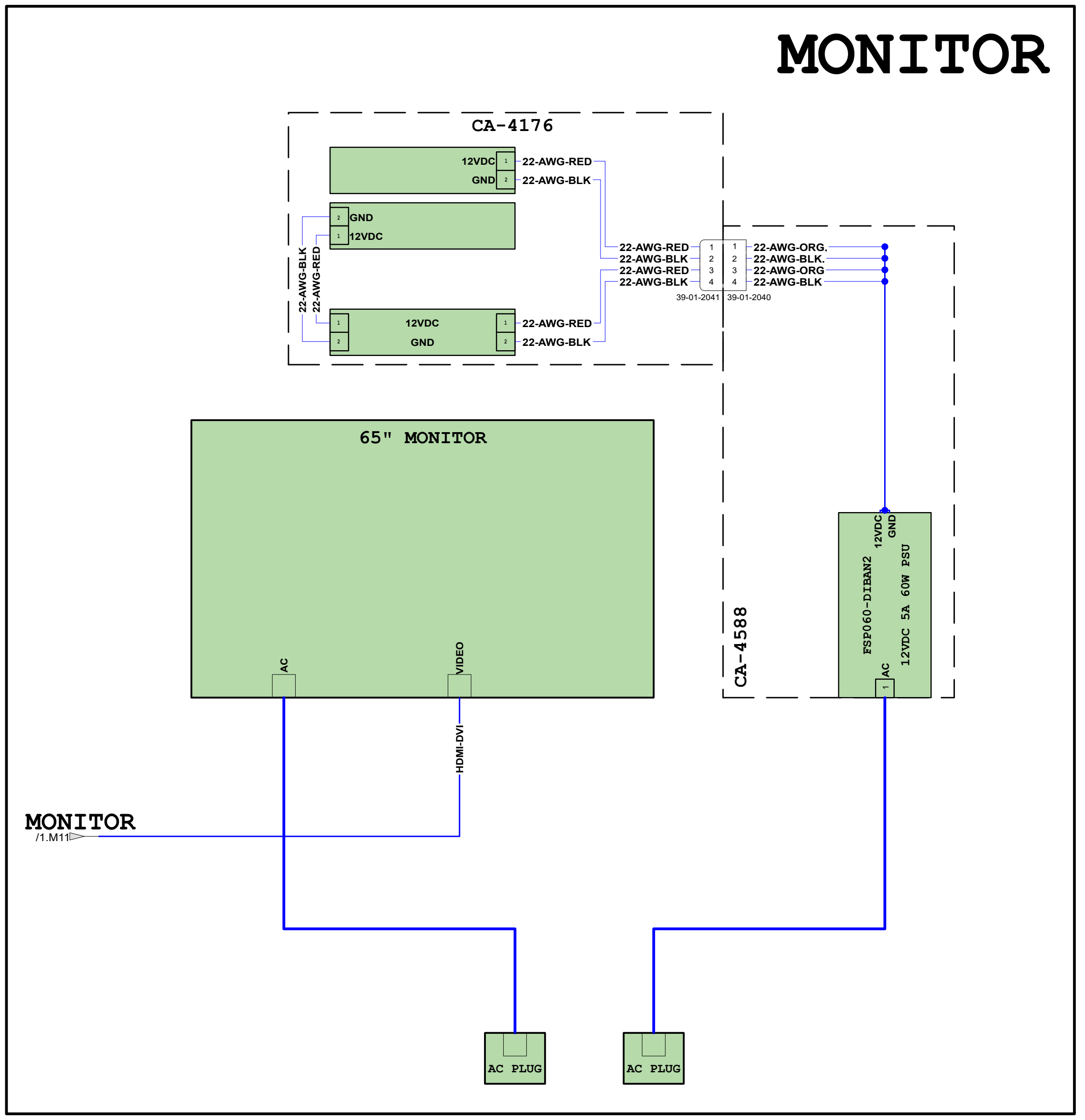

DESIGNED BY	JTN	DATE	2019/04/01	REV	C	ANSI D
INITIAL	JTN	DATE	2019/04/01	REV	A	
DESCRIPTION	NERF ARCADE					
Raw Thrills, Inc. 5441 Fargo Ave. Skokie, IL 60077 USA rawthrills.com tel: 847.679.8373 fax: 847.679.8538						TITLE NERF ARCADE DWG SYSTEM DIAGRAM SHEET 2 SHEETS 3

PLAYER 1 SEAT

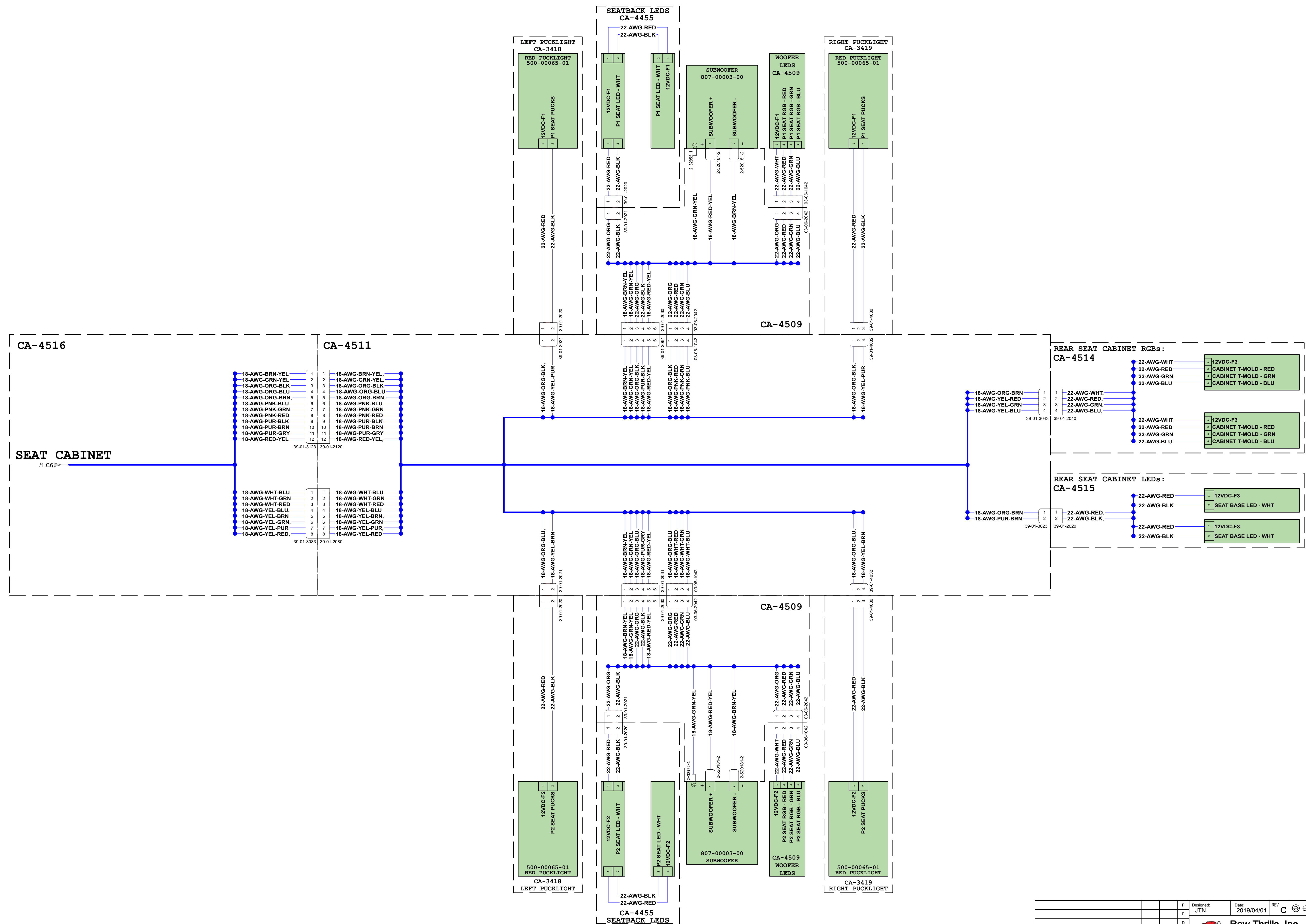

PLAYER 2 SEAT

DESIGNED	JTN	DATE	2019/04/01	REV	C	ANSI D
DATE	JTN	2019/04/01				
INITIAL	JTN	2019/04/01				
DESCRIPTION		BY	JTN	DATE	REV	

Raw Thrills, Inc.
 5441 Fargo Ave.
 Skokie, IL 60077
 USA
 rawthrills.com
 tel: 847.679.8373
 fax: 847.679.8538

TITLE	NERF ARCADE	
DWG	SYSTEM DIAGRAM	
SHEET	3	SHEETS 3

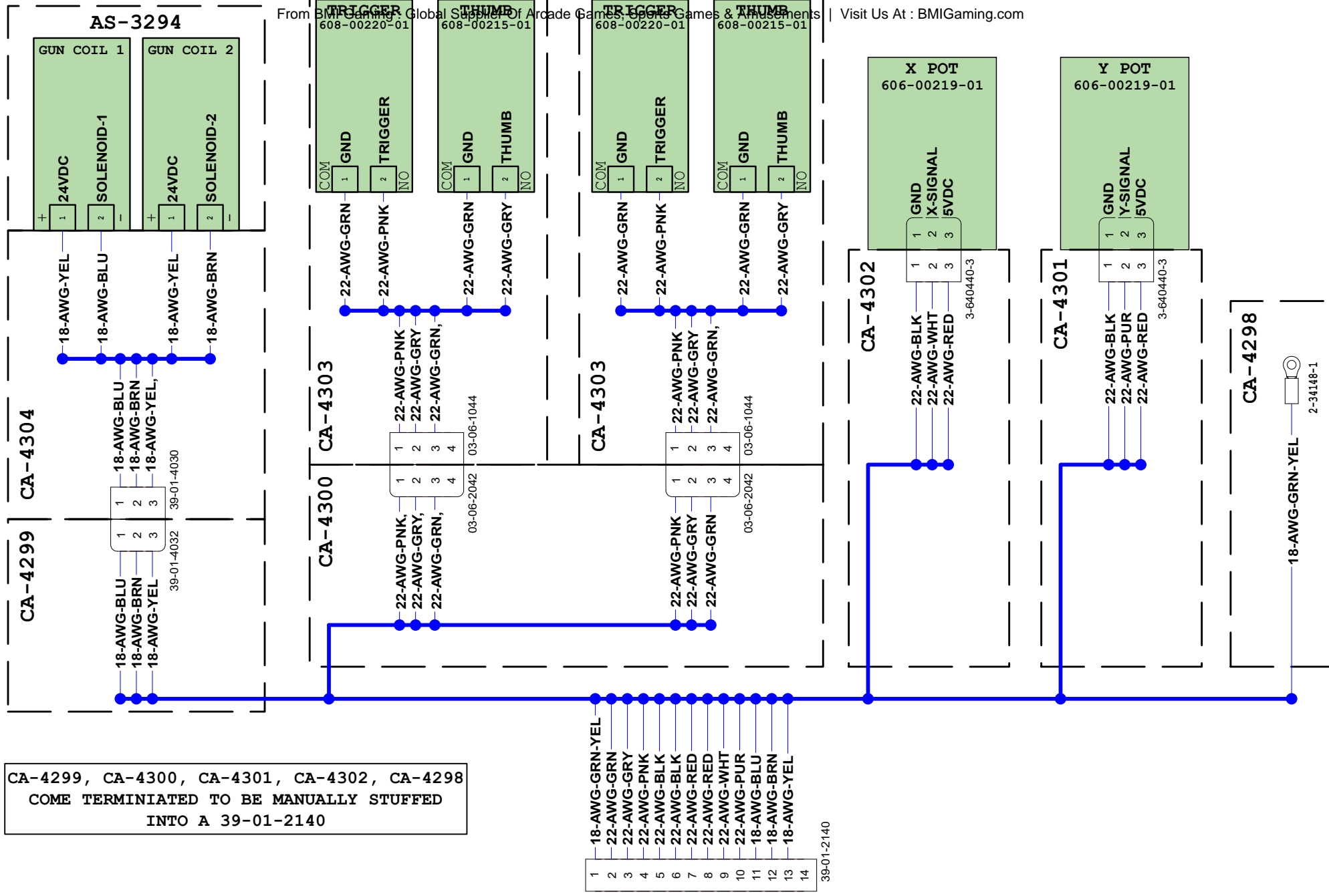

CA-4299, CA-4300, CA-4301, CA-4302, CA-4298
 COME TERMINATED TO BE MANUALLY STUFFED
 INTO A 39-01-2140

				F	Designed: JTN	Date: 2019/04/05	REV C	ANSI A	
				E	 Raw Thrills, Inc. 5441 Fargo Ave. Skokie, IL 60077 USA rawthrills.com tel: 847.679.8373 fax: 847.679.8538				TITLE JURASSIC PARK GUN: 604-00039-01
				D					DWG SYSTEM DIAGRAM
NOTE ADD	JTN	2019/04/09	C	SHEET 1					SHEETS 1
POT SIGS	JTN	2019/04/09	B						
INITIAL	JTN	2019/04/05	A						
DESCRIPTION	BY	DATE	REV						