

Super Bikes™ 3 Operator's Manual



**SUPER
BIKES 3**



Yamaha, the Tuning Fork Mark, R6 and likeness thereof including the color Yamaha Blue, Niken and the likeness thereof, MT-10 and the likeness thereof are trademarks of Yamaha Motor used under license.

Software™ & © 2019 Raw Thrills, Inc. All Rights Reserved.

This Page Left
Blank
Intentionally

Super Bikes™ 3

Table of Contents

Safety	5
Operation	5
Transporting.....	5
Handling Components	5
Disconnect Power	5
Grounding	5
Electrical Shocks.....	5
Monitor	5
Power Cord	5
Surge Suppressor	5
Water and Other Liquid Sources.....	6
Connectors	6
Computer	6
Tempered Glass Warning.....	6
Hazard to Epileptics	6
Manual	6
Specifications	6
Product Specifications	7
Electrical Power	7
Temperature	7
Humidity.....	7
Dimensions.....	7
Fuse Replacement Guide	7
Setup	8
Unpack Materials	8
Cabinet Assembly.....	9
Card Reader Installation and Setup	10
Check Electrical Settings	11
Startup Game	11
Diagnostic and Adjustments	12
Basic Functional Test on Initial Power Up.....	13

Super Bikes™ 3

Test Menus.....	14
Main Menu.....	14
Diagnostics	15
Pricing Adjustments Cash.....	16
Pricing Adjustments Tokens.....	17
Pricing Adjustments Swipes	18
Game Settings	19
System Settings.....	20
Audits	21
Resets.....	22
Volume.....	23
Calibration.....	24
Utilities.....	25
System Information.....	26
Choosing the Right Pricing Adjustments for Your Location	27
PC Hardware	28
PC Hard Drive Recovery	29
Troubleshooting	30
Technical Support.....	34
Electrical and Mechanical Illustrations.....	35

Super Bikes™ 3

Safety

Operation

Before operating game, read this manual. Failure to properly install and operate this game could result in malfunction or accident. Operate the game in accordance with the manual.

Transporting

The cabinet is very heavy. Because the monitor is high, the cabinet is also very top-heavy. Use appropriate care when moving or transporting cabinet. It contains fragile glass and electronic components. Avoid rough handling.

Handling Components

Many components are extremely sensitive to handling, environmental and Electrostatic Discharge (ESD) events—especially the computer. Do not handle it roughly. Before servicing, call your distributor and inquire about the PC warranty. Use proper ESD procedures when servicing. Protect components from harmful environmental conditions, such as extreme temperatures, excessive moisture or other damaging effects.

Disconnect Power

Always turn the power off and unplug the unit before servicing or making adjustments unless otherwise instructed. Installing or repairing components while power is on can damage the components and void the warranty.

Grounding

Avoid electrical shock. Do not plug in AC power until you have inspected and properly grounded the unit. Only plug into a grounded, three-wire outlet. Do not use a “cheater” plug or cut off the ground pin on the line cord.

Electrical Shocks

There is no isolation transformer in the cabinet. Disconnect AC power before servicing. However, be aware that lethal voltages can remain in the electronic components even when AC power is disconnected. Use extreme caution when servicing. Verify that there is a working ground connection. If the unit sustains water damage, cease using it immediately and unplug AC power.

Monitor

The monitor contains no user serviceable parts. Do not attempt to service the monitor.

Power Cord

If the power cord is damaged or lost, replace it with an identical cord as supplied by the manufacturer or an authorized service agent.

Surge Suppressor

It is recommended that you plug your game’s power cord into a surge suppressor to help protect from power surges that may damage sensitive electronic components.

Super Bikes™ 3

Water and Other Liquid Sources

Do not install game near sprinkler or other water jet sources. Do not use water jet to clean game. Keep minimum clearance behind game and wall for proper ventilation but also prevent access of liquid from spills and sprays from entering ventilation holes.

Connectors

When servicing machine, ensure all connectors mate properly. If connectors do not slip in easily, do not force them. Connectors are often keyed and only connect one way. Check for correct orientation.

Computer

The computer contains sensitive components, including a hard drive. Do not handle it roughly. Call your distributor before servicing its internal components. Ask about warranty information as it relates to the PC. Cycle AC power on or off with the cabinet power switch.

A dongle has been inserted into one of the USB ports. This is required for game play.

Do not remove the dongle except for troubleshooting purposes.

Tempered Glass Warning

When handling the LCD display glass cover take special care and set the glass down softly on a flat surface free of debris. The edge of the glass is sensitive to hard impact. Shattered glass from the monitor can travel long distances and cause bodily injury. Use proper procedures when handling broken materials.

Hazard to Epileptics

A small portion of the population has an epileptic condition that may cause seizures. Affected persons experience seizure while watching some television pictures or playing certain video games. People who have not had seizures may still have an undetected epileptic condition. If anyone in your family has experienced epilepsy symptoms (seizures or loss of awareness), consult your physical before using video games. While children play video games, a parent should observe. Be alert to the following symptoms: dizziness, altered vision, eye or muscle twitching, involuntary movements, loss of awareness, disorientation or convulsions. If you or your child experiences these symptoms, discontinue use immediately and consult your physician.

Manual

Keep this manual available and ready for use. If the game fails to function properly, turn off the machine and unplug the AC line cord. Contact your local distributor. You may not reproduce this document or any of its contents without written authorization from Raw Thrills, Inc.

Specifications

For reasons such as performance, this product's specifications may change without notice. Federal patent, copyright and other intellectual property laws protect the content, devices and design of the game and its equipment.

Super Bikes™ 3

Product Specifications

Electrical Power

United States, International and Japan

Operating AC Current: 5/2.5 AMPS

Voltage: 115/230~VAC 50/60Hz

Temperature

50° F to 104° F

(10° C to 40° C)

Humidity

Must not exceed 95% relative humidity

Dimensions

Cabinet:

Height: 79.17"

Depth: 32.80"

Width: 45.19"

Bike:

Height: 39.34"

Depth: 68.42"

Width: 35.43"

Fully assembled on location:

Height: 98.25"

Depth: 84.625"

Width: 45.19"

Approximate weight: 660lbs

Fuse Replacement Guide

NOTE: FOR CONTINUED PROTECTION AGAINST
FIRE AND ELECTRICAL DAMAGE, USE ONLY
SPECIFIED FUSE TYPE AND VALUE.

Please see unit for specified fuse labeling. Abbreviations:

5A 250V	5A, 250VAC Fast Acting 3AG Fuse	Littlefuse 031205.MXP (or equivalent)
---------	---------------------------------	---------------------------------------

Super Bikes™ 3

Setup

Unpack Materials

1. Place the shipping crate(s) on a flat, stable surface.
2. Cut the banding straps and remove the cardboard lids.
3. Lift off the large cardboard containers surrounding the cabinet assembly and remove any shipping cleats.
4. Remove the coin door key from the coin return slot.
5. Open the top coin door.
6. Locate the keys for the back door and the cash box door.
7. Open the cash box door and remove the cash box.
8. Check for shipping damage to the following:
 - Marquee and monitor
 - Cabinet decals
9. Check the AC line cord for visible signs of damage.

Pay particular attention to the plug and line cord insulation.

Super Bikes™ 3

Cabinet Assembly

Note: 2 people are required, and ladders are recommended. Marquee assembly is **top heavy and can tip over!**

1. Place cabinet in desired floor location. Remove upper back door and carefully place such that it will not fall over or be damaged. Setup ladders next to the cabinet for marquee installation.
2. Locate the marquee assembly as well as the following hardware:
 - a. (5) black tamper proof Torx machine screws, ¼ - 20 thread, 1-1/2" long
 - b. (5) ¼" black split lock washers
 - c. (5) ¼" black flat washers
3. Using a T-27 bit, securely mount the marquee assembly atop the cabinet as shown in the assembly setup diagram, avoiding any pinching/crushing of the wire harness which should pass through the access hole. Connect marquee harness to cabinet harness.
4. Connect internal wire harness from inside the main cabinet to bike assembly manually.
5. Locate the bike assembly as well as the following hardware:
 - a. (4) black tamper proof Torx machine screws, ¼ - 20 thread, 1-1/2" long
 - b. (4) ¼" black split lock washers
 - c. (4) ¼" black flat washers
6. Push bike assembly into rectangular opening and using a T-27 bit, secure the bike assembly to the cabinet as shown in the assembly setup diagram, avoiding any pinching/crushing of the wire harness which should pass through the access hole.
7. Remove the shipping screws located under the bike assembly. One is located on each underside of the bike. Once removed store the screws for safe keeping for future use (cash box is a good place).

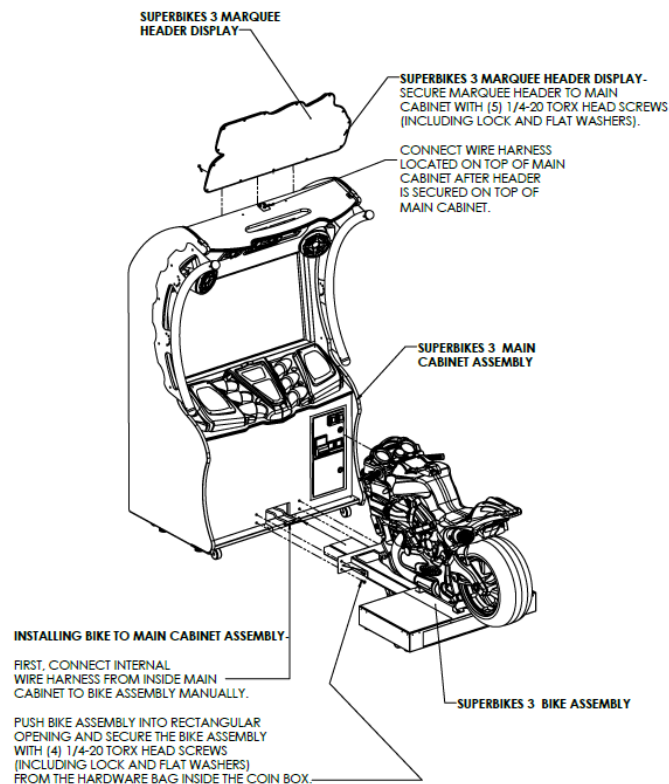

Super Bikes™ 3

Card Reader Installation and Setup

Due to the rising popularity of aftermarket debit card systems for cashless or coinless operation of amusement machines (i.e. Embed, Intercard, Semnox), this Super Bikes 3 cabinet is equipped with UCL compatible harnessing to ensure that the installation process is easier and less prone to miswiring.

It is recommended that the card reader be mounted to the coin door, using either the provided UCL connector.

UCL, or Universal Card Link, is a debit card standard established by the American Amusement Machine Association. Visit <https://coin-op.org/standardization/> for the latest UCL standard and manual information.

The UCL connections on the game use pins 1, 2, 6, 8, and 9. The other pins are unused. Each UCL connector can supply up to 1A at 12VDC.

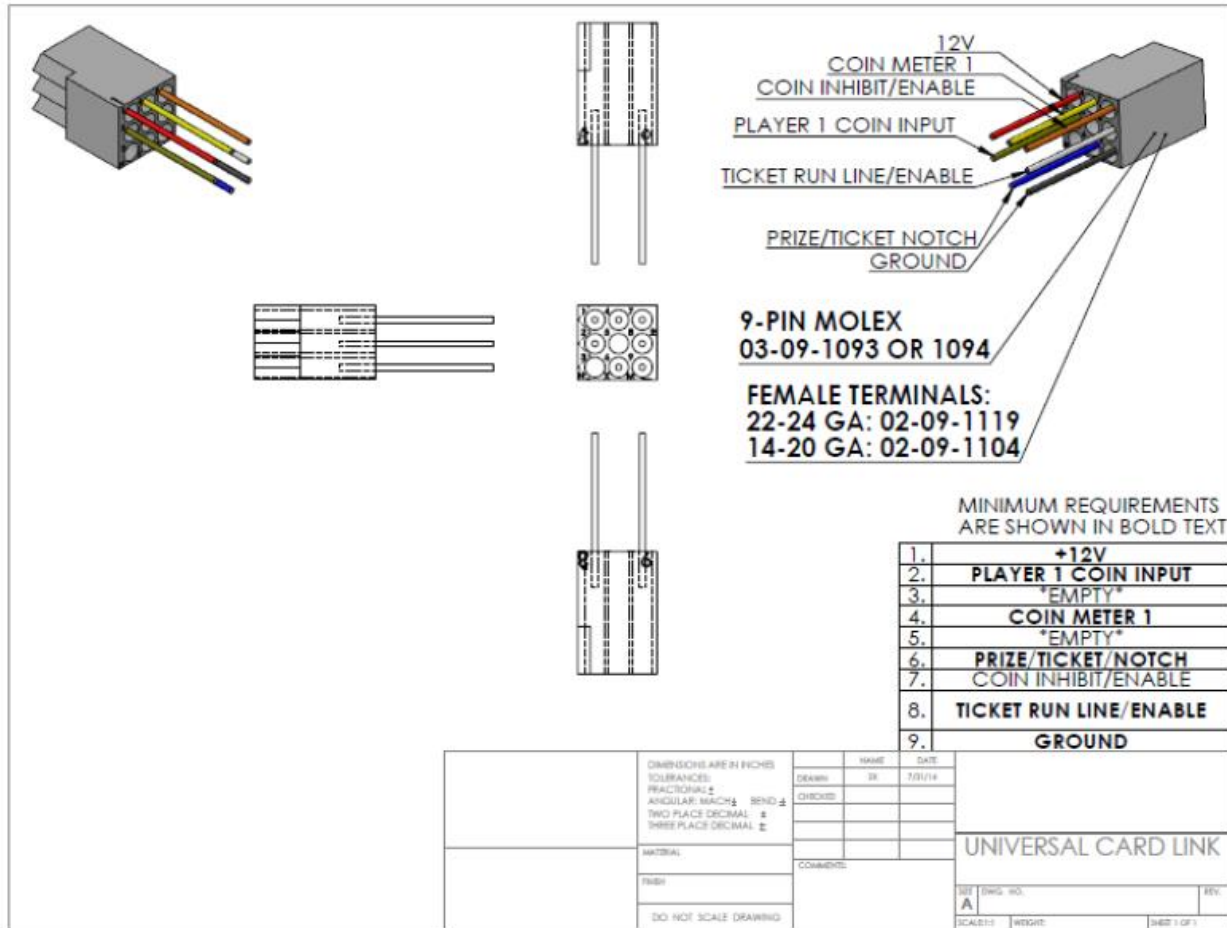

Super Bikes™ 3

Check Electrical Settings

1. Verify the voltage in the nearest AC outlet.
2. Verify the AC outlet ground connection is present and working.

Startup Game

1. Plug the line cord into an AC outlet.
2. Turn the main cabinet power switch on.
3. Verify the game and all components are operating normally. See *Basic Functional Test on Initial Power Up* in the *Diagnostics and Adjustments* section for the recommended procedure.

Super Bikes™ 3

Diagnostic and Adjustments

The Service Button Panel has four buttons, three of which can navigate the menu system.

The control panel buttons and joysticks/guns can also advance through test menu screens.

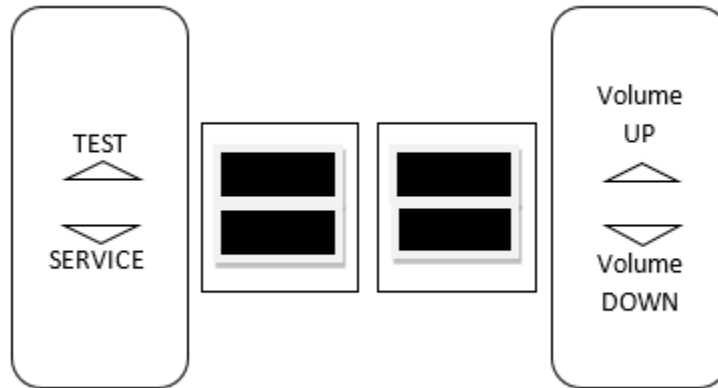

Navigating the Test Menu	
Button	Action
TEST (Not in Test Menu)	Enters Test Menu
TEST (In Test Menu)	Selects Highlighted Option
SERVICE (On Main Menu)	Exits Test Menu
SERVICE (Not on Main Menu)	Cancel Selection
VOLUME UP	Move Up
VOLUME DOWN	Move Down
Start Buttons	Selects Highlighted Option

An on-screen message acknowledges changes or when you exit a selection without making a change.

Super Bikes™ 3

Basic Functional Test on Initial Power Up

1. Enter the Input Test and verify all switch inputs are working.
2. Enter the Monitor Test and verify the monitor is working properly.
3. Enter the Sound Test and verify the audio works and is not distorted.
4. Enter the Light Test and verify that all the lights are working properly.
5. Enter the Coin Meter Test and verify the coin meter is working properly.
6. Enter the Watchdog Test and verify the game reboots.
7. Upon a successful reboot, you are ready to adjust pricing, volume and other functions.

Super Bikes™ 3

Test Menu

Main Menu

Choose from all available operator settings and menus here. You can use the test menu bracket and volume buttons to navigate. The View, Tunes, and Start buttons as well as the brake are also available to use for easier navigation through these menus.

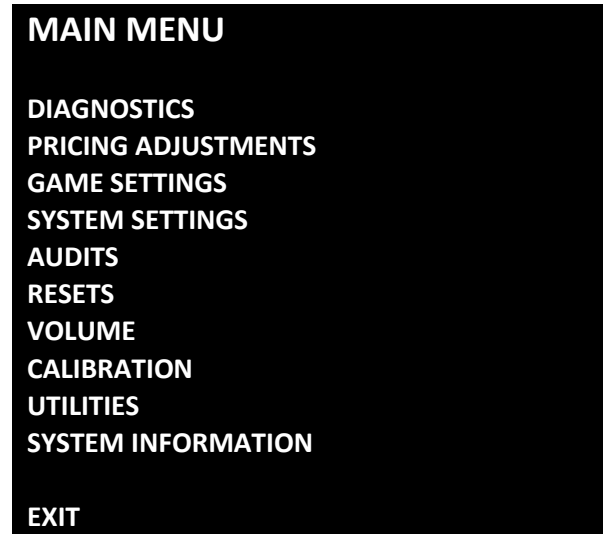

Super Bikes™ 3

Diagnostics

This menu allows all game functions to be verified or diagnosed. You can improve collections by periodically verifying proper game function and operation. This includes periodic Hard Drive checks to verify that software has not been corrupted or reporting an error.

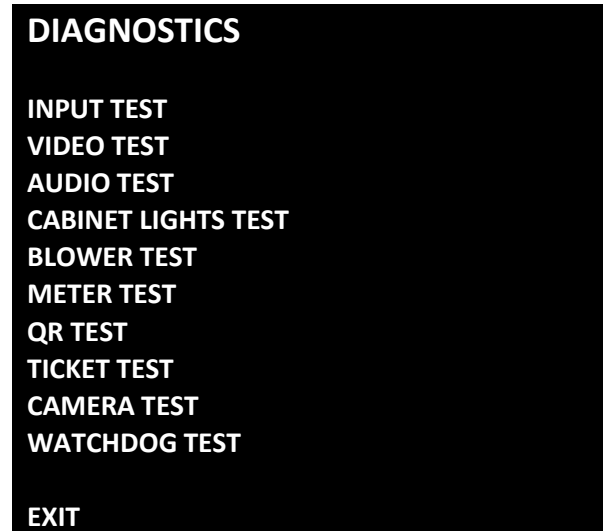

- **Input Test**: Test input hardware such as switches.
- **Video Test**: Cycle through full screen colors on the monitor.
- **Audio Test**: Test audio using 100HZ and 1000HZ test.
- **Cabinet Lights Test**: Tests all LED cabinet lighting together and individually.
- **Blower Test**: Test the blower motor.
- **Meter Test**: Test the functionality of the mechanical coin meter inside the cabinet.
- **QR Test**: Test view QR codes to send info to Raw Thrills.
- **Ticket Test**: Test the functionality of the ticket mech.
- **Camera Test**: Test the functionality of the camera.
- **Watchdog Test**: Test the functionality of the watchdog reset.

Super Bikes™ 3

Pricing Adjustments Cash

Set pricing adjustments. There are three options to choose from: cash, token, and swipes.

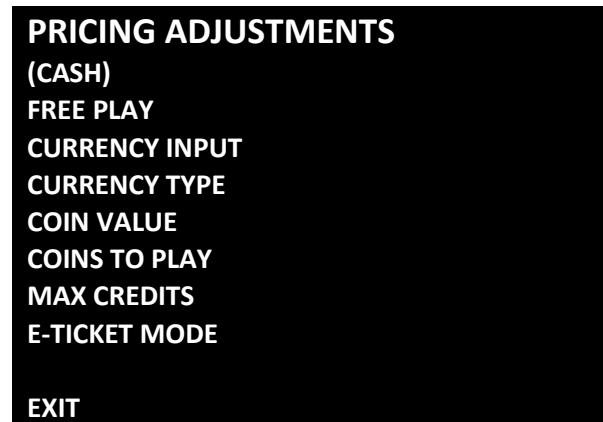

- **Free Play:** Turn free play mode on or off (default off).
- **Currency Input:** Change the currency input. Choose between, cash, tokens, and swipes.
- **Currency Type:** Change the currency type.
- **Coin Value:** Change the money value of the coin.
- **Coins to Play:** Adjust the amount of coins per credit.
- **Max Credits:** Adjust the maximum number of credits.
- **E-Ticket Mode:** Turn E-Tickets on or off (default off). When on adjust ticket payout for 1st through 4th place finishers.

Super Bikes™ 3

Pricing Adjustments Tokens

Set pricing adjustments. There are three options to choose from: cash, token, and swipes.

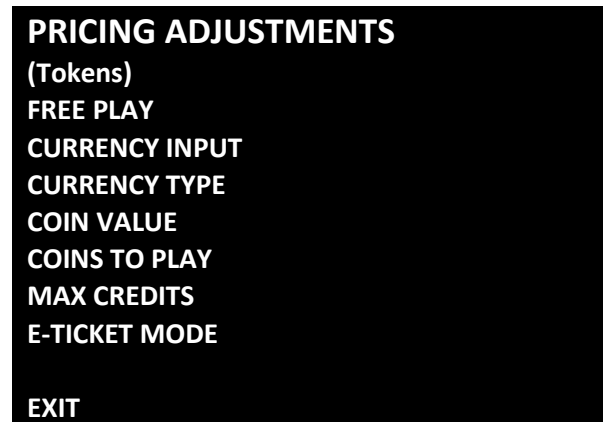

- **Free Play:** Turn free play mode on or off (default off).
- **Currency Input:** Change the currency input. Choose between, cash, tokens, and swipes.
- **Currency Type:** Change the currency type.
- **Coin Value:** Change the money value of the token.
- **Coins to Play:** Adjust the amount of tokens per credit.
- **Max Credits:** Adjust the maximum number of credits.
- **E-Ticket Mode:** Turn E-Tickets on or off (default off). When on adjust ticket payout for 1st through 4th place finishers.

Super Bikes™ 3

Pricing Adjustments Swipes

Set pricing adjustments. There are three options to choose from: cash, token, and swipes.

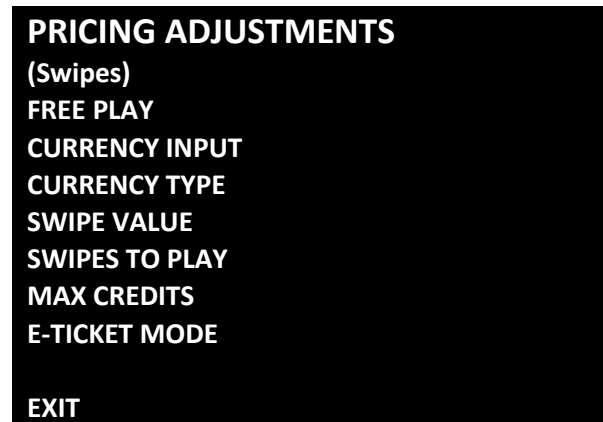

- **Free Play:** Turn free play mode on or off (default off).
- **Currency Input:** Change the currency input. Choose between, cash, tokens, and swipes.
- **Currency Type:** Change the currency type.
- **Swipe Value:** Change the money value of the swipe.
- **Swipes to Play:** Adjust the amount of swipes per credit.
- **Max Credits:** Adjust the maximum number of credits.
- **E-Ticket Mode:** Turn E-Tickets on or off (default off). When on adjust ticket payout for 1st through 4th place finishers.

Super Bikes™ 3

Game Settings

This menu allows for customization of game settings.

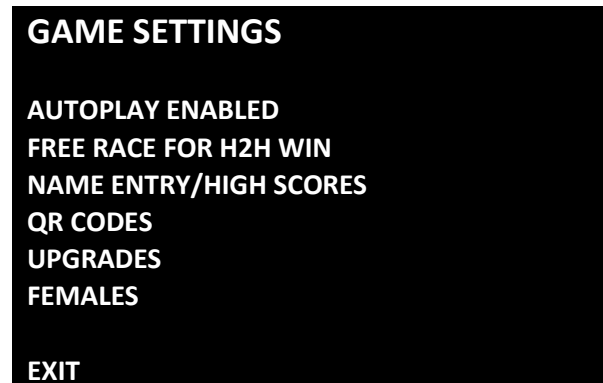

- **Autoplay Enabled**: Turn on or off (default off). When on games will play automatically.
- **Free Race for H2H Win**: Turn on or off (default off). When on the winner of a head to head race against another player will receive a free race.
- **Name Entry/High Scores**: Turn on or off (default on). When on players may enter their name and show high scores after finishing a race.
- **QR Codes**: Turn on or off (default off). When on the venue and location must be set. This allows players to scan a QR code after race to share their high scores on social media sites.
- **Upgrades**: Turn on or off (default on). When on this allows the players to purchase upgrades before the start of a race.
- **Females**: Enable/disable images of women anywhere in the game.

Super Bikes™ 3

System Settings

This menu allows for customization of various system settings.

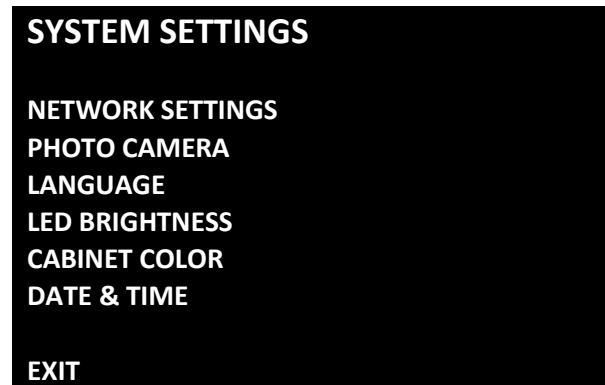

- **Network Settings**: Turn on for linked games (leave off if operating a single game).
- **Photo Camera**: Change settings for photo camera (on or off).
- **Language**: Set in game language.
- **LED Brightness**: Adjust the brightness of the cabinet LED lights.
- **Cabinet Color**: Specify the color of the cabinet plastics.
- **Date & Time**: Use to set the date and time.

Super Bikes™ 3

Audits

Audit screen help assess game performance, find intermittent problems, decide whether to adjust game difficulty and help maximize game earnings.

There are no special menu options for this test menu entry.

Super Bikes™ 3

Resets

Resets menu allows for the resetting of various machine settings and audits.

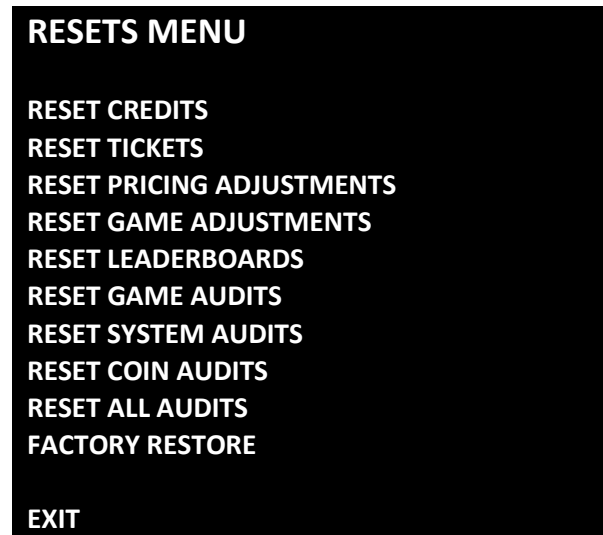

- **Reset Credits:** Reset credits to zero (0).
- **Reset Tickets:** Clears out all tickets owed on the game.
- **Reset Pricing Adjustments:** Reset all pricing settings to default.
- **Reset Game Adjustments:** Reset all game settings to default.
- **Reset Leaderboards:** Reset all high score tables.
- **Reset Game Audits:** Reset all game related audits.
- **Reset System Audits:** Reset all system audits.
- **Reset Coin Audits:** Reset all coin audits.
- **Reset All Audits:** Reset all audits.
- **Factory Restore:** Restore game to default factory settings.

Super Bikes™ 3

Volume

Volume adjustments.

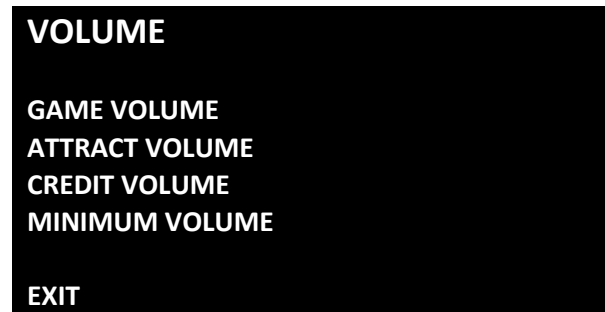

- **Game Volume**: Adjust the volume during gameplay (from 0 to 30).
- **Attract Volume**: Adjust the volume during the attract mode sequences (from 0 to 30).
- **Credit Volume**: Adjust the volume of the credit chime (from 0 to 30).
- **Minimum Volume**: Adjust the minimum volume (from 0 to 30).

Super Bikes™ 3

Calibration

Calibration of bike hardware.

There are no special menu options for this test menu entry. Follow on screen prompts to calibrate bike hardware.

Super Bikes™ 3

Utilities

Miscellaneous operator tools.

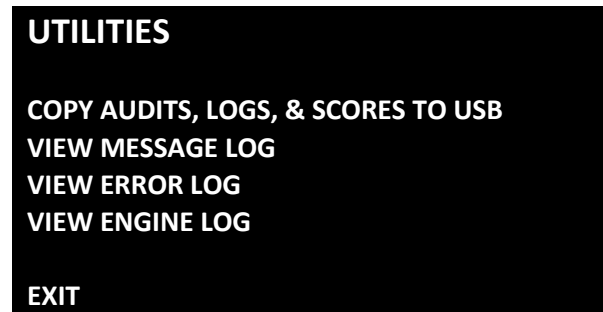

- **Copy audits, logs, & scores to USB**: Copy all audits and diagnostics to USB drive.
- **View Message Log**: Examine logged messages from the game.
- **View Error Log**: Examine error messages from the game.
- **View Engine Log**: Examine engine messages.

Super Bikes™ 3

System Information

This screen allows you to see various information about the software and hardware.

- Serial Number
- Software Revision
- Build Date
- RIO PCB
- RIO Firmware
- Dongle Version
- Cabinet Type
- Game Template

There are no special menu options for this test menu entry.

Super Bikes™ 3

Choosing the Right Pricing Adjustments for Your Location

Card Swipe Locations

- Make Sure Your Game is Set to **Swipes Mode**:
 1. Hold the Test Button for 2 seconds to enter the Test Menu.
 2. Select “Pricing Adjustments” from the menu.
 3. Select “Currency Input” from the menu.
 4. Select “Card Swipes” from the menu.
 5. Exit out of “Currency Input” menu.
 6. While back in “Pricing Adjustments” menu, set “Swipe Value” to the currency equivalent of your swipe. **THIS SETTING IS EXTREMELY IMPORTANT!** (Example: If the card swipe is worth \$1.50 in your card system, set the swipe value to \$1.50 as well).

Coin and Token Locations

- Make Sure Your **Pricing & Coin Value** are Correct:
 1. Hold the Test Button for 2 seconds to enter the Test Menu.
 2. Select “Pricing Adjustments” from the menu.
 3. Select “Currency Input” from the menu.
 4. Select “Cash” or “Tokens” from the menu.
 5. Exit out of “Currency Input” menu.
 6. While back in “Pricing Adjustments” menu
 - a. Select “Coins to Play” and set the desired amount of coins per game.
 - b. After setting the coins per play, set “Coin Value” to the currency equivalent of your coin. **THIS SETTING IS EXTREMELY IMPORTANT!** (Example: If your coin is worth \$0.25, set “Coin Value” to \$0.25 as well).

Super Bikes™ 3

PC Hardware

Your Super Bikes uses a HP Elitedesk 705 G3 MT computer with a GeForce GTX 1050 graphics card. Listed below are the recommended BIOS settings for the computer.

NOTE 1

WARNING: DO NOT ENTER THE BIOS SETTINGS MENU! Modifying the BIOS settings will cause your game to stop functioning. In order to boot, new security features verify the BIOS settings against factory settings, including timestamp.

NOTE 2

In the event your video card needs to be replaced, any brand of GeForce GTX 1050 will work.



(HP Elitedesk 705 G3 MT)

Super Bikes™ 3

PC Hard Drive Recovery

Symptoms requiring a PC hard drive recovery include:

- File test reports bad or missing files.
- Game fails to finish loading during setup.
- After resetting the AC power, an error is reported.
- Erratic Game or Attract Mode behavior.

The only way to repair corrupt files is to reinstall the software as described below:

Computer

The computer contains sensitive components. Do not handle roughly. Call your distributor before servicing its internal components. Ask about warranty information as it relates to the PC.

Do **not** use the PC on/off switch. Turn AC power on or off with the cabinet power switch.

Steps to Re-Install the software:

(NO DVD Restoration. USB Thumb Drive is used on the *HP Elitedesk 705 G3 MT*)

1. With game and PC on, verify that the RIO board has power. If not, see Troubleshooting.
2. Open the coin door.
3. Insert the recovery USB thumb drive (included in your game) into the USB port on the Test button bracket inside the coin door.
4. Open lower back door of cabinet and plug in USB keyboard to PC.
5. Turn cabinet power switch to OFF. Wait 30 seconds.
6. Turn cabinet power switch to ON, and **HOLD** F9 on the keyboard until the Boot Menu screen appears.
7. Use the Up and Down arrow keys to highlight “Legacy – JetFlash Mass Storage Device” and press enter.
8. Follow on screen instructions to begin recovery.
9. If recovery does not begin, check to ensure USB Drive is inserted correctly and is not damaged.
10. Initial software loading may take several minutes. Check progress periodically.
Do not interrupt power or reset the game during recovery.
11. When software has been loaded, a message indicates that restore is complete. When instructed to remove USB Drive, wait 15 seconds to remove the drive from the PC.
12. Turn cabinet power switch off and then turn the cabinet on again. Your game will now be restored.

Super Bikes™ 3

Troubleshooting

Warning: Review the Safety section before making any adjustments to the game.

Problem	Possible Cause	Solution
Game will not power up.	Game not plugged in.	Plug game into AC outlet.
	Game not turned on.	Turn on main power switch.
	Game fuse is blown.	Check and replace fuse. See Specification section for fuse values.
	No power to receptacle.	Test AC outlet and plug game into powered outlet.
	PC BIOS set incorrectly.	See BIOS Settings section.
	Flash Drive Installer is left connected to PC.	Disconnect Flash Drive Installer and power cycle the game.
Buttons/Gas do not work.	Faulty micro switch.	Replace the micro switch on the joystick/button and re-test. Verify that the wires are connected to the correct spades on the micro switch.
	Faulty wiring.	Disconnect the cabinet from AC power. Verify that all wires are firmly connected to each joystick/button and the PCB. Verify that no wires are frayed or improperly shorting to ground. Verify that wires are connected to the correct spades on the micro switches.
	Faulty PCB.	Ensure all connections to PCB are secure. Replace PCB if faulty.

Super Bikes™ 3

Problem	Possible Cause	Solution
Neither buttons nor audio work.	PCB connected to faulty USB port (boot message may indicate not detected)	To test a USB port, turn off the game, disconnect the device from the port, and then connect the game dongle to the port. Reboot the game. A No Dongle message indicates the port is bad. If the game starts, the port is working. After the test, reconnect all devices to the correct USB ports and reboot.
No sound or bad sound.		Check connection to speakers.
	Bad connection.	Verify 1/8" audio cable is fully inserted in both the PC and the audio amplifier.
	Volume set too low.	Use VOL UP button on Test panel to raise volume
	Faulty wiring.	Verify all wires are firmly connected to the speakers, PCB, and green computer audio port. Verify that each wire is connected to the correct port and no wires are frayed or improperly shorting to ground.
	Blown speakers.	Remove the grill and inspect each speaker for visible damage. Run the Sound Test from System Tests in the Operator Menu to verify each speaker is working.
	Reversed wires.	A weak or low muffled sound is a sign of reversed speaker wires. Check for reversed wires on each speaker.
	Faulty PCB.	To verify audio is working at the computer, connect stereo headphones to the green computer audio port.

Super Bikes™ 3

Problem	Possible Cause	Solution
Constant low audio hum.	Faulty power supply.	Check external DC supply and the PC supply.
	Open ground.	Check all ground wires in cabinet. Ensure AC wall outlet is properly grounded
Game does not load.	PC hard drive failure.	Recover hard drive. See Flash Installer Document or contact your distributor for the latest software revision.
PC Drive test reports “bad” or “missing” files.		
Game fails to finish loading.		
After resetting, game still reports an error.		
Erratic game mode or attract mode.		
WARNING! Data files Corrupted. (Game Operation May Become Unstable.) Use “Test” Switch to Enter Test Mode and Run “File Test.”		
Game Resets	Bad file.	Run Flash Installer.
No Video	PC not turned on.	Turn PC power switch on. Ensure IEC cable tightly plugged in. Trace cable back to source to ensure continuity.
	Video cable not secure.	Check and secure DVI or HDMI connector to Monitor. Check and secure DVI or HDMI connector to PC.
Coin meter does not click during test.	No pulse to meter.	Check wiring from meter to PCB board.
	Faulty meter.	Replace coin meter.
	Blown fuse(s)	Replace 12VDC fuse(s) in cabinet.

Super Bikes™ 3

Problem	Possible Cause	Solution
Dongle Not Present	Dongle missing or disconnected.	Find dongle cable and reseal in USB port.
	Faulty USB port.	Insert dongle cable in different USB port.
Improper number of credits given when coins or bills are inserted.	Incorrect setting in Pricing Adjustments.	Adjust pricing settings.
	Faulty wiring.	Disconnect cabinet from AC power. Verify wires are firmly connected to coin mech and bill validator and ground wires are properly connected. Verify no wires are frayed or shorting to ground.
	Faulty coin mech.	Verify coin mech is not jammed. Ensure coin mech is properly aligned and latched to coin door.
Exits Test Mode every 3 seconds.	Test button stuck in ON position.	Slide or toggle button off after Test Menu appears
Connect RIO Board or RIO Board Missing or RIO Disconnected.	USB cable disconnected.	Check USB connection from PC to RIO board.
	No Power to RIO board.	Check for proper voltage (+5V, +12V) at RIO P1 connector.
File Error.	The game attempted to do a System Call but it failed (memory/file handle issue).	Reboot the cabinet.
Ticket Error. See Attendant. Tickets Owed.	The cabinet has run out of tickets. The number of tickets owed should be displayed.	Add tickets to empty dispenser(s).
Machine ID Conflict Error.	Networking is Enabled, but two or more of the connected cabinets are using the same Machine ID.	Go to "System Settings>Network Settings>Network Machine ID." All connected cabinets MUST be using a different "Network Machine ID."
Game keeps rebooting without starting.	Software was downgraded to a previous version.	Update game with a USB drive to latest version.

Super Bikes™ 3

Technical Support

For an authorized distributor near you, check the Raw Thrills website at www.rawthrills.com

Betson's Raw Thrills Technical Support Hotline

Phone: 1-800-753-2513

FAX: 1-201-438-5019

Email: rtsupport@betson.com



Super Bikes™ 3

Electrical and Mechanical Illustrations

SUPERBIKES 3

Assembled Dimensions
98.25" H x 45.19" W x 84.625" D
Approx Weight 660 lbs

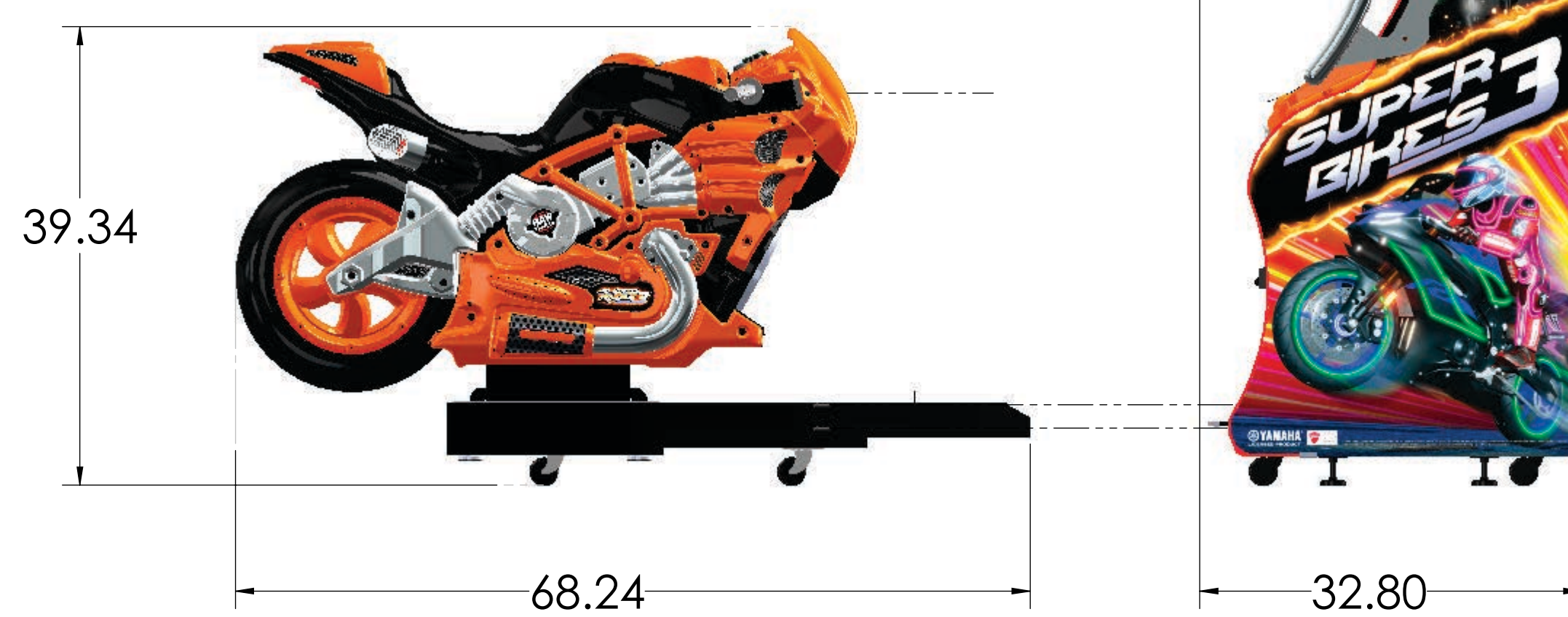
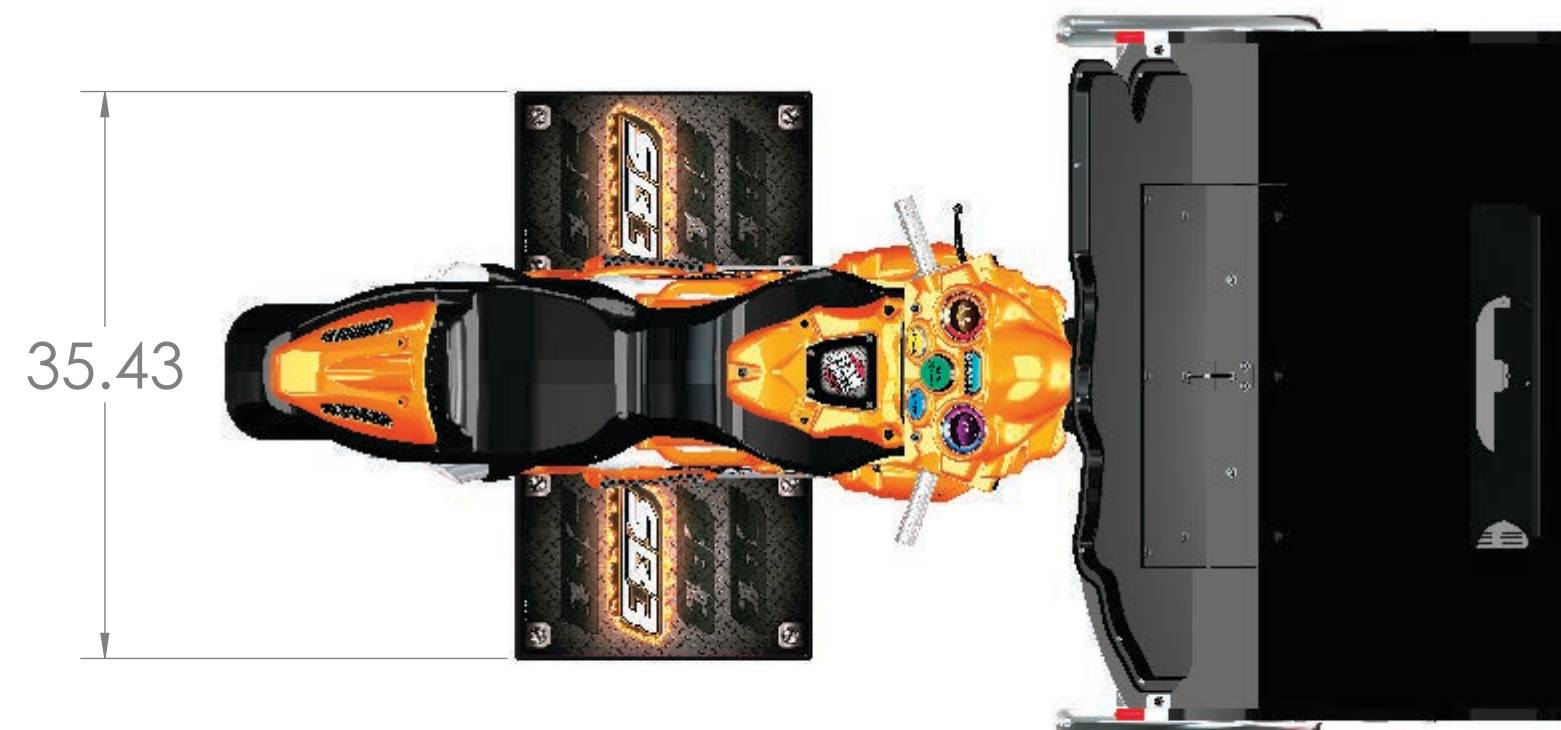

PROPRIETARY AND CONFIDENTIAL
THE INFORMATION CONTAINED IN THIS DRAWING IS THE SOLE PROPERTY OF ©BSEBT COMPANY NAME HERE». ANY REPRODUCTION IN PART OR AS A WHOLE WITHOUT THE WRITTEN PERMISSION OF ©BSEBT COMPANY NAME HERE» IS PROHIBITED.

UNLESS OTHERWISE SPECIFIED:		NAME	DATE	RAW THRILLS, INC
DIMENSIONS ARE IN INCHES				
FRACTIONAL ±	DRAWN			SUPERBIKES 3
ANGULAR ± MATCH ± BEND ±	CHECKED			
TWO PLACE DECIMAL ±	ENG APPR.			SIZE DWG. NO.
THREE PLACE DECIMAL ±	MFG APPR.			D SB-3-Final Assy-PRODUCTION
	Q.A.			REV
INTERPRET GEOMETRIC TOLERANCING PER:	COMMENTS:			1
MATERIAL				SCALE: 1:32 WEIGHT:
FINISH				SHEET 1 OF 5
NEXT ASSY	USED ON			
APPLICATION	DO NOT SCALE DRAWING			

SUPERBIKES 3-SETUP

SUPERBIKES 3 MARQUEE HEADER DISPLAY

SUPERBIKES 3 MARQUEE HEADER DISPLAY-
SECURE MARQUEE HEADER TO MAIN CABINET WITH (3) 1/4-20 TORX HEAD SCREWS (INCLUDING LOCK AND FLAT WASHERS).

CONNECT WIRE HARNESS LOCATED ON TOP OF MAIN CABINET AFTER HEADER IS SECURED ON TOP OF MAIN CABINET.

SUPERBIKES 3 MAIN CABINET ASSEMBLY

INSTALLING BIKE TO MAIN CABINET ASSEMBLY-

FIRST, CONNECT INTERNAL WIRE HARNESS FROM INSIDE MAIN CABINET TO BIKE ASSEMBLY MANUALLY.

PUSH BIKE ASSEMBLY INTO RECTANGULAR OPENING AND SECURE THE BIKE ASSEMBLY WITH (4) 1/4-20 TORX HEAD SCREWS (INCLUDING LOCK AND FLAT WASHERS) FROM THE HARDWARE BAG INSIDE THE COIN BOX.

SUPERBIKES 3 BIKE ASSEMBLY

ALWAYS LOWER LEG LEVELERS TO FLOOR AFTER GAME(S) ARE LOCATED IN THEIR OPERATING POSITION.

SUPERBIKES 3 - MARQUEE HEADER DISPLAY

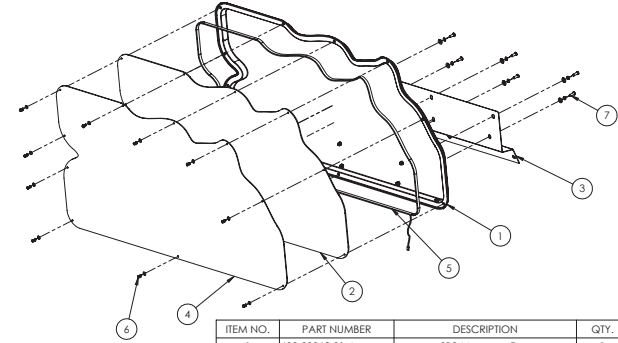

ITEM NO.	PART NUMBER	DESCRIPTION	QTY.
1	603-00962-01-Assy	SB3-Marquee Pan	1
2	606-01553-01	SB3-Header Graphic-1 (Orange)	1
3	600-02418-01	MARQUEE HEADER MOUNTING BRACKET	1
4	600-02406-01	SB3-Header Lens Clear PETG	1
5	500-00162-01-275	LED Strip - WHITE w/Foam Tape	1
6	#8-32 X1.2 W FLAT WASHER	#8-32 X1/2 W FLAT WASHER	10
7	TORX 1.4-20 X 3.4	TORX 1/4-20 X 3/4 W FLAT AND LOCK WASHER	6

MAINTAIN MIN 3"-6" OF CLEARANCE FROM REAR CABINET TO WALL FOR CABINET VENTING.

PROPRIETARY AND CONFIDENTIAL
ALL INFORMATION CONTAINED HEREIN IS THE SOLE PROPERTY OF BMI GAMING, INC. AND IS TO BE KEPT CONFIDENTIAL. ANY REPRODUCTION IN PART OR AS A WHOLE WITHOUT THE WRITTEN PERMISSION OF BMI GAMING, INC. IS PROHIBITED.

UNLESS OTHERWISE SPECIFIED: DIMENSIONS ARE IN INCHES TOLERANCES: FRACTIONS ANGULAR MATCH ± .010 DECIMALS ± .005 THREE PLACE DECIMAL ± .001	DRAWN: CHECKED: ENG APPR: MFG APPR: DATE: TOLERANCES: REVISIONS:	NAME: DATE:	RAW THRILLS, INC TITLE: SUPERBIKES SETUP&ASSEMBLY SIZE: DWG. NO. 18-3-Final Assy-PRODUCTION REV 1 SCALE: 1:12 WEIGHT: SHEET 1 OF 4
NEXT ASSY: APPLICATION:	USED ON: DO NOT SCALE DRAWING		

8 7 6 5 4 3 2 1

SUPERBIKES 3 BIKE LEFT SIDE VIEW

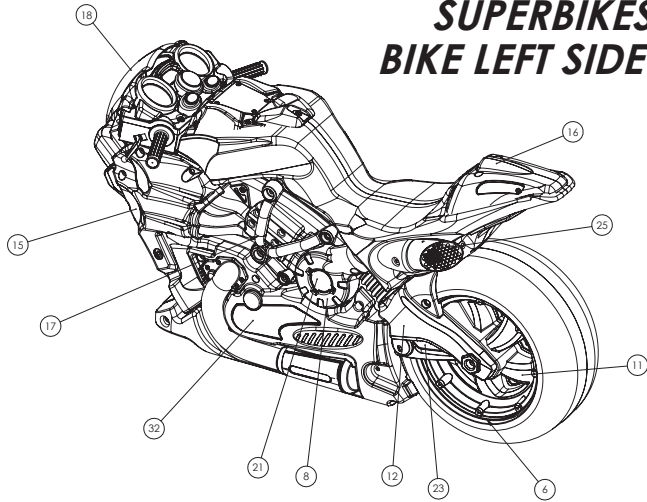

SUPERBIKES 3 BIKE SUBASSEMBLY VIEWS

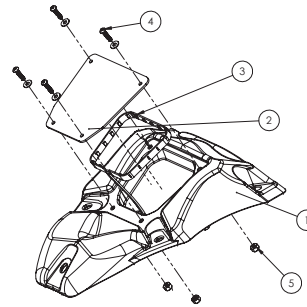

TANK COVER ASSEMBLY

ITEM NO.	PART NUMBER	DESCRIPTION	QTY.
1	603-00955-01	SB3-Tank Shroud	1
2	606-01618-01	SB3 TANK COVER GRAPHIC	1
3	500-00162-01-3D	WHITE LED WITH FOAM TAPE - 30CM	1
4	#8-32 X 3.4 W FLAT WASHER	#8-32 X 3.4 W FLAT WASHER	4
5	90631A009	90631A009 LOW-STRENGTH STEEL NYLON-INSERT LOCKNUT	4

SIDE VENT LED ASSEMBLY (2) REQUIRED FOR R & L

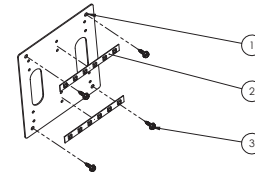

ITEM NO.	PART NUMBER	DESCRIPTION	QTY.
1	600-02401-01	SB3-LED Side Mounting Plate (2)	1
2	500-00162-01-10	10CM 4in LED Strip White (with foam tape)	2
3	90054A148	90054A148 HEX WASHER HEAD SCREW FOR SHEET METAL	4

ITEM NO.	PART NUMBER	DESCRIPTION	QTY.
1	603-00932-01	SB3-Bike body	1
2	SB-3-Handle Bar Assy-3		1
3	602-00001-00	Bike Bracket - Left	1
4	602-00002-00	Bike Bracket-Right	1
5	500-00205-01	White Super Puck Light	1
6	WHEEL-LED T-MOLDING-ASSY	WHEEL-ROB -LED T-MOLDING-ASSY	2
7	603-00875-01	SB3 R BIKE HEAD -IM (PLATED)	1
8	603-00876-01	SB3 L BIKE HEAD -IM (PLATED)	1
9	603-00881-01	SB3 Spoke Cover - R-IM (COLOR)	1
10	603-00877-01	SB3 R Arm-IM (Plated)	1
11	603-00882-01	SB3 Spoke Cover - L-IM (COLOR)	1
12	603-00878-01	SB3 Bike L Arm -IM (Plated)	1
13	603-00884-01	SB3 R Side Frame Section-IM (COLOR)	1
14	603-00873-01	SB3 R Side Upper Vent-IM (COLOR)	1
15	603-00874-01	SB3 Bike L Side Upper Vent-IM (MULTI-COLOR)	1
16	603-00879-01	SB3 Tail -IM (COLOR)	1
17	603-00885-01	SB3 L Side Frame Section-IM (COLOR)	1
18	603-00872-01	SB-3 Windshield	1
19	606-01476-01	SB3-Engine RThrills Emblem-R	1
20	606-01484-01	SB3-Low Faring Decal PIPE-L	1
21	606-01477-01	SB3-Engine RThrills Emblem-L	1
22	606-01478-01	SB3-Arm decal R	1
23	606-01479-01	SB3-Arm decal L	1
24	SB3 Tailight-Assy	SUPERBIKES 3 Tailight-Assy	1
25	SB3 TAILPIPE_ASSY	SUPERBIKES 3 TAILPIPE_ASSY	2
26	SB3-8inWoofer-Assy	SUPERBIKES 3-8inWoofer-Assy	1
27	TORX 1-0	TORX VARIOUS LENGTH, LOCK AND FLAT WASHER	33
28	Vent LED Assy	SUPERBIKES 3 SIDE Vent LED Assy	2
29	Fender LED Assy		1
30	SB3 Tank Cover Assy	SB3 Tank Cover Assy	1
31	603-00886-01-Assy	Right Lower Faring Assembly	1
32	603-00887-01-Assy		1

SUPERBIKES 3 BIKE RIGHT SIDE EXPLODED VIEW

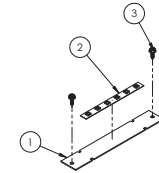
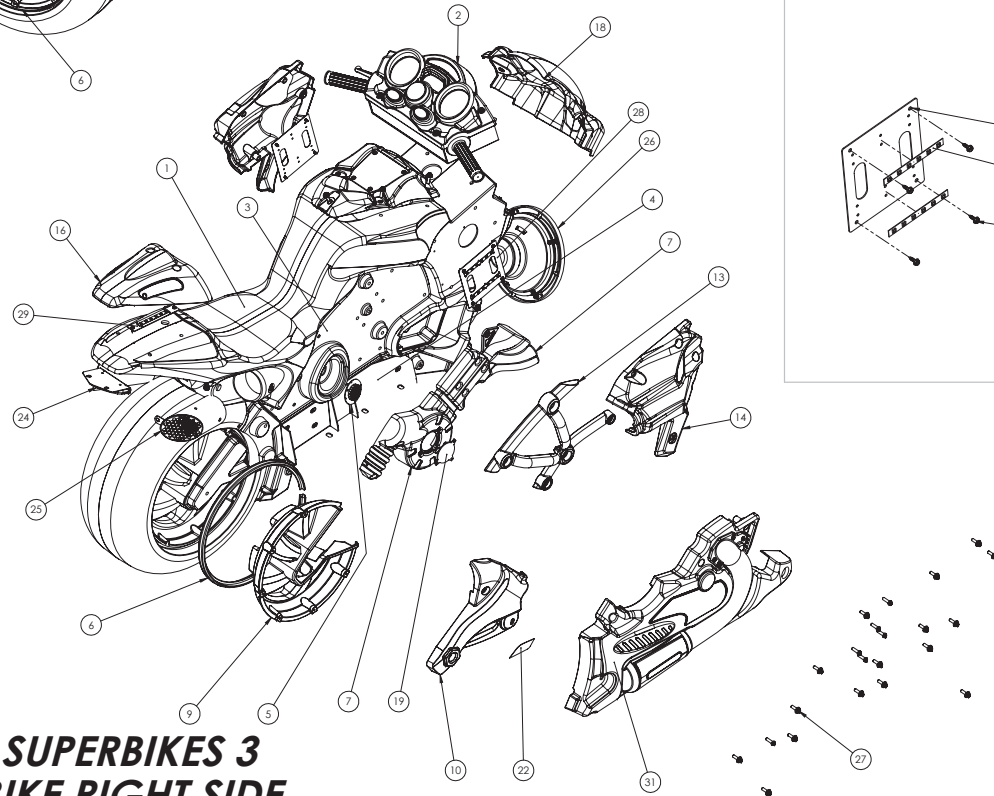

FENDER LED ASSEMBLY

ITEM NO.	PART NUMBER	DESCRIPTION	QTY.
1	600-02402-01	SB3-LED Fender Mounting Plate	1
2	500-00162-01-10	10CM 4in LED Strip White (with foam tape)	1
3	90054A148	90054A148 HEX WASHER HEAD SCREW FOR SHEET METAL	2

UNLESS OTHERWISE SPECIFIED:		DATE	RAW THRILLS, INC
DIMENSIONS ARE IN INCHES	TOLERANCES	DRAWN	TITLE:
FRACTIONS & ANGULAR MATCH	FINISH	CHECKED	
THREE PLACE DECIMAL	THREE PLACE DECIMAL	ENG APPR.	
		MFG APPR.	
		QA	
		TECHNICAL	
<small>PROPRIETARY AND CONFIDENTIAL THE INFORMATION CONTAINED IN THIS DRAWING IS THE SOLE PROPERTY OF RAW THRILLS, INC. IT IS TO BE USED FOR THE MANUFACTURE OF THE PART OR ASSEMBLY HEREIN. IT IS NOT TO BE REPRODUCED, COPIED, OR TRANSMITTED IN ANY FORM OR BY ANY MEANS, ELECTRONIC OR MECHANICAL, INCLUDING PHOTOCOPYING, RECORDING, OR BY ANY INFORMATION STORAGE AND RETRIEVAL SYSTEM, WITHOUT THE WRITTEN PERMISSION OF RAW THRILLS, INC.</small>		NEXT ASSY USED ON APPLICATION	REV 1 SB-3-Final Assy-PRODUCTION SCALE: 1:12 WEIGHT: SHEET 2 OF 4

8 7 6 5 4 3 2 1

SUPERBIKES 3 BIKE SUBASSEMBLY VIEWS

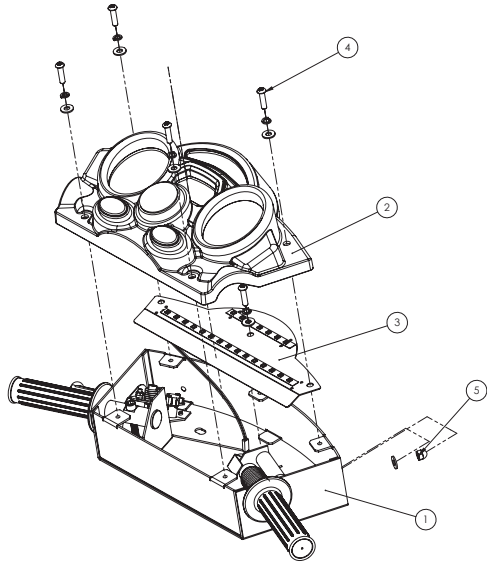

ITEM NO.	PART NUMBER	DESCRIPTION	QTY.
1	604-00056-01-Assy	50-0568-10	1
2	SB-3-Handle Bar Bezel Assy	Superbikes-3-Handle Bar Bezel Assy	1
3	SB3-CP-LED Bracket Assy	Superbikes 3-Control Panel-LED Bracket Assy	1
4	1-4 FLAT WASHER		2
5	9B667A210	1-4-20Acorn Nut-SHORT	2
6	TORX 1 1.4-20	TORX 1", LOCK AND FLAT WASHER	5

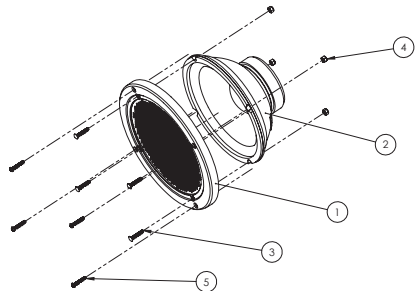

ITEM NO.	PART NUMBER	DESCRIPTION	QTY.
1	600-02404-01-	8 inch Woofer Ring	1
2	2-1-18-00-00-000	8" Woofer, 4 Ohm, Poly-Mica Cone	1
3	92356A261	#8x1_CARRIAGE BOLT	4
4	90631A009	90631A009 LOW-STRENGTH STEEL NYLON-INSERT LOCKNUT	4
5	96075A147	#8-32x1in Tamper Torx	4

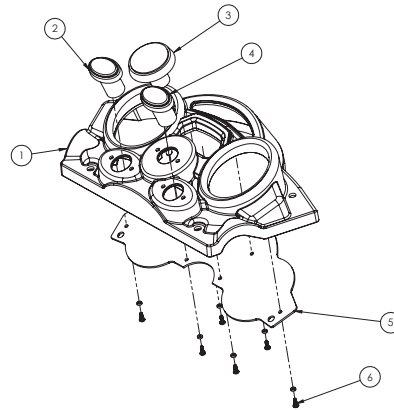

ITEM NO.	PART NUMBER	DESCRIPTION	QTY.
1	603-00880-01	SB3-Bar Cover	1
2	702-00099-01	SB-3/Small Oval Orange Button-"Tunes" legend, 6V LED, CK GD .187	1
3	702-00097-01	SB-3/Large Green Round Button-"Start/Nitro" legend, 6V LED, CK GD .187	1
4	702-00098-01	SB-3/Small Oval Blue Button-"View" legend, 6V LED, CK GD .187	1
5	606-01475-01	SB3-Handlebar PETG Translight	1
6	#6x3 8 SCREW & WASHER	#6x3 8 THREAD-CUTTING SCREW&NEOPRENE WASHER	6

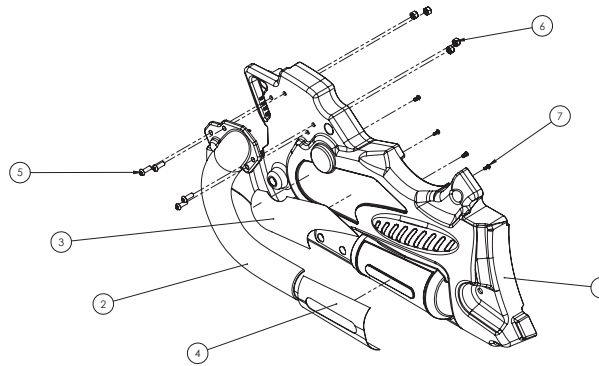

ITEM NO.	PART NUMBER	DESCRIPTION	QTY.
1	603-00887-01	SB3 Bike L Side Lower Fairing-IM (COLOR)	1
2	603-00889-01	SB3 L Side Lower Pipe-IM (PLATED)	1
3	606-01482-01	SB3-Low Fairing Decal L	1
4	606-01484-01	SB3-Low Fairing Decal PIPE-L	1
5	TORX1-4-20_3_4 in	TAMPER RESIST 1/4-20 X 3/4 INCH L	4
6	90640A129	90640A129 LOW-STRENGTH STEEL NYLON-INSERT LOCKNUT	4
7	94629A670	94629A670 THREAD-CUTTING SCREW FOR SOFT PLASTICS (I)	4

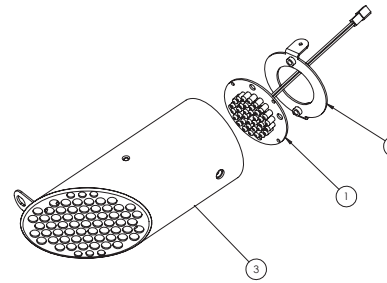

ITEM NO.	PART NUMBER	DESCRIPTION	QTY.
1	500-00204-01	RED SUPERPUCK LED LIGHT	1
2	608-00198-02	SB3 SUPERPUCK MOUNT BRACKET	1
3	608-00232-01	SB3 TAILPIPE - CHROME	1

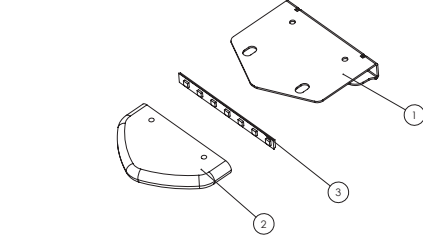

ITEM NO.	PART NUMBER	DESCRIPTION	QTY.
1	600-01451-01	M-GP/SB3 TAIL LIGHT BRACKET	1
2	600-02265-01	SB3-Tail Light Acrylic	1
3	500-00184-13	RGB LED with Foam Tape 10CM	1

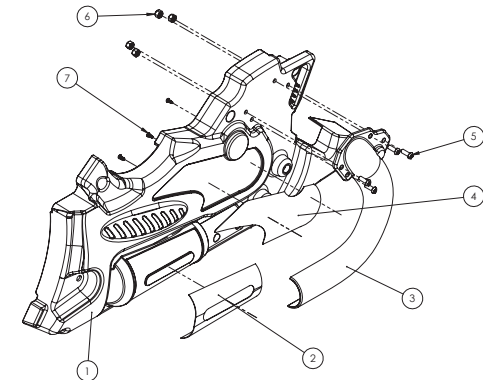

ITEM NO.	PART NUMBER	DESCRIPTION	QTY.
1	603-00886-01	SB3 Bike R Side Lower Fairing-IM (COLOR)	1
2	606-01483-01	SB3-Low Fairing Decal PIPE-R	1
3	603-00888-01	SB3 R Side Lower Pipe-IM (PLATED)	1
4	606-01481-01	SB3-Low Fairing Decal R	1
5	TORX1-4-20_3_4 in	TAMPER RESIST 1/4-20 X 3/4 INCH L	4
6	90640A129	90640A129 LOW-STRENGTH STEEL NYLON-INSERT LOCKNUT	4
7	94629A670	94629A670 THREAD-CUTTING SCREW FOR SOFT PLASTICS (I)	4

UNLESS OTHERWISE SPECIFIED:	NAME	DATE	RAW THRILLS, INC TITLE: BIKE SUB-ASSEMBLIES SIZE: DWG. NO. D SB-3-FINL Assy-PRODUCTION REV 1 SCALE: 1:12 WEIGHT: SHEET 3 OF 4
DIMENSIONS ARE IN INCHES	DRAWN		
TOLERANCES	CHECKED		
ANGULAR MATCH: BND ±	ENG APPR		
FIT: PLACE DECIMAL ±	MFG APPR		
THREE PLACE DECIMAL ±	QA		
THREE DECIMIC TOLERANCE/FIT	TECHNOLOG		
MAXIMUM			
NEST ASST	USED ON	INSTR	
APPLICATION	DO NOT SCALE DRAWING		

ITEM NO.	PART NUMBER	DESCRIPTION	QTY.
1	603-00920-01	SB3 IM SPEAKER MOUNT-RGHT	1
2	2-1-10-00-00-000	Speaker, 5-1/4, 8 ohm, full range	1
3	#8-32 X 3.4 W FLAT WASHER	#8-32 X 3.4 W FLAT WASHER	4
4	90631A009	90631A009_LOW-STRENGTH STEEL NYLON-INSERT LOCKNUT	4

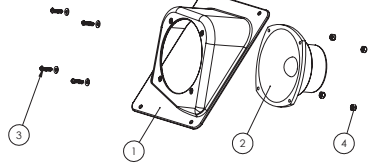

RIGHT SPEAKER ASSEMBLY-CABINET
(RIGHT AND LEFT REQUIRED- FOR LEFT SIDE USE SPEAKER MOUNT LEFT / 603-00921-01)

ITEM NO.	PART NUMBER	DESCRIPTION	QTY.
1	603-00867-01	SB3 Speaker Housing-RM (BLACK)	1
2	2-1-10-00-00-000	Speaker, 5-1/4, 8 ohm, full range	1
3	603-00890-01	SB3 Speaker Cover-IM (Plated)	1
4	90925A199	TORX DRIVE SCREW FOR SHEET METAL	4
5	600-02154-01	SB3- Speaker Grill	1
6	500-00184-01-56	RGB with Foam Tape-56 cm Speakers	1
7	90935A194	90935A194 PAN HEAD PHILLIPS SCREW FOR SHEET METAL	8

SPEAKER ASSEMBLY-MINI
(2 REQUIRED)

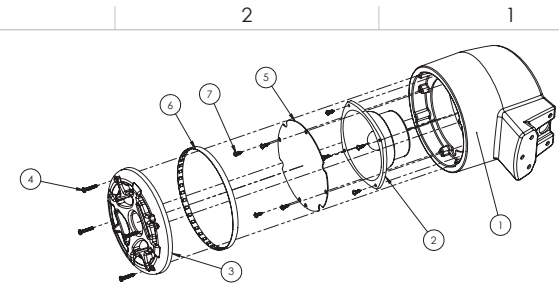

ITEM NO.	PART NUMBER	DESCRIPTION	QTY.
1	601-00818-01	SB-3 Main Cabinet	1
2	800-00005-01		1
3	Superbikes 3_A-C Plate Assy	Superbikes 3_A-C Plate Assy	1
4	FanAssy	12VDC Fan and Wire Grill Assy	3
5	850-00025-01	HP 705 G3 MT (310-00001-GTX 1050 Video Card)	1
6	PC-Strap Assy	PC-Strap Assy	2
7	42-SB3_Monitor_Assy	42"-Moto-GP_Monitor_Assembly	1
8	SUPERBIKES 3_Silther-RIO2_Assy	RIO2 Assembly w/ Mounting Plate	1
9	603-00869-01	Head Right-IM	1
10	603-00870-01	Head Left-IM	1
11	603-00871-01	Center Intake-IM	1
12	600-00500-01	SB2-Inner Tunnel Support	1
13	601-00819-01	SB-3 Main Cabinet-Upper Back Door Panel	1
14	601-00820-01	SB-3 Main Cabinet-Lower Back Door Panel	1
15	600-02151-01	SB3-LED Marquee Bracket - Inner	1
16	SB-3 Blower Assembly	SEE DETAILS	1
17	500-00162-96	104cm LED Strip White	3
18	600-02150-01	SB3-Front Kick Plate Bracket (2 req'd)	2
19	606-01494-01-C	SB3- REAR Marquee PETG .125	1
20	600-02157-01	SB3- REAR Marquee PETG .125	1
21	600-02268-01	SB3-Rear Access Plate	1
22	Camera LED Assy	SEE DETAILS	1
23	600-02177-01	SB3- LED T-Molding Clip	4
24	LED-Tmold	INSTALL 260CM RGB LED	2
25	Speaker-Assy-Mini	SEE DETAILS	2
26	IM-Speaker-Assy-L	SEE DETAILS	1
27	IM-Speaker-Assy-R	SEE DETAILS	1
28	600-02152-01	Marquee-Lower Bracket	1
29	SB3-Marquee-Assy-REV2	SB3-Marquee-Assy-REV2	1
30	500-00162-	20CM LED Strip White (with foam tape)	6
31	500-00184-13	RGB LED with Foam Tape 10CM	1
32	SideArchAssy	SB3 - SIDE ARCH (CHROME PLATED-STEEL)	2
33	Upper Chrome T-Mold	Upper Chrome T-Mold	1
34	Nose-Chrome T-Mold	Nose-Chrome T-Mold	1
35	600-02178-01	SB3 CABINET SPEAKER GRILL (2 REQ'D)	2
36	600-02395-01	SB3 CABINET SPEAKER FRAME (2 REQ'D)	2
37	600-02394-01	SB3- Blower Frame	1
38	600-02155-01	SB3- Blower Grill	1
39	24 PIN MINI-FIT_W-CABLE	039012246	1
40	18 PIN MINI-FIT_W-CABLE	039012181	1
41	500-00193-01	RSP-320-12; 320W, 12V PFC Dual Voltage Power Supply	1
42	330-00004-01	LRS-150F-12; 1500W, 12V Dual Voltage Power Supply	1
43	01-1842	Moto-GP Header Harness Plate w Grommet	1
44	Fuseblock x 10	Fuseblock x 10	1
45	442-00001-01	Power Line Filter (Corcom 6MY1)	1
46	800-00040-01	6210AXXSZS-DC3 / 6210DSX-1: Solid State Relay	1
47	601-00580-01	PC Wood Cleat	2

SUPERBIKES 3 - MAIN CABINET ASSEMBLY

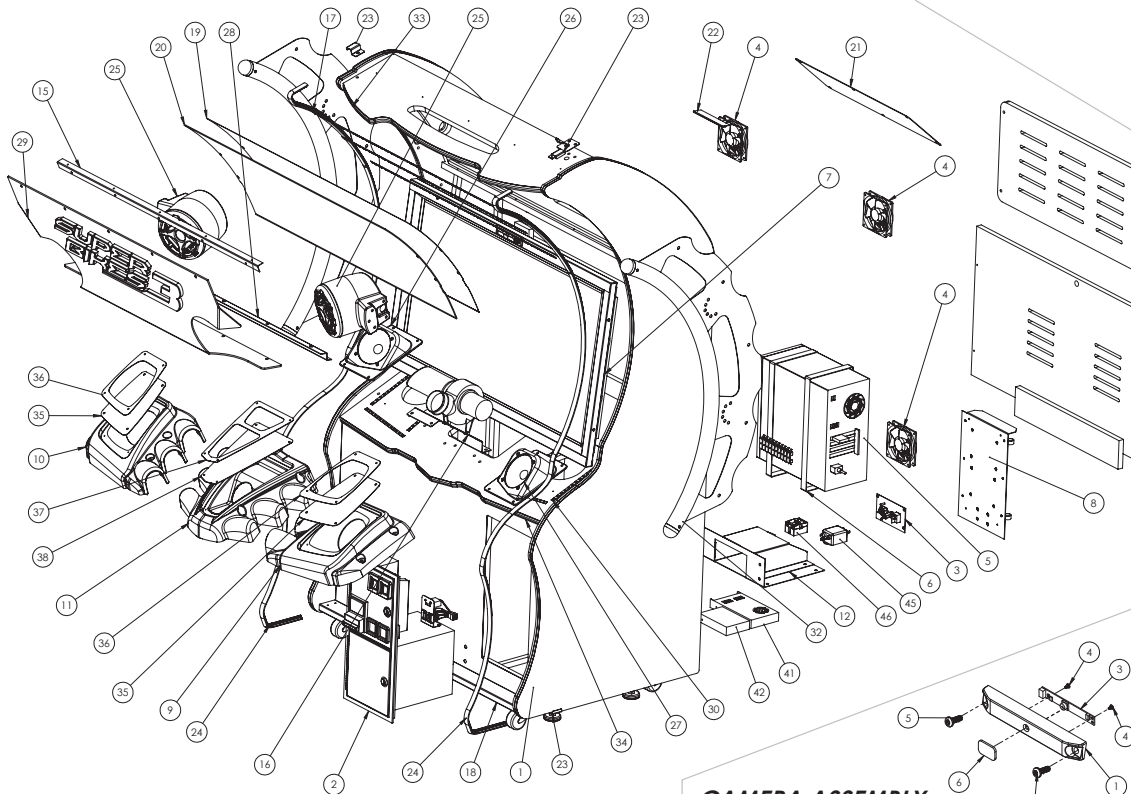

MARQUEE ASSEMBLY

ITEM NO.	PART NUMBER	DESCRIPTION	QTY.
1	600-02159-01	SB3- Front Marquee PETG .25	1
2	603-00891-01	SUPER BIKE 3 LOGO	1
3	94629A670	THREAD-CUTTING SCREW FOR SOFT PLASTICS (1)	28

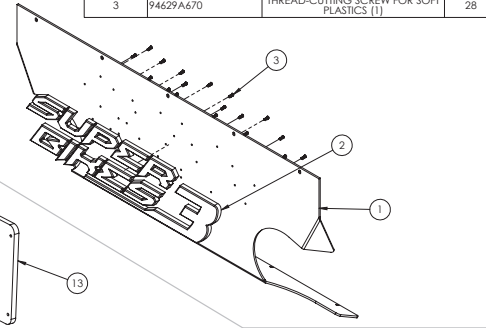

LCD ASSEMBLY

ITEM NO.	PART NUMBER	DESCRIPTION	QTY.
1	600-00073-01	42" Tempered Glass Panel	1
2	125blackfoamtape-small	1/8" X 3/8" W X 2'L Black Foam Tape Section	2
3	809-00004-01	42" LCD Monitor / MT42W-267A	1
4	608-00156-02	Monitor_Frame_Assy Weldement	1
5	Camera-Housing-Assy	Moto-GP Camera Assembly	1
6	LCD Foam Tape	1/16" X 3/4" W X 120" Total Length-Black Foam Tape	1
7	600-02176-01	SB3-Camera Acrylic Block	1

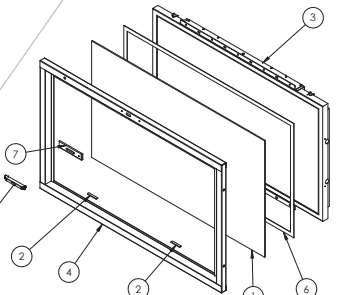

CAMERA ASSEMBLY

ITEM NO.	PART NUMBER	DESCRIPTION	QTY.
1	603-00764-01	Camera-Housing/Moto-GP	1
2	500-00249-01	SB-3 Webcam (OR USE 500-00185-01)	1
3	500-00185-01	Moto-GP Webcam	1
4	99461A605	Pan Head Phillips 1-32x1/8"	2
5	93701A408	8-32-1.2 TORX TAMPER-BLK	2
6	600-01790-01	Camera Lens Cover-Plastic	1

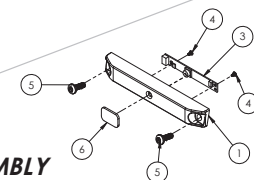

PROPRIETARY AND CONFIDENTIAL
THIS INFORMATION CONTAINED HEREIN IS THE SOLE PROPERTY OF BMI GAMING. IT IS TO BE USED ONLY FOR THE PURPOSES SPECIFIED IN THIS DRAWING. IT IS NOT TO BE REPRODUCED, COPIED, OR DISCLOSED TO ANY OTHER PARTY WITHOUT THE WRITTEN PERMISSION OF BMI GAMING.

UNLESS OTHERWISE SPECIFIED:
DIMENSIONS ARE IN INCHES
TOLERANCES:
FRACTIONS DECIMALS
HOLE PLACES OTHER PLACES
HOLE DIA. TOLERANCE
FINISH:
TEXT: UNLESS OTHERWISE SPECIFIED, DIMENSIONS ARE IN INCHES
DRAWN: []
CHECKED: []
ENG APPR: []
MFG APPR: []
DATE: []
SCALE: 1:1
SHEET 4 OF 4

RAW THRILLS, INC
TITLE: **SUPERBIKES 3 MAIN CABINET**
SITE: [] DWG. NO.: **D** 18-3-Final Assy-Production REV 1
SCALE: 1:132 WEIGHT: [] SHEET 4 OF 4

SUPERBIKES 3 DIE LINE USE



LEFT SIDE VIEW
-IMAGES SHOWN SUBJECT TO CHANGE-

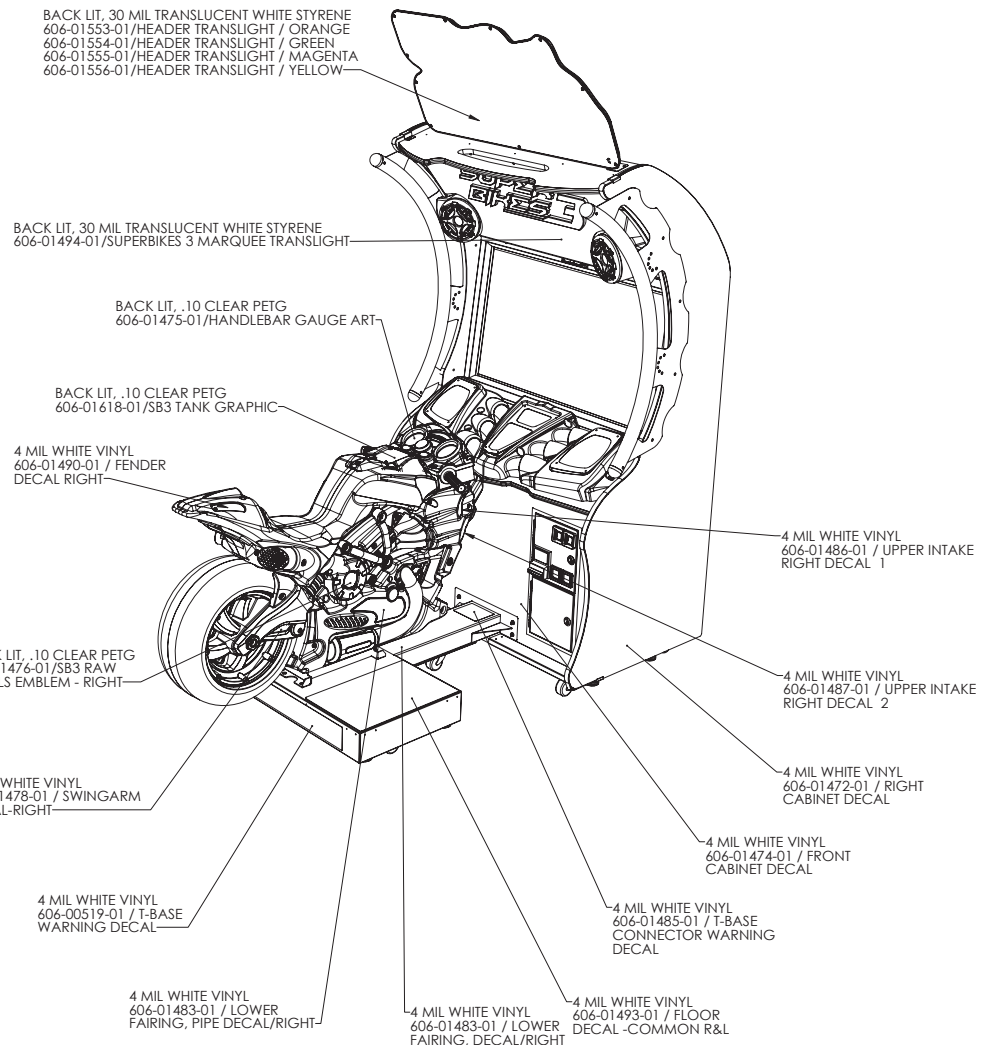

RIGHT SIDE VIEW

LOWER MAIN

LOWER MAIN HARNESS: [CA-4768]

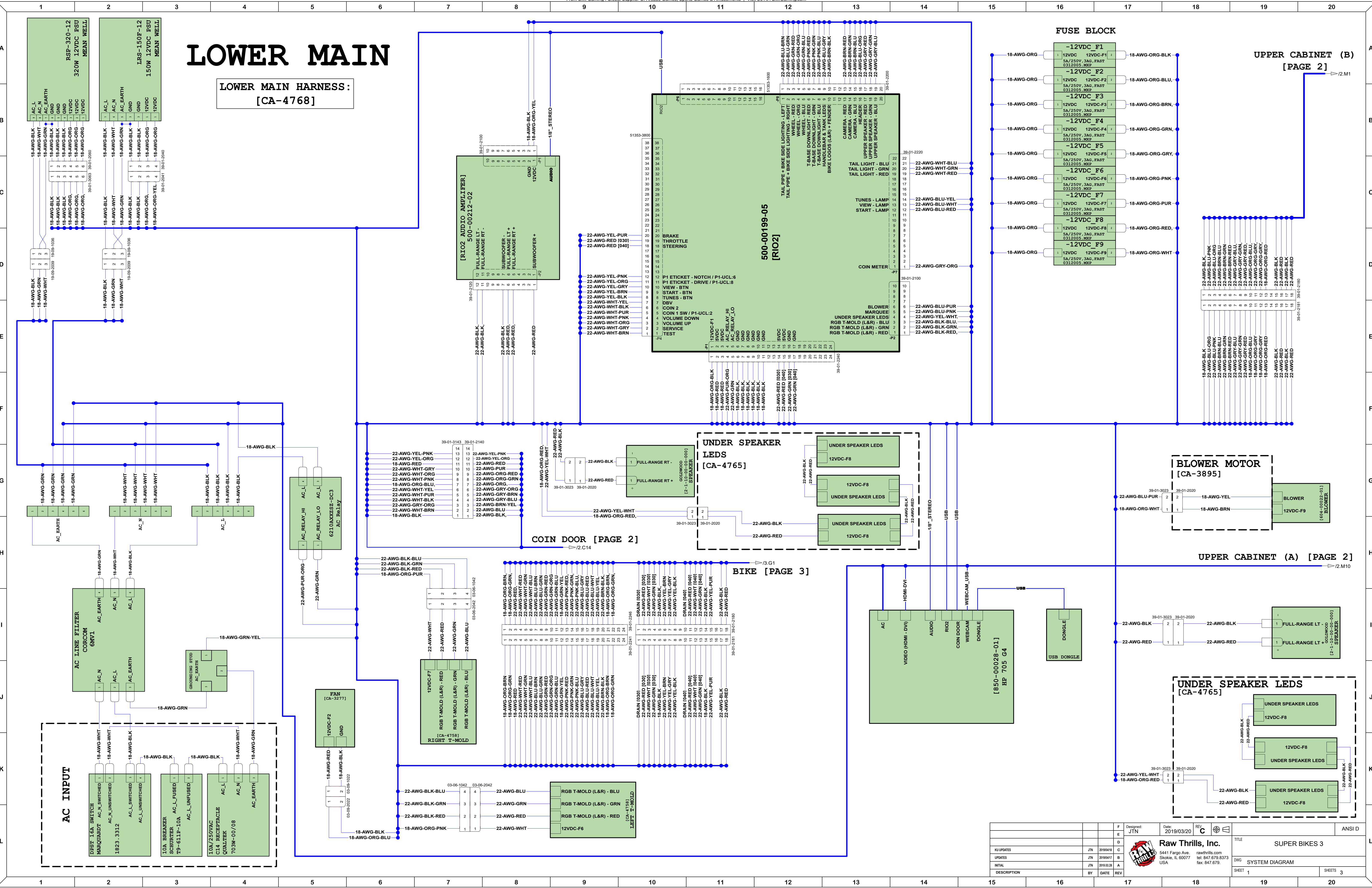

FUSE BLOCK

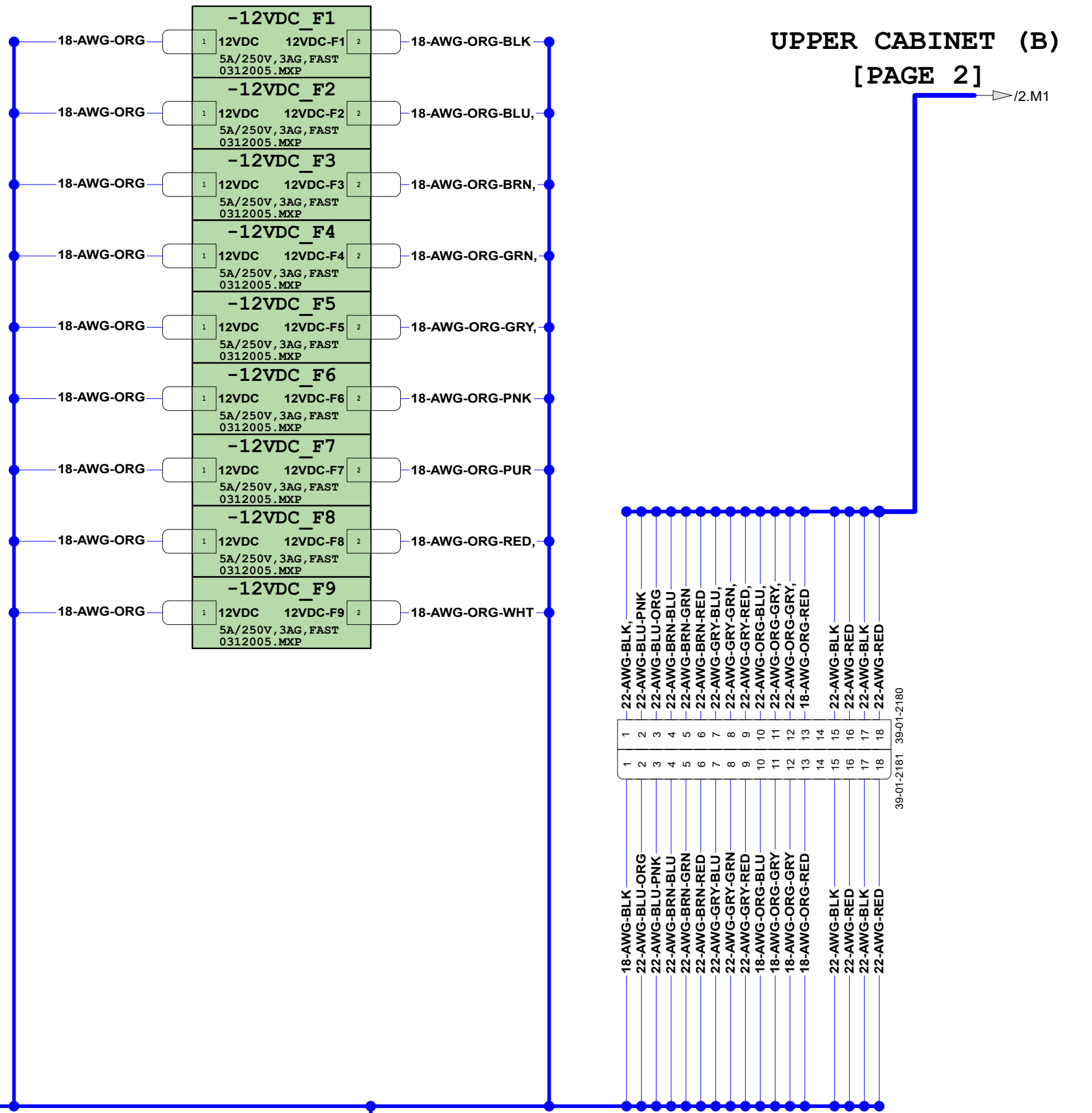

UPPER CABINET (B) [PAGE 2]

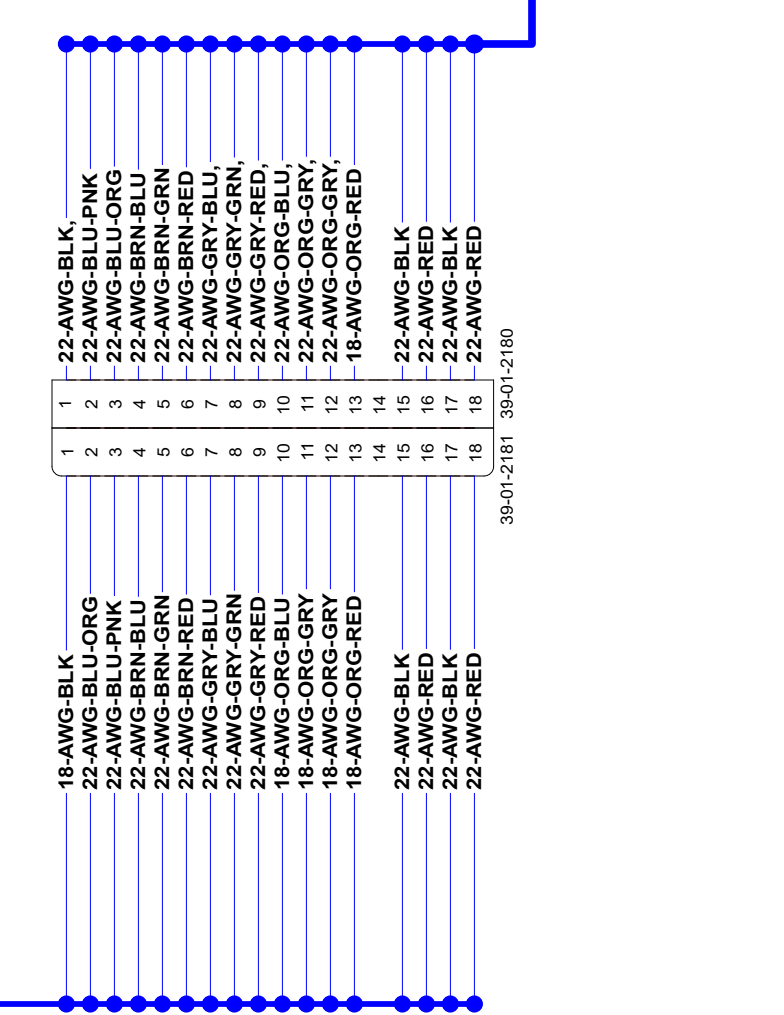

BLOWER MOTOR [CA-3895]

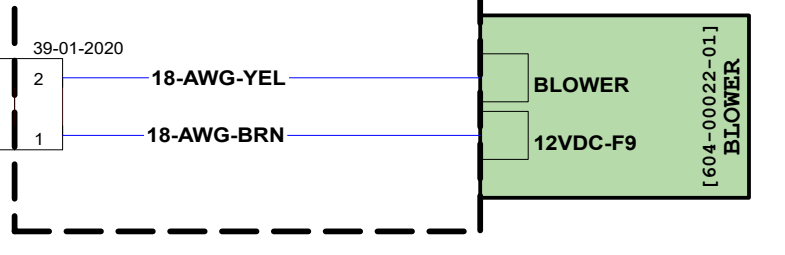

UPPER CABINET (A) [PAGE 2]

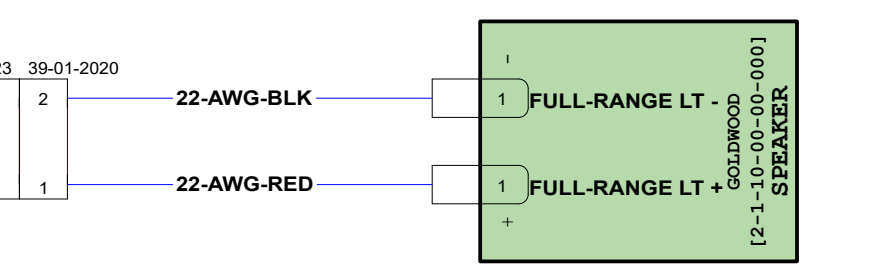

UNDER SPEAKER LEADS [CA-4765]

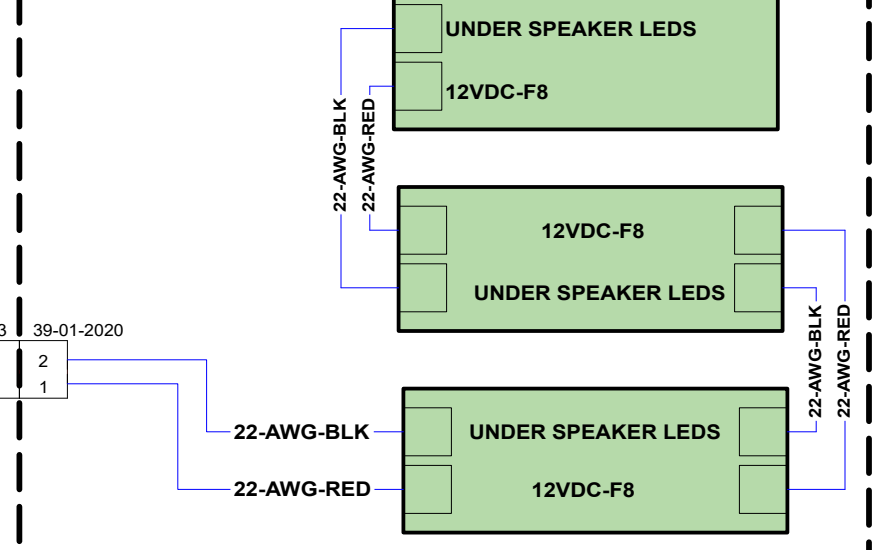

UNDER SPEAKER LEADS [CA-4765]

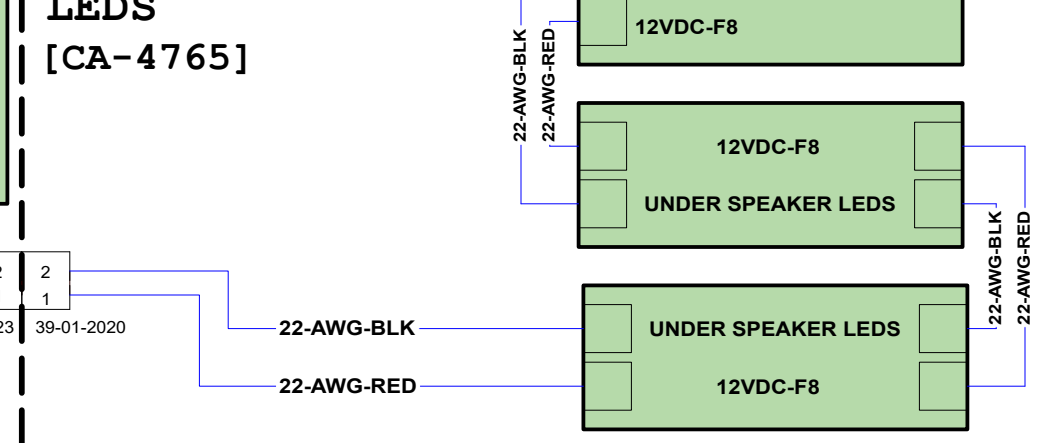

BIKE [PAGE 3]

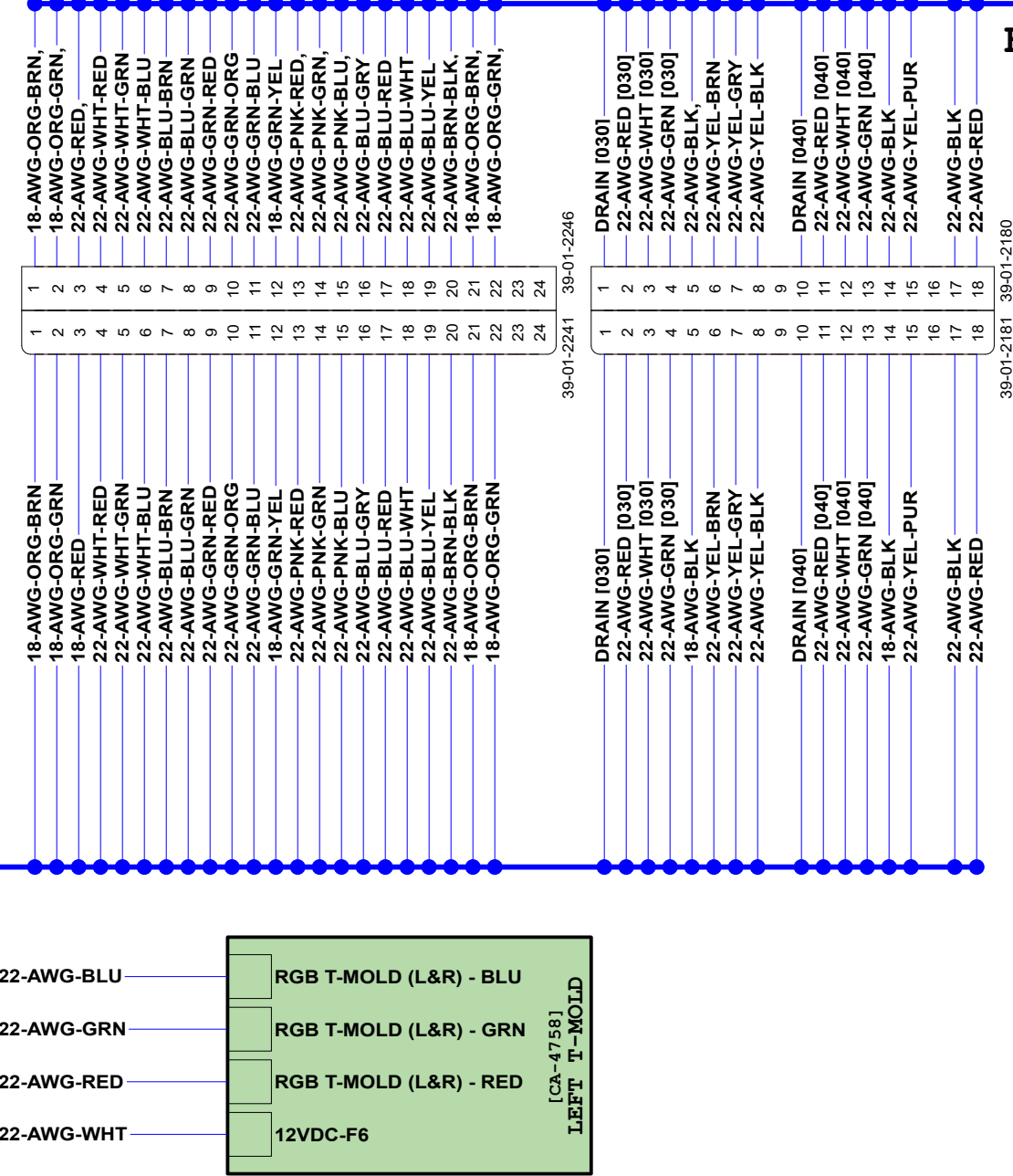

COIN DOOR [PAGE 2]

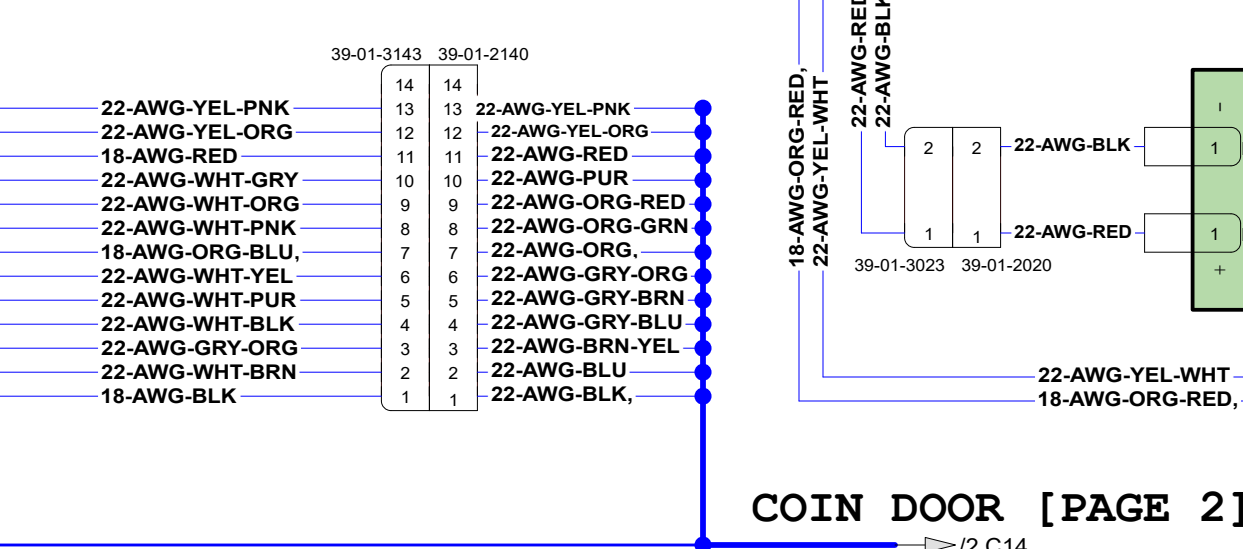

AC INPUT

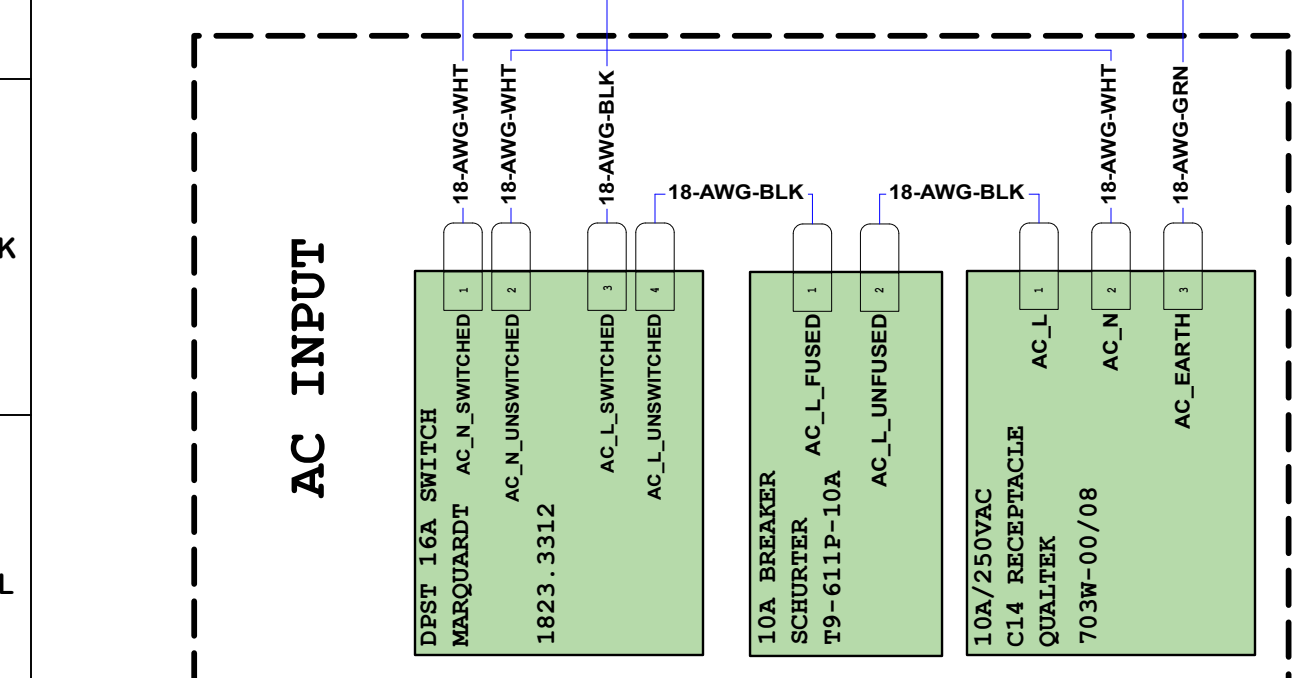

F Designed: JTN E Date: 2019/03/20 D REV: C C		Title: SUPER BIKES 3 DWG: SYSTEM DIAGRAM SHEET: 19 SHEETS: 3
Raw Thrills, Inc. 5441 Fargo Ave. Skokie, IL 60077 USA tel: 847.679.8373 fax: 847.679.	ANSI D	Description:

UPPER CABINET

COIN DOOR

LOWER MARQUEE [CA-4761]

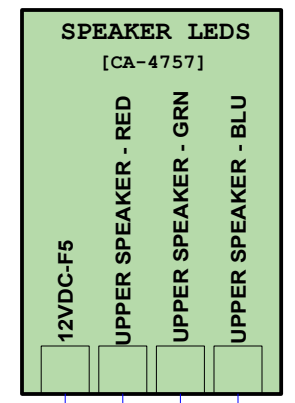
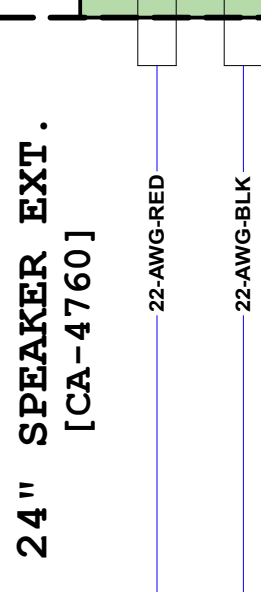
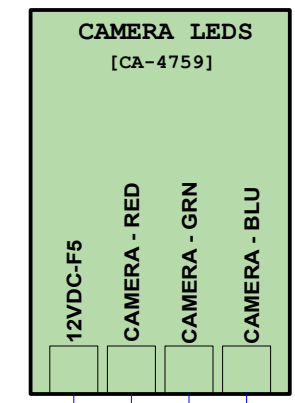
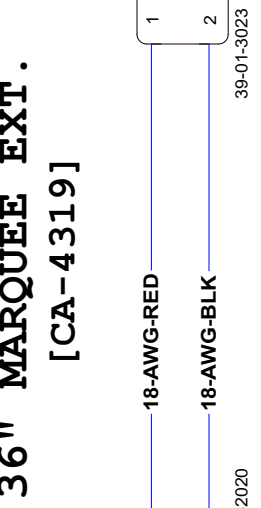
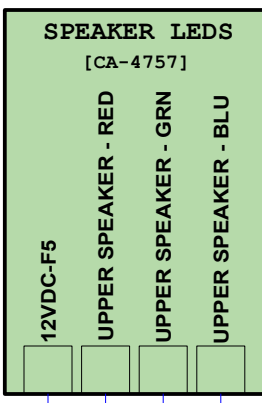
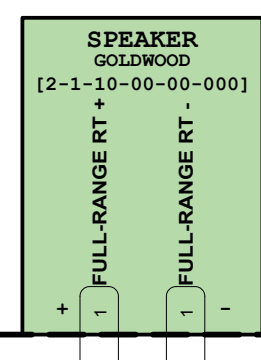
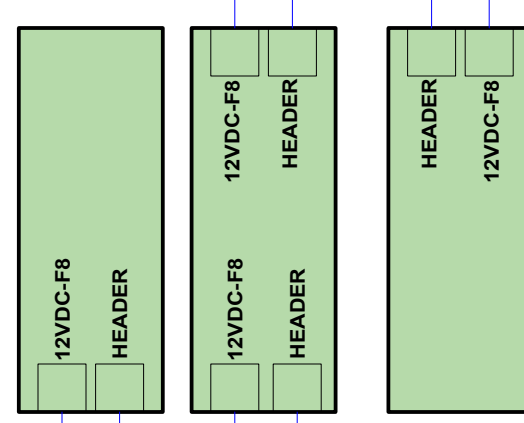

COIN DOOR EXT. [CA-3818]

COIN DOOR

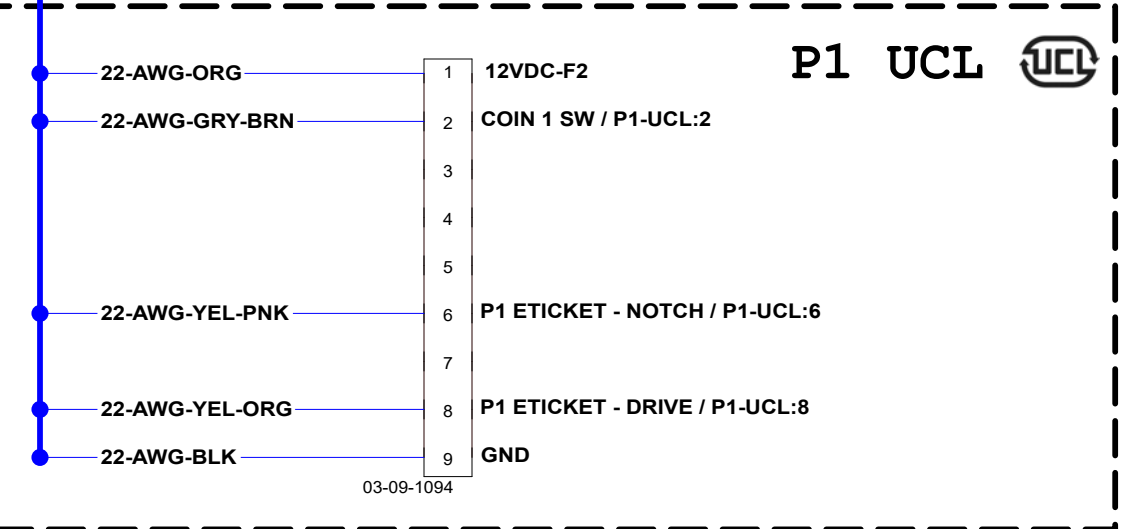
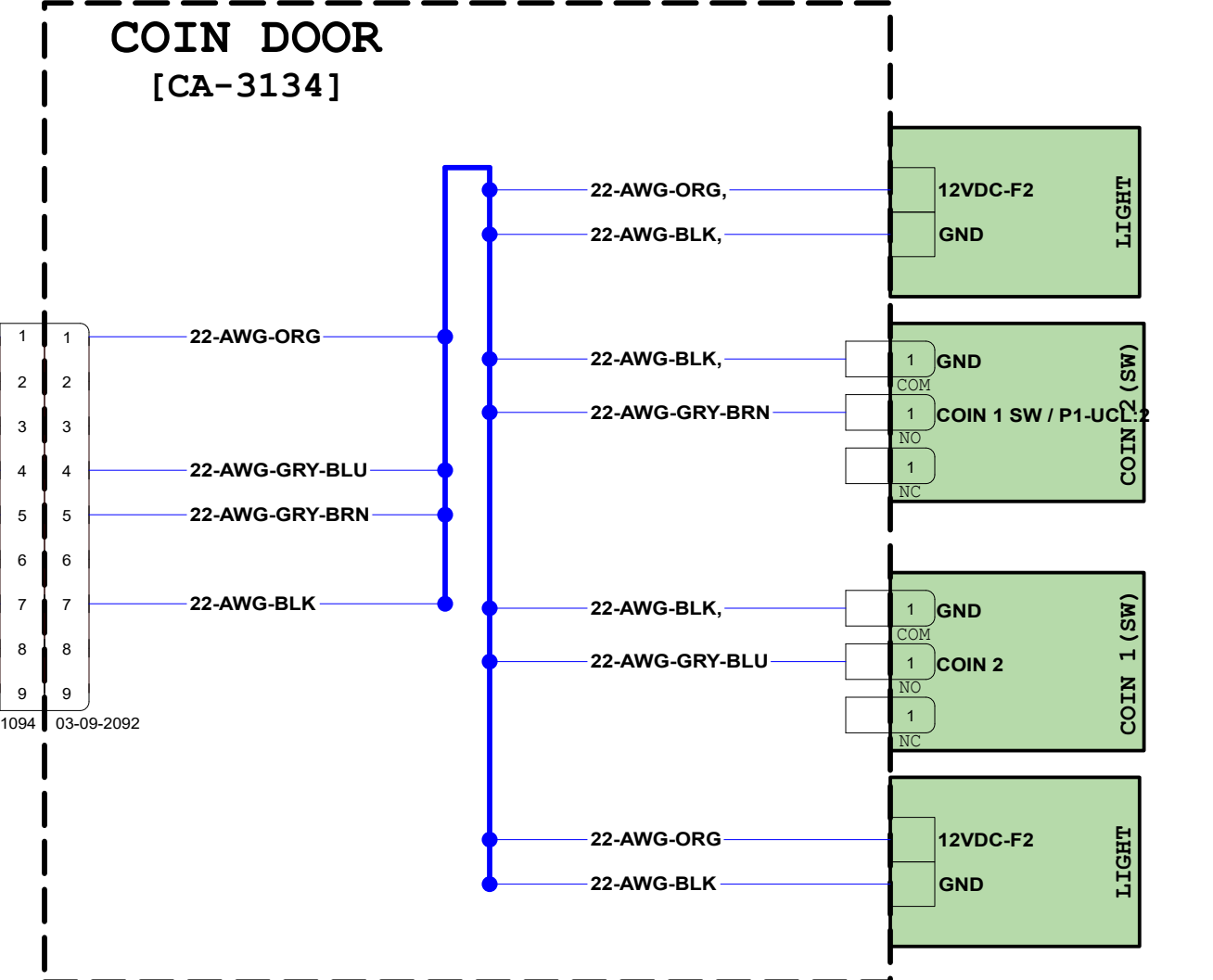
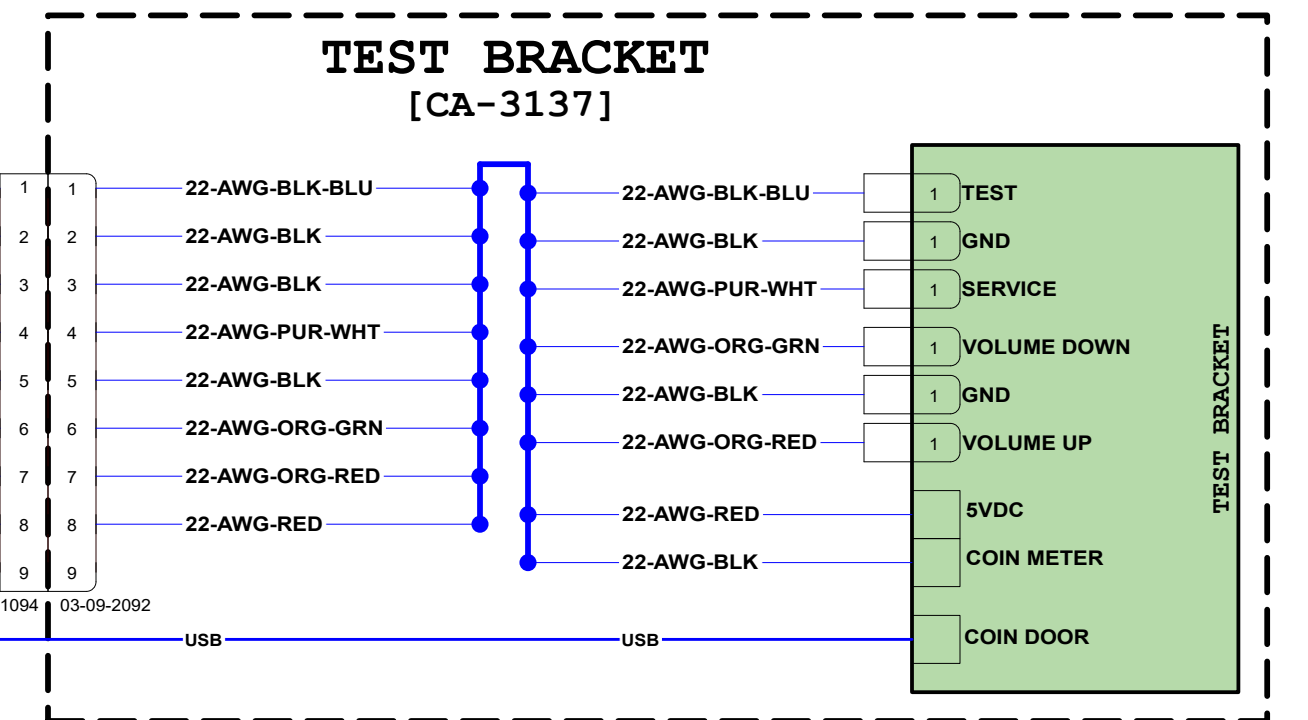
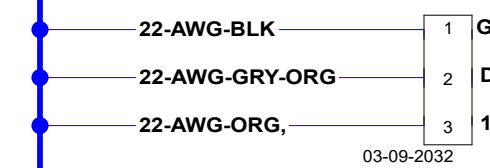

UPPER MAIN [CA-4767]

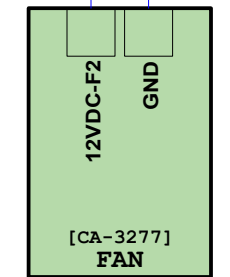
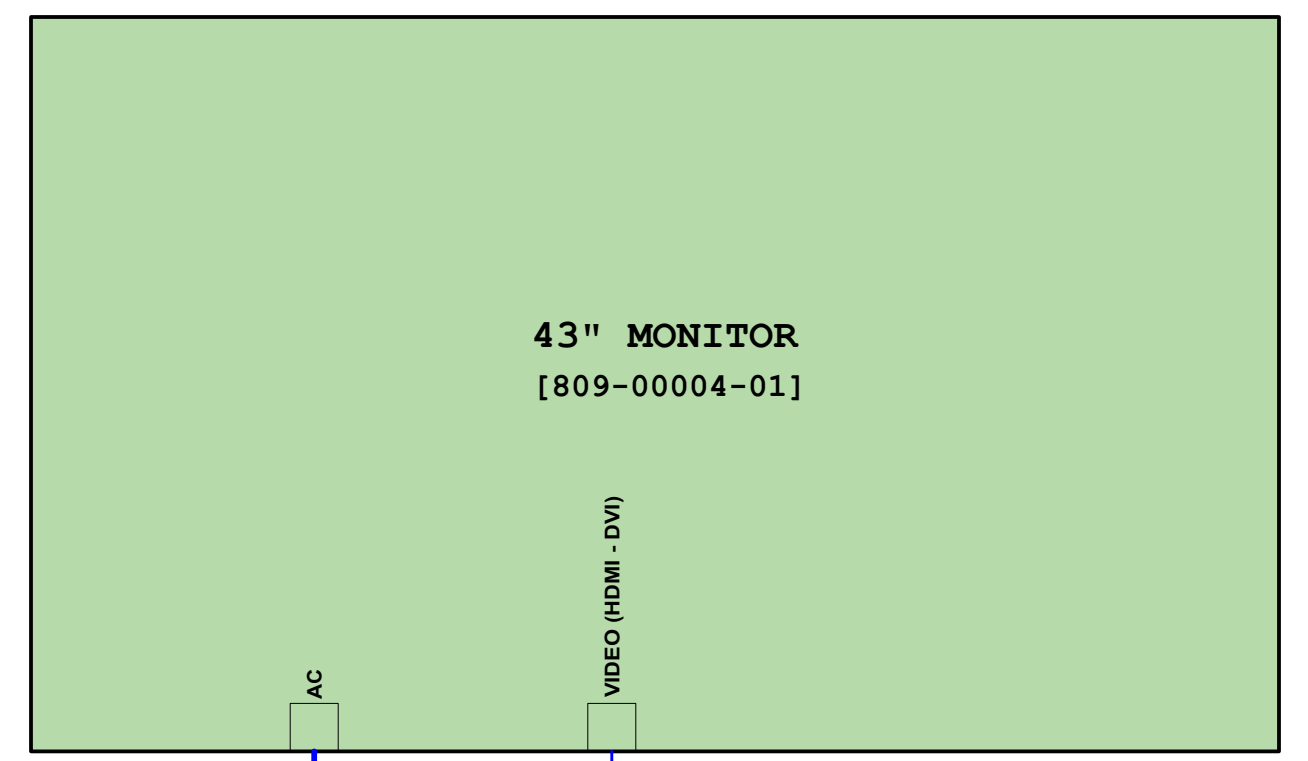
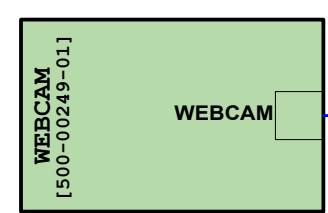
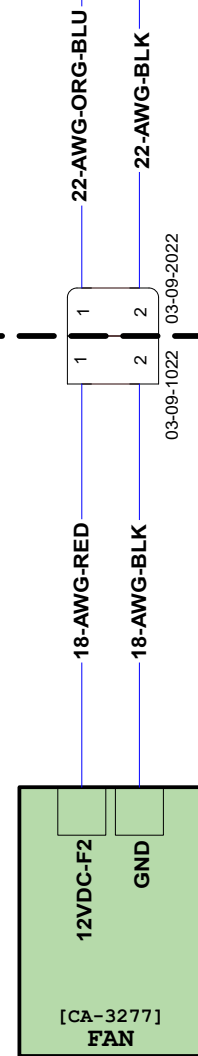

UPPER CABINET (B)

UPPER CABINET (A)

REV	F	Designed:	JTN	Date:	2019/03/20	REV	C	ANSI D
REV	E	Updates:	JTN	2019/04/18				
REV	D	INITIAL	JTN	2019/03/28				
REV	C	DESCRIPTION	JTN	2019/03/28				
REV	B							
REV	A							
REV								

Raw Thrills, Inc.
5441 Fargo Ave. Skokie, IL 60077 USA
rawthrills.com tel: 847.679.8373 fax: 847.679.

TITLE	SUPER BIKES 3
DWG	SYSTEM DIAGRAM
SHEET	2
SHEETS	3

BIKE

Main Bike Harness:
[CA-4764]

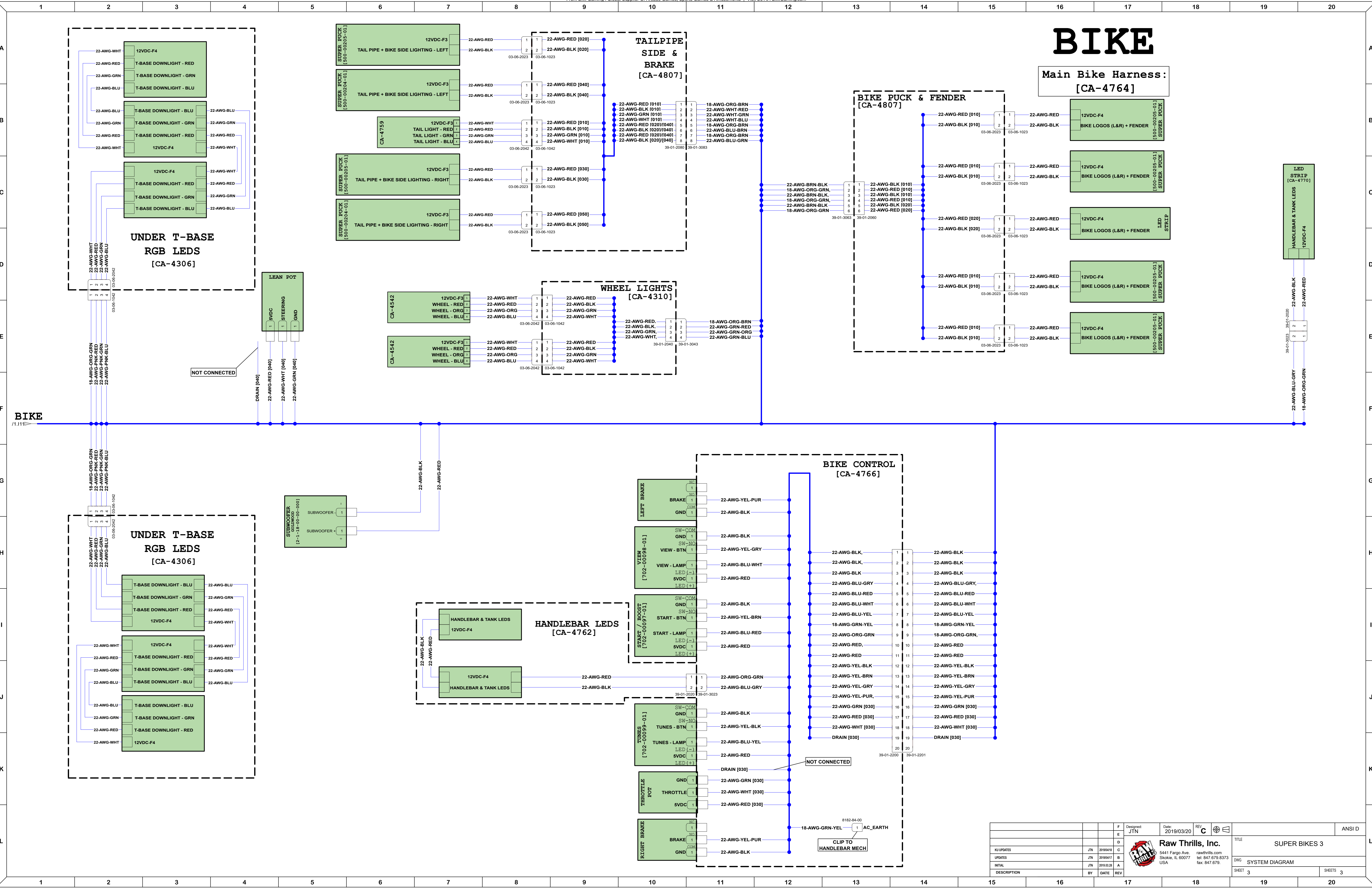

REV	DATE	BY	DESCRIPTION
F	2019/03/20	JTN	Initial
E		JTN	Updates
D		JTN	Updates
C		JTN	Updates
B		JTN	Updates
A		JTN	Initial

DESIGNED	DATE	REV	BY	DESCRIPTION
JTN	2019/03/20	C	JTN	Initial

RAW THRILLS	5441 Fargo Ave. Skokie, IL 60077 USA	rawthrills.com tel: 847.679.8373 fax: 847.679.
-------------	--	--

TITLE	ANSI D
SUPER BIKES 3	
DWG	SHEETS
SYSTEM DIAGRAM	3