

PUSHING POINTS

OWNER'S MANUAL

Ver.1.00



! WARNING

- For safety reasons, please read the manual first before plugging in machine.
- Please keep this manual properly for convenient reference as needed.

About This Manual

Thank you for purchasing this product.

The manual describes how to install, set up, use and maintain the product. The main purpose of the manual is to instruct how to operate the product correctly and safely. Please follow all the safety and warning instructions in the manual to avoid personal injury and product damage.

This product may only be maintained by a technician. A technician mainly refers to a person who has obtained a certificate of senior middle school related to mechanical engineering, electrical engineering or at a level equal to that of technical senior middle school graduates, and is engaged routinely in the maintenance, management, repair of amusement machine.

When transferring the ownership of this product, be sure to provide this manual with the machine.

For further information about the game and repair (including consumables), please contact our company.

© GuangZhou Wahlap Technology Corporation Limited All Rights Reserved.

Unauthorized reproduction of this document or any of its contents in any form is strictly forbidden.

Table of Contents

About This Manual

| | |
|---|-----------|
| 1. Safety Precautions | 1 |
| 1.1 Warning Stickers | 1 |
| 1.2 Placing Site | 1 |
| 1.3 Safety Precautions | 2 |
| 1.4 Precaution during Play | 3 |
| 1.5 Transporting and Moving | 3 |
| 1.6 Installing and Placing | 4 |
| 1.7 Caution & Warning Stickers | 5 |
| 2. Product Description | 6 |
| 2.1 Product Specification | 6 |
| 2.2 Overview | 7 |
| 2.3 Parts Name | 8 |
| 2.4 Shipment List | 9 |
| 2.5 Packing List | 10 |
| 2.6 Instructions for installation | 11 |
| 2.7 Warranty | 12 |
| 3. Game Description | 13 |
| 3.1 Appearance Design | 13 |
| 3.2 Game Introduction | 13 |
| 3.3 How to Play | 13 |
| 3.3.1 Modification about game-machine top/prize slide-way | 14 |
| 4. Test and Setting | 16 |
| 4.1 Test Mode | 16 |
| 4.1.1 Top Menu | 17 |
| 4.1.1.1 Prize Operation | 17 |
| 4.1.1.2 Meter | 18 |
| 4.1.1.3 Game History | 19 |
| 4.1.1.4 Error History | 20 |
| 4.1.1.5 Setting | 21 |
| 4.1.1.6 I/O Test | 24 |
| 4.1.1.6.1 Pusher Unit Test | 24 |
| 4.1.1.6.2 Shutter Test | 26 |
| 4.1.1.6.3 Coin In Test | 26 |
| 4.1.1.6.4 Switch&Sensor Test | 27 |
| 4.1.1.6.5 Led Test | 27 |
| 4.1.1.6.6 7Seg Test | 28 |
| 4.1.1.6.7 Sound Test | 28 |
| 4.1.1.6.8 Aging Test | 29 |

| | | |
|-----------|---|-----------|
| 4.1.1.7 | Data Clear | 30 |
| 4.1.1.8 | Rom Version | 30 |
| 4.2 | Error Display | 31 |
| 4.3 | Error List | 31 |
| 4.4 | Sound List | 37 |
| 4.5 | Main-board DIP SW setting | 38 |
| 4.6 | Displayed contents on the digital board at the time of coining. | 38 |
| 5. | Maintenance and Service | 39 |
| 5.1 | Maintenance and service | 39 |
| 5.2 | Part Replacement | 40 |
| 5.2.1 | Change LED with casing | 40 |
| 5.2.2 | Replacement of ceiling lamp | 40 |
| 5.2.3 | Change door-frame acrylic soft-lamp-bar | 41 |
| 5.2.4 | Change prize-outlet soft-lamp-bar | 42 |
| 5.2.5 | Change control-panel soft-lamp-bar | 42 |
| 5.2.6 | Change control-panel joystick | 44 |
| 5.2.7 | Change control-panel button | 45 |
| 5.2.8 | Change control-panel digital-board (7SEG) | 45 |
| 5.2.9 | Replacement of left/right sensors | 46 |
| 5.2.10 | Replacement of horizontally-moving sensors | 46 |
| 5.2.11 | Replacement of front/rear sensors | 47 |
| 5.2.12 | Replacement of longitudinally-moving sensors | 47 |
| 5.2.13 | Replacement of upper/lower limit sensors | 47 |
| 5.2.14 | Replacement of colliding-sensors | 48 |
| 5.2.15 | Replacement of sealing-plate opening/closing status sensors | 48 |
| 5.2.16 | Replacement of sealing-plate opening/closing position sensors | 48 |
| 5.2.17 | Replacement of optical-eye box | 49 |
| 5.2.18 | Replacement of sealing-plate motor | 49 |
| 5.2.19 | Replacement of longitudinally-moving motor | 50 |
| 5.2.20 | Replacement of horizontally-moving motor | 51 |
| 5.2.21 | Replacement of moving-up/down motor or polyurethane roller | 52 |
| 5.2.22 | Replacement of prize net | 52 |
| 5.2.23 | Replacement of top | 53 |
| 5.2.24 | Replacement of speaker | 53 |
| 5.2.25 | Replacement of coin box | 54 |
| 5.2.26 | Change leakage switch | 54 |
| 5.2.27 | Replacement of fuse | 55 |
| 5.2.28 | Change power-box | 55 |
| 5.2.29 | Replacement of PVC | 56 |
| 5.2.30 | Replacement of moving components | 56 |
| 5.2.31 | Replacement of sealing-door spring | 57 |

| | | |
|-----------|--|-----------|
| 5.2.32 | Replacement of prize baffle | 58 |
| 5.2.33 | Specification for height-adjusting net | 58 |
| 5.2.34 | Specification for the height of the ramp net | 59 |
| 5.2.35 | Descriptions for damping-adjustable hinge | 60 |
| 5.2.36 | Description for power socket. | 60 |
| 5.2.37 | Description for LCD position and operation steps | 61 |
| 5.2.38 | Descriptions for prize-rack. | 61 |
| 5.2.39 | Descriptions for hole-cover of lower cover-plate | 62 |
| 5.3 | Replacement or repairing of main-board. | 63 |
| 6. | Assembly. | 65 |
| 6.1 | Assembly tree diagram | 65 |
| 6.2 | Total components(PP-0000000) | 66 |
| 6.3 | Frame sub-components(PP-0100000) | 67 |
| 6.3.1 | Frame primary-components(PP-0101000) | 68 |
| 6.3.2 | Power-box components(PP-0102000) | 69 |
| 6.3.3 | Cashbox components(PP-0103000) | 70 |
| 6.3.4 | Prize-lane components(PP-0104000) | 71 |
| 6.3.5 | Prize-outlet mask components(PP-0105000) | 72 |
| 6.3.6 | PCB-box components(PP-0106000) | 73 |
| 6.3.6.1 | PCB components(PP-0106000-A) | 74 |
| 6.3.7 | Glass components on both sides(PP-0107000) | 75 |
| 6.3.8 | TILT components(PP-0108000) | 76 |
| 6.3.9 | Eyelet sensor components(PP-0109000) | 77 |
| 6.3.9.1 | Optical-eye box(PP-0109000-A). | 78 |
| 6.3.10 | Inner supporting-iron components(PP-0110000) | 79 |
| 6.3.11 | Bottom sealing-plate components(PP-0111000) | 80 |
| 6.3.12 | Prize sealing-plate door components(PP-0112000) | 81 |
| 6.3.13 | Low-voltage power module(PP-0113000) | 82 |
| 6.3.14 | Door-closing motor components(PP-0114000) | 83 |
| 6.4 | Control-panel components(PP-0200000) | 84 |
| 6.5 | Coin-door components(PP-0300000) | 85 |
| 6.6 | Large door-frame components(PP-0400000) | 86 |
| 6.6.1 | Door-frame acrylic components(PP-0401000) | 87 |
| 6.6.2 | Large acrylic-door components(PP-0402000) | 88 |
| 6.7 | General moving part components(PP-0500000) | 89 |
| 6.7.1 | Horizontally-moving front-rail components(PP-0501000) | 90 |
| 6.7.2 | Horizontally-moving rear guide-rail components(PP-0502000) | 91 |
| 6.7.2.1 | Horizontally-moving roller-plate components(PP-0502000-A) | 92 |
| 6.7.3 | Longitudinally-moving rail components(PP-0503000). | 93 |
| 6.7.3.1 | Longitudinally-moving motor components(PP-0503000-A) | 94 |
| 6.7.3.2 | Longitudinally-moving frame components(PP-0503000-B) | 95 |

| | | |
|----------------------------|---|------------|
| 6.7.4 | Horizontally-moving motor components(PP-0504000) | 96 |
| 6.7.5 | Total jacking-rod components(PP-0505000) | 97 |
| 6.7.5.1 | Jacking-rod fixing-wheel components(PP-0505000-A) | 98 |
| 6.7.5.2 | Jacking-rod motor components(PP-0505000-B) | 99 |
| 6.7.5.3 | Jacking-rod sensor components(PP-0505000-C) | 100 |
| 6.7.5.4 | Jacking-rod components(PP-0505000-D) | 101 |
| 6.8 | Ramp net components(PP-0700000) | 102 |
| 6.8.1 | Net components(PP-0701000) | 103 |
| 6.8.2 | Prize ramp-panel components(PP-0702000) | 104 |
| 6.8.3 | Net movable-pin components(PP-0703000) | 105 |
| 6.8.4 | Net front-pillar components(PP-0704000) | 106 |
| 6.9 | Prize-lane cover-plate components(PP-0800000) | 107 |
| 6.10 | Prize display-board components(PP-0900000) | 108 |
| 6.11 | POP components(PP-1000000) | 109 |
| 7. Printing Pattern | | 110 |
| 8. Wiring Diagram | | 111 |
| After-Sales Service | | |

1. Safety Precautions

1.1 Warning Stickers

In order to avoid injury to related people and damage to property, please observe the followings:

PLEASE READ FIRST

- The following marks can be used to indicate the magnitudes of risk and damage caused by ignorance or improper operation:



means “may result in serious injury or death”



means “may result in minor injury or property damage”

Serious Injury: refers to the situations in which hospital treatment or long-term treatment will be accepted because of losing sight, getting hurt, getting burnt, electric shock, fracture or intoxication.

Minor Injury: refers to the cases that there is no need to go to hospital or accept long-term treatment.

Property Damage: refers to the damage of house, facility, or hurt of livestock and pet

1.2 Placing Site

Warning

- please make sure the place line has been grounded before product installation, setup, testing, operation or repair
- This machine is designed for indoor use only. Never install the machine outdoors. Meanwhile, please avoid the following locations indoor:
 - Direct sunlight, water leakage, damp and high temperature places.
 - Near Flammable, volatile, or/and dangerous substance.
 - Slope, unstable places or locations subject to frequent vibration.
 - Near emergency exit, fire extinguisher or similar equipment.
- The rear part has the vent for heat emission from PC or screen. Don't place anything nearby to avoid game failure.
- Provide a space of minimum 30cm between the rear of the machine and the wall for good ventilation and heat emission

1.3 Safety Precautions

The owner shall pay attention to the followings when placing, checking and repairing machine to insure player's security and avoid damage:

Warning

- please check the voltage is 110V or 220V before the machine connects to the power supply, or it may cause a fire or electric shock.
- Make sure to plug the game into 110V or 220V main outlet to avoid fire and electric shock.
- Make sure to turn off the power when performing maintenance and service to avoid electric shock or short circuit.
- Do not unplug or plug the plug instantly.
- Don't touch the power plug with a wet hand to avoid electric shock.
- Don't expose the power cord/grounding line on the passageway. Failure to do this will damage the power cord, causing electric shock or short circuit.
- Don't lay anything near the power cord to avoid fire.
- Do not pull the power cord when unplugging, please hold the plug to avoid power cord damage, causing fire or electric shock.
- In case of power cord damage, please contact the local distributor for replacement
- Only use fuse and spare parts specified by our company
- Connect the connector firmly and tighten the screws.
- It is forbidden to push or pull the game-machine in order to prevent the accidental danger.
- Do not dismount, replace or convert the product without our permission in order to avoid damage and human injury due to improper operation.
- Check and maintain the machine regularly.
- Keep "Warning stickers" clean and legible. Replace it immediately when the words are not legible or the dirt can't be removed.
- Please contact our service center when performing any work that is not described in this manual, and follow the instruction provided.

1.4 Precautions during Play

Caution

- In order to avoid injury and accident during play, the following people shall not play the game:
 - People who are injured or less mobile.
 - Person with poor health condition, such as hypertension or heart disease.
 - Person wearing high-heeled or slippery shoes.
 - Person who can't touch the pedal.
 - Pregnant woman, drunk people.
- When a player feels uncomfortable during play, remind the person to have a break, or stop playing.
- Make sure the player reads the warning labels and other indications, and plays in accordance with the instructions to avoid accidents such as electric shock and short circuit.
- Bystander shall not operate any button when the player is playing the game to avoid unnecessary trouble.
- It is forbidden to push or pull the game-machine in order to prevent the accidental danger.

1.5 Transporting and Moving

Caution

Transporting

- When transporting the machine with an elevator, be sure to employ "Lift Point" to prevent accident and damage to the machine.
- To prevent movement when transporting the machine on a vehicle, please fix the casters and fully retract the adjusters. Failure to do this may cause damage to the machine.
- When carrying the machine with a forklift, be sure to insert the fork to fork position and lift stably. If not, it may cause accident and damage to the machine.
- The Acrylic of the machine is fragile. High precision components are required for vibration or shock resistance.

Moving

- Before moving the machine, unplug the power plug to prevent accident. Don't damage the cord.
- Pay attention to the obstructions and uneven surface when moving the machine to prevent accident and damage to the machine.
- Fully retract all adjusters before moving to prevent accident and hazard.
- Make sure to use at least two persons to conduct the above work to avoid accident and injury
- Pay attention to the moving direction, see fig.



1.6 Installing and Placing

Pay attention to the following when placing the machine.

Caution

- Place the machine on the flat and slip resistant area.
- Use the adjusters to fix the machine (See diagram 1)
 1. Loosen the nuts for the adjusters (clockwise), tighten the bolts with a wrench (clockwise).
 2. Tighten the nut firmly (counter clockwise) and fix it well.

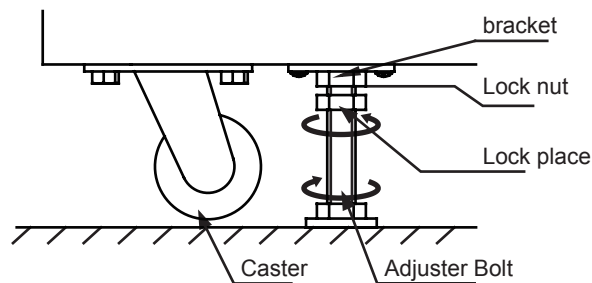

Diagram (1)

- Provide a space of minimum 30cm between the rear of the machine and the wall for good ventilation and heat emission (See diagram 2).

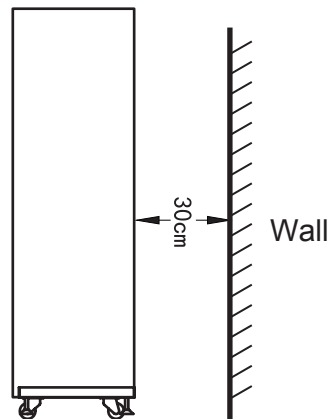
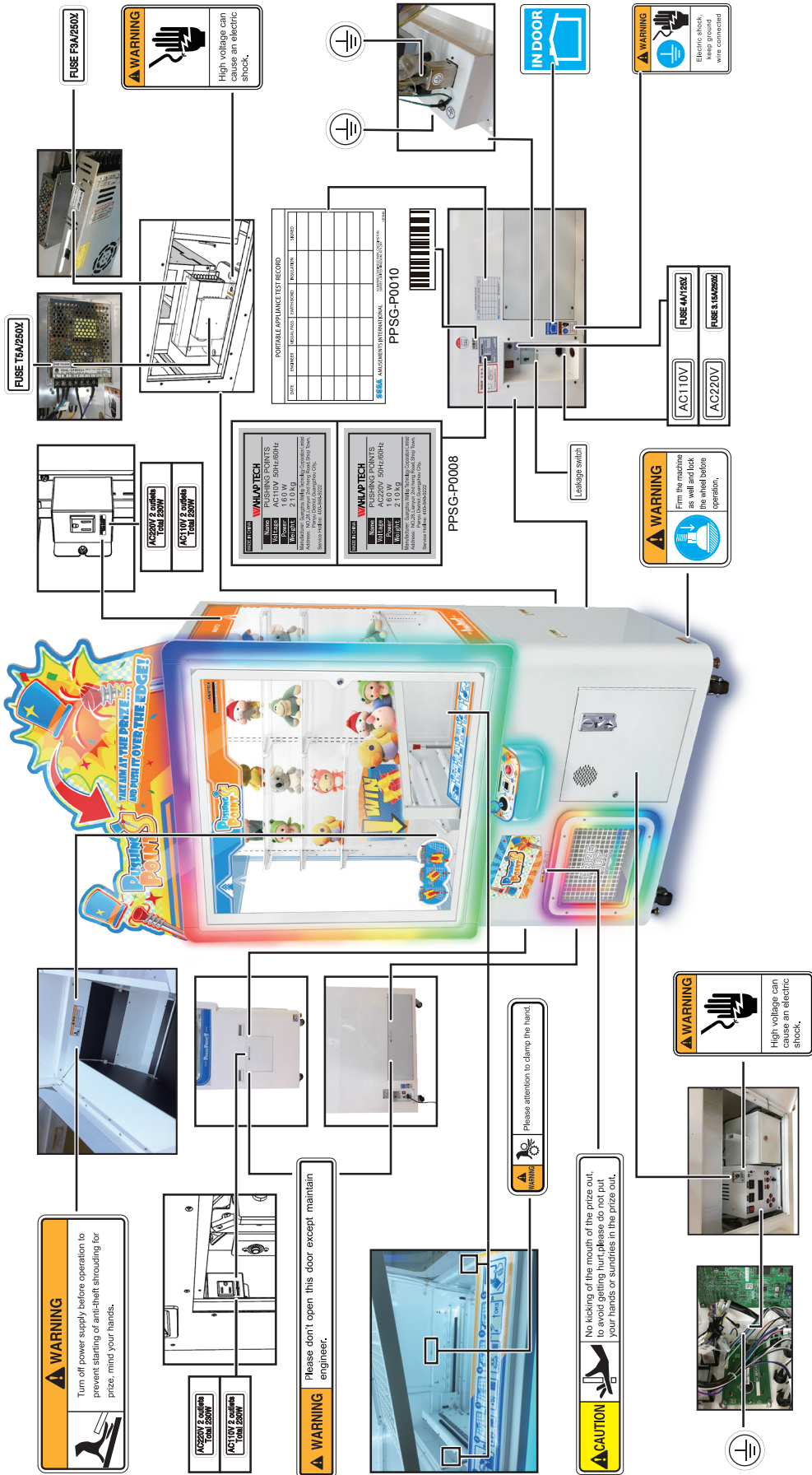

Diagram (2)

1.7 Caution & Warning Stickers



2. Product Description

2.1 Product Specification

| | |
|-----------------------|------------------------|
| ■ Location | Indoor Only |
| ■ Dimension | 1220(W)×795(D)×2566(H) |
| ■ Rated Voltage | 220V |
| ■ Frequency | 50Hz |
| ■ Power Consumption | 160 W |
| ■ Game-machine weight | 210 kg |
| ■ Temperature Range | 5~40 °C |
| ■ Max size of prize | 265(W)×350(D)×300(H) |
| ■ Max weight of prize | 1 kg |
| ■ Prize net size | 560(W)×590(D) |

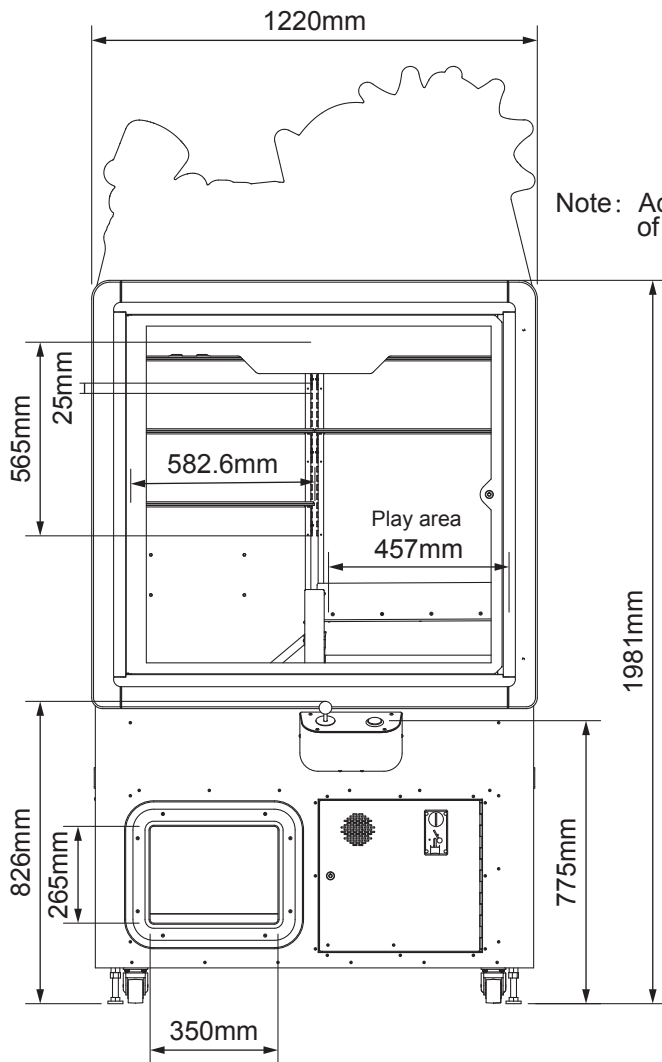

■ Front View

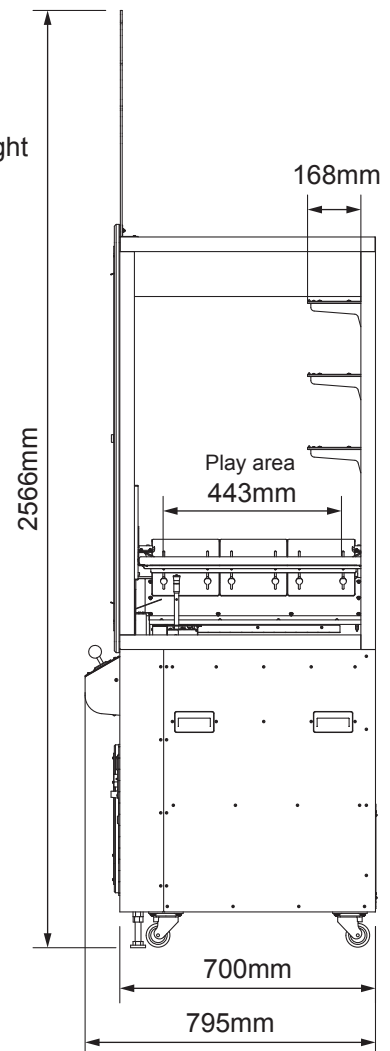

■ Side View

2.2 Overview

■ Side View

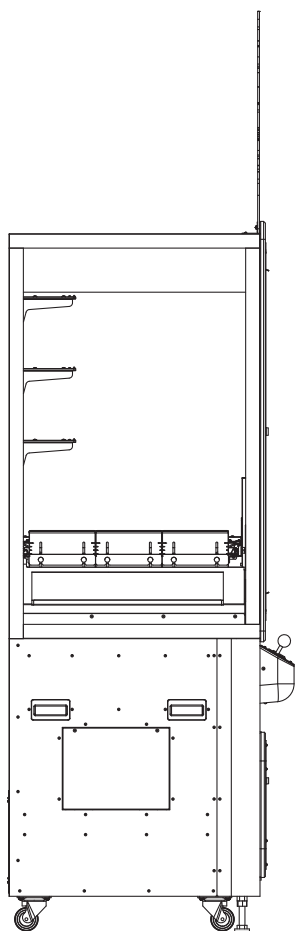

■ Rear View

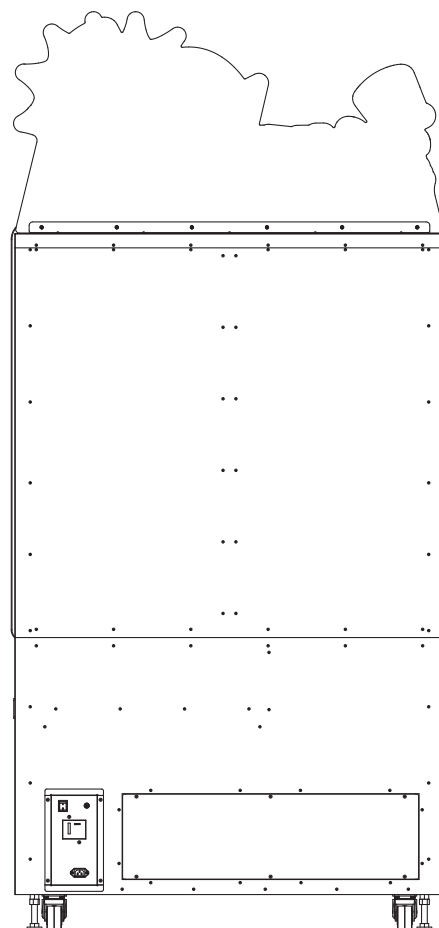

■ Top View

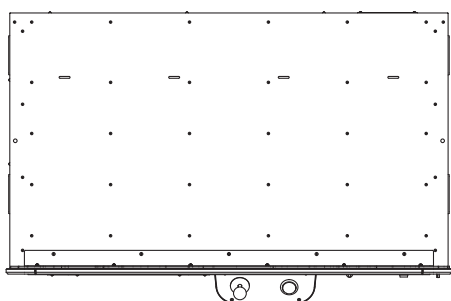

■ Bottom View

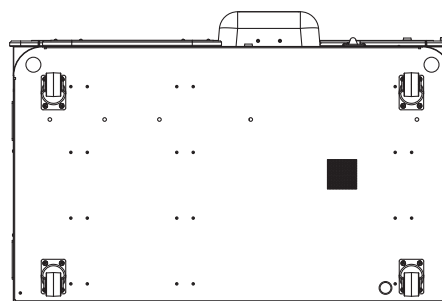

2.3 Parts Name

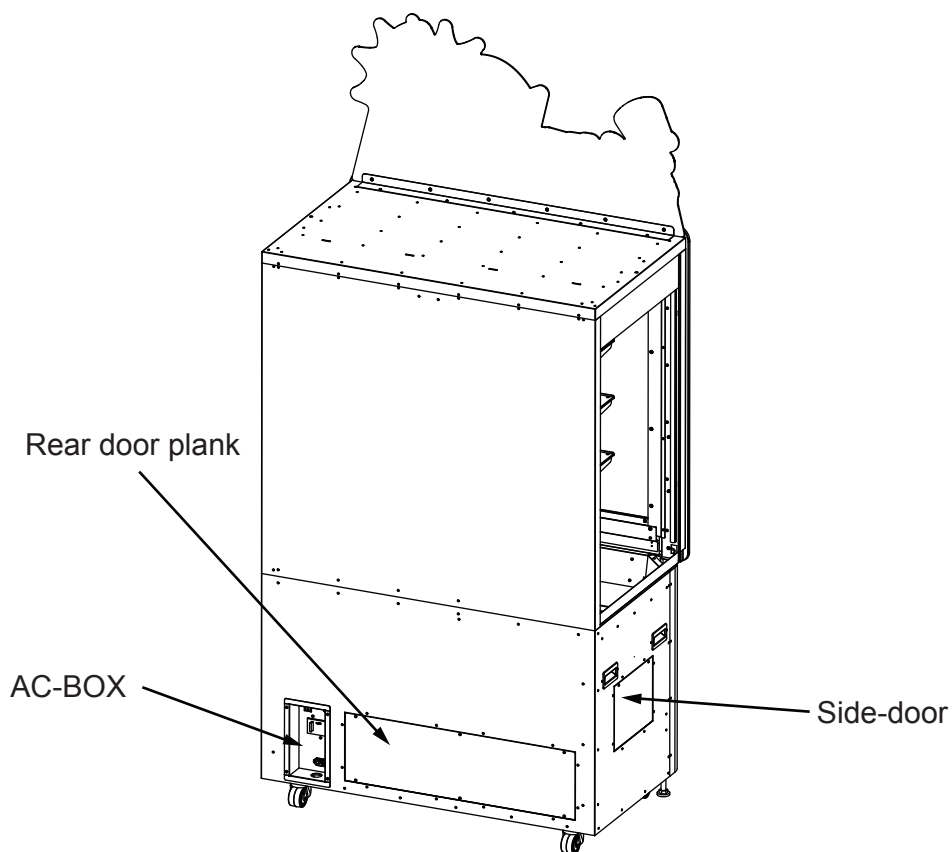
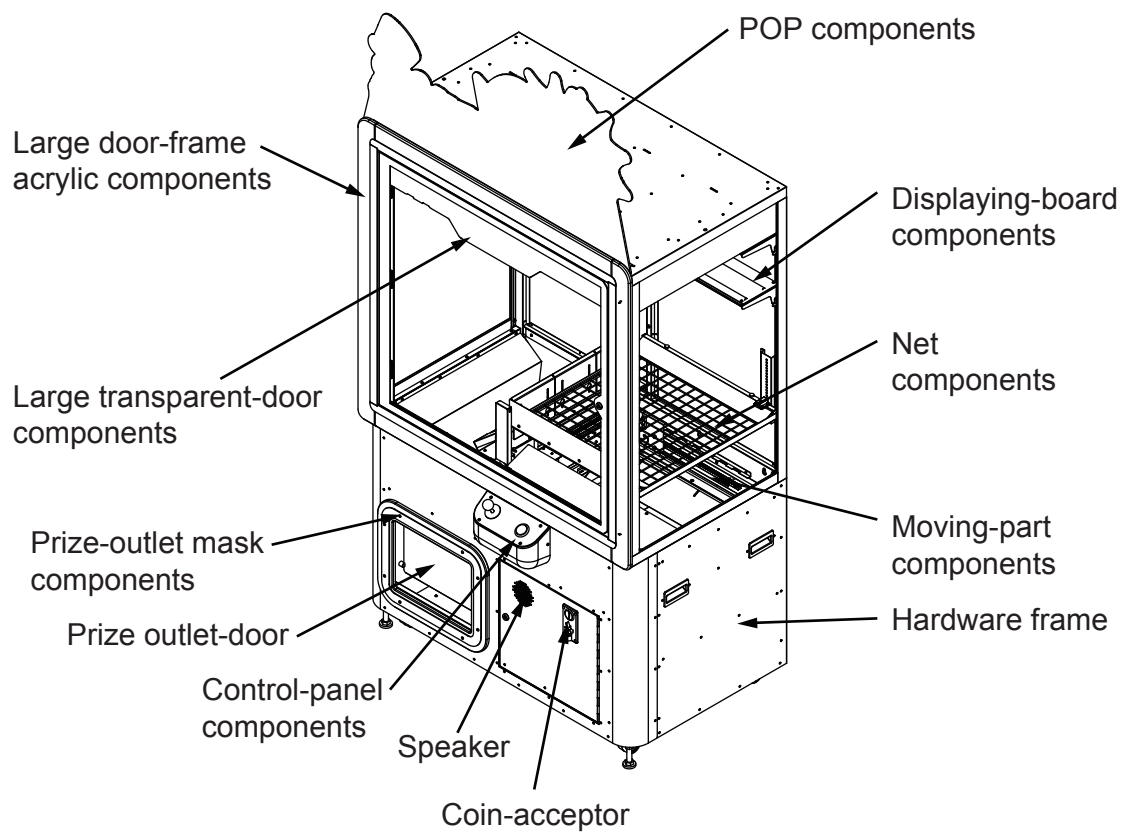

2.4 Shipment List

■ Modes of packing

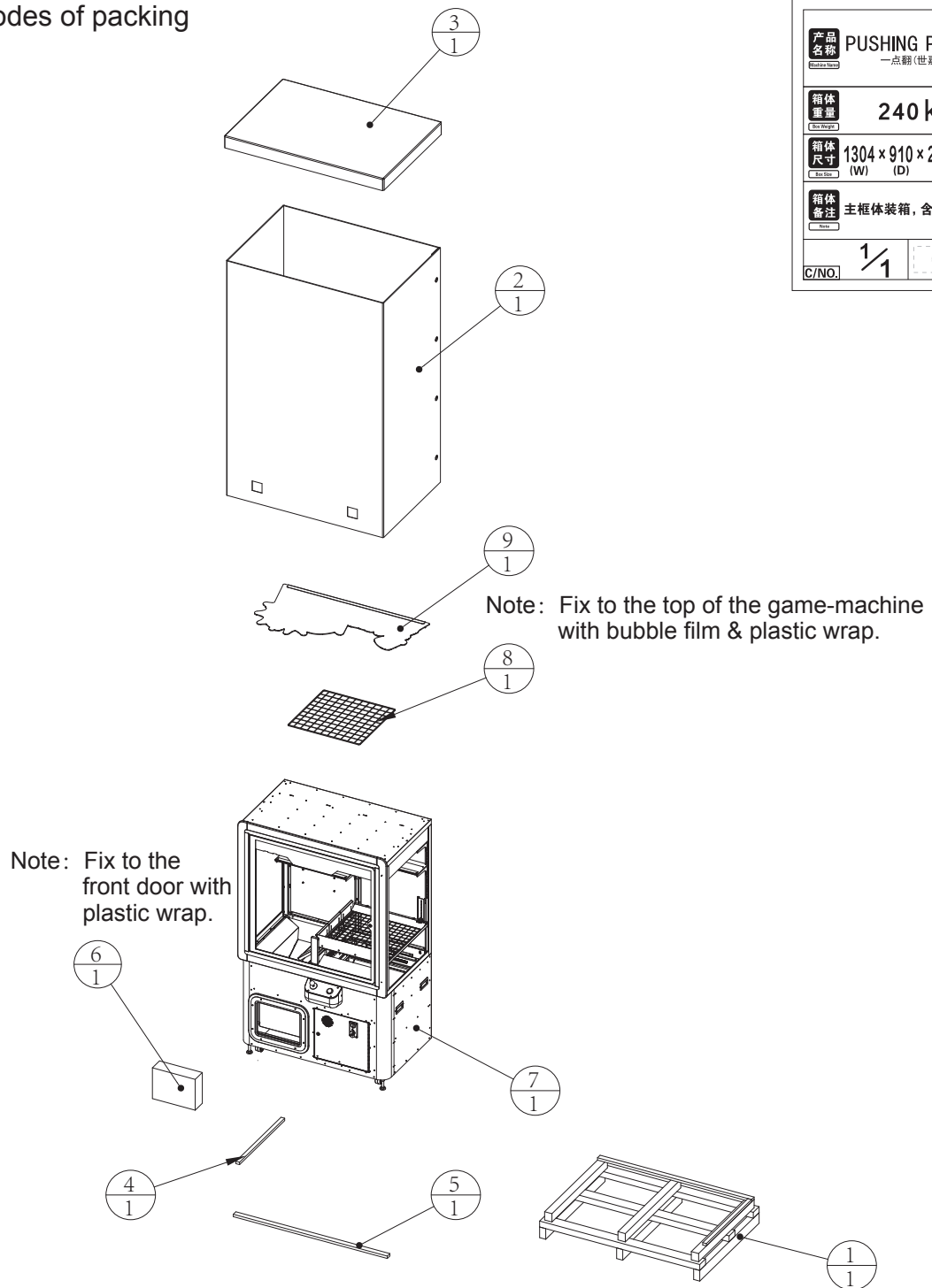







| |
|---|
| 产品名称 PUSHING POINTS 一点翻(世嘉版) |
| 箱体重量 240 kg |
| 箱体尺寸 1304 x 910 x 2127 mm (W) (D) (H) |
| 箱体备注 主箱体装箱, 含附属品箱 |
| C/NO. 1/1 |

| | | | | | |
|----|-------------|----------------------|------------------------------|-----|------|
| 9 | PP-1000000 | POP components | | 1 | |
| 8 | PP-0701A10 | Large prize net | | 1 | |
| 7 | PP-0000000 | Total components | | 1 | |
| 6 | | Accessory box | | 1 | |
| 5 | PP-9901E05 | No.2 frame limit-bar | Solid wood 20*40*1260 | 1 | |
| 4 | PP-9901E04 | No.1 frame limit-bar | Solid wood 20*30*700 | 1 | |
| 3 | PP-9901E03 | Frame cover | Water resistance 2C 850g T-7 | 1 | |
| 2 | PP-9901E02 | Frame enclosure | Water resistance 2C 850g T-7 | 1 | |
| 1 | PP-9901E01 | Frame platform | | 1 | |
| SN | Drawing No. | Name | Materials/specifications | Qty | Note |

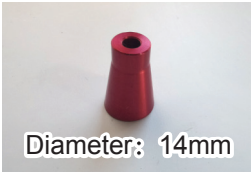
2.5 Packing List

Please check the following items after purchasing our product. If any part missing or damaged, please contact our sales person!

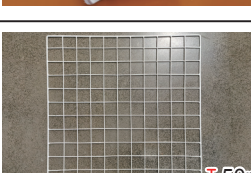
| Description | Specification | Quantity | Remarks |
|-----------------------------------|-----------------------------------|----------|---|
| Power cord (two-end three-pin) | 3m (1.0mm ²) 250V | 1 |  |
| Lock of same size B17 key | B17 key, No.6687 | 2 |  |
| Large top | 5052-O | 1 |  Diameter: 25mm |
| Straight top | 5052-O | 1 |  Diameter: 14mm |
| Instructions | Art paper | 1 |  |
| Fuse tube | 218 series T3.15A/5×20 250V | 1 |  |
| Long prize baffle | PC-3.0T | 3 |  |
| Large prize net | | 1 |  50mm 50mm |

2.6 Instructions for installation

- Fix POP components to the top of the game-machine with 5 screws.

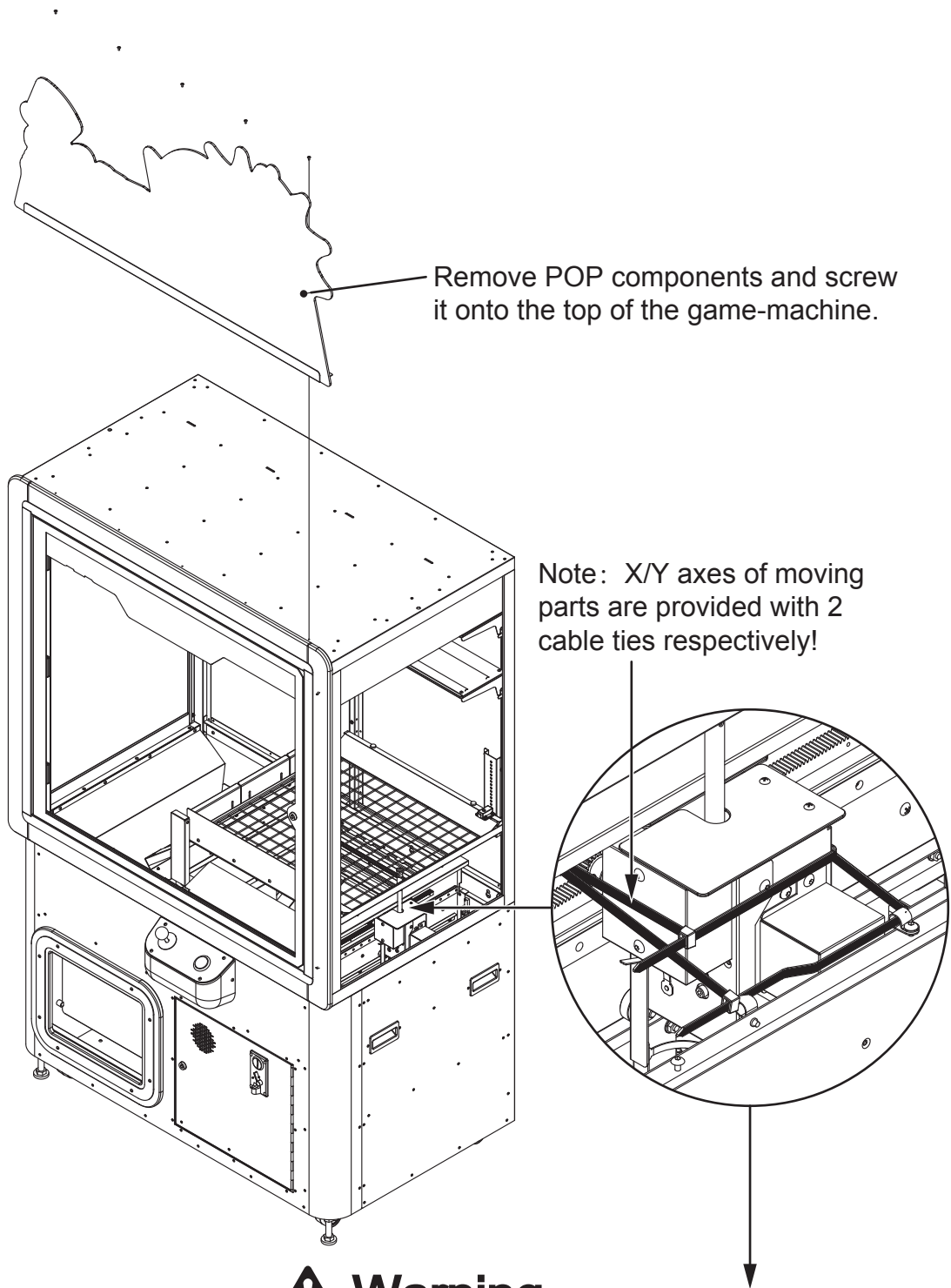

Warning

- Before the game-machine is powered on, cut off the cable ties at this position (for fixing X/Y axes of moving parts during transportation). On the contrary, when the game-machine is moved, the position must be tightened with the cable ties!

2.7 Warranty

■ Scope

- Inquiry regarding product can be assisted for free.
- The warranty scope for consumables and durables may differ from product to product. Please contact our after-sales service center for detailed information. The right of final interpretation is reserved.

■ Exclusive

- Damage caused by force majeure such as god will.
- Failure caused by carelessness, such as water contact, falling down, toppling, knocking.
- Failure caused by disobeying the instructions in this manual.
- Failure caused by operating the machine on inappropriate site.
- Change the original design and configuration for the game without notice.
- Failure to perform regular service and clean.
- Failure to fix the product in line with the manual's requirement.
- Malfunction or part damage caused by electromagnetic interference other electronic equipments generated.

■ Non-warranty Consumables

- Light tube and bulb
- Button lamp and switch
- Fragile items
- Solenoid
- Other spare parts

3. Game Description

3.1 Appearance Design

The color of "PUSHING POINTS" is mainly white and the game-machine is designed very simply and elegantly. After it is powered on, its lamp is bright and dazzling. The game-machine can display different styles by replacing 3 pieces of PVC. In the gaming area, there are 5 layers of prize-racks. The positions of the prize-racks can be adjusted according to the sizes of the prizes. The different sizes of prizes can be placed on the grid. The player can get the prizes on the grid by challenging!

3.2 Game introduction

"PUSHING POINTS" is a single-player game that tests the player's reflexes. After the coins are put in, the player can use the joystick to control the left/right movement of the jacking-rod to determine its position within 30s and then press the button to jack the prize. If the prize is not jacked, the player will not get the prize. If the prize is jacked, the player will get the prize!

3.3 How to play

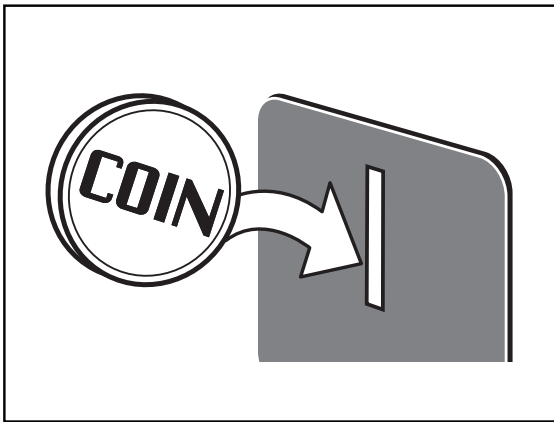

1. Put in the coins.

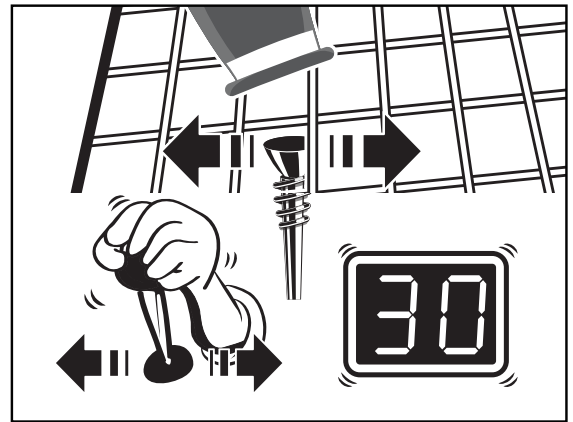

2. Select the prize and control the left/right movement of the jacking-rod by using the joystick.

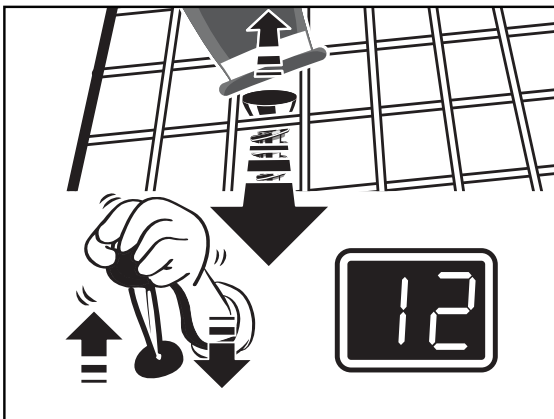

3. Then use the joystick to control the left/right movement of the jacking-rod to aim at the target.

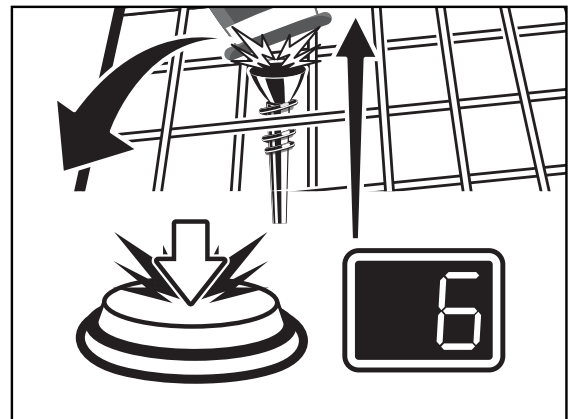

4. Press the button and jack the prize by use of the jacking-rod .

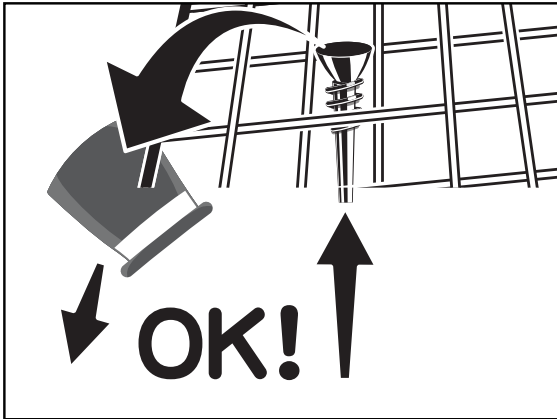

5. When the prize is jacked by the jacking-rod, the player can get the prize successfully!

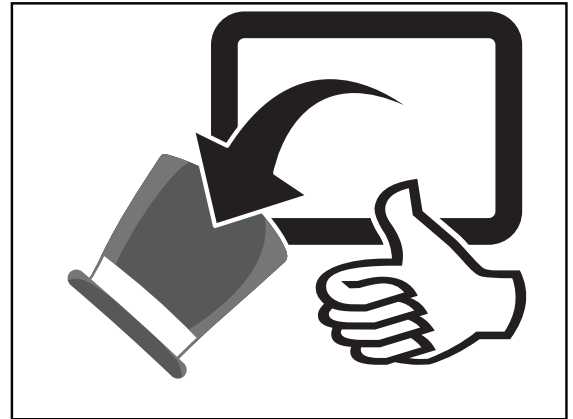

6. The player can get the prize at the prize outlet!

3.3.1 Modification about game-machine top/prize slide-way

■ Its top is provided with screws and nuts that can be modified into various operating methods.

- ① Its top is provided with 7 fixable positions.
- ② Use the rope to fix the pipe, as shown in the picture. The prize can be hung onto the round-pipe (Ancillary modified-parts to the game-machine)

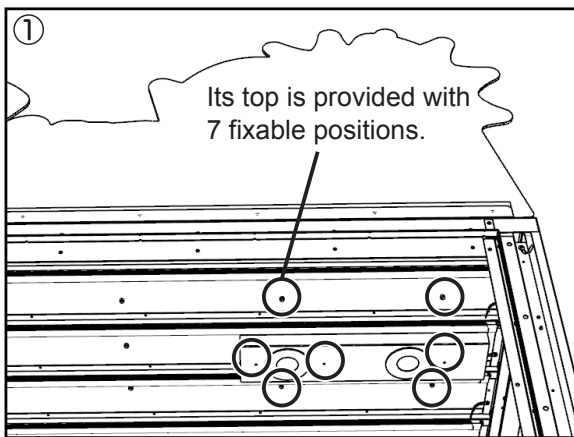

■ The prize slide-way is provided with screws and nuts that can be modified into various operating methods.

- ① The prize slide-way is provided with 8 fixable positions.
- ② This is an example of a game where you append a screen and put a candy ball on it. (no modified parts are attached to the game-machine)

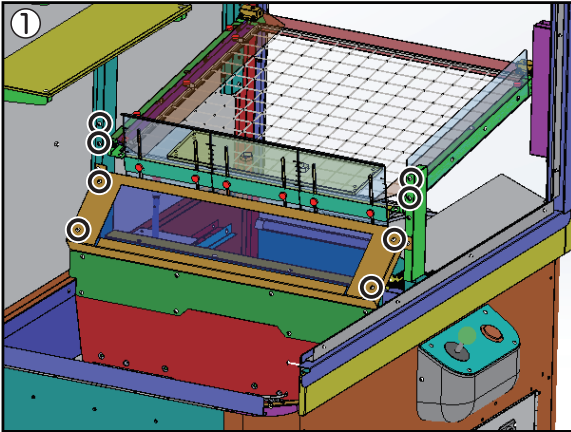

※ For the prize-setting or award-rate, refer to other operation manual. Please consult the sales store for details.

4. Test and Setting

4.1 Test Mode

【Basic operation and service-panel】

1. The service-panel can be seen when the right access door is opened.
2. Turn on [TEST]. The various data will be displayed and the test-mode can be entered.
3. Use [↑] and [↓] on the service-panel to select the item. Press [SETTING] to confirm and press [BACK] to return.
4. If [TEST] is changed to "OFF", the game mode will be restored automatically.

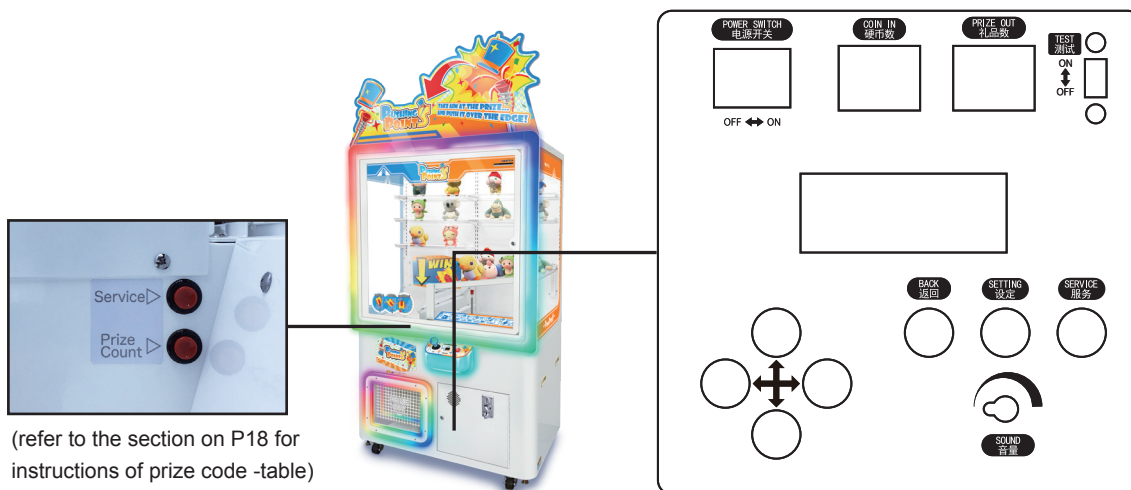

【Test-mode classified-catalogue】

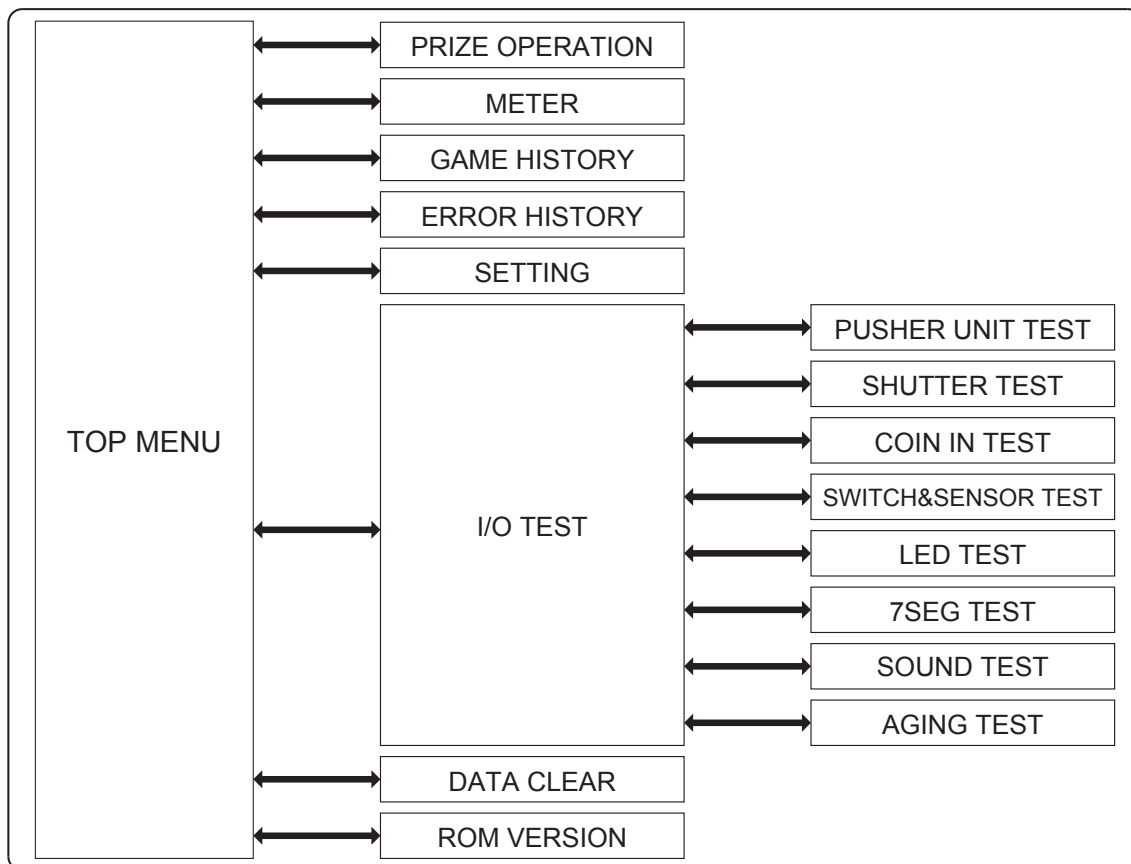

4.1.1 TOP MENU

1. By pressing [↑] and [↓], the arrow will move to select the corresponding item.
2. Press [SETTING] to confirm and the selected data or test mode will be entered.

For main menu, refer to P1



※The purpose of this feature is used to test the rationality of prize configuration before operation. There is no influence on the value and probability-control.

For main menu, refer to P2



4.1.1.1 PRIZE OPERATION

1. The service-panel can be seen when the right access door is opened.
2. Turn on [TEST]. The various data will be displayed and the test-mode can be entered.
3. By pressing [↑] and [↓], the arrow will point to "PRIZE OPERATION". Press [SETTING] to confirm.
4. Press [SETTING] to start the operation in the operation.
5. Press [SETTING] to stop the operation also in the operation.

Prize operation interface



| SN | Item Name | Contents |
|----|---|--|
| a | Prize operation status | <ul style="list-style-type: none"> ● Display the current status of the prize operation (OFF: Prize operation in stopping、ON: Prize operation in progress) |
| b | Performed jacking-up times | <ul style="list-style-type: none"> ● Performed jacking-up times ※9999 times can be displayed at most. When 9999 times are exceeded, the stopwatch will automatically stop. ※This value will always be displayed even if the prize operation interface is exited. |
| c | Numbers of failures caused by the collisions have been detected | <ul style="list-style-type: none"> ● Numbers of failures caused by the collisions have been detected ※9999 times can be displayed at most. When 9999 times are exceeded, the stopwatch will automatically stop. ※This value will always be displayed even if the prize operation interface is exited. |
| d | Error display | <ul style="list-style-type: none"> ● Once an error occurs, the error name is displayed here (For details, refer to Error List on P31-36) When an error occurs, the prize operation stops automatically. |

6. Return to the main menu by pressing [BACK].

4.1.1.2 METER

1. The service-panel can be seen when the right access door is opened.
2. Turn on [TEST]. The various data will be displayed and the test-mode can be entered.
3. By pressing [↑] and [↓], the arrow will point to "METER". Press [SETTING] to confirm.
4. By pressing [↑] and [↓], switch to the following page.

For revenue, refer to P1

| | | |
|------------|----------|-----|
| COIN IN | 00000010 | (a) |
| SERVICE IN | 00000114 | (b) |
| CREDIT CNT | 00000134 | (c) |
| GAME CNT | 00000142 | (d) |

For revenue, refer to P2

| | | |
|-----------|----------|-----|
| TOTAL OUT | 00000004 | (e) |
| HAND PAY | 00000000 | (f) |
| PUSH CNT | 00000145 | (g) |
| BUMP CNT | 00000039 | (h) |

| SN | Item Name | Contents |
|----|------------|--|
| a | COIN IN | ● Total coins put in from the coin-acceptor |
| b | SERVICE IN | ● Total coins calculated out by pressing the service-key |
| c | CREDIT CNT | ● The total games ※Include the games generated by pressing the service-key. ※The games in free mode are not included. |
| d | GAME CNT | ● Numbers of games played (that is, numbers of games actually played) ※The games in free mode are not included. In addition, because it does not include the cleared times, it is not entirely consistent with the total coins. |
| e | TOTAL OUT | ● Total given-prizes of all the prizes ※Including the prizes given by hand. |
| f | HAND PAY | ● The prizes given by hand When the prize cannot come out normally, press the prize count button in the frame to hop the stopwatch. Press the button for 1 second after the stopwatch will be hopped (given prizes). The button of the prize count can only be used in the current game.(The repeated press is also ineffective and the pressed times can't be saved either) |
| g | PUSH CNT | ● Jacking-up times (actual jacking-up times) ※ If the jacking-up is set to be repeated in 1 game, the repeated jacking-up times will also be counted. |
| h | BUMP CNT | ● The failures are detected by the colliding sensor within the jacking-up |



How to set the initial value, refer to P21-23 "4.1.1.5"

5. Return to the main menu by pressing [BACK].

4.1.1.3 GAME HISTORY

1. The service-panel can be seen when the right access door is opened.
2. Turn on [TEST]. The various data will be displayed and the test-mode can be entered.
3. By pressing [↑] and [↓], the arrow will point to "GAME HISTORY". Press [SETTING] to confirm.
4. By pressing [↑] and [↓], switch to the following page.

For game history, refer to P1



----- Latest game-history

⋮

For game history, refer to P5



----- Final game-history
(up to 20 times)

※Contents of game history

01:01/02/05 1:23

→ Based on what happened a few minutes ago before the power is switched off. What is displayed is [-----] after the game-machine is turned OFF.

→ **Historical data of 1 game (numbers of dropped prizes /numbers of jacking-up successes)**

A game is the game between the game-start and the sealing-plate closing or until the next game is played.

Taking this as an example, the prize has been jacked-up for 5 times in the limited time. 2 of them did not collide with the screen and the others are all jacked-up successfully. 1 prize can be got.

(In the case of prize-falling rapidly and continuously, the prize-falling is only counted as 1 time to include in the stopwatch.)

※The sealing-plate closing-time will change according to the setting.

If this sealing-plate is normally opened, 30 seconds after the game-ending will be recorded in the game.

After 30 seconds, if the prize falling during the normal opening of the sealing-plate is detected, it will be regarded as the historical record of the new [01/--/] game.

→ **History (the smaller the number is, the later the game-history is)**

5. Return to the main menu by pressing [BACK].

4.1.1.4 ERROR HISTORY

1. The service-panel can be seen when the right access door is opened.
2. Turn on [TEST]. The various data will be displayed and the test-mode can be entered.
3. By pressing [↑] and [↓], the arrow will point to "ERROR HISTORY". Press [SETTING] to confirm.
4. By pressing [↑] and [↓], switch to the following page.

For error history, refer to P1



----- Latest error history

For error history, refer to P2



For error history, refer to P3

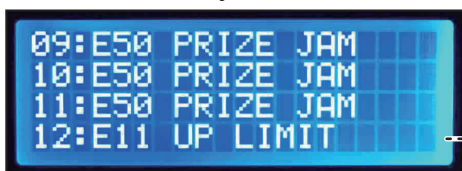

----- Final error history
(up to 12 times)

※For the error history (the error details can be checked on the error list), refer to P31-36

01:E01 COIN JAM

-----> Short for error

-----> Error

-----> History (the smaller the number is, the later the error history is)

5. Return to the main menu by pressing [BACK].

4.1.1.5 SETTING

1. The service-panel can be seen when the right access door is opened.
2. Turn on [TEST]. The various data will be displayed and the test-mode can be entered.
3. By pressing [↑] and [↓], the arrow will point to "SETTING". Press [SETTING] to confirm.
4. Select the item to be set by pressing [↑] and [↓].
5. Change the setting-value of the selected item by pressing [←] or [→].

For set item, refer to P1



| SN | Item Name | Contents | Set Range | Initial value | SEGA Recommended Setting |
|----|--------------|--|---|---------------|--------------------------|
| a | CREDIT(COIN) | <ul style="list-style-type: none"> ● Set the coins to play the game ※Player can play the CREDIT GAME after the coins are put in. ※When CREDIT (COIN) is free, CREDIT (GAME) can not be used. | 1~99: Needed coins FREE : Free mode | 1 | 1 |
| b | CREDIT(GAME) | | 1~99: Generated game | 1 | 1 |
| c | BONUS(COIN) | <ul style="list-style-type: none"> ● Set the amount of the rewards that can be got through continuous coining. ※Set BONUS (COIN) to generate a game, whether to add BONUS (GAME) setting. ※The internal settlement of the awarded game will be invalid when the game is started and before the awarded game is got. ※This item cannot be set when CREDIT (COIN) is FREE. Example: CREDIT(COIN) 1 CREDIT(GAME) 1 BONUS(COIN) 5 BONUS(GAME) 1 According to the above-said, 1 game will be played after one coin is put in. Before the game is officially started, one more game will be played after 5 coins are put in consecutively. In total, 6 games can be played. | 1~99: Needed coins | 5 | 5 |
| d | BONUS(GAME) | | 0~99: Games that generate the award (0 means there will be no award game) | 1 | 0 |

6. Select the item to be set by pressing [↑] and [↓].
7. Change the setting-value of the selected item by pressing [←] or [→].

For set item, refer to P2



For set item, refer to P3



| SN | Item Name | Contents | Set Range | Initial value | SEGA Recommended Setting |
|----|--------------|--|--|---------------|--------------------------|
| e | TIME LIMIT | <ul style="list-style-type: none"> ● Time limit for game (unit: second) ※If the jacking-up is not completed, the jacking-rod will start the jacking-up in the existing position. | OFF: No time-limit 10~990: Time-limit(unit:10 seconds) | 30 | 20 |
| f | TILT | <ul style="list-style-type: none"> ● Tilt has been detected (For TILT location, refer to the section on P33) | OFF: Ignore (no error) AUTO: After the tilting-error occurs (E02), the game will be restored after 20 seconds. MANUAL: After the tilting-error (E02) occurs, the error must be manually removed. | MANUAL | AUTO |
| g | DEMO ACTION | <ul style="list-style-type: none"> ● Set DEMO period in the standby (unit: second) | OFF: No DEMO occurs. 030~600: DEMO period (unit: 30 seconds) | 60 | 60 |
| h | DEMO SOUND | <ul style="list-style-type: none"> ● There is no sound when DEMO is performed. ※DEMO cannot be set when DEMO ACTION is OFF. | OFF: There is no sound when DEMO is performed. ON : There is the sound when DEMO is performed. BGM1: DEMO BGM1 (Christmas style) BGM2: DEMO BGM2 (Samba style) | ON | ON |
| i | MOVE SPEED | <ul style="list-style-type: none"> ● Speed setting of jacking-rod moving | FAST MIDDLE SLOW | FAST | FAST |
| j | PUSHER MODE | <ul style="list-style-type: none"> ● Setting of jacking-up | ONCE: There is only one jacking-up chance in the limited time. RETRY: There are many jacking-up chances within the limited time. | ONCE | RETRY |
| k | SHUTTER TIME | <ul style="list-style-type: none"> ● It is the time to close the sealing-plate after the game is over (unit: second) | OPEN: Sealing-plate normally-opening CLOSE: Sealing-plate normally-closing 10~990: It is the time to close the sealing-plate (in unit of 10 seconds) | 30 | 10 |
| l | PRIZE ERROR | <ul style="list-style-type: none"> ● Should the error be reported after the sealing-plate is closed? (E51) | OFF: The error shall not be reported ON: The error shall be reported | OFF | ON |

8. Select the item to be set by pressing [↑] and [↓].
9. Change the setting-value of the selected item by pressing [←] or [→].

For set item, refer to P4



For set item, refer to P5

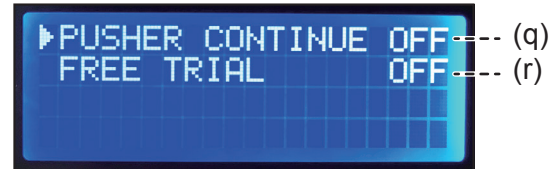

| SN | Item Name | Contents | Set Range | Initial value |
|----|-----------------|---|---|---------------|
| m | FAILURE SOUND | <ul style="list-style-type: none"> Have the sound of jacking-up failure (collision detected) and LED demo been set? | OFF: There shall be no sound and LED demo when the jacking-up fails. ON : There will be sound and LED demo when the jacking-up fails. | ON |
| n | GAME VOLUME | <ul style="list-style-type: none"> Volume in GAME BGM | 0~15(Zero is silent and 15 is maximum) | 15 |
| o | SE VOLUME | <ul style="list-style-type: none"> Volume in SE-correlated | | |
| p | ERROR VOLUME | <ul style="list-style-type: none"> Volume in ERROR alarm | | |
| q | PUSHER CONTINUE | <ul style="list-style-type: none"> According to the saved games, the action of returning to the initial position can be directly omitted after the game is over. It can directly be set whether it is jacked-up once again. ※Once this setting is set, this function will be activated once the set games are reached. Once this function is activated, this function will continue until the game becomes 0. | OFF: Every time the game is over, the game will return to the initial position. ON : After the game is over, the remaining games will directly be omitted and return to the original position. 2~10: According to the saved games, once the game is over, the action to return to the original position will be omitted (this function is used to save the game). | OFF |
| r | FREE TRIAL | <ul style="list-style-type: none"> Is the free function set (there is no need to put in the coins and the joystick can be swung)? ※If this setting is ON, DEMO action will be set according to DEMO ACTION. | OFF: There is no free function ON : There is free function | OFF |

10. To change from the original to the required, press [SETTING] or [BACK] to display the followings.

Set the interface to be changed



----- When the setting is changed with the arrow at YES: press [SETTING] to confirm.
 If the setting is not changed with the arrow at NO: press [SETTING] or [BACK] to return.
 The initial position of the arrow is at NO.

11. Return to the main menu by pressing [BACK].
 (In setting the change, return to the main menu after the change is set)

4.1.1.6 I/O TEST

1. The service-panel can be seen when the right access door is opened.
2. Turn on [TEST]. The various data will be displayed and the test-mode can be entered.
3. By pressing [↑] and [↓], the arrow will point to "I/O TEST". Press [SETTING] to confirm.
4. By pressing [↑] and [↓], switch to the following page.

For I/O test, refer to P1

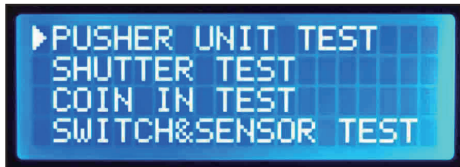

For I/O test, refer to P2



5. Return to the main menu by pressing [BACK].

4.1.1.6.1 PUSHER UNIT TEST

1. The service-panel can be seen when the right access door is opened.
2. Turn on [TEST]. The various data will be displayed and the test-mode can be entered.
3. By pressing [↑] and [↓], the arrow will point to "PUSHER UNIT TEST". Press [SETTING] to confirm.
4. Use [←] or [→] to start the action.
(If the arrow is in line 1 or line 2, the direction can be moved by using the joystick on the control panel)
(If the arrow is in line 3, the jacking-rod will move up and down by using the joystick on the control panel)
5. The jacking-rod can be changed between line 1 and line 3 by using the button on the control panel.

Jacking-rod test interface



| SN | Test content and operation | Contents |
|----|---|---|
| a | <p>● Test of left/right movement of the jacking-rod Press [→] to move to the right Press [←] to move to the left Move to all the directions by using the joystick. By pressing the button, the arrow will move to (c)</p> <p>※It will not act when moving up/down if it is not in the lower limit. If it's not in the lower limit, it shall move down first.</p> | <p>>LEFT/RIGHT --</p> <ul style="list-style-type: none"> → Detect the sensor-status when moving to the left or right (O: blocked indicator, -: bright indicator) → Right-limiter status (O: blocked indicator, -: bright indicator) → Left-limiter status (O: blocked indicator, -: bright indicator) |
| b | <p>● Test of front/back movement of jacking-rod Press [→] to move backward Press [←] to move forward Move to all the directions by using the joystick. By pressing the button, the arrow will move to (c)</p> <p>※It will not act when moving up/down if it is not in the lower limit. If it's not in the lower limit, it shall move down first.</p> | <p>>FRONT/BACK --</p> <ul style="list-style-type: none"> → Detect the sensor-status (O: blocked indicator, -: bright indicator) → Inside-limiter status (O: blocked indicator, -: bright indicator) → Front-limiter status (O: blocked indicator, -: bright indicator) |
| c | <p>● Test of up/down movement of the jacking-rod Press [→] or move up or to the right by using the joystick on the control panel. Press [←] or move down or to the left by using the joystick on the control panel. By pressing the button, the arrow will move to (a)</p> | <p>>DOWN/UP --</p> <ul style="list-style-type: none"> → Colliding-sensor status (O: blocked indicator, -: bright indicator) → Upper-limiter status (O: blocked indicator, -: bright indicator) → Lower-limiter status (O: blocked indicator, -: bright indicator) |

6. Return to I/O test by pressing [BACK].

4.1.1.6.2 SHUTTER TEST

1. Repeat steps 1-2 in 4.1.1.6.1. By pressing [↑] and [↓], the arrow will point to "SHUTTER TEST". Press [SETTING] to confirm.
2. Press [→] or move the sealing-plate upward or to the right by using the joystick on the control panel to open the sealing-plate.
3. Press [←] or move the sealing-plate downward or to the left by using the joystick on the control panel to close the sealing-plate.

Sealing-plate and prize-sensor test interface



| SN | Item Name | Contents |
|----|---------------|--|
| a | LIMIT SENSOR | <ul style="list-style-type: none"> ● Sealing-plate limit-sensor (moving position of sealing-plate motor) Starting from the left, turn off the limit sensor/turn on the limit sensor. (O: blocked indicator、 -: bright indicator) |
| b | STATUS SENSOR | <ul style="list-style-type: none"> ● Sealing-plate status sensor (actual status of the sealing-plate) Starting from the left, turn off the sensor/turn on the sensor. (O: blocked indicator、 -: bright indicator) |
| c | PRIZE SENSOR | <ul style="list-style-type: none"> ● Prize-sensor (O: Prize detected、 -: No prize detected) |

4. Return to I/O test by pressing [BACK].

4.1.1.6.3 COIN IN TEST

1. Repeat steps 1-2 in 4.1.1.6.1. By pressing [↑] and [↓], the arrow will point to "COIN IN TEST". Press [SETTING] to confirm.
2. When LEFTWARD is pressed, the coin-acceptor acts (**this step is only suitable for use with Lock feet**)

Test of coin-acceptor



Sensor at the time of coining
(O: ON、 -: OFF), Detected coins

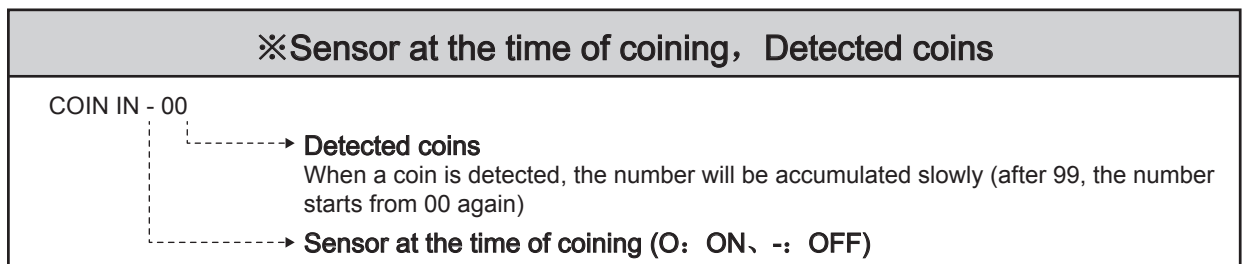

3. Return to I/O test by pressing [BACK].

4.1.1.6.4 SWITCH&SENSOR TEST

1. Repeat steps 1-2 in 4.1.1.6.1. By pressing [↑] and [↓], the arrow will point to "SWITCH&SENSOR TEST". Press [SETTING] to confirm.
2. When a button is pressed, it is displayed in shape of (O: ON、 -: OFF).

Button/sensor test interface



| SN | Item Name | Contents |
|----|--------------|--|
| a | SWITCH | <ul style="list-style-type: none"> ● Status of service-panel button and prize count button The buttons from the left are: TEST SW/UP/RIGHT/DOWN/LEFT/BACK/SETTING/SERVICE/PRIZE COUNT BUTTON (O: ON、 -: OFF) |
| b | JOYSTICK | <ul style="list-style-type: none"> ● Joystick status on the control panel The buttons from the left are: UP/DOWN/LEFT/RIGHT Jacking-rod status (O: ON、 -: OFF) |
| c | START BUTTON | <ul style="list-style-type: none"> ● Button status on the control panel (O: ON、 -: OFF) ※The indicator on the button will be on when the button is pressed. |
| d | TILT | <ul style="list-style-type: none"> ● Antitilt status (O: ON、 -: OFF) |

3. Return to I/O test by pressing [BACK] for a long time.

4.1.1.6.5 LED TEST

1. Repeat steps 1-2 in 4.1.1.6.1. By pressing [↑] and [↓], the arrow will point to "LED TEST". Press [SETTING] to confirm.
2. By pressing [↑] and [↓], select different Nos.; different Nos. will light up different color effects.

LED test



| LED SN | Item name (part) |
|--------|---|
| 00 | ALL OFF |
| 01 | Button (Jacking-up) |
| 02 | Front-frame LED (right) 、Prize outlet (red) |
| 03 | Front-frame LED (right) 、Prize outlet (green) |
| 04 | Front-frame LED (right) 、Prize outlet (blue) |
| 05 | Front-frame LED (right) 、Prize outlet (white) |
| 06 | Front-frame LED (left) 、Control-panel LED (red) |
| 07 | Front-frame LED (left) 、Control-panel LED (green) |
| 08 | Front-frame LED (left) 、Control-panel LED (blue) |
| 09 | Front-frame LED (left) 、Control-panel LED (white) |

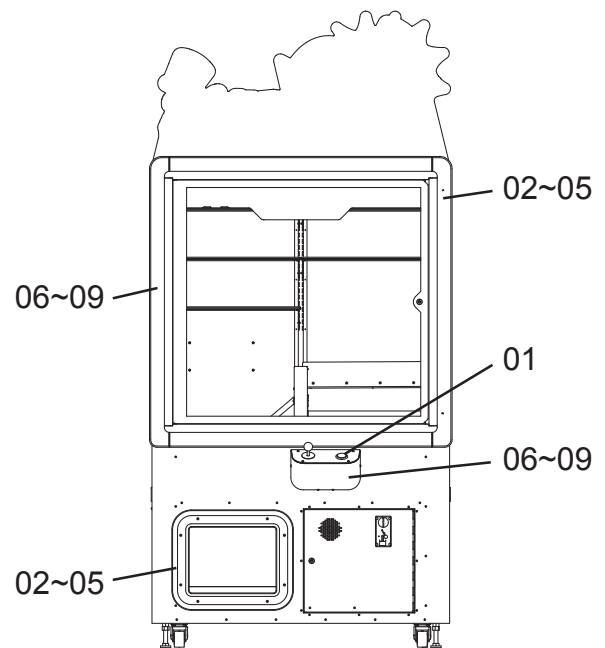

3. Return to I/O test by pressing [BACK].

4.1.1.6.6 7SEG TEST

1. Repeat steps 1-2 in 4.1.1.6.1. By pressing [↑] and [↓], the arrow will point to “7SEG TEST”. Press [SETTING] to confirm.
2. During the display of this interface, the lamps on the digital board will automatically be on in the order marked below.

Digital-board test



Order of lamp-lighting on digital board

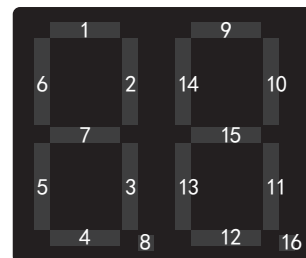

3. Return to I/O test by pressing [BACK].

4.1.1.6.7 SOUND TEST

1. Repeat steps 1-2 in 4.1.1.6.1. By pressing [↑] and [↓], the arrow will point to “SOUND TEST”. Press [SETTING] to confirm.
2. Select the sound to be played and play the sound by pressing [↑] and [↓].
3. By pressing [SETTING] and the sound will be replayed at this time.

Sound test



Replayed sound

※For the sound SN, refer to the sound list on P37 “4.4”

4. Return to I/O test by pressing [BACK].

4.1.1.6.8 AGING TEST

1. Repeat steps 1-2 in 4.1.1.6.1. By pressing [↑] and [↓], the arrow will point to "AGING TEST". Press [SETTING] to confirm.
2. Start the aging-test by pressing [SETTING].
3. During the aging-test, press [SETTING] to stop the aging-test.

Aging-test



| SN | Item Name | Contents |
|----|---|--|
| a | Aging-test | <ul style="list-style-type: none"> ● Display the current aging-test. (OFF: stop the aging-test, ON: start the aging-test) |
| b | Numbers of detected prize-dropping / numbers of played games | <ul style="list-style-type: none"> ● The left is the numbers of detected prize-dropping. The right is the numbers of played games. ※9999 times can be displayed at most. When 9999 times are exceeded, the stopwatch will automatically stop. This value will always be displayed at the aging test interface. |
| c | Numbers of failures caused by collision/numbers of jacking-up | <ul style="list-style-type: none"> ● The left is the numbers of failures caused by the collision. The right is the numbers of jacking-up. ※9999 times can be displayed at most. When 9999 times are exceeded, the stopwatch will automatically stop. This value will always be displayed at the aging test interface. |
| d | Error display | <ul style="list-style-type: none"> ● Once an error occurs, the error name is displayed here (For details, refer to Error List on P31-36) Press [SETTING] to stop the aging test and the error will disappear. |

4. Return to I/O test by pressing [BACK].

4.1.1.7 DATA CLEAR

1. Repeat steps 1-2 in 4.1.1.6.1. By pressing [↑] and [↓], the arrow will point to "DATA CLEAR". Press [SETTING] to confirm.
2. Select the items to be initialized by the arrow by pressing [↑] and [↓].
3. Keep on pressing [SETTING] to make sure it starts to display the countdown.
Press it for 5 seconds to clear the data.

For data-clearing



| SN | Item Name | Contents | It's possible to use it |
|----|--------------|--|--|
| a | ALL CLEAR | <ul style="list-style-type: none"> ● Clear all the data and restore the factory defaults. | When all are restored to factory settings. |
| b | METER CLEAR | <ul style="list-style-type: none"> ● All the data except the settings are cleared. | All the settings are kept to the same state and others need to be reset. |
| c | CREDIT CLEAR | <ul style="list-style-type: none"> ● Clear the remaining games and games currently in play. | Games saved there or games to be invalid. |

4. Return to the main menu by pressing [BACK].

4.1.1.8 ROM VERSION

1. Repeat steps 1-2 in 4.1.1.6.1. By pressing [↑] and [↓], the arrow will point to "ROM VERSION". Press [SETTING] to confirm.
2. By pressing [↑] and [↓], switch to the following page.

ROM version confirmation interface

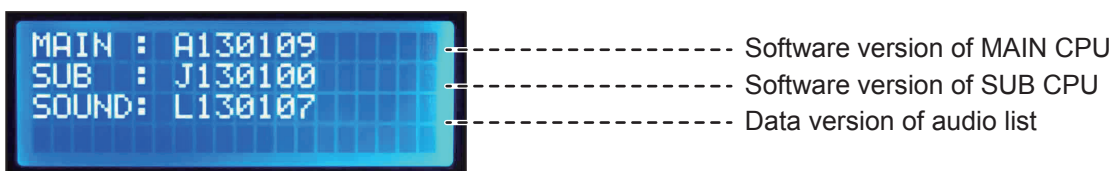

3. Return to the main menu by pressing [BACK].

4.2 Error Display

When an error occurs, "E-" and corresponding error is displayed alternately on the digital board.

Meanwhile, the error is displayed on LCD and ERROR HISTORY will be saved.

Example: When error 1 occurs



When there are 2 errors and the player can't tell which one is correct, the digital display-board will alternate between "E-" and error number.

Meanwhile, the error is displayed on LCD and ERROR HISTORY will be saved.

Example: When the error is E22 or E20

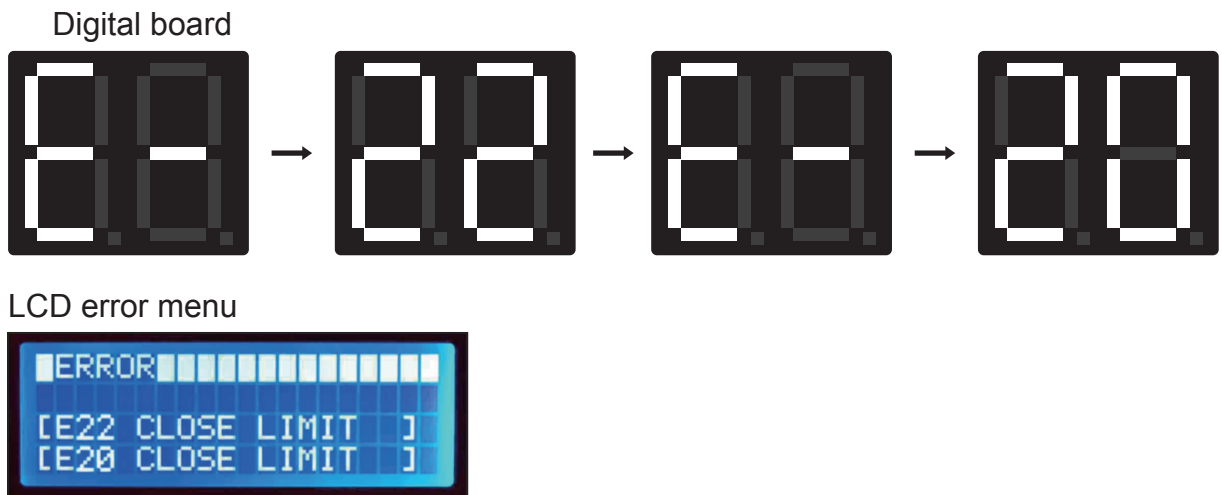

4.3 Error List

【Way to remove the error】

First of all, the error cause shall be found. ON to OFF of [TEST], press OFF to remove the error.



| Error Code | Error Meaning | LCD Display | Causes | Way to remove |
|------------|---|--------------------|--|--|
| E01 | COIN JAM ERROR | E01 COIN JAM | When the coin-sensor of the coin-acceptor is ON for two seconds, it cannot be turned OFF. | Take out the coins stuck in the coin-acceptor. |
| E02 | TILT | E02 TILT | Detected to tilt (The frame has been shaken) | The solution is to change [TILT]setting. In auto mode, the game will be automatically restored after sounding for 20 seconds. In manual mode, the game will not be automatically restored and the error shall be remedied in order. This error will not occur if set to OFF. ※if the game is interrupted due to this error, the game will be directly cancelled and the game cannot be continued after restarting. |
| E10 | Jacking-rod Lower limit-sensor error | E10 DOWN LIMIT | The lower limit-sensor does not sense within 6 seconds when the jacking-rod is about to move downward. | It may be the moving-up/down motor fault or lower limit-sensor fault. |
| E11 | Jacking-rod Upper limit-sensor error | E11 UP LIMIT | The upper limit-sensor or colliding-sensor do not sense within 6 seconds when the jacking-rod is moving upward. | 1. It may be the moving-up/down motor fault or upper limit-sensor fault. 2. It may be that the screw on the moving-up/down motor is screwed too tightly to result in too little pressure on the wheel and the jacking-rod cannot rise.(please refer to the sections on P52 "5.2.21" for how to adjust the jacking-rod). 3. There may be oil-slick on the jacking-rod, which needs to be cleaned. 4. Check whether the jacking-rod is blocked when rising. |
| E12 | Jacking-rod Colliding sensor error | E12 PUSHER BUMP | The colliding sensor is detected during which the jacking-rod is moving upward. | The colliding sensor malfunctions. |
| E20 | Jacking-rod Left limit-sensor error | E20 LEFT LIMIT | The left limit-sensor does not sense within 10 seconds when the jacking-rod is moving to the left. | The left limit-sensor malfunctions. |
| E21 | Jacking-rod Right limit-sensor error | E21 RIGHT LIMIT | The right limit-sensor does not sense within 10 seconds when the jacking-rod is moving to the left. | The right limit-sensor malfunctions. |
| E22 | Jacking-rod Moving-left/right -sensor error | E22 L/R SPIN | When the jacking-rod moves to the right or left, the moving-left/right-sensor or the left/right limit-sensor does not sense within 1 second. | The moving-left/right motor or the moving-left/right-sensor or left/right limit-sensor malfunction. |
| E30 | Jacking-rod Front limit-sensor error | E30 FRONT LIMIT | The front limit-sensor does not sense within 8 seconds when the jacking-rod moves forward. | The front limit-sensor malfunctions. |

| Error Code | Error Meaning | LCD Display | Causes | Way to remove |
|------------|---|----------------|---|---|
| E31 | Jacking-rod Bank limit-sensor error | E31 BACK LIMIT | The bank limit-sensor does not sense within 8 seconds when the jacking-rod moves backward. | The bank limit-sensor malfunctions. |
| E32 | Jacking-rod Moving-forward/backward -sensor error | E32 F/B SPIN | When the jacking-rod moves forward, the moving-forward/ backward sensor or limit-sensor do not sense within 1 second. | The moving-forward/backward motor, the moving-forward/ backward sensor and limit sensor malfunction. |

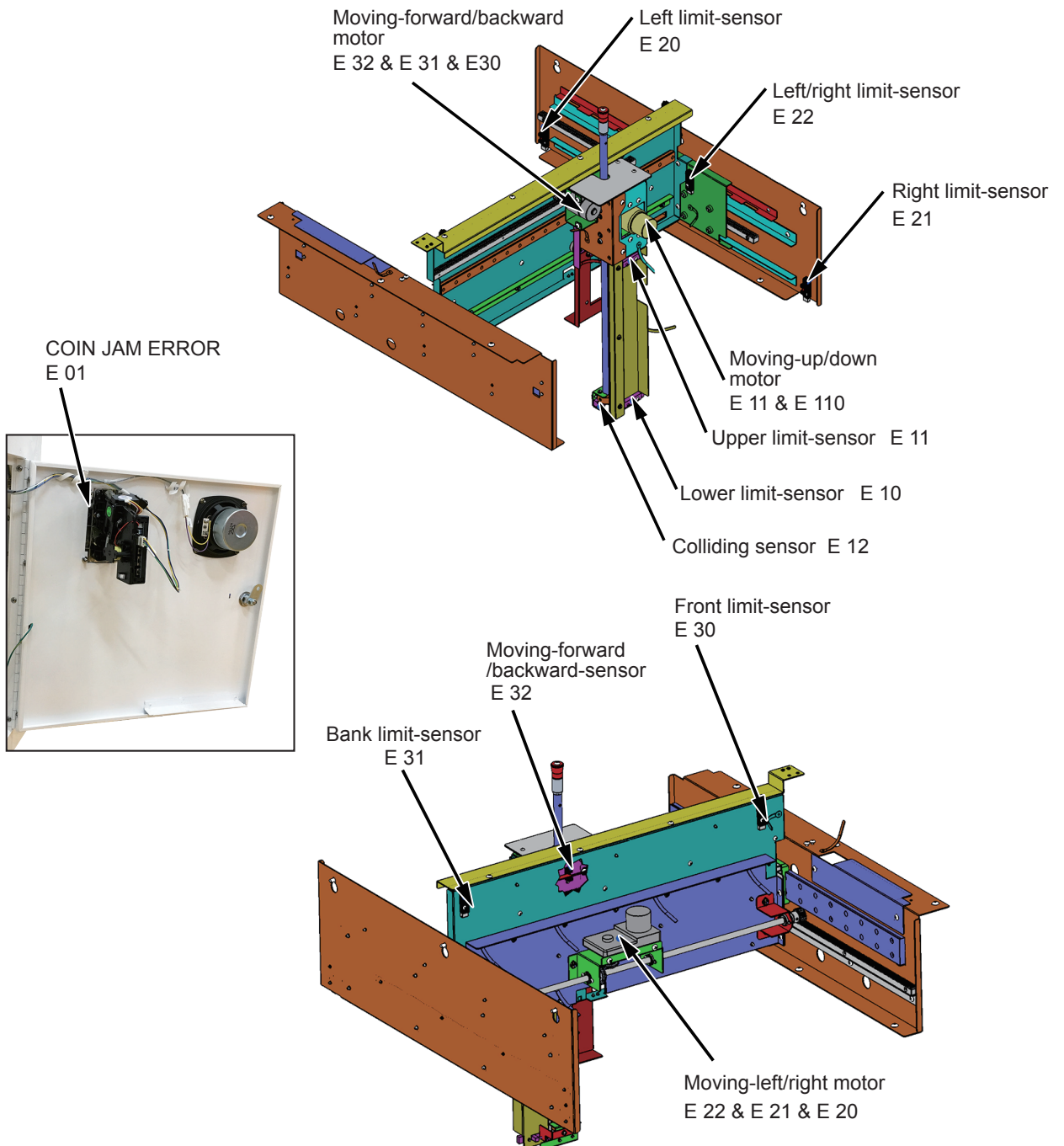

| Error Code | Error Meaning | LCD Display | Causes | Way to remove |
|------------|---|-----------------|---|---|
| E40 | Sealing-plate (motor side) The opening limit-sensor gives an error | E40 OPEN LIMIT | When the sealing-plate is opened, the opening limit-sensor does not sense within 5 seconds. | The opening limit-sensor malfunctions. |
| E41 | Sealing-plate (motor side) The closing limit-sensor gives an error | E41 CLOSE LIMIT | When the sealing-plate is closed, the closing limit-sensor does not sense within 5 seconds. | The closing limit-sensor malfunctions. |
| E42 | Sealing-plate The opening-sensor gives an error | E42 OPEN JAM | It has nothing to do with the opening limiter and the opening sensor does not sense within 2 seconds. | 1.A prize is blocked on the opening-side of the sealing-plate because the sealing-plate is not fully opened. 2.It is possible that the door-spring may come loose (please refer to "5.2.31" on P57 for how to adjust the door-spring) |
| E43 | Sealing-plate The closing limit-sensor gives an error | E43 CLOSE JAM | It has nothing to do with the closing limiter and the closing-sensor does not sense within 2 seconds. | 1.A prize is blocked on the closing-side of the sealing-plate because the sealing-plate is not fully closed. 2.It is possible that the door-spring may come loose (please refer to "5.2.31" on P57 for how to adjust the door-spring) |
| E50 | The prize-block gives an error | E50 PRIZE JAM | If the prize falls off, the sensor will be on for 1 second without turning off. | 1.Make sure whether the prize is blocked near the sensor. 2.The optical-eye box is out of order. (please refer to section on P36 for how to calibrate the optical-eye box) ※If the blocked-prize is about to be given to the player, press the prize count button to hop the stopwatch automatically after the error is remedied. |
| E51 | The prize-error gives an error | E51 PRIZE FALL | While not in the game (the sealing-plate is closed), the prize-dropping is sensed by the sensor. | Check whether there is an inappropriate act or a prize-dropping fault. |
| E97 | Communication error | E97 SUBCPU COMM | There is a communication error between CPU and SUB CPU on the main board. | If it is not improved when the power-OFF is changed to power-ON, replace the main board. |
| E98 | Low battery | E98 BATTERY LOW | The battery on the main board is detected in a low voltage. | Please replace the battery on the main board. ※This error can only be detected at startup. After a certain period of time, press the button on the control panel and it will be automatically removed. |
| E99 | Version error | E99 PROGRAM VER | The version of MAIN CPU is inconsistent with that of SUB CPU and SOUND ROM. | The wrong program is loaded to the main board. |

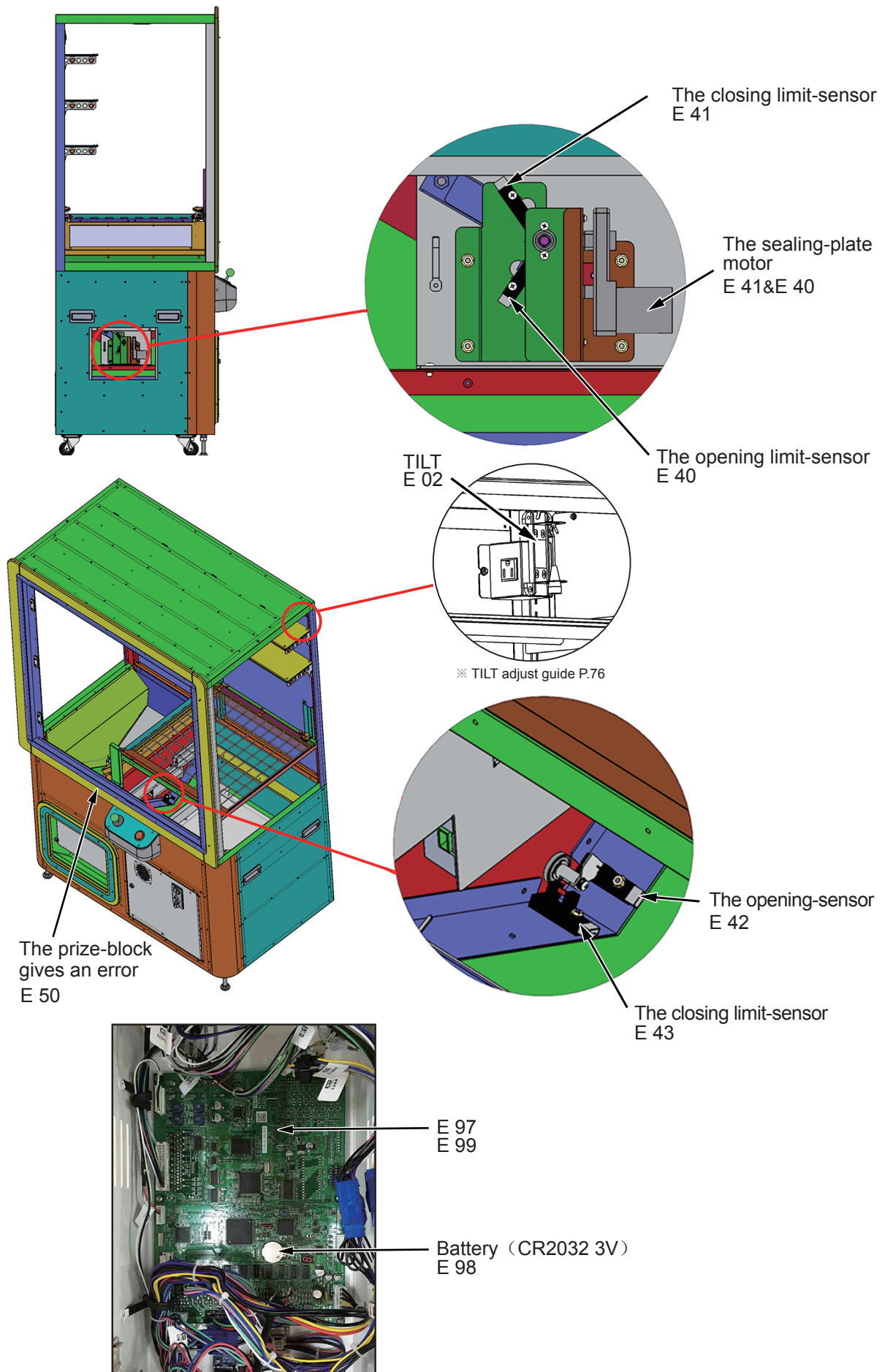

【Calibrating procedure of optical-eye box】

This game-machine is provided with 3 optical-eye boxes. They are A optical-eye box, B optical-eye box and C optical-eye box, as shown in the right figure. In the event that no prize is detected or E50 error is given, A, B and C optical-eye boxes can be calibrated separately. When calibrating, the optical-eye box with the green indicator must be calibrated first. If no optical-eye box with the green indicator is found, one optical-eye box can be arbitrarily selected for calibration.

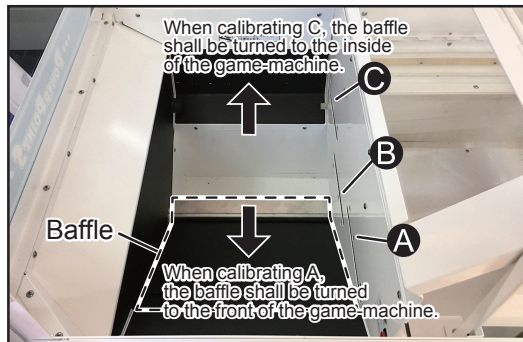

Note: When calibrating A, manually turn the baffle towards the front of the game-machine. When calibrating B, there is no requirement for baffle. When calibrating C, manually turn the baffle towards the inside of the game-machine.

Calibrating procedure

1. Press the button of "1" Calibration Port for 3-5 seconds with the iron-bar and release the button when "2" indicator turns red. At this moment, the optical-eye box will enter into automatic calibration and the red indicator will begin flashing.
2. When the red indicator stops flashing (4-8 seconds), the calibration is completed. If the red indicator is flashing continuously, it can be judged as an optical-eye box fault.

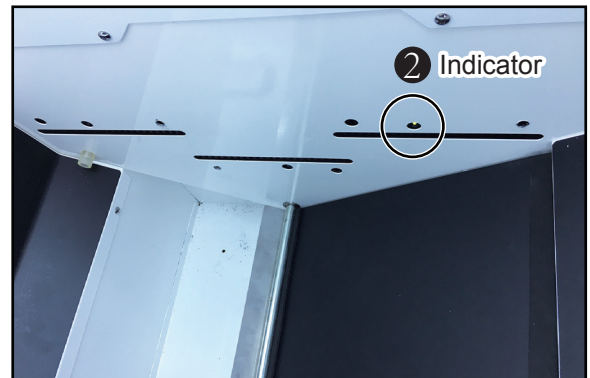
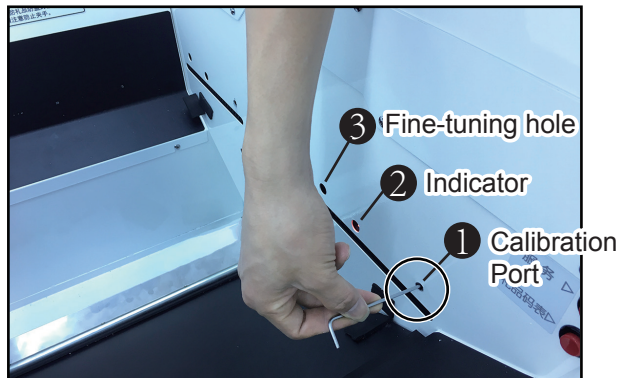

3. After the calibration of the three photocell boxes of ABC is completed, put white paper or 90% reflective paper on the opposite side of each photocell box of ABC. If the corresponding photocell box status indicator is green, the light will be off after removing it. That is, the calibration is qualified.
4. If the green light is not displayed on the opposite side of the photocell box, you can calibrate the photocell box separately. If it still does not work, use a small Phillips screwdriver (diameter 3mm) to insert the 3 fine-tuning holes to adjust the detection distance. (Rotate clockwise, the detection distance is long. Rotate counterclockwise, the detection distance is short.) Until the green light is blocked with white paper or 90% reflective paper, the light goes out.

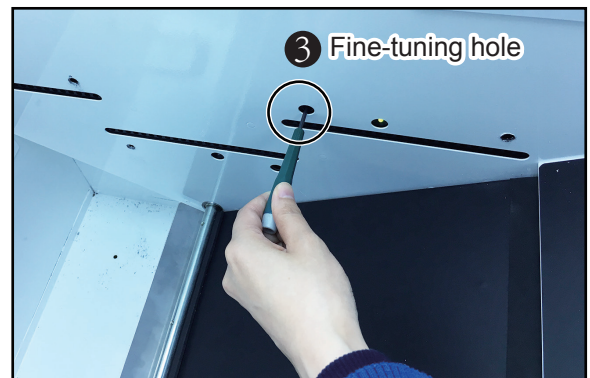

If the indicator cannot turn green after adjustment, the corresponding optical-eye box shall be replaced (please refer to section on P49 for replacement of optical-eye box).

4.4 Sound List

| SN | Category | Item Name | Usage | Conditions of usage |
|----|----------|--|--|---------------------|
| 1 | BGM | Game BGM | Play BGM while playing | LOOP |
| 2 | JINGLE | Played music for getting the prize successfully | Played cheers for getting the prize successfully | |
| 3 | JINGLE | Jacking-up failure (collision) sound | Regreted sound for not getting the prize | |
| 4 | SE | Longitudinal-moving sound of jacking-rod (upper) | sound of the jacking-rod moving | |
| 5 | SE | Longitudinal-moving sound of jacking-rod (lower) | sound of the jacking-rod moving | |
| 6 | SE | Sound of hitting the upper limiter | Jacking-rod sound of reaching the upper limiter | |
| 7 | SE | Error sound | Error-warning sound | |
| 8 | SE | TILT error-sound | TILT error-warning sound | |
| 9 | SE | Countdown sound | Countdown sound nearing the time limit (countdown when the remaining time is 10 seconds) | |
| 10 | SE | Time-out sound | Sound reaching the time limit (it will sound when the remaining time is 0) | |
| 11 | SE | Coining-sound | Coining-sound (when not playing the game) | |
| 12 | SE | The sound playing the game | Coining-sound (when not playing the game) | |
| 13 | SE | ENTER | Button operation sound for testing | |
| 14 | SE | BACK | Button operation sound for testing | |
| 15 | SE | Up and down, left and right | Button operation sound for testing | |
| 16 | SE | Sensor-ON | Sensor-ON sound in the sensor test | |
| 17 | SE | Sensor-OFF | Sensor-OFF sound in the sensor test | |
| 18 | BGM | DEMO BGM1 (Christmas style) | Play BGM before playing the game | |
| 19 | BGM | DEMO BGM2 (Samba style) | Play BGM before playing the game | |

4.5 Main-board DIP SW setting

| DIP SW | Function | OFF | ON |
|--------|--|-------------------------------|------------------------------|
| 1 | Used in OFF | OFF | |
| 2 | Used in OFF | OFF | |
| 3 | Used in OFF | OFF | |
| 4 | Used in OFF | OFF | |
| 5 | Used in OFF | OFF | |
| 6 | Displayed contents on the digital board at the time of coining | Displaying the existing coins | Displaying the existing game |
| 7 | Used in OFF | OFF | |
| 8 | Used in OFF | OFF | |

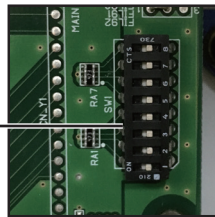
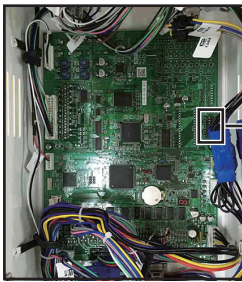

DIP SW

- All are OFF by default
- The settings are only valid when the power is turned on. (the changes are invalid in startup)

4.6 Displayed contents on the digital board at the time of coining

When the coins (CREDIT COIN) are more than 2, the stored coins will be displayed before playing the game. The game will be displayed if the game is played. It's the function of which one to be displayed first.

When being turned OFF, the coins shall be displayed first.

When being turned ON, the game shall be displayed first.

■ **When being turned OFF, take 3 coins for 1 game as example.**

"01" begins to flash when the 1st coin is put in.

↓
"02" begins to flash when the 2nd coin is put in.

↓
After "03" begins to flash when the 3rd coin is put in, switch to normally-lighting "01" (since the coins are not saved, only the game is displayed)

↓
Display "01" when the 1st coin is put in (the saved coins are displayed first)

↓
Display "02" when the 2nd coin is put in (the saved coins are displayed first)

↓
After "03" begins to flash when the 3rd coin is put in, switch to normally-lighting "02" (since the coins are not saved, only the game is displayed)

↓
...

■ **When being turned ON, take 3 coins for 1 game as example.**

"01" begins to flash when the 1st coin is put in.

↓
"02" begins to flash when the 2nd coin is put in.

↓
After "03" begins to flash when the 3rd coin is put in, switch to normally-lighting "01"

↓
On this basis, when the 1st coin is put in, the normally-lighting "01" is displayed (the game is displayed first)

↓
On this basis, when the 2nd coin is put in, the normally-lighting "01" is displayed (the game is displayed first)

↓
On this basis, when the 3rd coin is put in, the normally-lighting "02" is switched to.

↓
...

5. Maintenance and Service

5.1 Maintenance and service

Even though the machine works normally for a long time, the fault will occur. Therefore, please perform routine check and maintenance concerning the following to ensure a long-term use.

■ External Inspection

- Stick “Warning” stickers correctly, keep it legible.
- Firmly tighten the bolt for each adjuster.
- Tighten screws for speaker assembly.
- Tighten the signboard firmly.
- Check if the screws fixing the parts loose.
- Check if the connectors loose or missing.

■ Operation Inspection (With power on)

- Sound is normally emitted from the speakers or not.
- Fluorescent lamps and button lamps light up or not
- Coin acceptor works properly or not.
- Lifting and falling devices work properly or not.
- YZ sensor works properly or not.

After completing all the checks, operate the game again and check the above items with full care!

■ Servicing (conducted by a technician only)

- Cut off the main power supply to avoid injury or electric shock when performing maintenance.
- Please contact our service center when performing any work that is not specified in this Manual, and follow the instruction provided by the service center.
- For consumables and spare parts (including screws), please use products specified by Wahlap Technology.
- Even though the main power is cut off, there is still high temperature and high pressure in the power board and the monitor. The person will be burnt or get an electric shock if he touches such parts. Please pay full attention to avoid contact.
- Be sure to cut off the main power when you alter a spare part or unplug a connector.
- The jacking-rod should be cleaned regularly to avoid oil-slick.

5.2 Part Replacement

5.2.1 Change LED with casing

1. Open the acrylic door with the key, untie the cable ties and pull out the terminal corresponding to the damaged LED.
2. Remove shelled LEDs from 2 card-slots and reinstall in a reverse order after replacing.

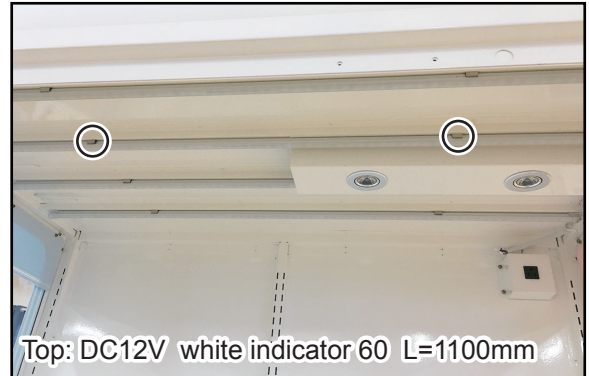

5.2.2 Replacement of ceiling lamp

1. Use the key to open the acrylic door and pull out the ceiling lamp. (be careful of fingers)
2. Pull out the corresponding terminal and remove the ceiling lamp, reinstall in a reverse order after replacing.

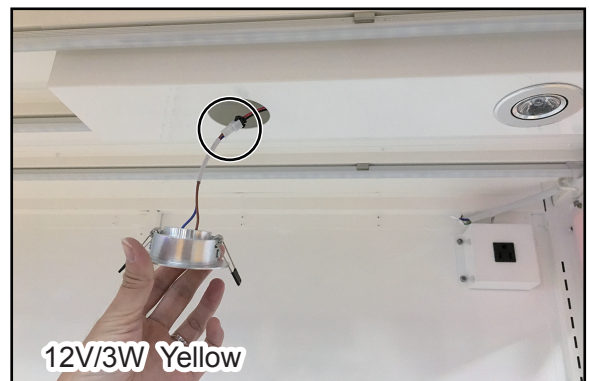

5.2.3 Change door-frame acrylic soft-lamp-bar

1. Assess the damaged position of soft light-bars on the door-frame and there are 2 soft light-bars, which are on the left-side and right-side.
2. If the soft light-bar on the right side is damaged, use the key to open the acrylic door, remove 2 nuts that fix the iron-sheet and remove the iron-sheet.

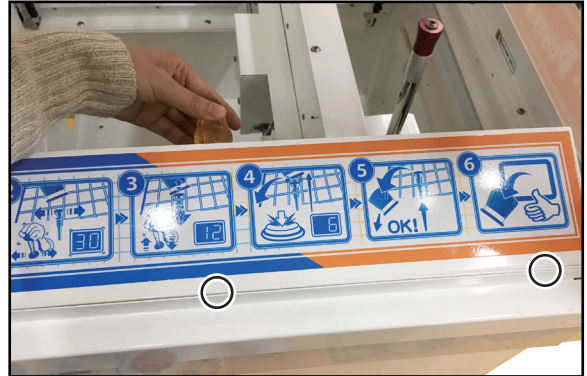

3. Press 2 red buttons to move the net down. (if the soft light-bar on the left side is damaged, step 3 and 4 are not needed)
4. Remove 2 screws on the right side to fix the net pillar and remove the screen pillar.

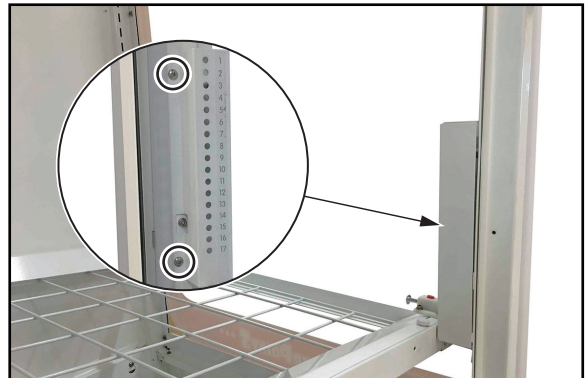
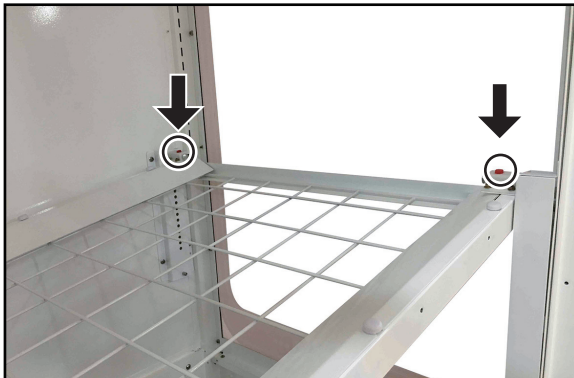

5. Remove the screws and nuts that fix the mould-weight on the door frame.
6. Pull out the corresponding terminal.

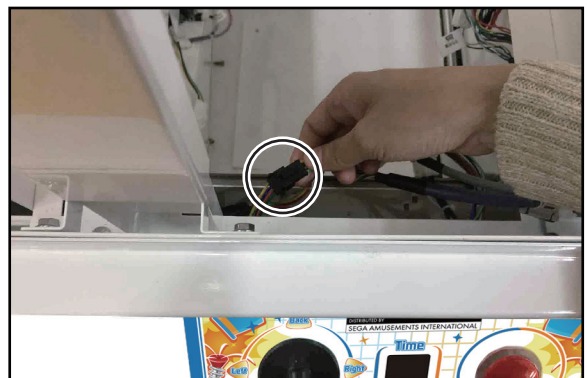
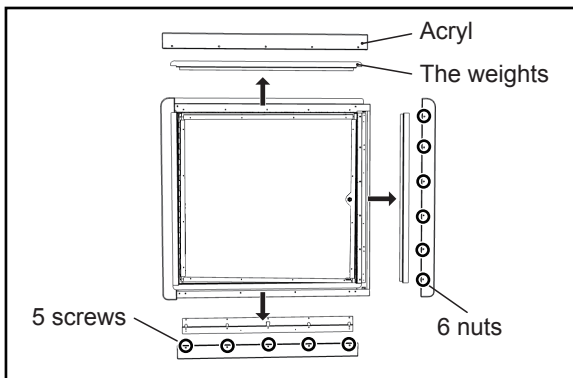

7. Remove the soft light-bar, reinstall in a reverse order after replacing.

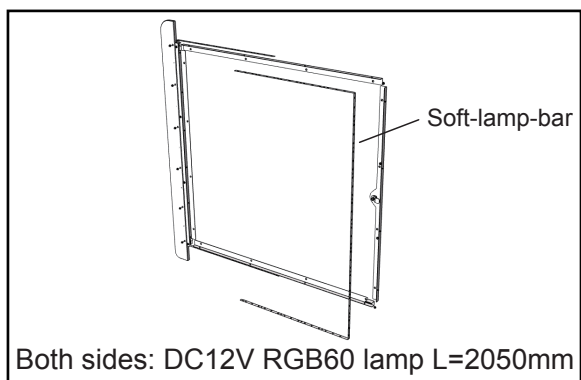

5.2.4 Change prize-outlet soft-lamp-bar

1. Remove 8 screws that fix the mould-weight at the prize outlet and remove the mould-weight and acryl at the prize outlet.
2. Pull out the corresponding terminal, Remove the soft light-bar, reinstall in a reverse order after replacing.

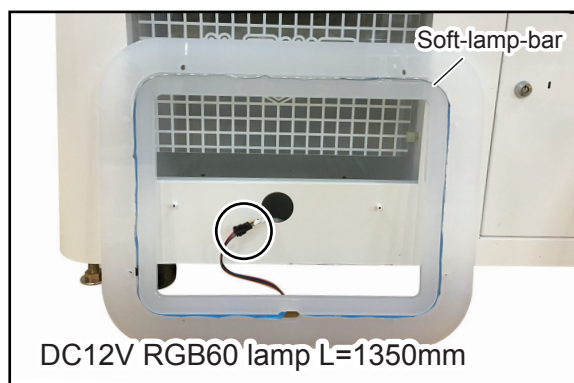

5.2.5 Change control-panel soft-lamp-bar

1. Turn off the game-machine. Open the acrylic door with the key, remove the screen and 2 screws that fix the service-hatch cover-plate and remove the service-hatch cover-plate.
2. Remove 4 screws that fix the control panel and remove the control panel.

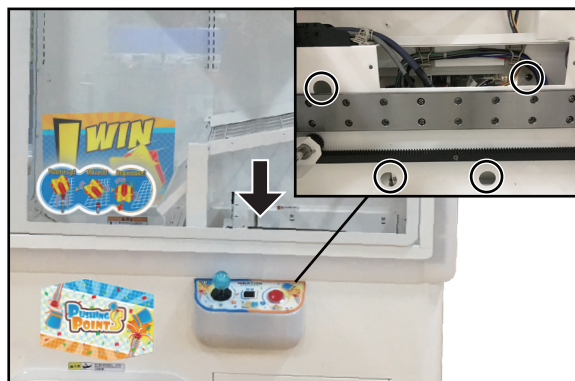
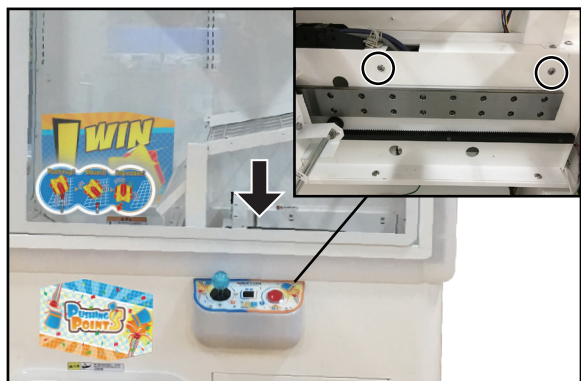

3. Use the slot-type screwdriver to fix the joystick. At the same time, rotate the joystick-ball counterclockwise and take out the black plastic sheeting.
4. Remove 4 screws to fix the acryl.

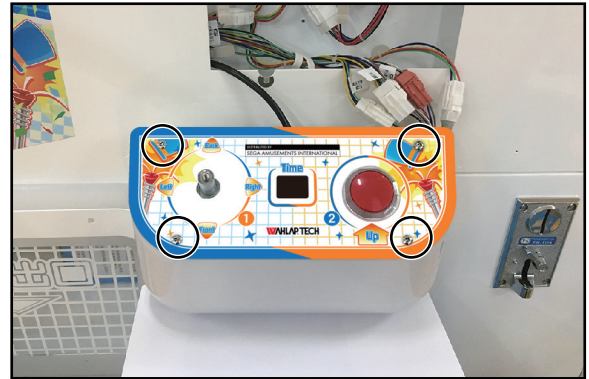
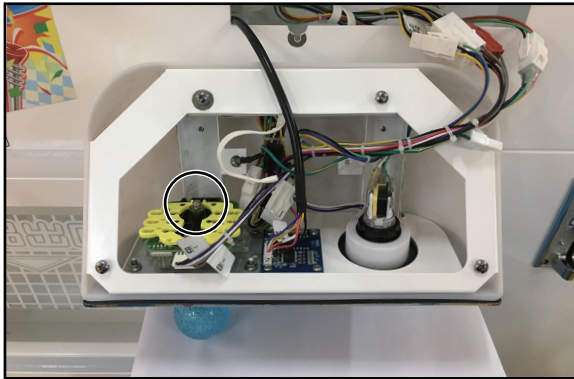

5. Turn the acryl on the other-side, pull out the corresponding terminal and remove the acryl.
6. Remove 4 screws that fix the control-panel plastic-cover and remove the control-panel plastic-cover.

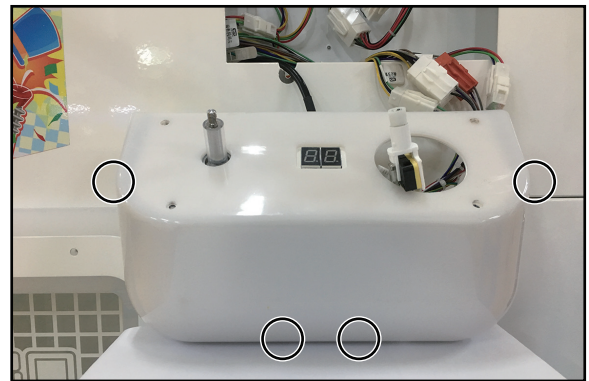
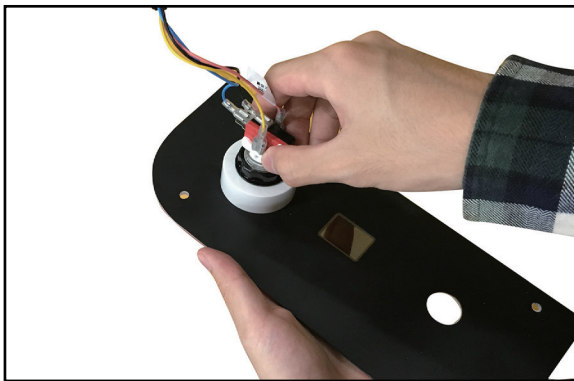

7. Cut off the cable-tie, pull out the corresponding terminal and remove the soft light-bar, reinstall in a reverse order after replacing.

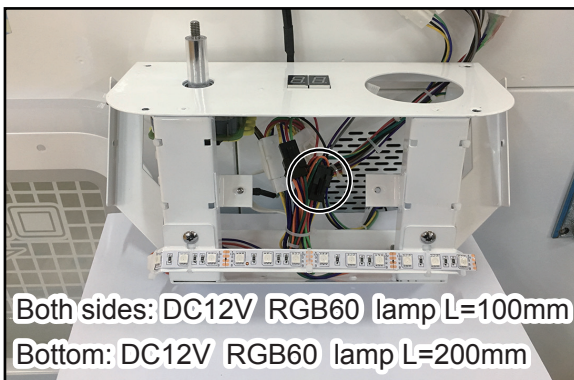

5.2.6 Change control-panel joystick

1. Turn off the game-machine. Open the acrylic door with the key, remove the screen and 2 screws that fix the service-hatch cover-plate and remove the service-hatch cover-plate.
2. Remove 4 screws that fix the control panel and remove the control panel.

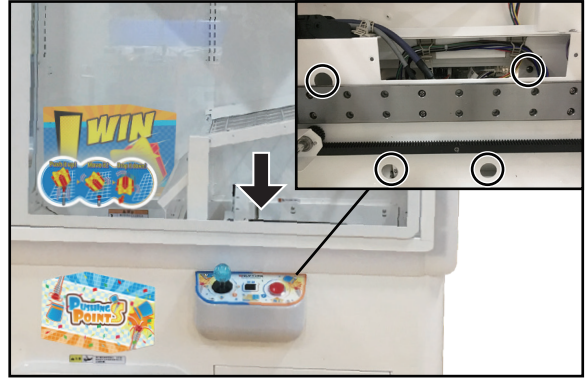
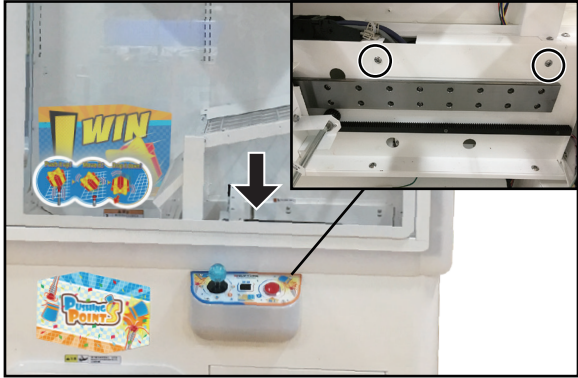

3. Use the slot-type screwdriver to fix the joystick. At the same time, rotate the joystick-ball counterclockwise and take out the black plastic sheeting.
4. Remove 4 screws to fix the acryl.

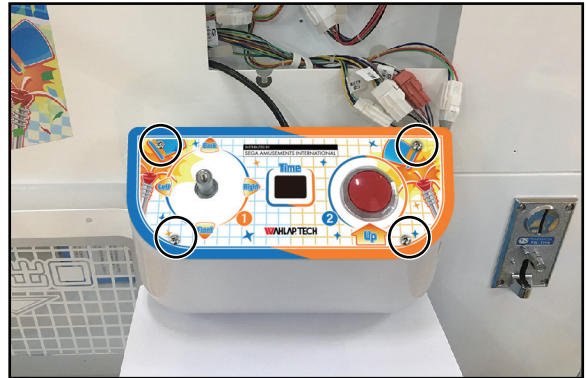
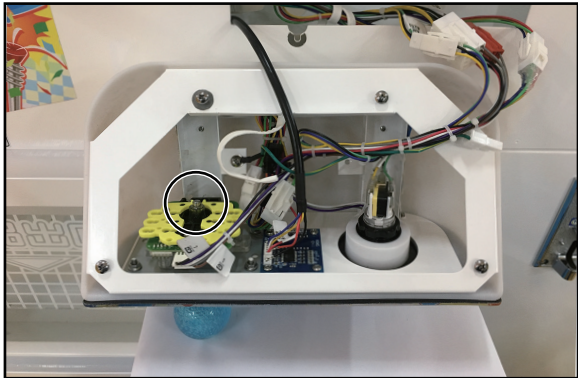

5. Turn the acryl on the other-side, pull out the corresponding terminal and remove the acryl.
6. Remove 4 screws that fix the control-panel plastic-cover and remove the control-panel plastic-cover.

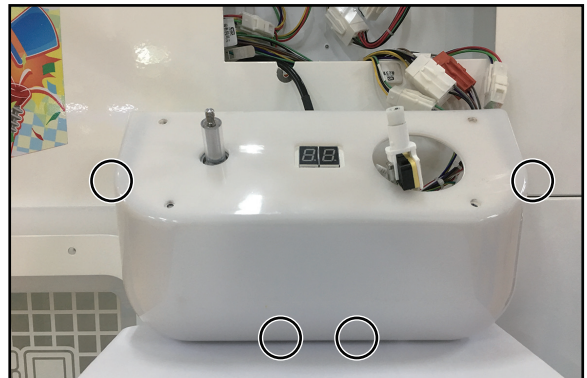

7. Remove 4 screws to fix the joystick, cut off the cable tie, pull out the corresponding terminal and remove the joystick, reinstall in a reverse order after replacing.

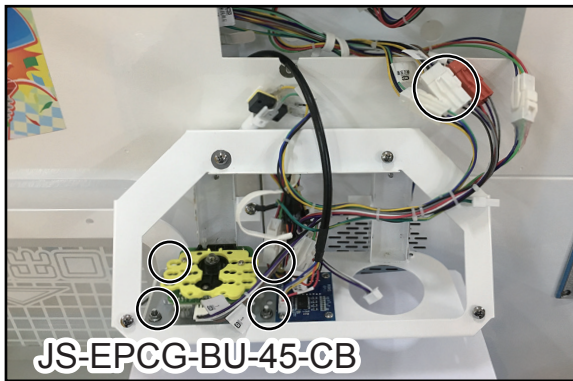

5.2.7 Change control-panel button

1. Remove 4 screws to fix the acryl.
2. Cut off the cable tie, pull out the corresponding terminal and remove the button, reinstall in a reverse order after replacing.



5.2.8 Change control-panel digital-board (7SEG)

1. Turn off the game-machine. Open the acrylic door with the key, remove the screen and 2 screws that fix the service-hatch cover-plate and remove the service-hatch cover-plate.
2. Remove 4 screws that fix the control panel and remove the control panel.

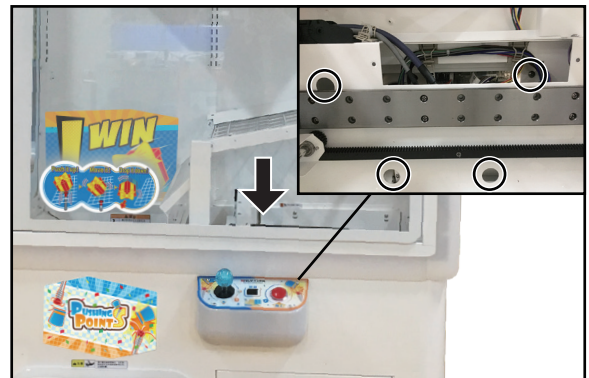
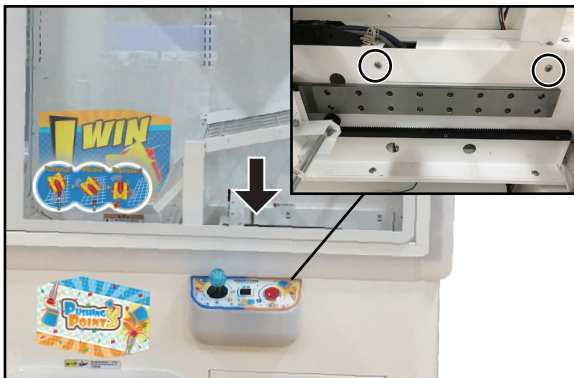

3. Remove 4 screws that fix the digital display board, cut off the cable tie, pull out the corresponding terminal and remove the digital display board, reinstall in a reverse order after replacing.

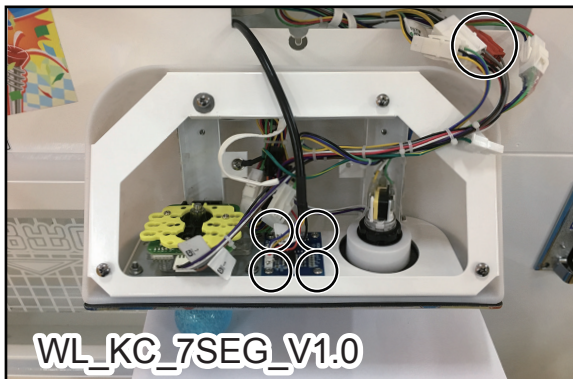

5.2.9 Replacement of left/right sensors

1. Turn off the game-machine and remove the screen. There are 2 sensors on the horizontal guide-rail.
2. Remove the screw to fix the sensor, pull out the corresponding terminal and remove the sensor, reinstall in a reverse order after replacing.



5.2.10 Replacement of horizontally-moving sensors

1. Turn off the game-machine. Open the acrylic door with the key, remove the screen, there is 1 sensor on the horizontal roller-plate.
2. Remove the screw to fix the sensor, pull out the corresponding terminal and remove the sensor, reinstall in a reverse order after replacing.



5.2.11 Replacement of front/rear sensors

1. Turn off the game-machine. Open the acrylic door with the key, remove the screen,there are 2 sensors on the longitudinal rail.
2. Remove the screw to fix the sensor, pull out the corresponding terminal and remove the sensor, reinstall in a reverse order after replacing.

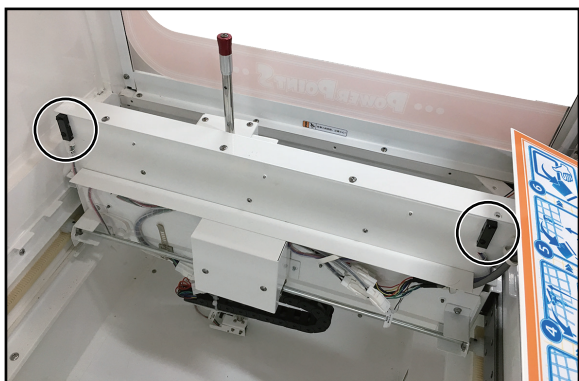

5.2.12 Replacement of longitudinall-moving sensors

1. Turn off the game-machine. Open the acrylic door with the key, remove the screen,remove 3 screws to fix the longitudinal slider fixing-iron.
2. Remove the screw to fix the sensor, pull out the corresponding terminal and remove the sensor, reinstall in a reverse order after replacing.

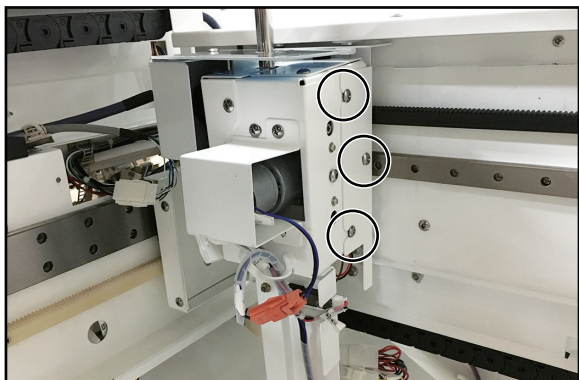

5.2.13 Replacement of upper/lower limit sensors

1. Turn off the game-machine. Open the acrylic door with the key, remove the screen,there are 2 sensors on the lifting raceway.
2. Remove the screw to fix the sensor, pull out the corresponding terminal and remove the sensor, reinstall in a reverse order after replacing.

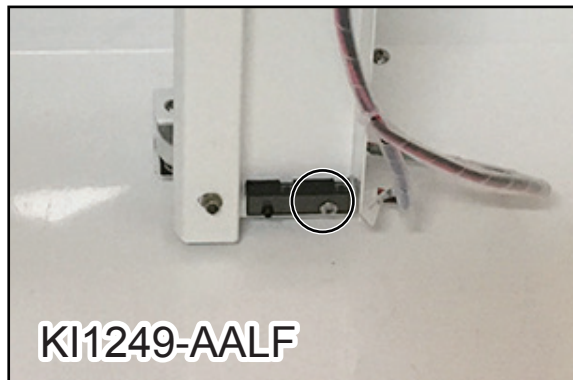
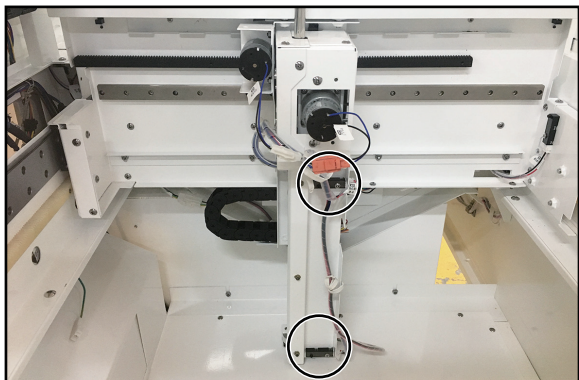

5.2.14 Replacement of colliding-sensors

1. Turn off the game-machine. Open the acrylic door with the key, remove the screen, there is 1 sensor on the jacking-rod, remove 2 screws to fix the lifting electric-eye fixing-iron and remove the lifting electric-eye fixing-iron.
2. Remove the screw to fix the sensor, pull out the corresponding terminal and remove the sensor, reinstall in a reverse order after replacing.

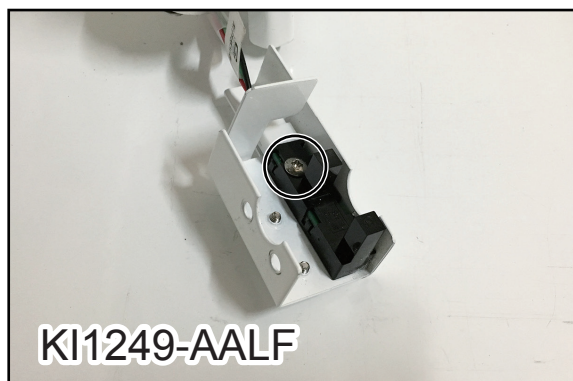
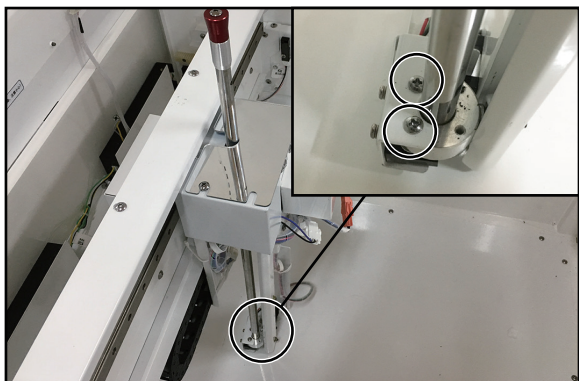

5.2.15 Replacement of sealing-plate opening/closing status sensors

1. Turn off the game-machine. Open the acrylic door with the key, remove the screen, there are 2 sensors on the eyelet fixing-iron.
2. Remove the nut to fix the sensor, pull out the corresponding terminal and remove the sensor, reinstall in a reverse order after replacing.

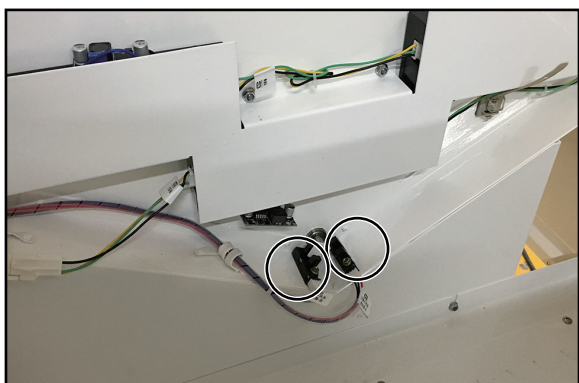

5.2.16 Replacement of sealing-plate opening/closing position sensors

1. Remove 2 screws to fix the small-door on the left-side of the game-machine.
2. Remove the screw to fix the sensor, pull out the corresponding terminal and remove the sensor, reinstall in a reverse order after replacing.

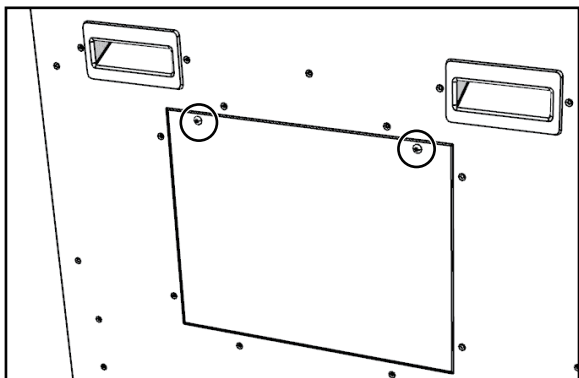

5.2.17 Replacement of optical-eye box

1. Turn off the game-machine. Open the acrylic door with the key, remove the screen, remove 4 nuts to fix the eyelet fixing-iron.
2. Remove 4 nuts to fix the optical-eye box, pull out the corresponding terminal and remove the optical-eye box, reinstall in a reverse order after replacing.



Warning

- All the headless socket screws in the motor shall be coated with medium-strength screw-glue.
- If the screws with high-strength screw-glue are too tight to remove, use a heat-gun to properly heat the position with high-strength screw-glue and then remove the screws.
- When using the heat-gun to heat the high-strength screw glue, be careful not to overheat so as not to damage the parts or burn the technicians.

5.2.18 Replacement of sealing-plate motor

1. Remove 2 screws to fix the small-door on the left-side of the game-machine.
2. Pull out the corresponding terminal and remove 2 nuts that fix No.1 motor iron on the prize door.

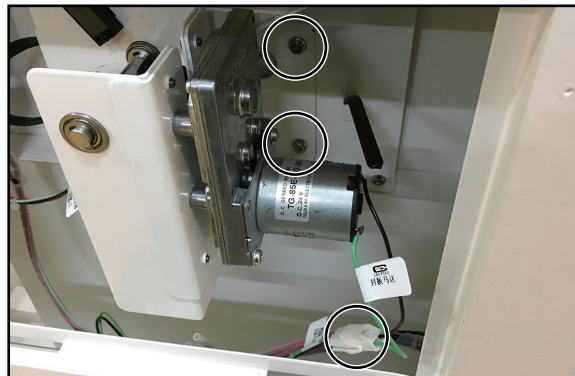
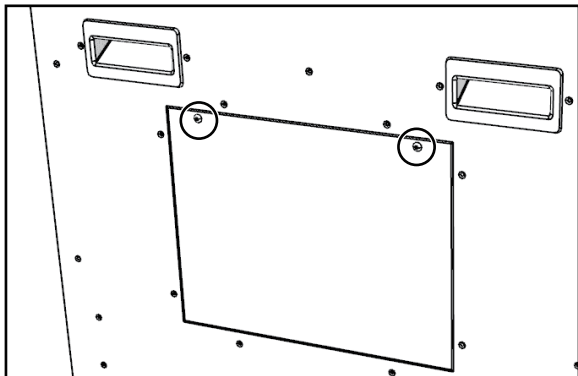

3. Remove 4 screws that fix No. 2 motor iron on the prize door.
4. Remove 4 screws that fix No. 1 motor iron on the prize door

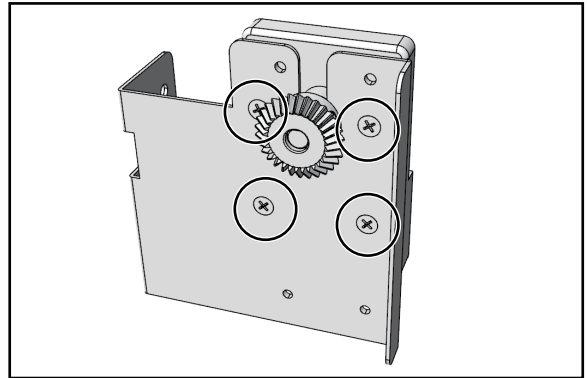
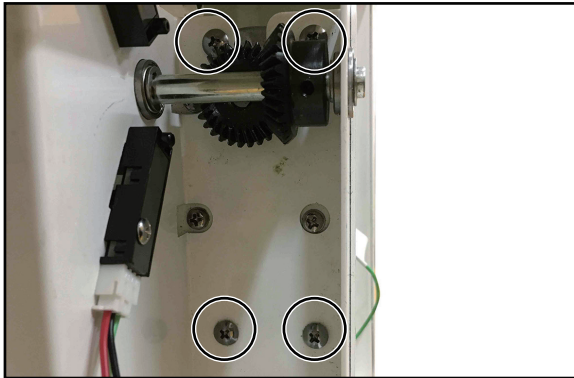

5. Remove the screws that fix the bevel gear and remove the sealing-plate motor, reinstall in a reverse order after replacing.

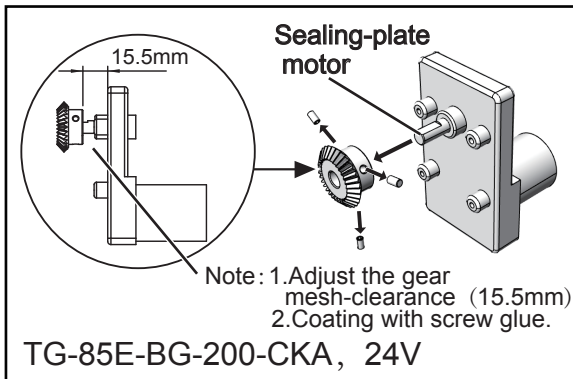

5.2.19 Replacement of longitudinally-moving motor

1. Turn off the game-machine. Open the acrylic door with the key, remove the screen, remove 2 screws to fix the cover-plate of longitudinally-moving motor.
2. Pull out the corresponding terminal and remove 2 nuts that fix the fixing-iron of the longitudinally-moving motor.

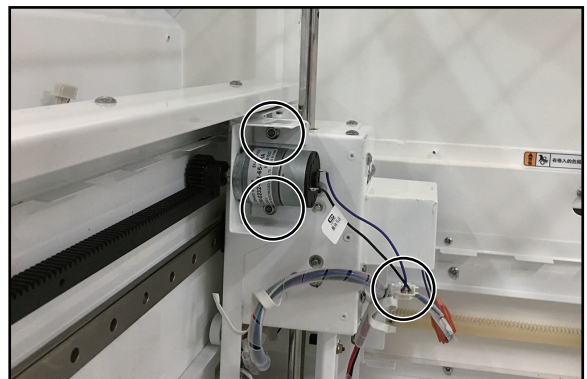
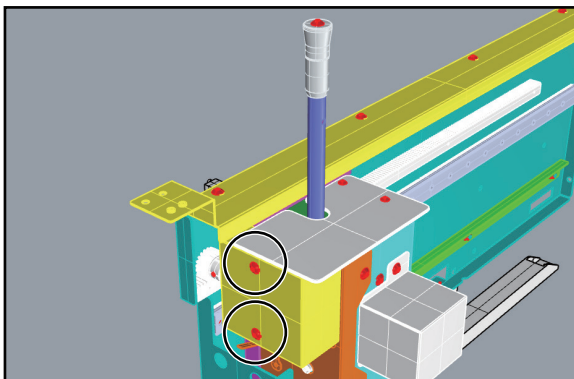

3. Remove 4 screws to fix the longitudinally-moving motor.
4. Remove the screws to fix the bevel gear and the longitudinally-moving motor, reinstall in a reverse order after replacing.

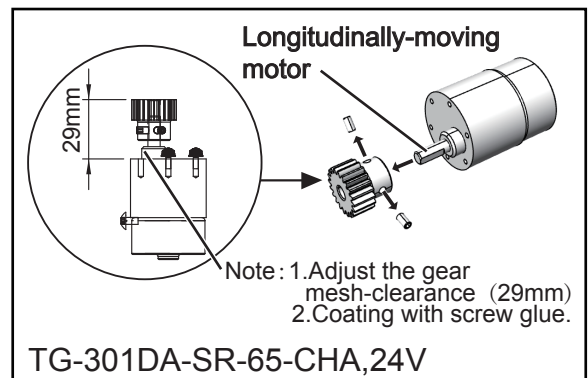
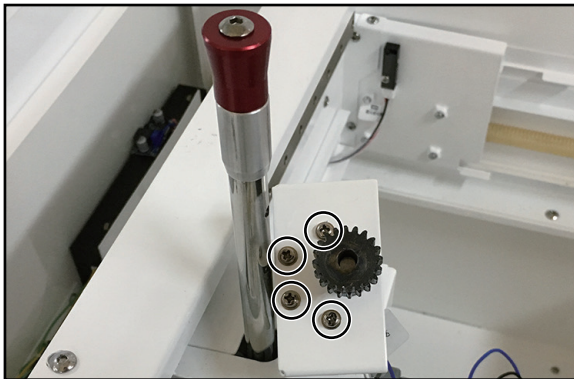

5.2.20 Replacement of horizontally-moving motor

1. Turn off the game-machine. Open the acrylic door with the key, remove the screen, remove 2 screws to fix the cover-plate of the horizontally-moving motor and pull out the corresponding terminal.
2. Remove 4 screws to fix the horizontally-moving motor.

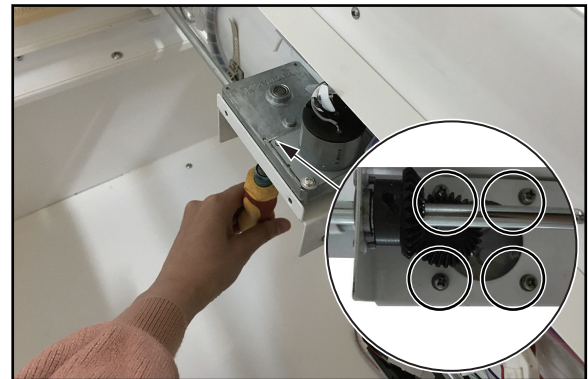
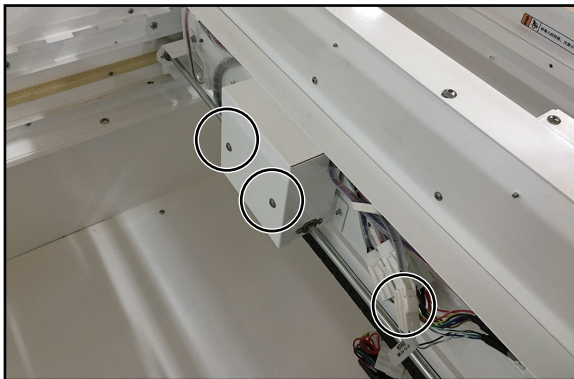

3. Remove the screws to fix the bevel gear and horizontally-moving motor, reinstall in a reverse order after replacing.

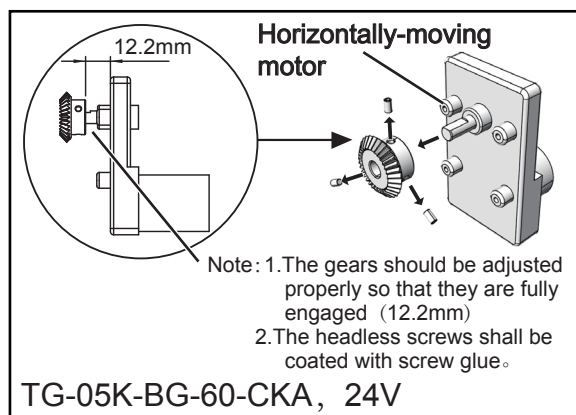

5.2.21 Replacement of moving-up/down motor or polyurethane roller

1. Turn off the game-machine. Open the acrylic door with the key, remove the net, remove 2 screws to fix the jacking-up motor cover-plate.
2. Tighten the screw to fix the clamping-roller fixing-plate (⊗ this screw is used to adjust the spring-pressure. The looser the screw is, the greater the pressure on the clamping-roller is and the further the jacking-rod moves up and down)

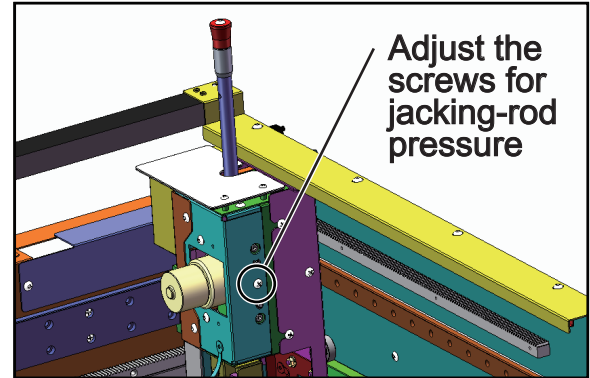
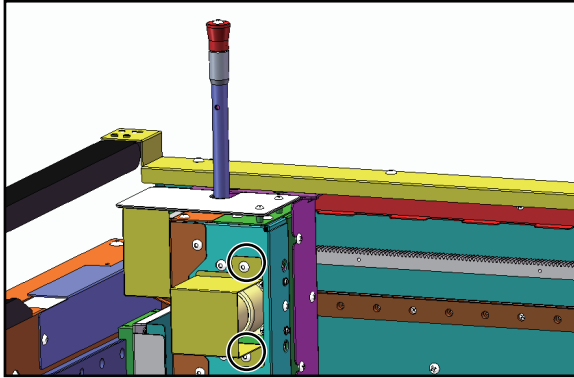

3. Remove 4 screws to fix the up/down moving motors and pull out the corresponding terminals.
4. Remove the screws to fix the bevel gears and up/down moving motors or polyurethane roller, reinstall in a reverse order after replacing.

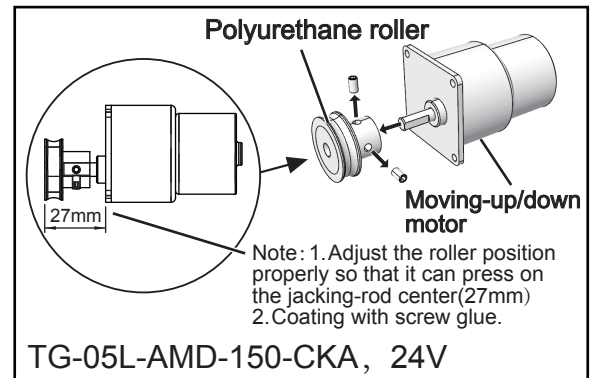
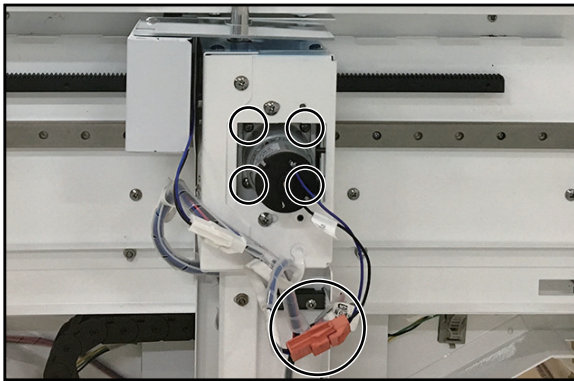

5.2.22 Replacement of prize net

1. Use the key to open the acrylic door, unscrew 4 white plastic screws to fix the net cover-plate and remove 2 net cover- plates.
2. Unscrew 6 white plastic screws to fix the prize net and turn the mould weight.

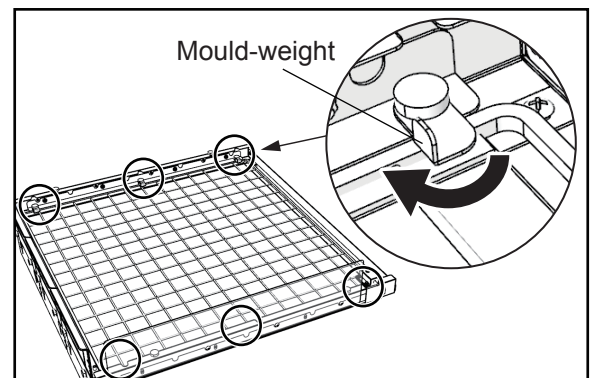
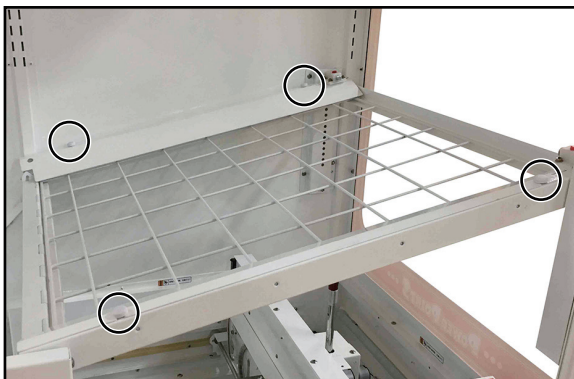

3. Remove the prize net, reinstall in a reverse order after replacing.



5.2.23 Replacement of top

1. Use the key to open the acrylic door, use the iron-bar to pass through the jacking-rod hole and remove the screw to fix the top.
2. Remove the top, reinstall in a reverse order after replacing.

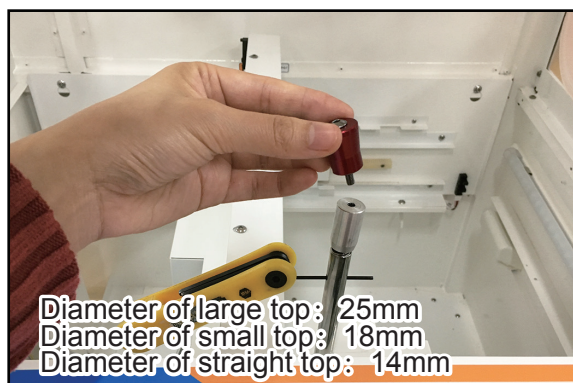

5.2.24 Replacement of speaker

1. Open the lower access door of the game-machine with the key.
2. Remove 4 screws on the loudspeaker, pull out the corresponding terminal and remove the loudspeaker, reinstall in a reverse order after replacing.

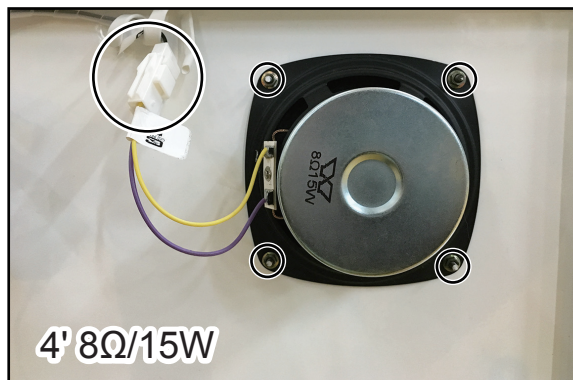

5.2.25 Replacement of coin-acceptor

1. Use the key to open the access-door on the lower right-side of the game-machine.
2. Remove 4 screws to fix the coin-acceptor, pull out the corresponding terminal and remove the coin-acceptor, reinstall in a reverse order after replacing.

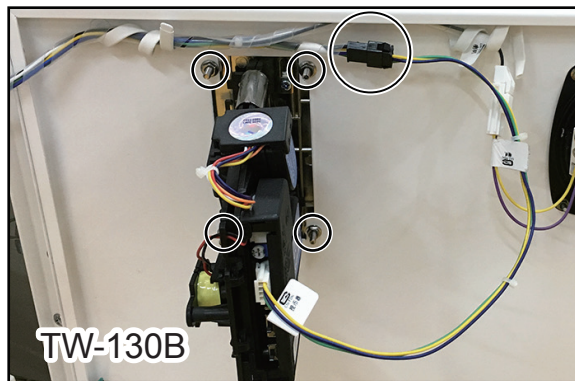

5.2.26 Change leakage switch

1. Turn off the game-machine, remove 4 screws to fix the power inlet box and then remove 2 screws to fix the leakage switch.
2. Pull out the corresponding terminal and remove the leakage switch, reinstall in a reverse order after replacing.

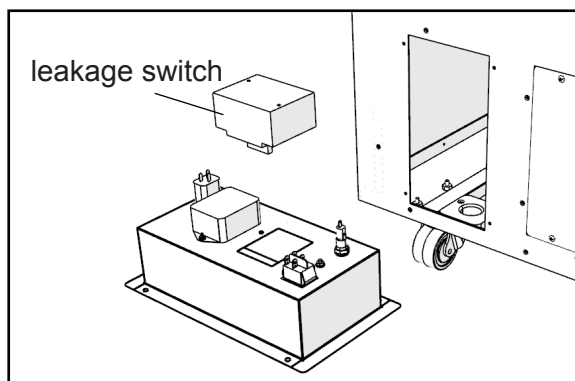
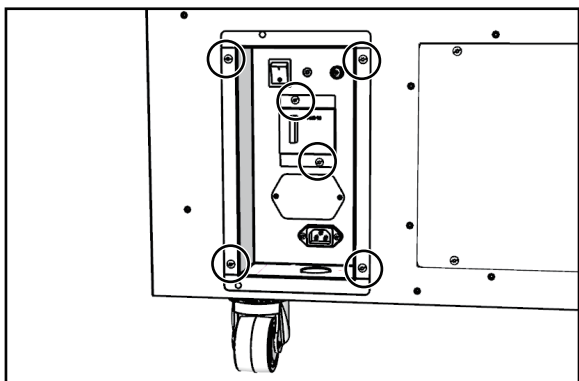

Warning

- When the leakage switch of the game-machine turns off automatically, check whether there is the leaky on the circuit and power-box. The circuits of PP-L0001~PP-L0012 should be emphatically checked. (please refer to the sections on P112-113)
- For the safety, "T" button must be pressed once a month and the leakage switch must be turned off automatically.



"T" button

5.2.27 Replacement of fuse

1. Turn off the game-machine, screw off fuse holder counterclockwise with Philips driver.
2. Remove fuse from fuse holder, and install in reverse sequence after replacement.

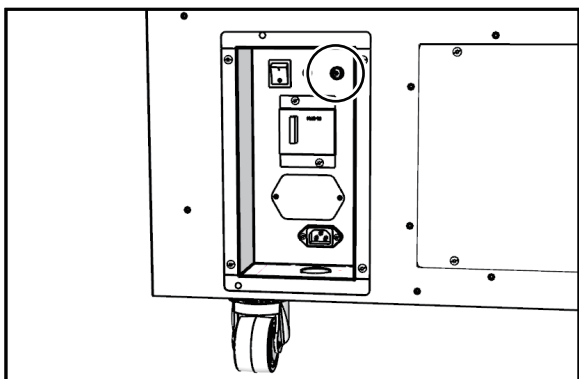

5.2.28 Change power-box

■ It must be operated by technicians

1. Turn off the game-machine and remove 6 screws to fix the back-door.
2. Remove 2 nuts to fix the power-box fixing-plate and pull out the power-box fixing-plate.

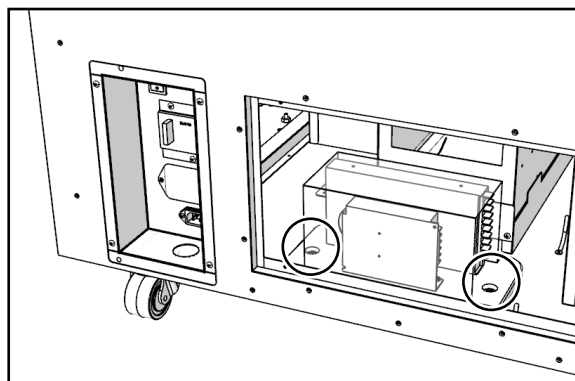
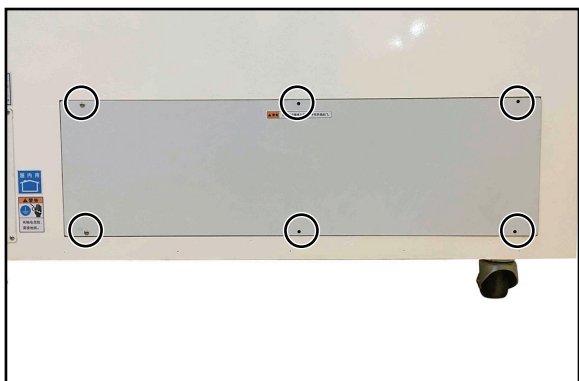

3. Remove 4 screws to fix the transparent PVC power-box cover.

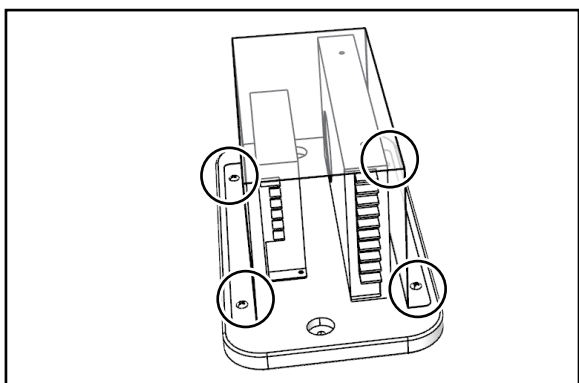

- Remove 2 nuts to fix the large 12V+5V power-box (remove 2 screws to fix the small 24V power-box), pull out the terminal corresponding to the power-box and remove the power-box, reinstall in a reverse order after replacing. (according to the label, insert the terminal back and then insert the terminal back according to the size of the pin seat.)



Large power-box: K10L-S300D12+5



Small power-box: K06L-U100S24

5.2.29 Replacement of PVC

- Open the acrylic door with the key, remove 4 screws to fix the front PVC and remove the front PVC, reinstall in a reverse order after replacing.
- Open the acrylic door with the key, remove 4 screws to fix the left/right PVC and remove the left/right PVC, reinstall in a reverse order after replacing.

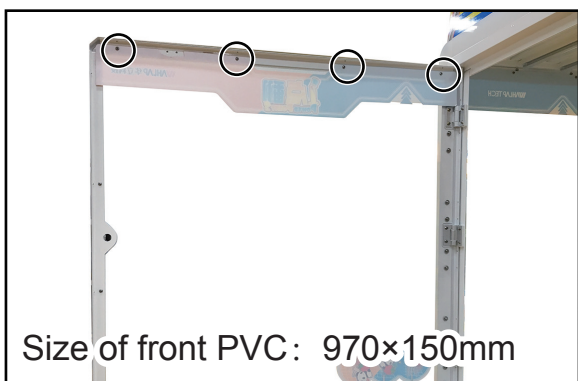

Size of front PVC: 970×150mm



Size of left/right PVC: 635×133mm

5.2.30 Replacement of moving components

- Turn off the game-machine. Open the acrylic door with the key, remove the screen, Remove 6 nuts that fix the horizontally-moving motor.
- Remove the horizontally-moving motor, reinstall in a reverse order after replacing.

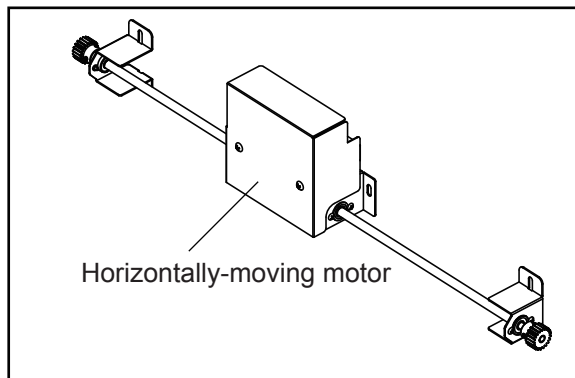
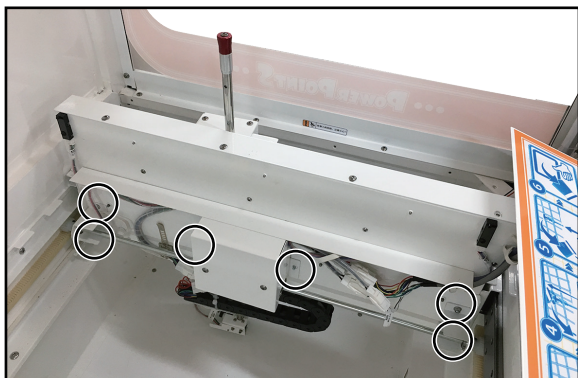

3. Remove 3 screws to fix the jacking-rod.
4. Remove the jacking-rod, reinstall in a reverse order after replacing.

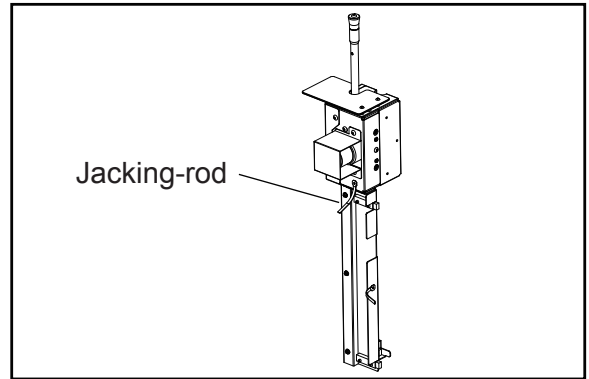
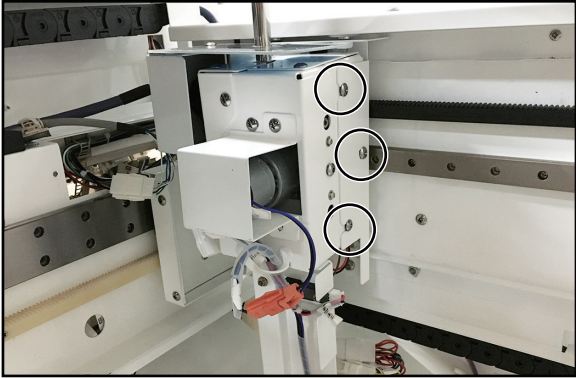

! Warning

- The jacking-rod should be cleaned regularly to avoid oil-slick.

5.2.31 Replacement of sealing-door spring

1. Remove 2 screws to fix the small-door on the left-side of the game-machine.
2. Remove 4 nuts that fix the sealing-plate motor.

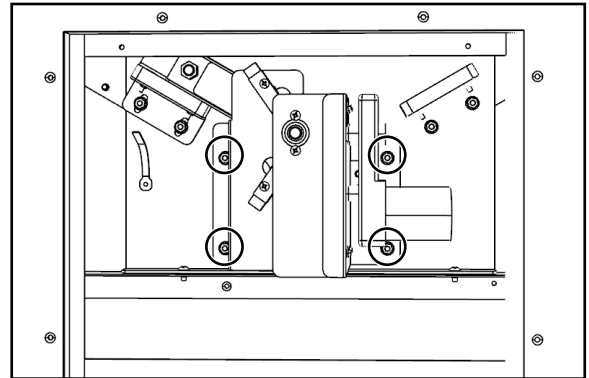
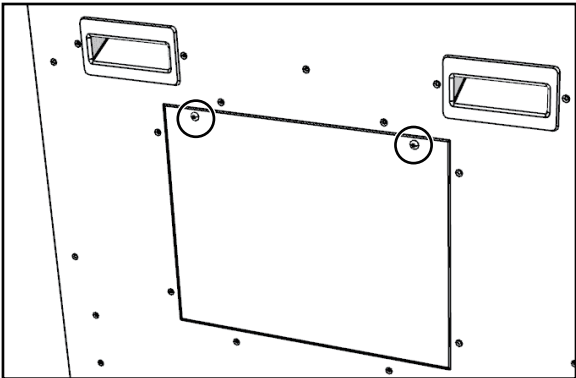

3. Remove the door-sealing spring, reinstall in a reverse order after replacing.

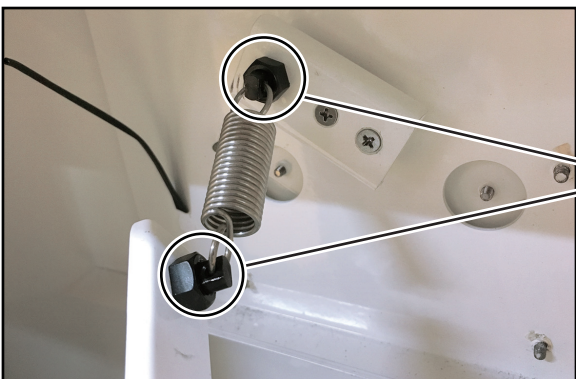

- Note: 1. The screws shall be screwed in as far as possible to prevent the scratching!
 2. The screw head shall be parallel to the shaft!

5.2.32 Replacement of prize baffle

There are 2 prize-baffles to prevent prize from falling off automatically. The long prize-baffle is used for the long prize and the short prize-baffle is used for the short prize.

1. Open the acrylic door with the key and unscrew 2 white plastic screws to fix the prize-baffle.
2. Remove the prize-baffle, reinstall in a reverse order after replacing.

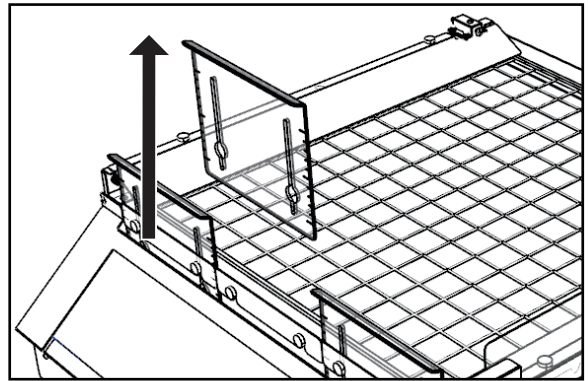
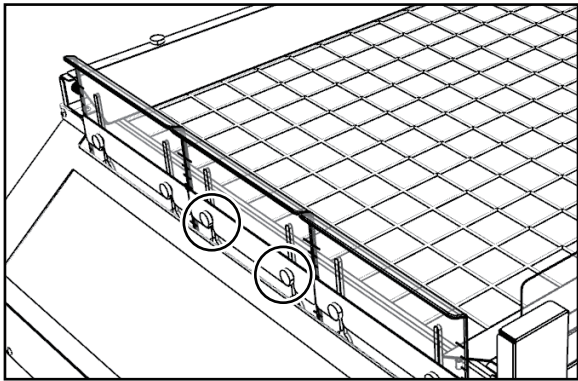

Long prize baffle: 185×150mm
Short prize baffle: 185×80mm

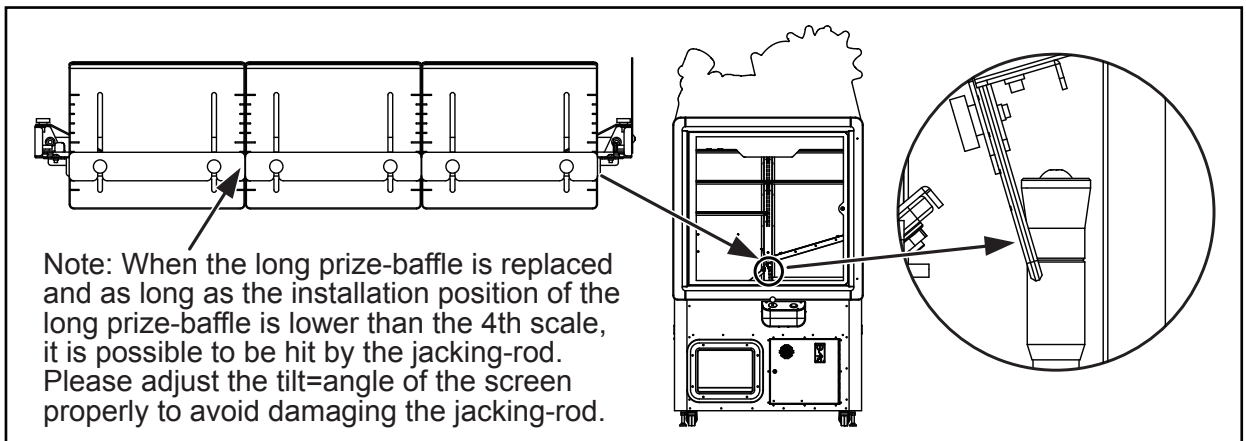

5.2.33 Specification for height-adjusting net

1. Press the red button, pop up the metal pin and then adjust the height of the ramp net
2. After aligning the position, push in the metal pin to lock the ramp net.

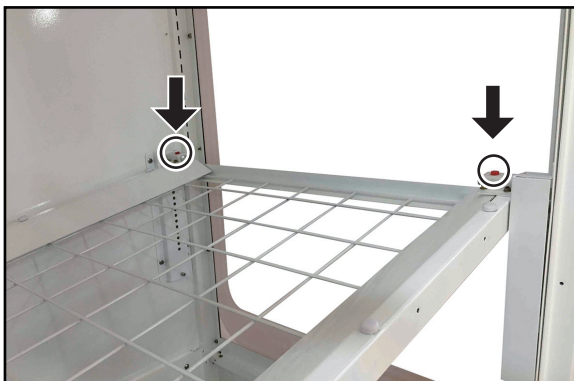

5.2.34 Specification for the height of the ramp net

There are 2 kinds of adjusting-height for the ramp net, such as upward adjustment or backward adjustment.

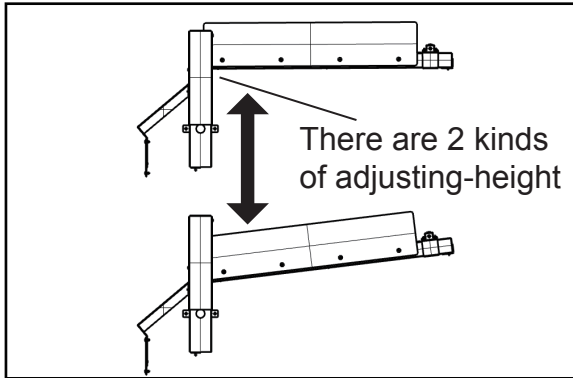

Upward adjustment steps for the ramp net

1. Open the acrylic door with the key and remove 2 rubber-head cross-groove screws to fix both net side-plates.
2. Remove 2 screws to fix the net pin-seat, move the net pin-seat up to the screw hole and then fix the net pin-seat with 2 screws.

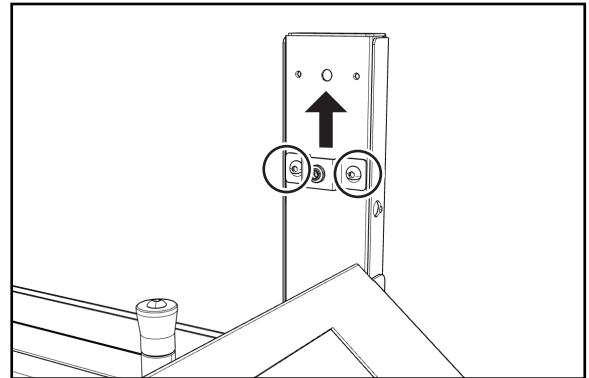
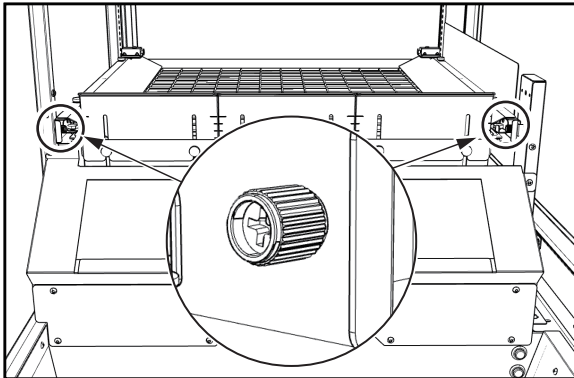

3. Use 1 rubber-head cross-groove screw to fix both net side-plates.
4. Remove 6 screws to fix the prize ramp net, move the prize ramp net up to the screw-hole and then fix the prize ramp net with 6 screws.

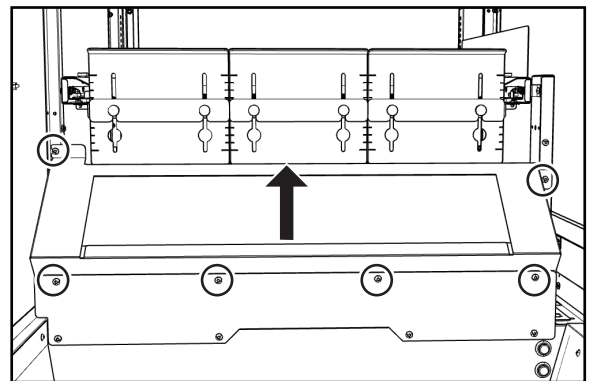
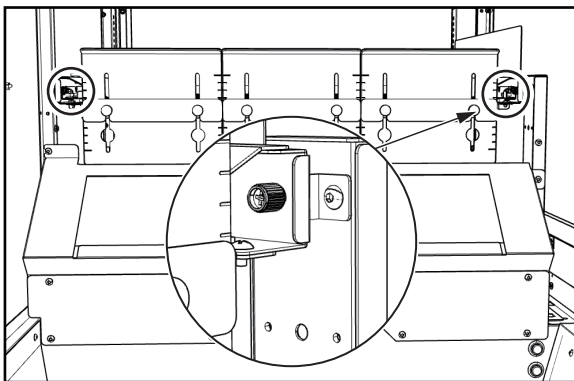

Note: For backward adjustment, the 4th step shall be completed first, then the 1st, 2nd and 3rd step.

5.2.35 Descriptions for damping-adjustable hinge

1. Open the acrylic door with the key and the player can see 3 damped adjustable-hinges located in the acrylic door.
2. Use the 6-point wrench to adjust the damping. When adjusting clockwise, the damping becomes greater. When adjusting counterclockwise, the damping becomes smaller. The damping affects the opening of the large acrylic door.

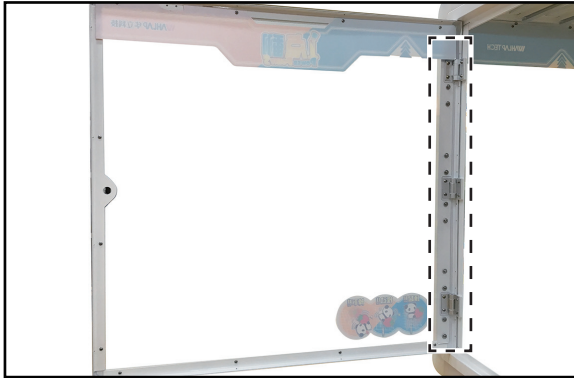

5.2.36 Description for power socket

1. Open the acrylic door with the key and there is a power socket in the upper right corner of the game-machine.
2. Remove 2 screws to fix the left small-door and player can see a power socket on the left.

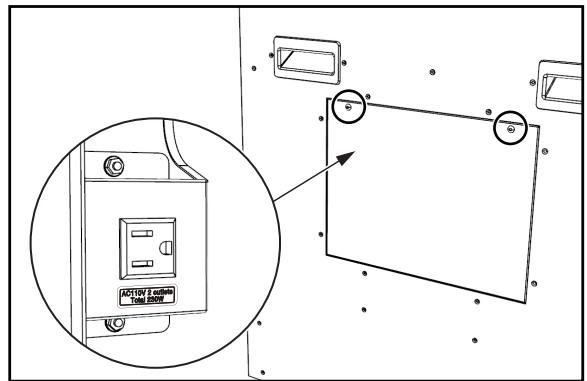
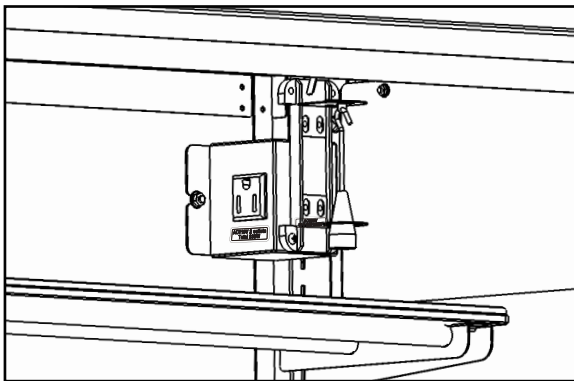

Warning

- 2 power sockets: AC110V and 230W in all

5.2.37 Description for LCD position and operation steps

Position description: the display screen is fixed at the bottom of the left display-board, which can play the game-play animation.

Usage steps:

1. Open the acrylic door with the key, put in the display screen and wire in the circle, as shown in Fig 1.
2. Remove 2 screws to fix the left small-door and player can see a power-socket on the left. Then insert the power plug into the power socket and the display screen can be used.

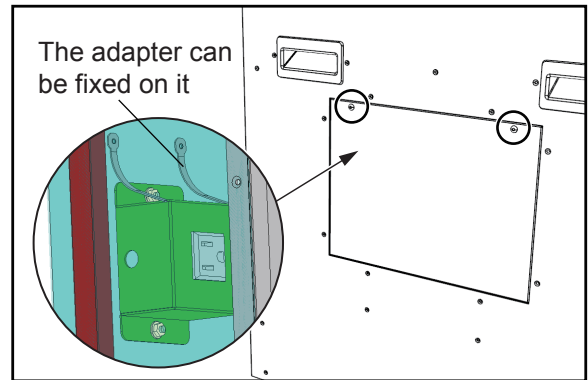
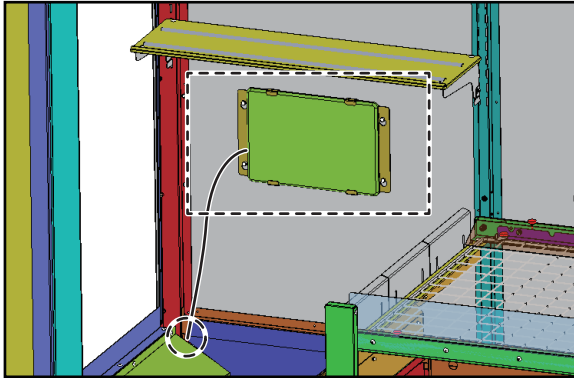

5.2.38 Descriptions for prize-rack

1. The height of the prize-rack can be adjusted according to the prize size.
2. The display-board buckle shall be installed before transport to prevent the prize-rack from moving or falling.

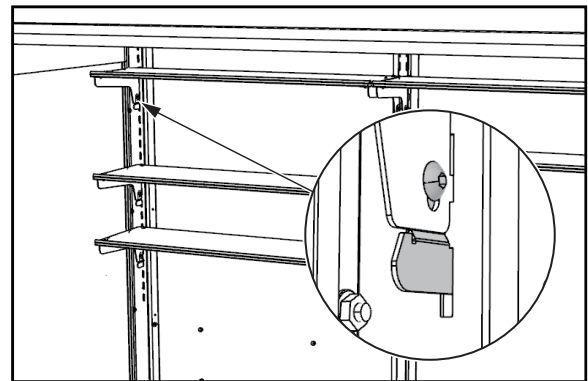
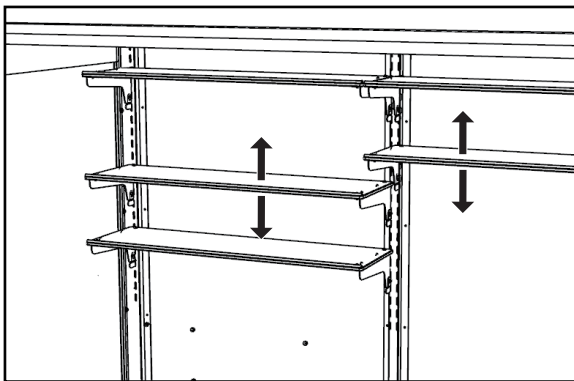

3. There are 2 kinds of prize-racks on the game-machine: Display-board and prize-rack tube.

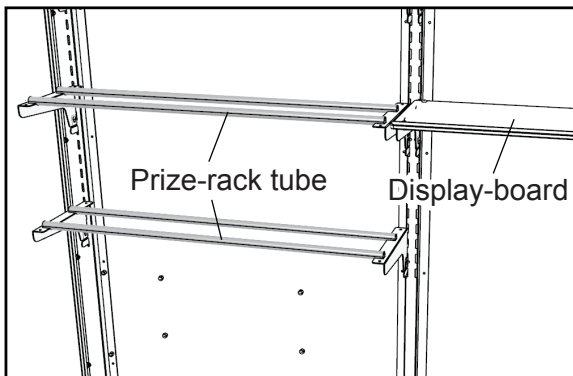

Installation steps of prize-rack tube

1. The prize-rack tube shall be directly inserted into the display-board supporting-iron.
2. Rotate the prize-rack tube with the right-angle facing up to lock the prize-rack tube.
(complete this step to prevent jacking-up of prize-rack tube)

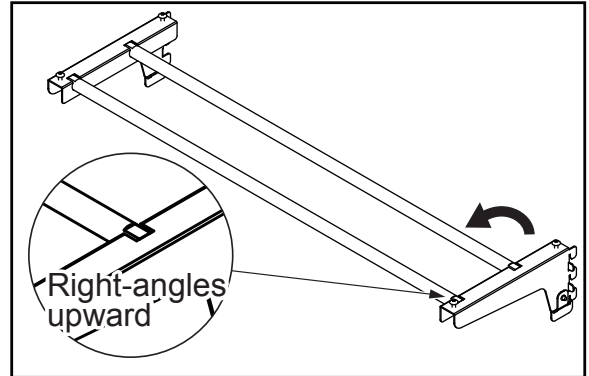
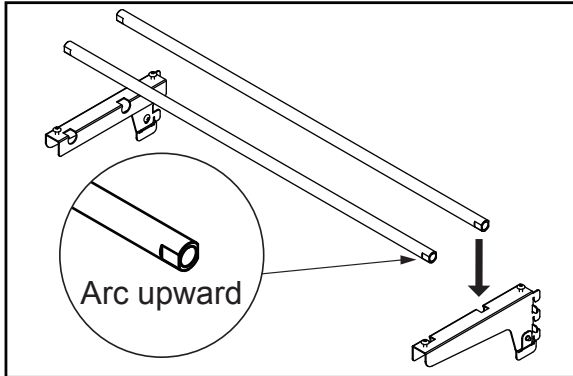

5.2.39 Descriptions for hole-cover of lower cover-plate

When the game-area cover-plate of the game-machine needs to be cleaned or the prizes falling from the grid onto the game-area cover-plate of the game-machine needs to be taken out, remove the hole-cover of lower cover-plate first and then clean or take out the prizes.

Removing steps for hole-cover of lower cover-plate

1. Use the key to open the access-door on the lower right-side of the game-machine.
2. Turn off the game-machine, remove the white plastic screw to fix the hole-cover of the lower cover-plate and remove the hole-cover of the lower cover-plate.



3. Clean or take out the prizes. Reinstall in a reverse order after completion.



5.3 Replacement or repairing of main-board

1. Turn off the rocker-type switch behind the game-machine. (near the fuse)
2. Use the key to open the access-door on the lower right-side of the game-machine.

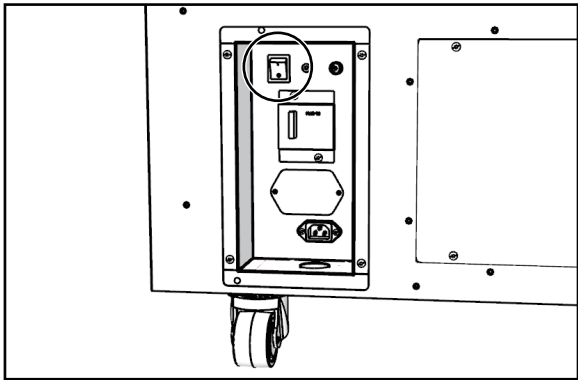

3. Turn off and remove 2 screws that fix PCB fixing-iron.
4. Unplug the terminals, with a total of 8 terminals.



5. Pull out PCB fixing-iron and remove 2 screws that fix PCB cover.
6. Remove 6 screws that fix the main-board, unfasten the cable tie, pull out the terminal of the main-board and remove the main-board, reinstall in a reverse order after replacing.
(The terminals should be inserted back according to the label and the size of the pin)

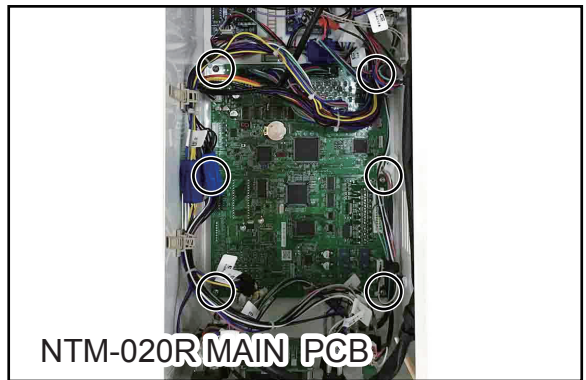

● Main-board (NTM-020R MAIN PCB)

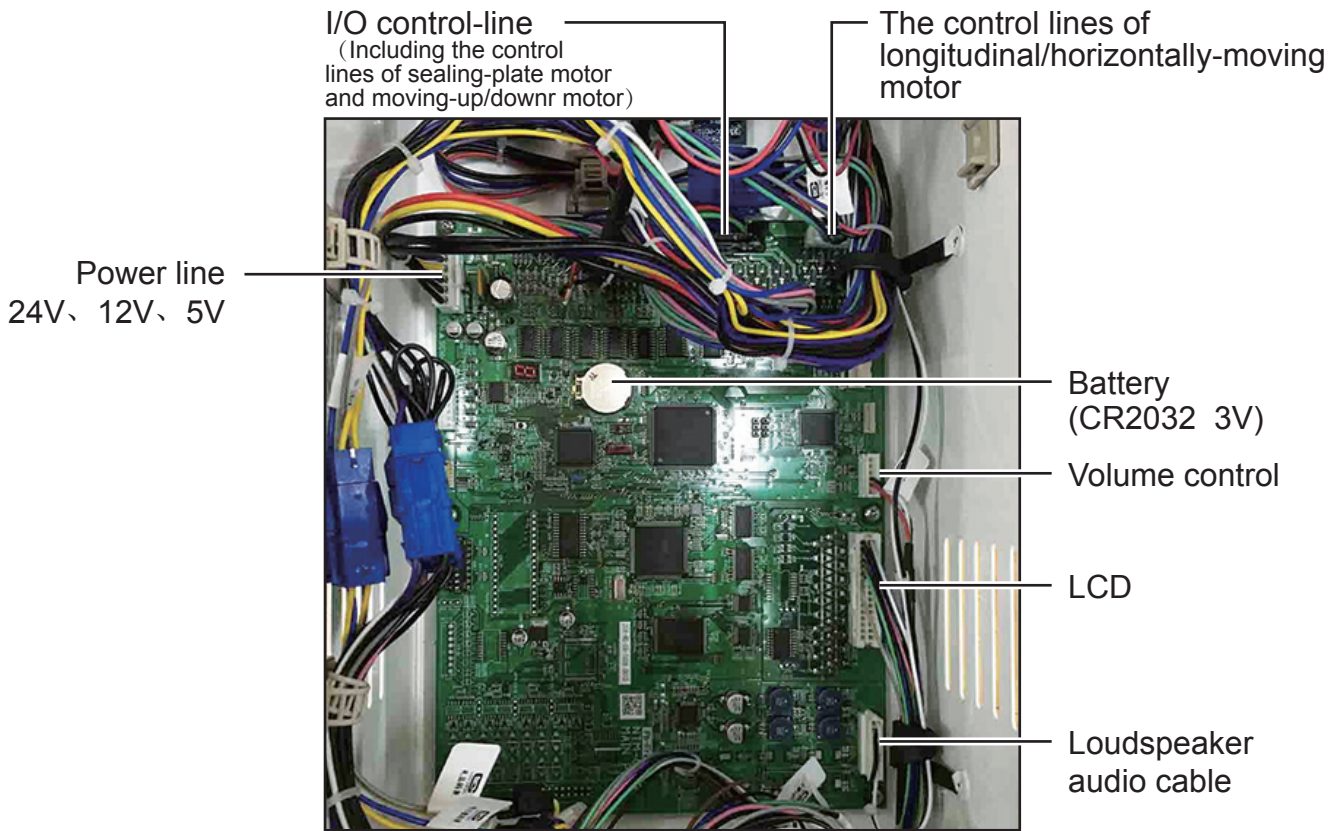

● Motor driver-plate (WL_KC_MotorDrive_V1.0)

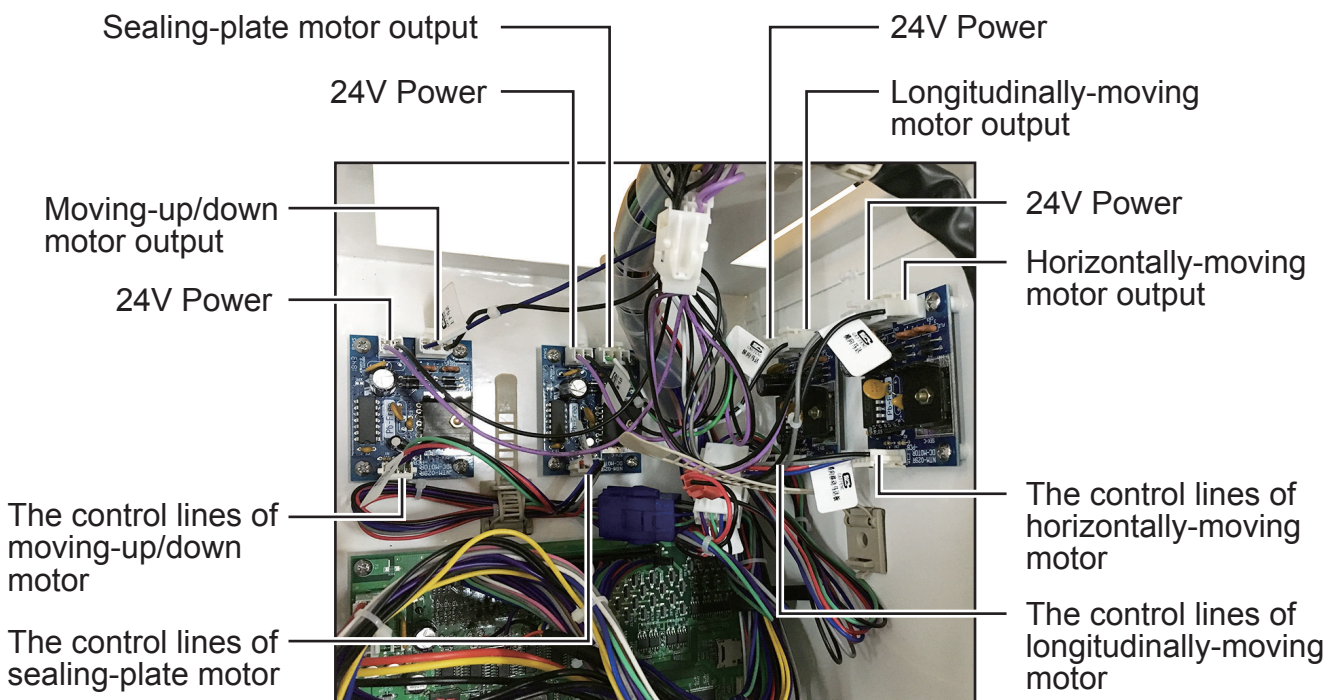

6. Assembly

6.1 Assembly tree diagram

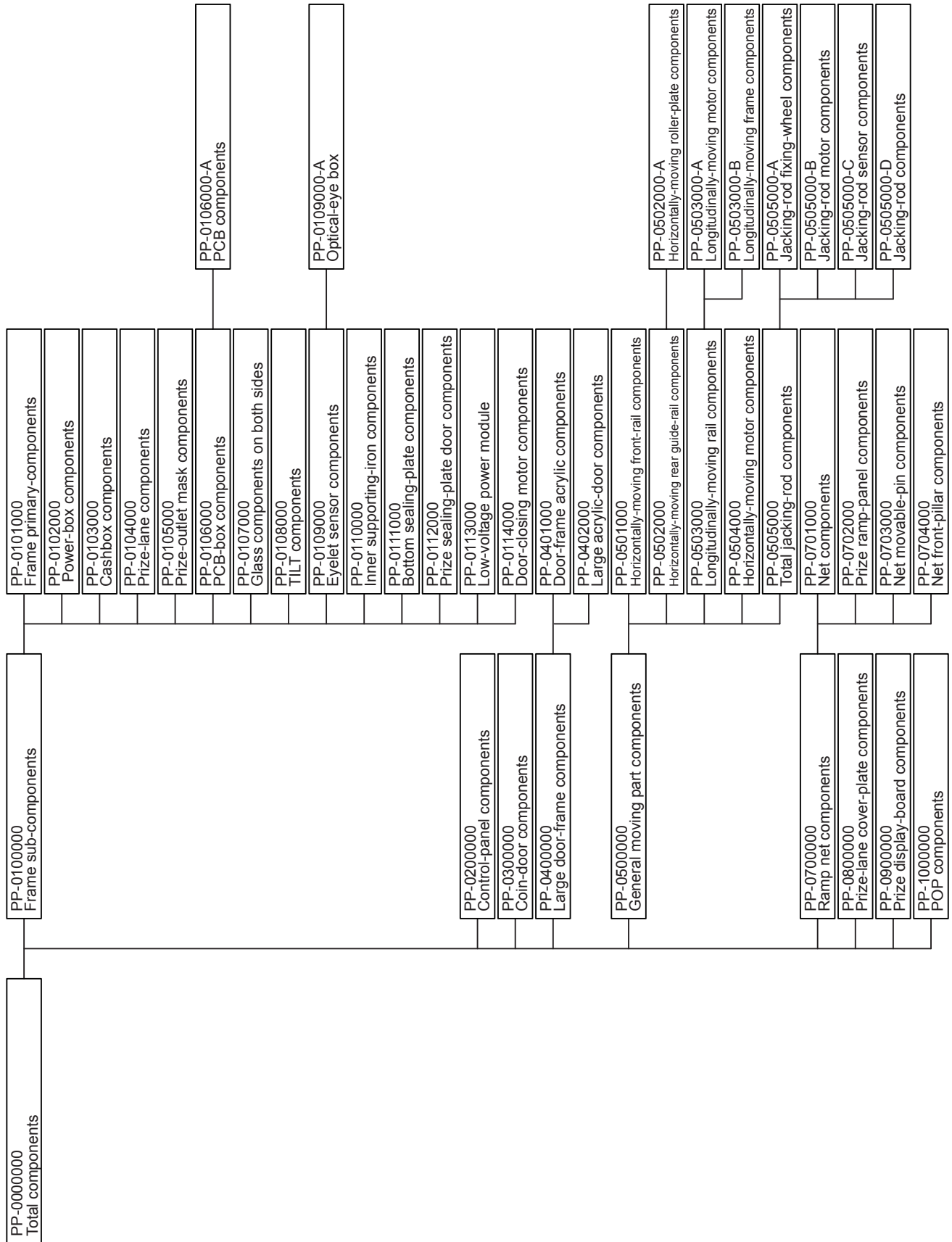

6.2 Total components (PP-0000000)

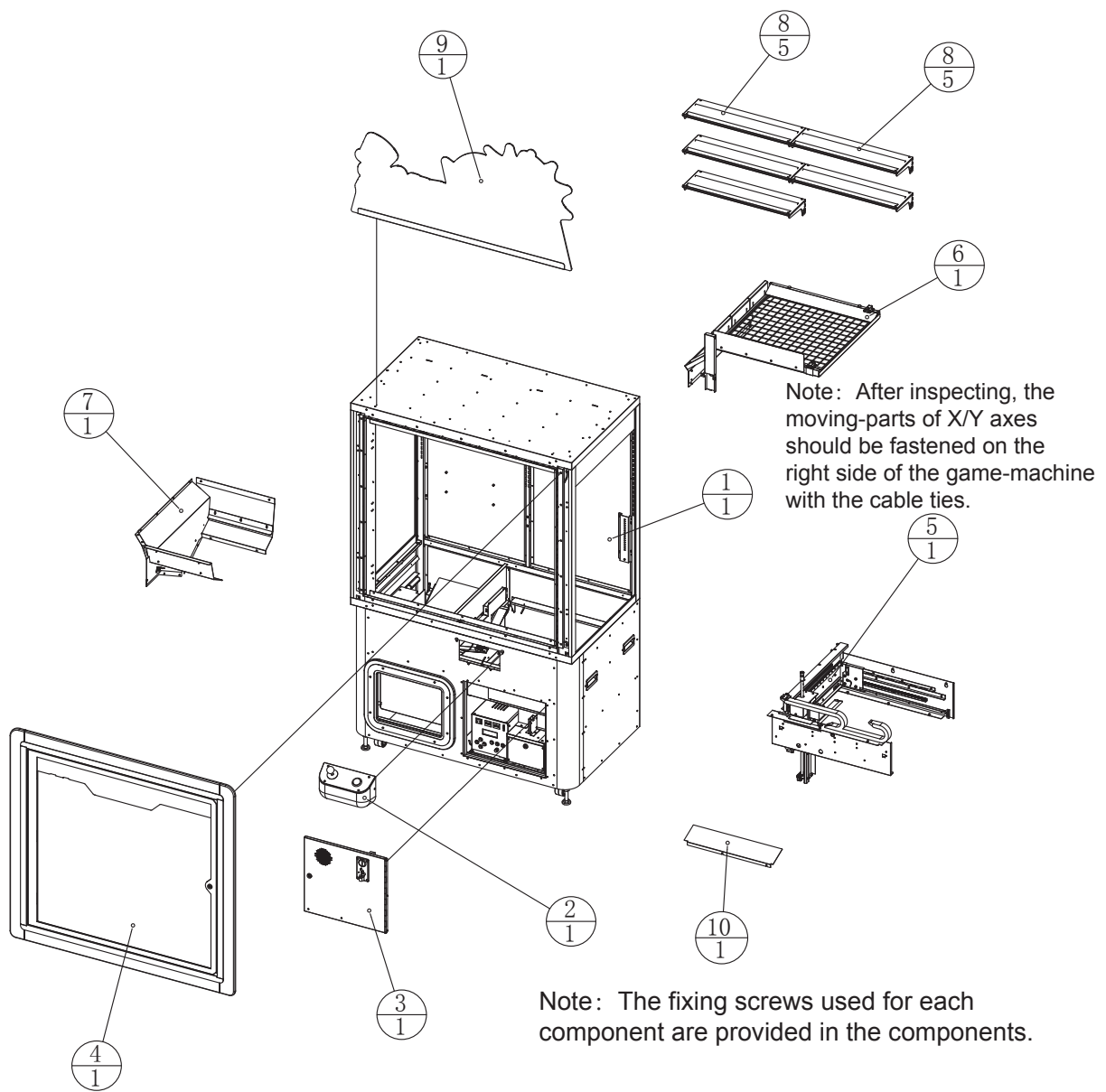

| | | | | | |
|----|-------------|--|--------------------------|-----|------|
| 10 | PP-0000A01 | Horizontally-moving drag-chain cover-plate | SPCC-1.2T | 1 | |
| 9 | PP-1000000 | POP components | | 1 | |
| 8 | PP-0900000 | Prize displaying-board components | | 5 | |
| 7 | PP-0800000 | Prize-channel cover-plate components | | 1 | |
| 6 | PP-0700000 | Ramp-net components | | 1 | |
| 5 | PP-0500000 | Moving-parts components | | 1 | |
| 4 | PP-0400000 | Big door-frame components | | 1 | |
| 3 | PP-0300000 | Coin-door components | | 1 | |
| 2 | PP-0200000 | Control-panel components | | 1 | |
| 1 | PP-0100000 | Secondary frame components | | 1 | |
| SN | Drawing No. | Name | Materials/specifications | Qty | Note |

6.3 Frame sub-components (PP-0100000)

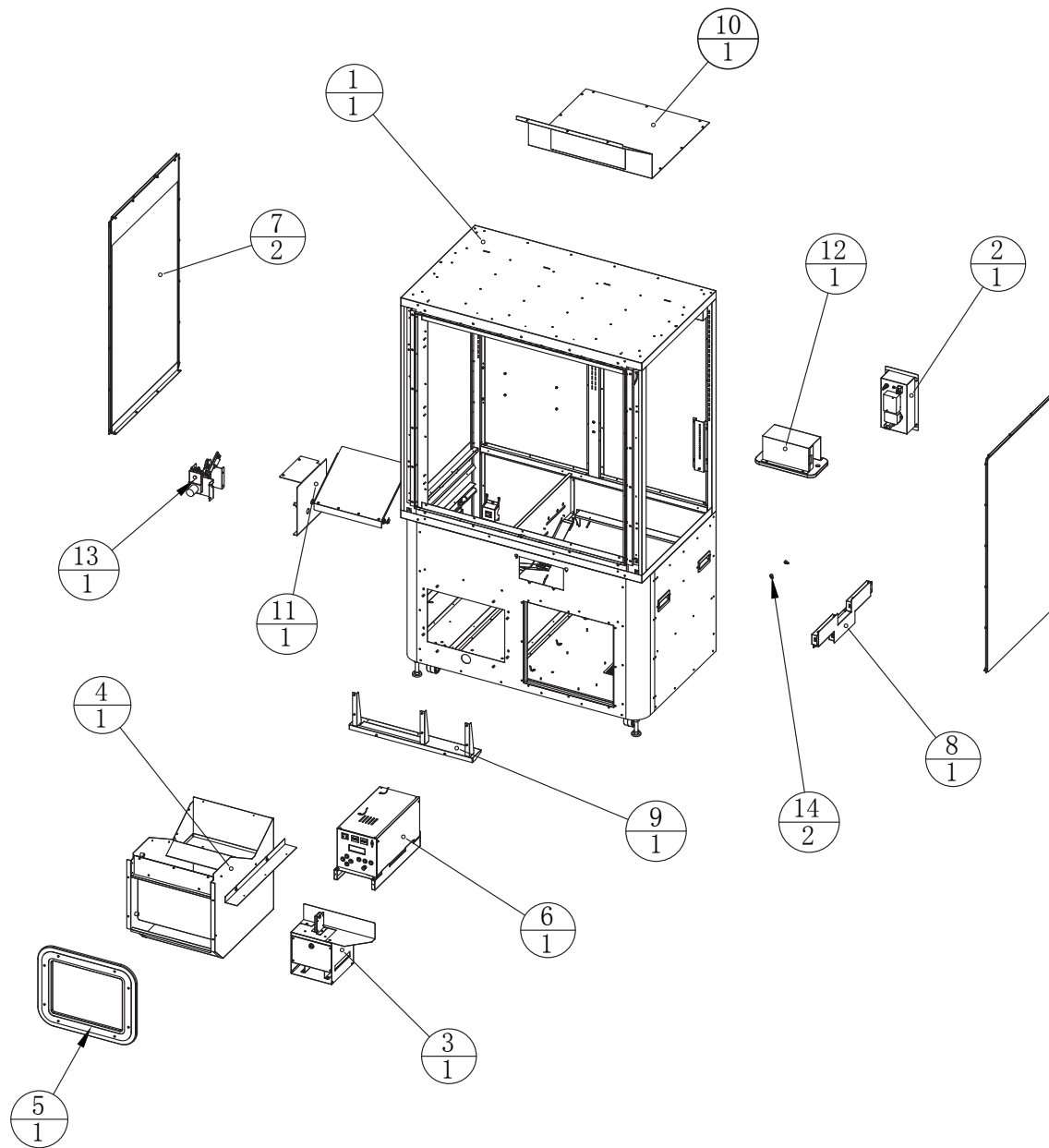

| | | | | | |
|----|-------------|------------------------------------|--------------------------|-----|--------------|
| 14 | | R type clamp | 10.4m | 2 | 1.9.XJ010020 |
| 13 | PP-0114000 | Sealing-door motor components | | 1 | |
| 12 | PP-0113000 | Low-voltage power module | | 1 | |
| 11 | PP-0112000 | Prize sealing-plate door component | | 1 | |
| 10 | PP-0111000 | Bottom sealing-plate components | | 1 | |
| 9 | PP-0110000 | Inner supporting-iron components | | 1 | |
| 8 | PP-0109000 | Exhaust-sensor components | | 1 | |
| 7 | PP-0107000 | Side glass-door components | | 2 | |
| 6 | PP-0106000 | PCB-box rack components | | 1 | |
| 5 | PP-0105000 | Prize outlet-mask components | | 1 | |
| 4 | PP-0104000 | Prize lane components | | 1 | |
| 3 | PP-0103000 | Cashbox components | | 1 | |
| 2 | PP-0102000 | Power box components | | 1 | |
| 1 | PP-0101000 | Primary frame components | | 1 | |
| SN | Drawing No. | Name | Materials/specifications | Qty | Note |

6.3.1 Frame primary-components (PP-0101000)

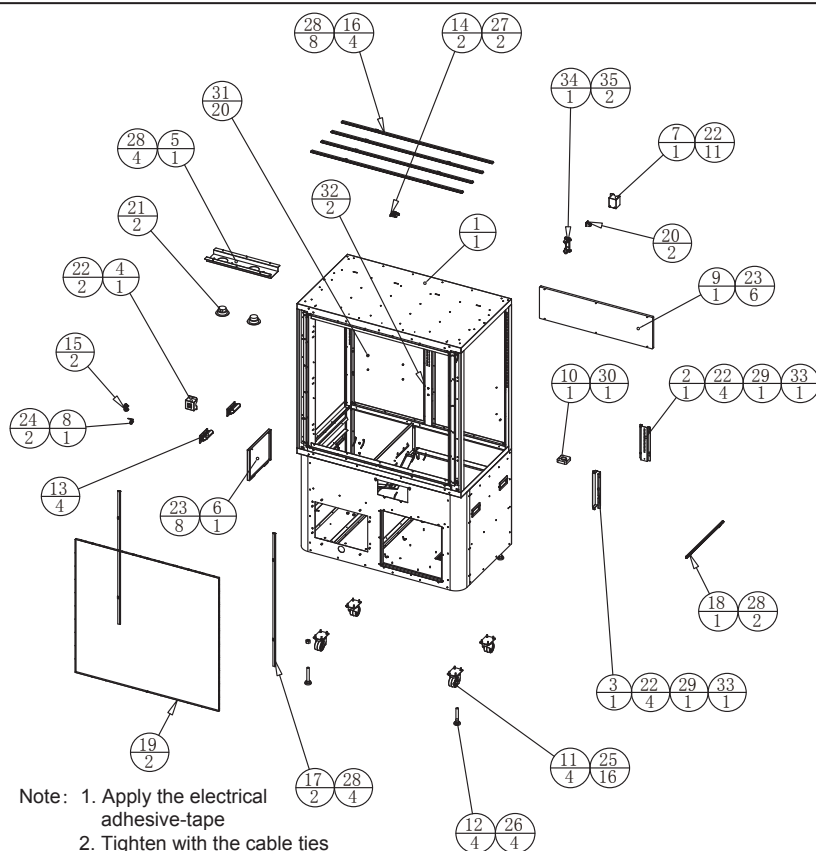

- Note: 1. Apply the electrical adhesive-tape
2. Tighten with the cable ties

| | | | | | |
|----|-------------|------------------------------------|---|-----|---------------|
| 35 | | Cross large flat head screw | M3*12 (chrome plated) | | 1.6.LS231022 |
| 34 | | Anti surge device | KWM188Machine use | | 1.4.QT200010 |
| 33 | | Isolating cylinder | 5*7*5mm | 2 | 1.6.GL105010 |
| 32 | | Hexagon socket flat-head screw | M4*8 (chrome plated) | 2 | 1.6.LS140032 |
| 31 | | Cap nut | M4 (chrome plated) | 20 | 1.6.LM404012 |
| 30 | | Hexagon socket flat-head screw | M4*12 (chrome plated) | 1 | 1.6.LS141022 |
| 29 | | Hexagon socket flat-head screw | M4*10 (stainless steel) | 2 | 1.6.LSF41015 |
| 28 | | Cross flat-head screw | M3*8 (chrome plated) | 18 | 1.6.LS230032 |
| 27 | | hexagon nut with flange | M3 (color coating) | 2 | 1.6.LM203013 |
| 26 | | Hexagonal nut | M16 (color coating) | 4 | 1.6.LM116013 |
| 25 | | Cross round-head screw | M6*20 (chrome plated) | 16 | 1.6.LS862012 |
| 24 | | Cross flat-head screw | M4*10 (chrome plated) | 2 | 1.6.LS241012 |
| 23 | | Hexagon socket flat-head screw | M4*20 (chrome plated) | 8 | 1.6.LS142012 |
| 22 | | hexagon nut with flange | M4 (color coating) | 11 | 1.6.LM204013 |
| 21 | | Ceiling lamp | 3*1W yellow DC12V | 2 | 1.4.ZM9F0011 |
| 20 | | Power socket | Card-type 3-hole 15A/AC125V (American-standard) | 2 | 1.5.XC203020 |
| 19 | | 5050 soft lamp-bar | DC12V RGB60 lamp L=2050mm | 2 | 1.4.ZM9E0509 |
| 18 | | 5050 hard lamp-bar (aluminum case) | DC12V white 60 lamp L=500mm | 1 | 1.4.ZM9E0085 |
| 17 | | 5050 hard lamp-bar (aluminum case) | DC12V white 60 lamp L=1000mm | 2 | 1.4.ZM9E0072 |
| 16 | | 5050 hard lamp-bar (aluminum case) | DC12V white 60 lamp L=1100mm | 4 | 1.4.ZM9E0073 |
| 15 | | Circular card-type button | Sanwa red SDP-103C-22RB | 2 | 1.4.AJ500012# |
| 14 | | Sensor | KI1300-AA07LF | 2 | 5.4.WECHE0004 |
| 13 | | Plastic handle | white for wooden case | 4 | 1.8.AA000020 |
| 12 | | Anchor bolt | M16*Y100 (color coating) | 4 | 1.6.LSV99013 |
| 11 | | Activity castor | 2.5'low gravity-center | 4 | 1.4.JL302520 |
| 10 | PP-0101B02 | Crossboard | MDF-20.0T | 1 | |
| 9 | PP-0101B01 | Rear-door plank | MDF-15.0T | 1 | |
| 8 | PP-0101A08 | Sealing-plate limit short-iron | SPCC-1.2T | 1 | |
| 7 | PP-0101A07 | Socket | SPCC-1.2T | 1 | |
| 6 | PP-0101A06 | Side-door | SPCC-1.2T | 1 | |
| 5 | PP-0101A05 | Spot-lamp fixing-iron | SPCC-1.2T | 1 | |
| 4 | PP-0101A04 | Power socket holder | SPCC-1.2T | 1 | |
| 3 | PP-0101A03 | Height front-adjustment orifice | SPCC-1.2T | 1 | |
| 2 | PP-0101A02 | Height rear-adjustment orifice | SPCC-1.2T | 1 | |
| 1 | PP-0101A01 | Frame weldment | | 1 | |
| SN | Drawing No. | Name | Materials/specifications | Qty | Note |

6.3.2 Power-box components (PP-0102000)

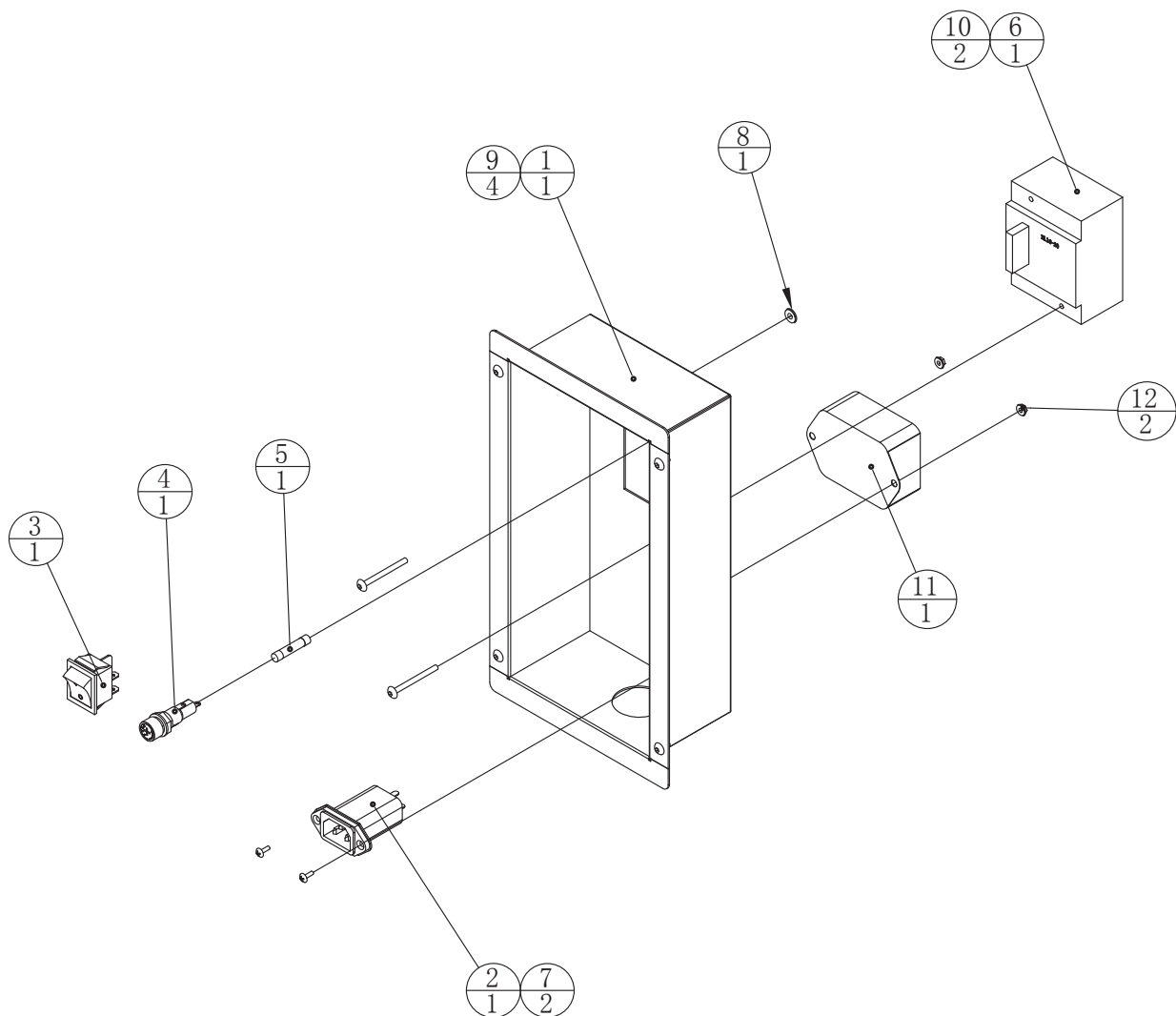

| | | | | | |
|----|-------------|--------------------------------|-----------------------------|-----|--------------|
| 12 | | hexagon nut with flange | M3 (color-coating) | 2 | 1.6.LM203013 |
| 11 | | Pulse-group filter | YB24D3-6A-Q | 1 | 1.4.LB100010 |
| 10 | | Hexagon socket flat-head screw | M4*40 (chrome plated) | 2 | 1.6.LS144012 |
| 9 | | Hexagon socket flat-head screw | M4*8 (chrome plated) | 4 | 1.6.LS140032 |
| 8 | | hexagon nut with flange | M4 (color-coating) | 1 | 1.6.LM204013 |
| 7 | | Cross flat-head screw | M3*8 (chrome plated) | 2 | 1.6.LS230032 |
| 6 | | Leakage protection switch | CHNT NL18-20 | 1 | 1.4.SW802011 |
| 5 | | Fuse tube | 218 series T3.15A/5*20 250V | 1 | 1.4.BX110050 |
| 4 | | Cartridge fuse | Cross-head MF527A | 1 | 1.4.BX300010 |
| 3 | | rocker type switch | 4P KCD7-2211N | 1 | 1.4.SW604010 |
| 2 | | filter | 15GEEG3E 10A/250V | 1 | 1.4.LB100020 |
| 1 | PP-0102A01 | Power inlet box | SPCC-1.2T | 1 | |
| SN | Drawing No. | Name | Materials/specifications | Qty | Note |

6.3.3 Cashbox components (PP-0103000)

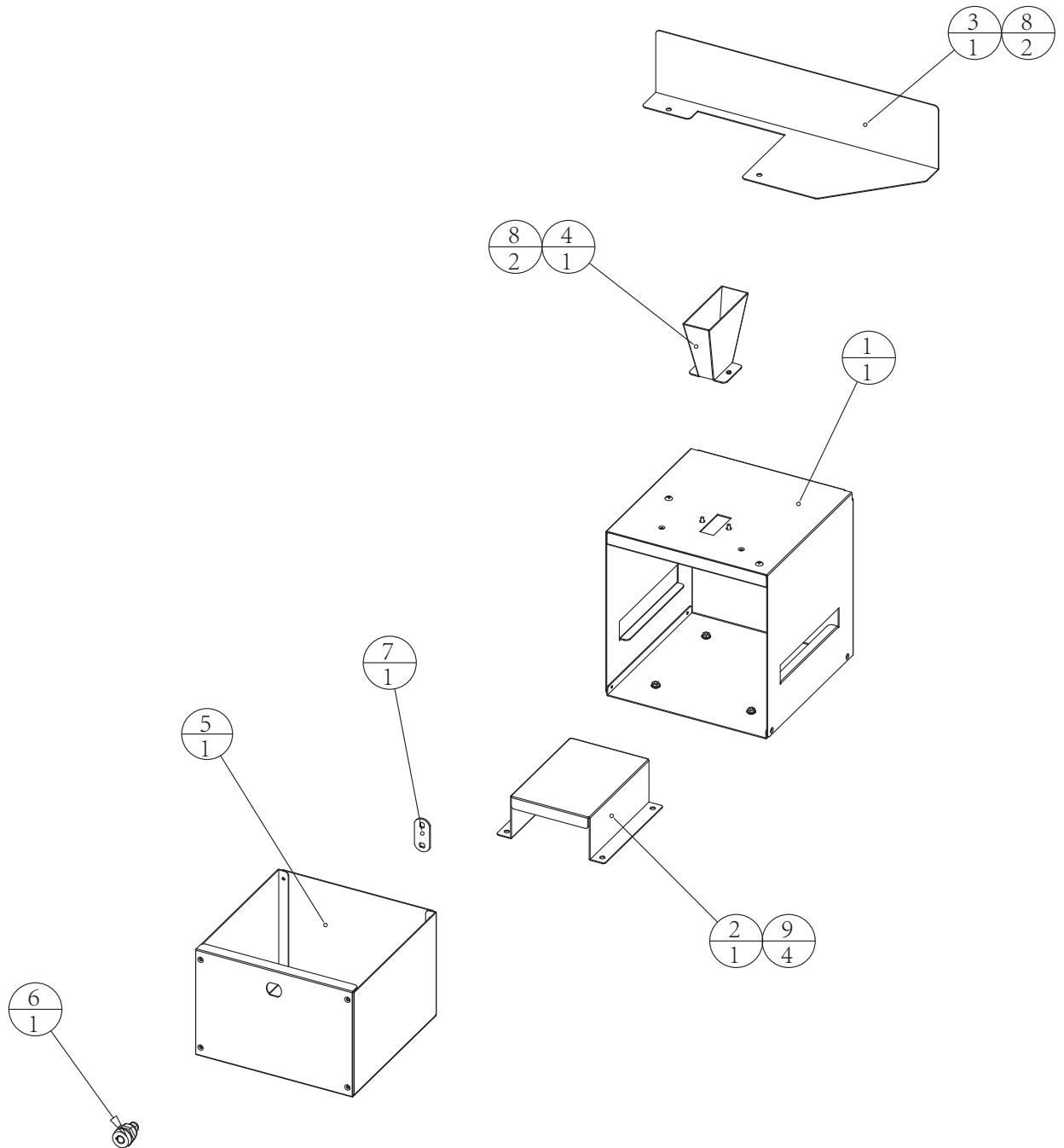

| | | | | | |
|----|-------------|------------------------------------|---------------------------------|-----|--------------|
| 9 | | Hexagon nut with flange | M4 (color-coating) | 4 | 1.6.LM204013 |
| 8 | | Cross flat-head screw | M4*6 (chrome plated) | 4 | 1.6.LS240012 |
| 7 | | Straight locking-plate, short | 4cm(No.003) | 1 | 1.4.SJ500020 |
| 6 | | Miscellaneous lock (including key) | B17 miscellaneous (height 17mm) | 1 | 1.4.SJ220060 |
| 5 | KC-0103A03 | Cashbox | | 1 | |
| 4 | KC-0103A02 | Coin-slide | | 1 | |
| 3 | PP-0103A03 | Sealing-plate on cashbox | SPCC-1.0T | 1 | |
| 2 | PP-0103A02 | Cash-box pad-iron | SPCC-1.2T | 1 | |
| 1 | PP-0103A01 | Cash-box frame | | 1 | |
| SN | Drawing No. | Name | Materials/specifications | Qty | Note |

6.3.4 Prize-lane components (PP-0104000)

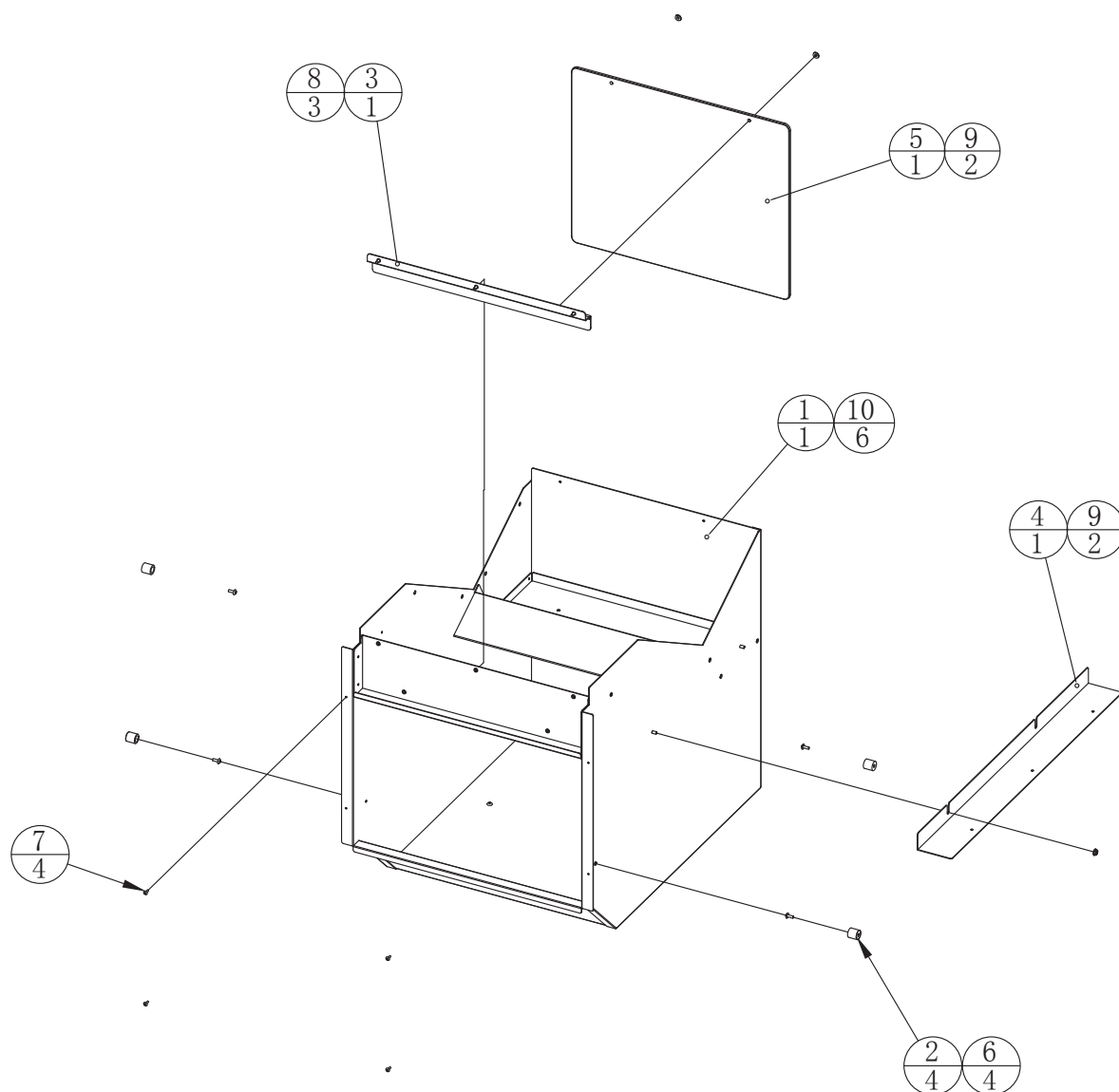

| | | | | | |
|----|-------------|---------------------------|--------------------------|-----|--------------|
| 10 | | Hexagon flat-head screw | M4*8 (chrome plated) | 6 | 1.6.LS140032 |
| 9 | | Hexagon nut with flange | M4 (color coating) | 4 | 1.6.LM204013 |
| 8 | | Cross flat-head screw | M4*8 (chrome plated) | 3 | 1.6.LS240022 |
| 7 | | Cross flat-head screw | M3*8 (chrome plated) | 4 | 1.6.LS230032 |
| 6 | | Cross flat-head screw | M4*10 (chrome plated) | 4 | 1.6.LS241012 |
| 5 | PP-0104D01 | Prize outlet-door | PMMA-5.0T | 1 | |
| 4 | PP-0104A03 | Bottom left sealing-plate | SPCC-1.2T | 1 | |
| 3 | PP-0104A02 | Prize outlet-hinge | | 1 | |
| 2 | KC-0104C01 | Prize door-mat | Rubber spring | 4 | |
| 1 | PP-0104A01 | Prize slideway | | 1 | |
| SN | Drawing No. | Name | Materials/specifications | Qty | Note |

6.3.5 Prize-outlet mask components (PP-0105000)

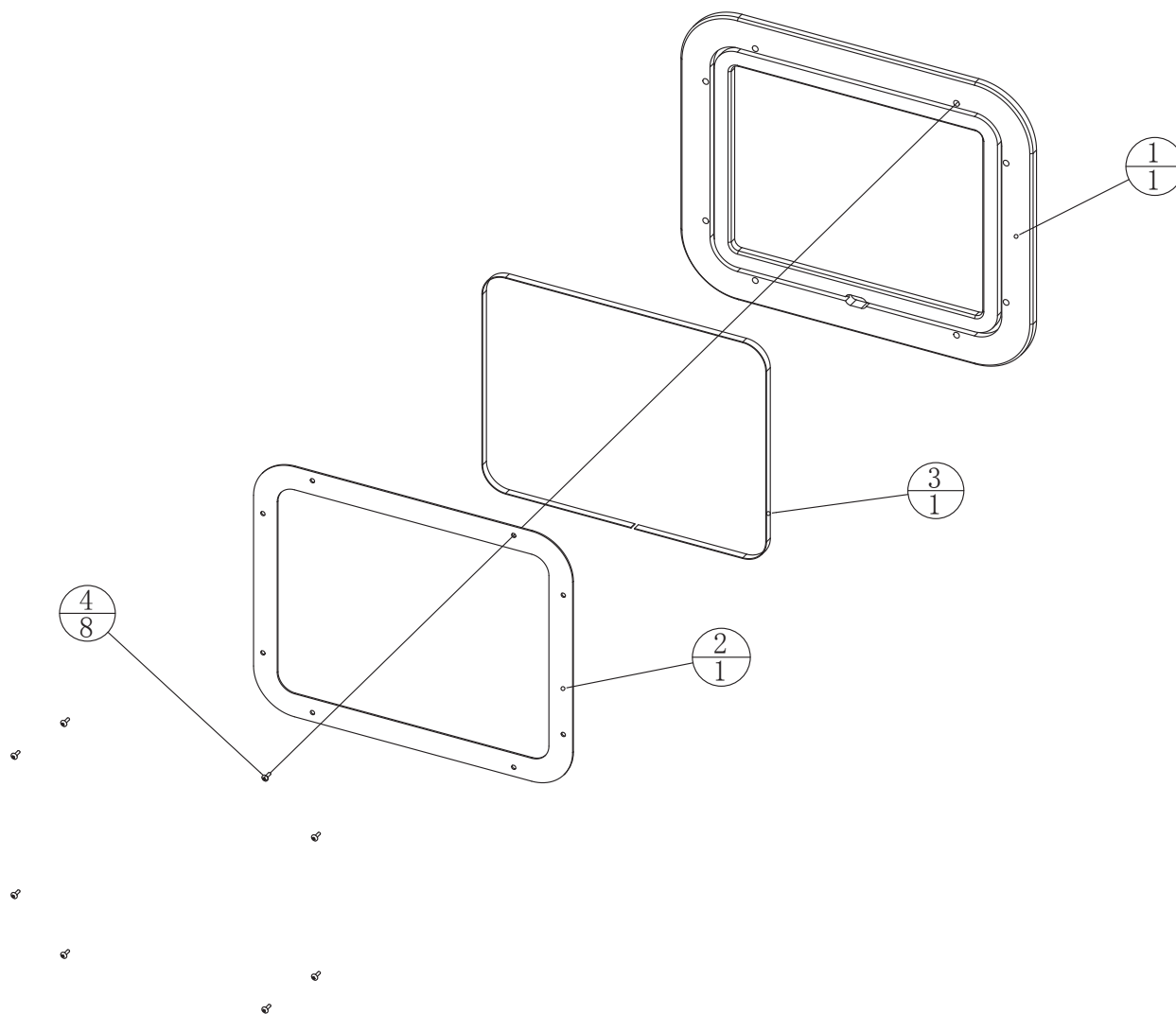

| | | | | | |
|----|-------------|-------------------------|---------------------------|-----|--------------|
| 4 | | Hexagon flat-head screw | M4*12 (chrome plated) | 8 | 1.6.LS141022 |
| 3 | | 5050 soft lamp-bar | DC12V RGB60 lamp L=1350mm | 1 | 1.4.ZM9E0086 |
| 2 | PP-0105A01 | Prize outlet iron | SPCC-2.0T | 1 | |
| 1 | PP-0105D01 | Prize-outlet lamp acryl | white gourd PMMA-15.0T | 1 | |
| SN | Drawing No. | Name | Materials/specifications | Qty | Note |

6.3.6 PCB-box components (PP-0106000)

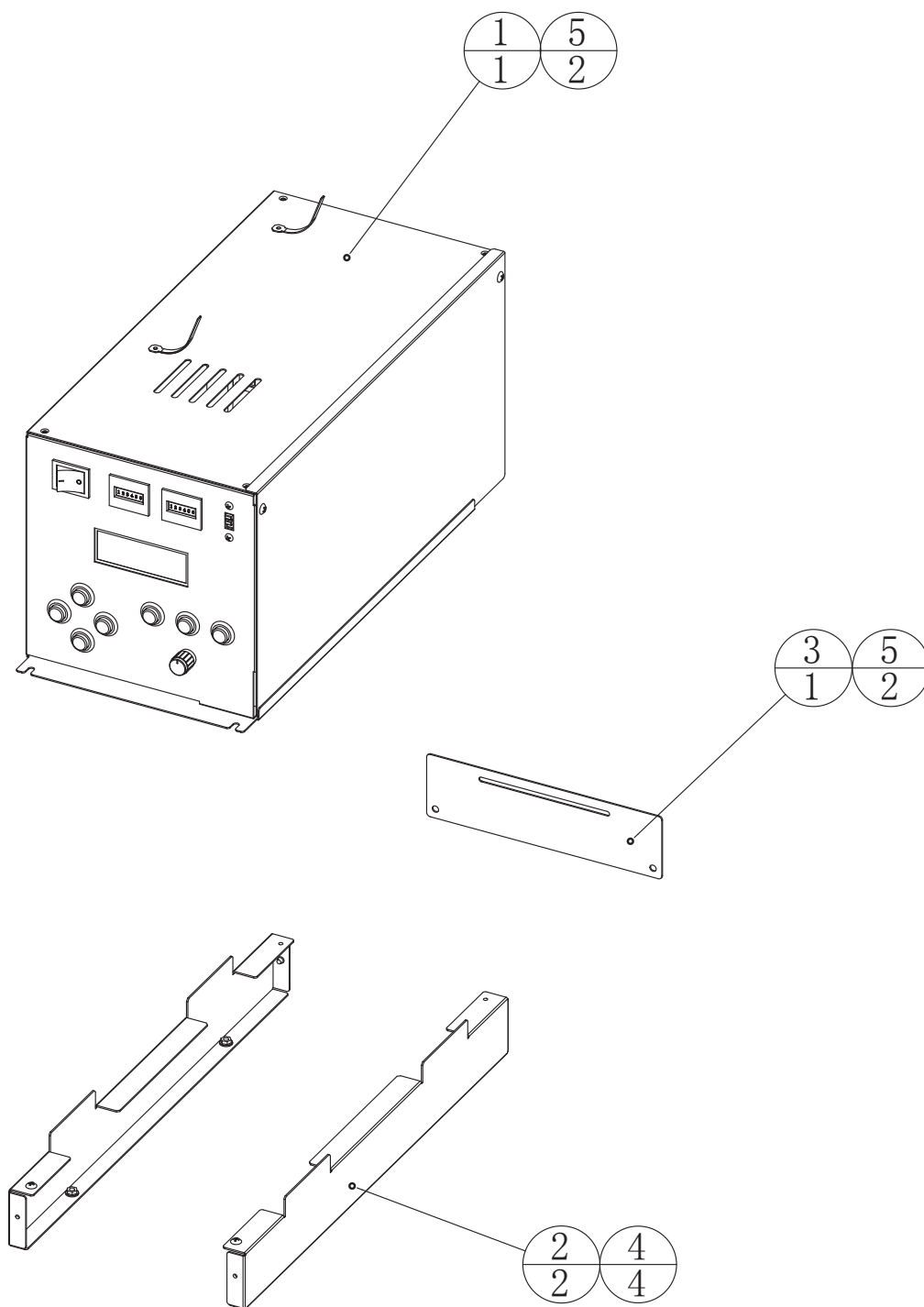

| | | | | | |
|----|--------------|--------------------------|--------------------------|-----|----------------|
| 5 | | Cross flat-head screw | M4*6 (chrome plated) | 4 | 1. 6. LS240012 |
| 4 | | Hexagon nut with flange | M4 (color coating) | 4 | 1. 6. LM204013 |
| 3 | PP-0106A04 | No.2 PCB supporting-iron | SPCC-1.2T | 1 | |
| 2 | PP-0106A03 | No.1 PCB supporting-iron | SPCC-1.2T | 2 | |
| 1 | PP-0106000-A | PCB components | | 1 | |
| SN | Drawing No. | Name | Materials/specifications | Qty | Note |

6.3.6.1 PCB components (PP-0106000-A)

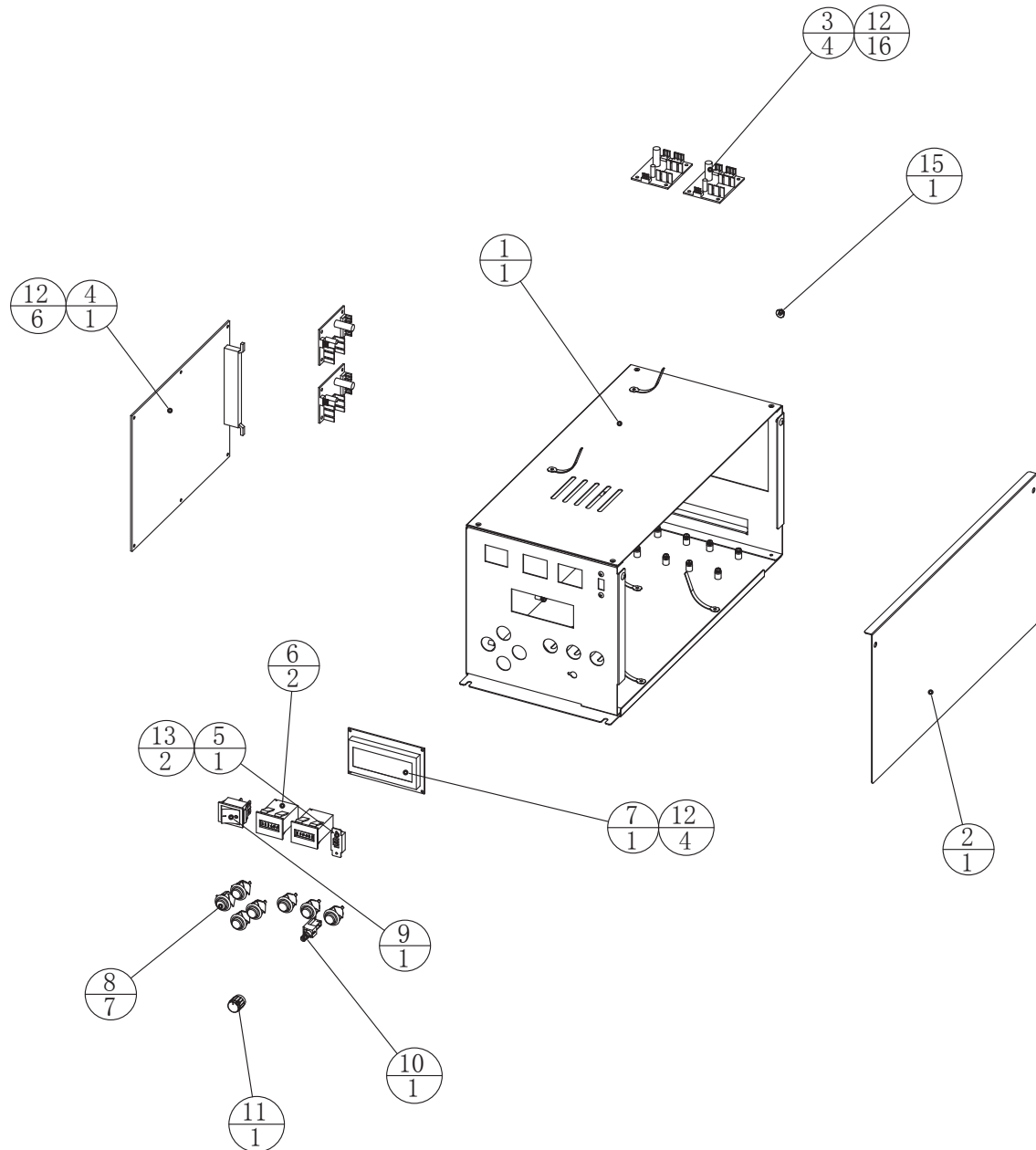

| | | | | | |
|----|-------------|---------------------------|--------------------------|-----|-----------------|
| 15 | | Hexagon nut with flange | M4 (color coating) | 1 | 1.6.LM204013 |
| 14 | | Cross flat-head screw | M4*6 (chrome plated) | 2 | 1.6.LS240012 |
| 13 | | Cross flat-head screw | M3*8 (chrome plated) | 2 | 1.6.LS230032 |
| 12 | | Cross round-head screw | M3*6 (chrome plated) | 26 | 1.6.LS830012 |
| 11 | | Potentiometer knob | Φ13mm | 1 | 1.4.VR201310 |
| 10 | | Volume VR components | VR-B10KΩ | 1 | 1.4.VR160010 |
| 9 | | The ship type switch | 4P KCD7-2211N | 1 | 1.4.SW604010 |
| 8 | | Circular card-type button | Sanwa red SDP-103C-22RB | 7 | 1.4.AJ500012# |
| 7 | | LCD screen | TM204A-1(with terminal) | 1 | 1.4.XS402022 |
| 6 | | Counter | DC 12V | 2 | 1.4.JS100020 |
| 5 | | Slide switch | 3A/252V-6A/125V | 1 | 1.4.SW900010 |
| 4 | | Main board | | 1 | 1.3.WA36A00010# |
| 3 | | Motor driver-board | WL_KC_MotorDrive_V1.0 | 4 | 1.4.IC901137 |
| 2 | PP-0106A02 | PCB cover-plate | SPCC-1.0T | 1 | |
| 1 | PP-0106A01 | PCB fixed-iron | SPCC-1.0T | 1 | |
| SN | Drawing No. | Name | Materials/specifications | Qty | Note |

6.3.7 Glass components on both sides (PP-0107000)

Note:

Padding with battens and foam:1.0*10MM

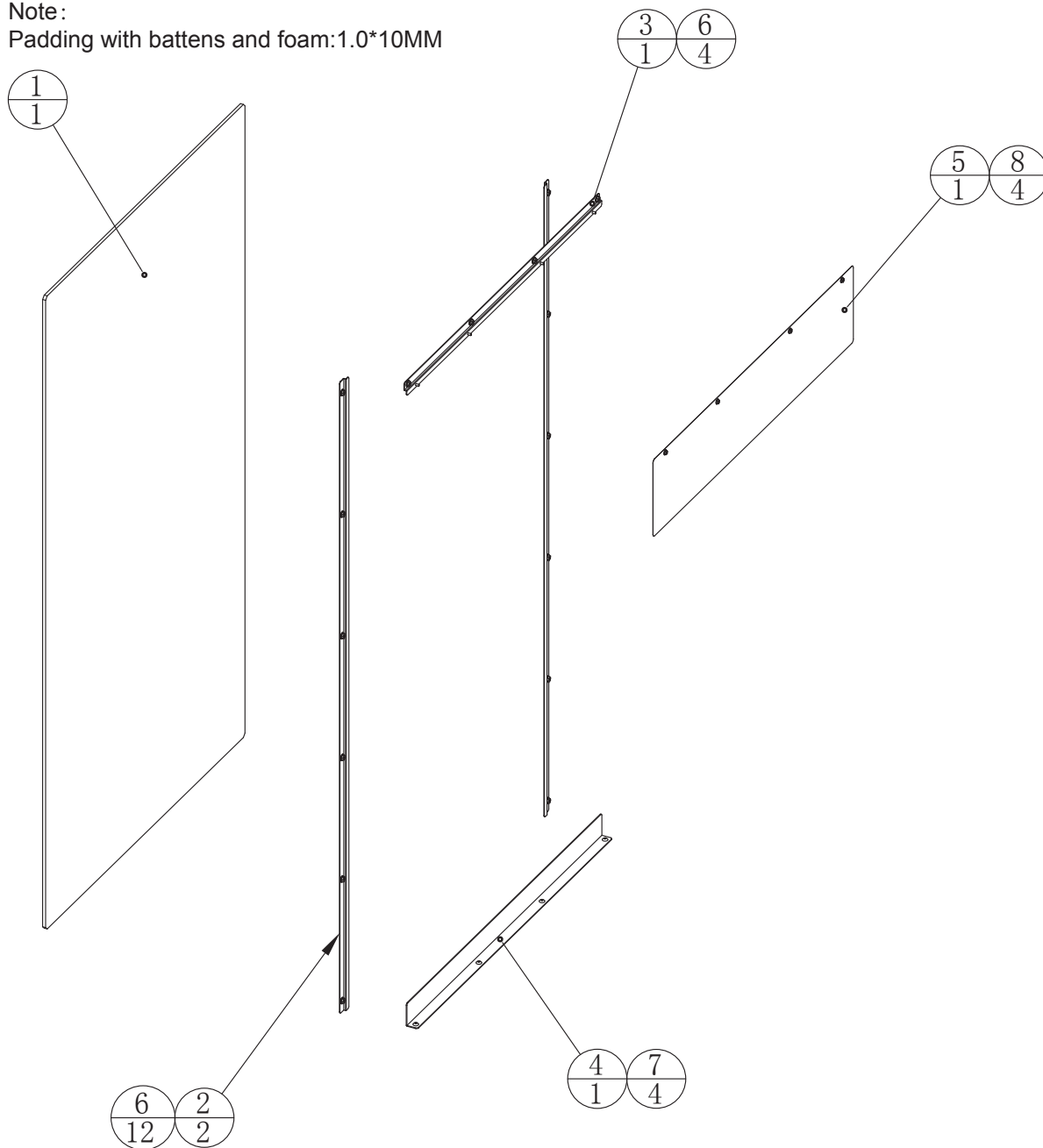

| | | | | | |
|----|-------------|-----------------------------|--------------------------|-----|--------------|
| 8 | | Hexagon nut with flange | M3 (color-coating) | 4 | 1.6.LM203013 |
| 7 | | Hexagonal flat-head screw | M4*6 (chrome plated) | 4 | 1.6.LS140012 |
| 6 | | Hexagon nut with flange | M4 (color-coating) | 16 | 1.6.LM204013 |
| 5 | PP-0107D01 | Two-sided sticker board | PVC-0.2T | 1 | |
| 4 | PP-0107A03 | Glass layering 3 | SPCC-1.2T | 1 | |
| 3 | PP-0107A02 | Glass layering 2 | SPCC-1.0T | 1 | |
| 2 | PP-0107A01 | Glass layering 1 | SPCC-1.0T | 2 | |
| 1 | PP-0107C01 | Bilateral transparent plate | Glass | 1 | |
| SN | Drawing No. | Name | Materials/specifications | Qty | Note |

6.3.8 TILT components (PP-0108000)

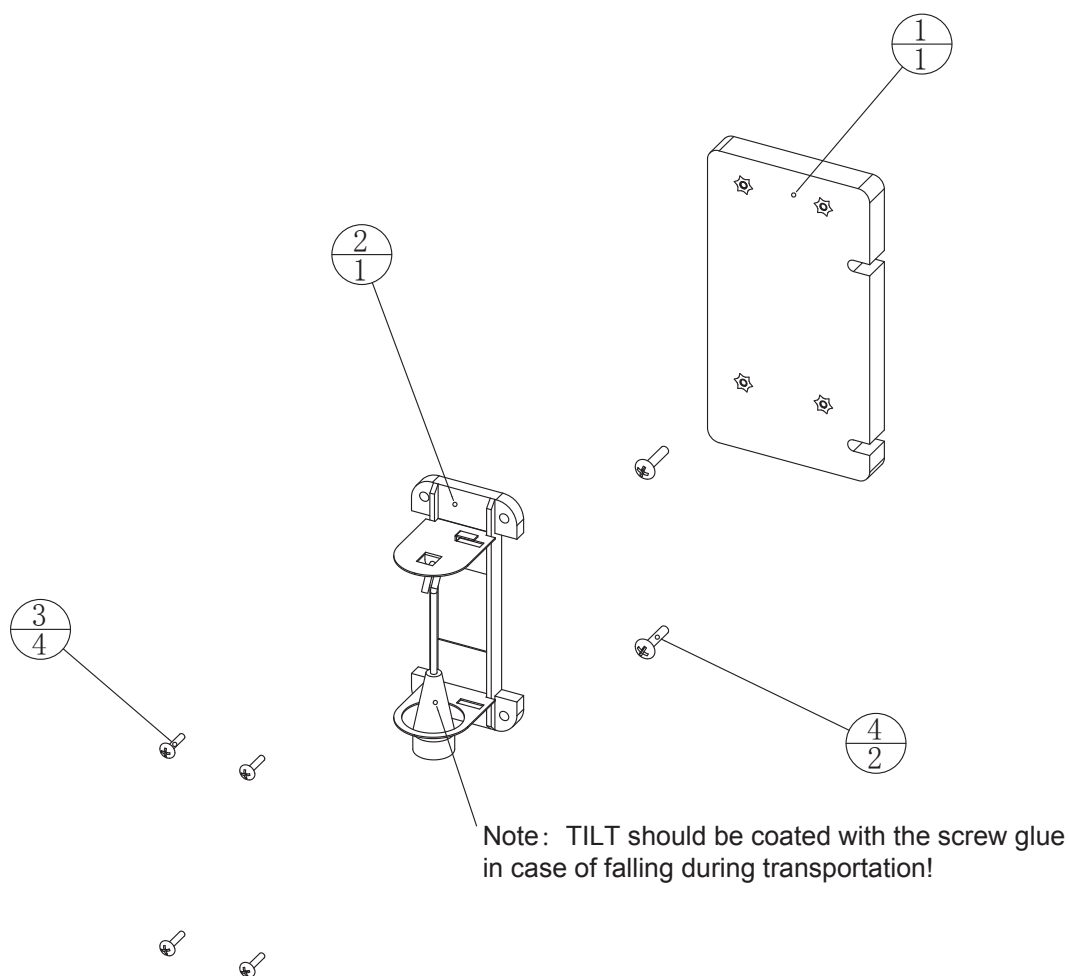

TILT adjust guide

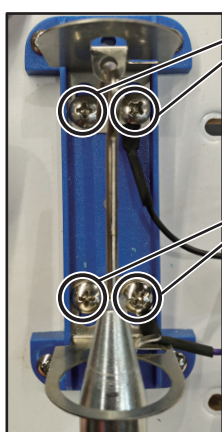

1. Loosen the 2 screws at "A" and move the iron plate to adjust the distance of 0~6mm to adjust the accuracy of the TILT.
2. Loosen the 2 screws at "B" and move the swing hammer to adjust the distance of 0~6mm to adjust the accuracy of the TILT.
3. The accuracy of the TILT in the picture is already at the highest state.

| | | | | | |
|----|-------------|-----------------------|--------------------------|-----|--------------|
| 4 | | Cross flat-head screw | M4*16 (chrome plated) | 2 | 1.6.LS241032 |
| 3 | | Cross flat-head screw | M3*12 (chrome plated) | 4 | 1.6.LS231022 |
| 2 | | TILT | For KWM188 machine | 1 | 1.4.QT200010 |
| 1 | PP-0108B01 | TILT board | MDF-12.0T | 1 | |
| SN | Drawing No. | Name | Materials/specifications | Qty | Note |

6.3.9 Eyelet sensor components (PP-0109000)

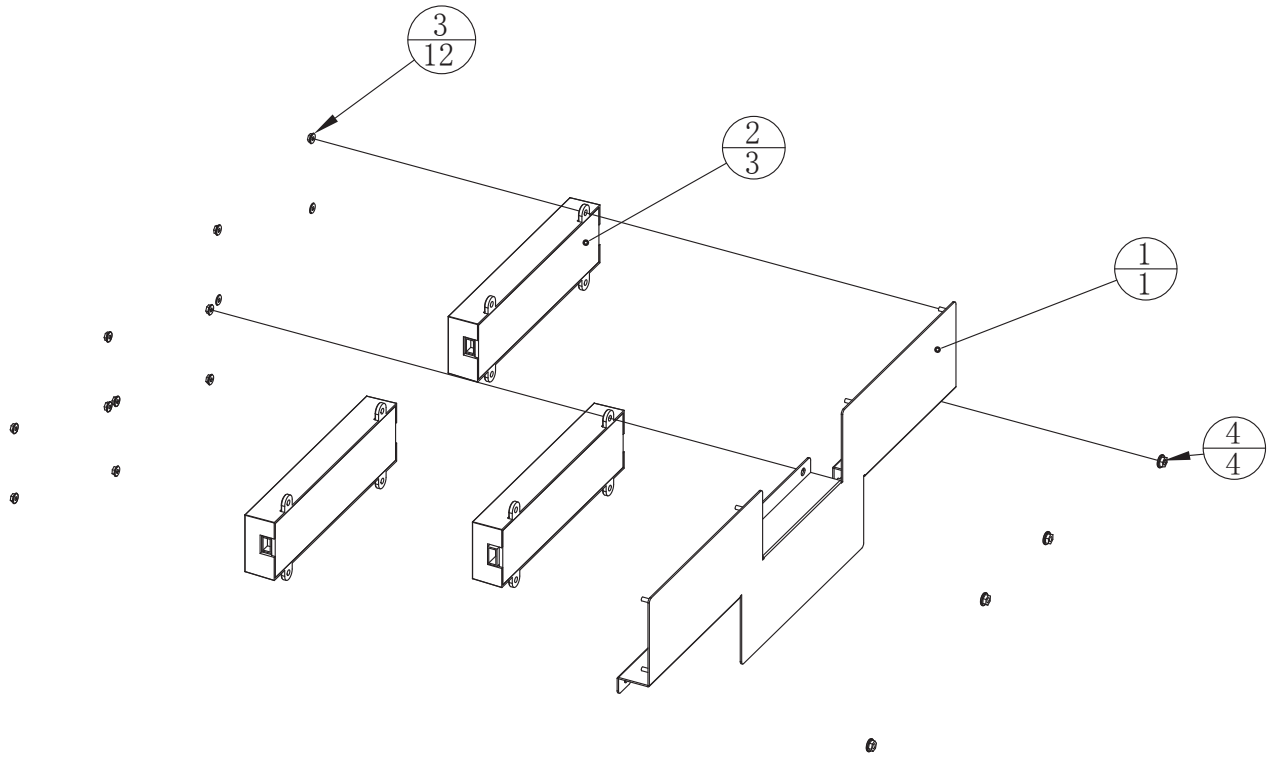

| | | | | | |
|----|--------------|----------------------------|--------------------------|-----|--------------|
| 4 | | hexagon nut with flange | M4 (color coating) | 4 | 1.6.LM204013 |
| 3 | | hexagon nut with flange | M3 (color coating) | 12 | 1.6.LM203013 |
| 2 | PP-0109A01-A | Optical-eye box components | | 3 | |
| 1 | PP-0109A01 | Eyelet fixing-iron | SPCC-1.2T | 1 | |
| SN | Drawing No. | Name | Materials/specifications | Qty | Note |

6.3.9.1 Optical-eye box (PP-0109000-A)

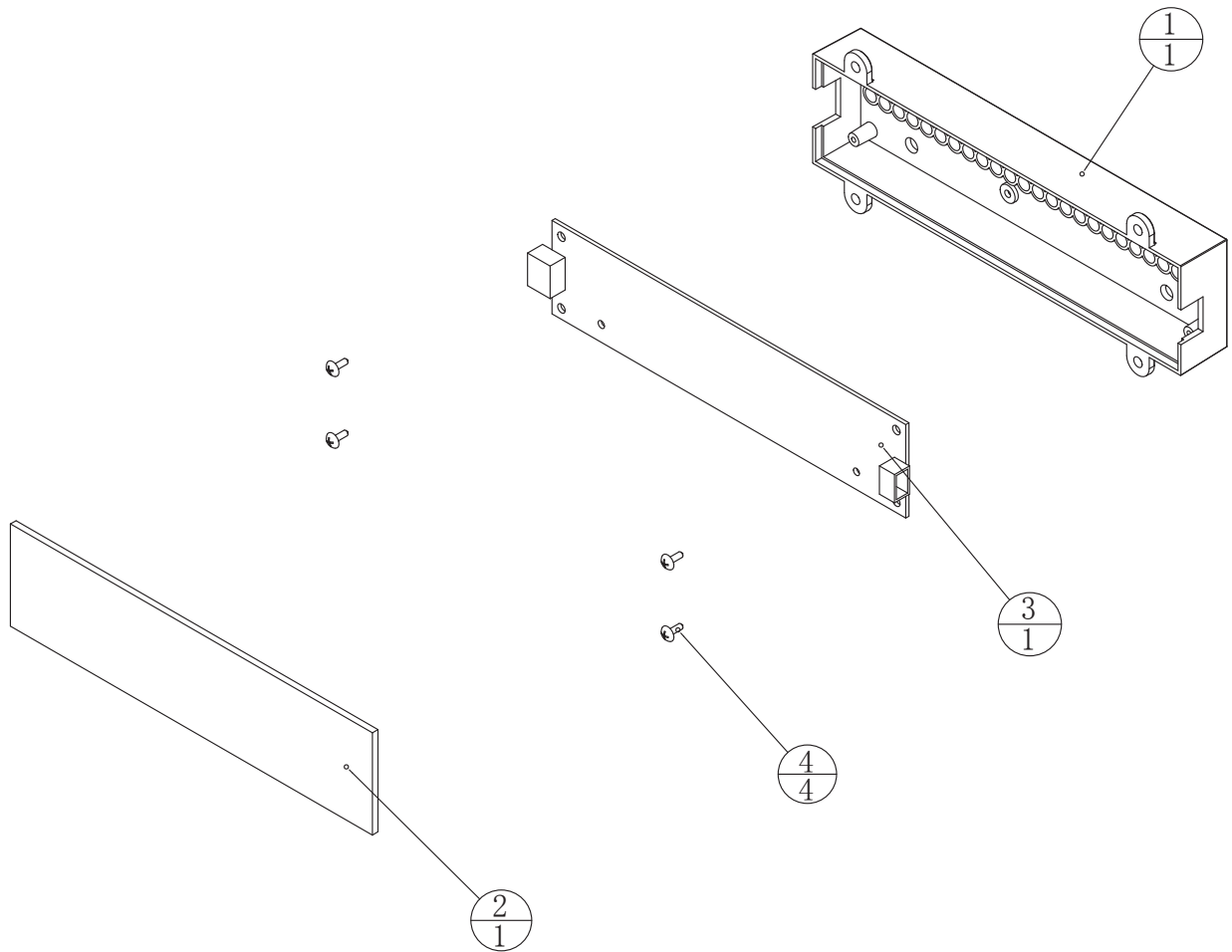

| | | | | | |
|----|-------------|------------------------------------|--------------------------|-----|--------------|
| 4 | | Cross flat-head self-tapping screw | M3*8 (chrome plated) | 4 | 1.6.LS330022 |
| 3 | | Optical-eye plate | WL_PP_EYE_V1.0 | 1 | 1.4.IC901142 |
| 2 | PP-0109C02 | Optical-eye cover-plate | Black ABS | 1 | |
| 1 | PP-0109C01 | Optical-eye box | Black ABS | 1 | |
| SN | Drawing No. | Name | Materials/specifications | Qty | Note |

6.3.10 Inner supporting-iron components (PP-0110000)

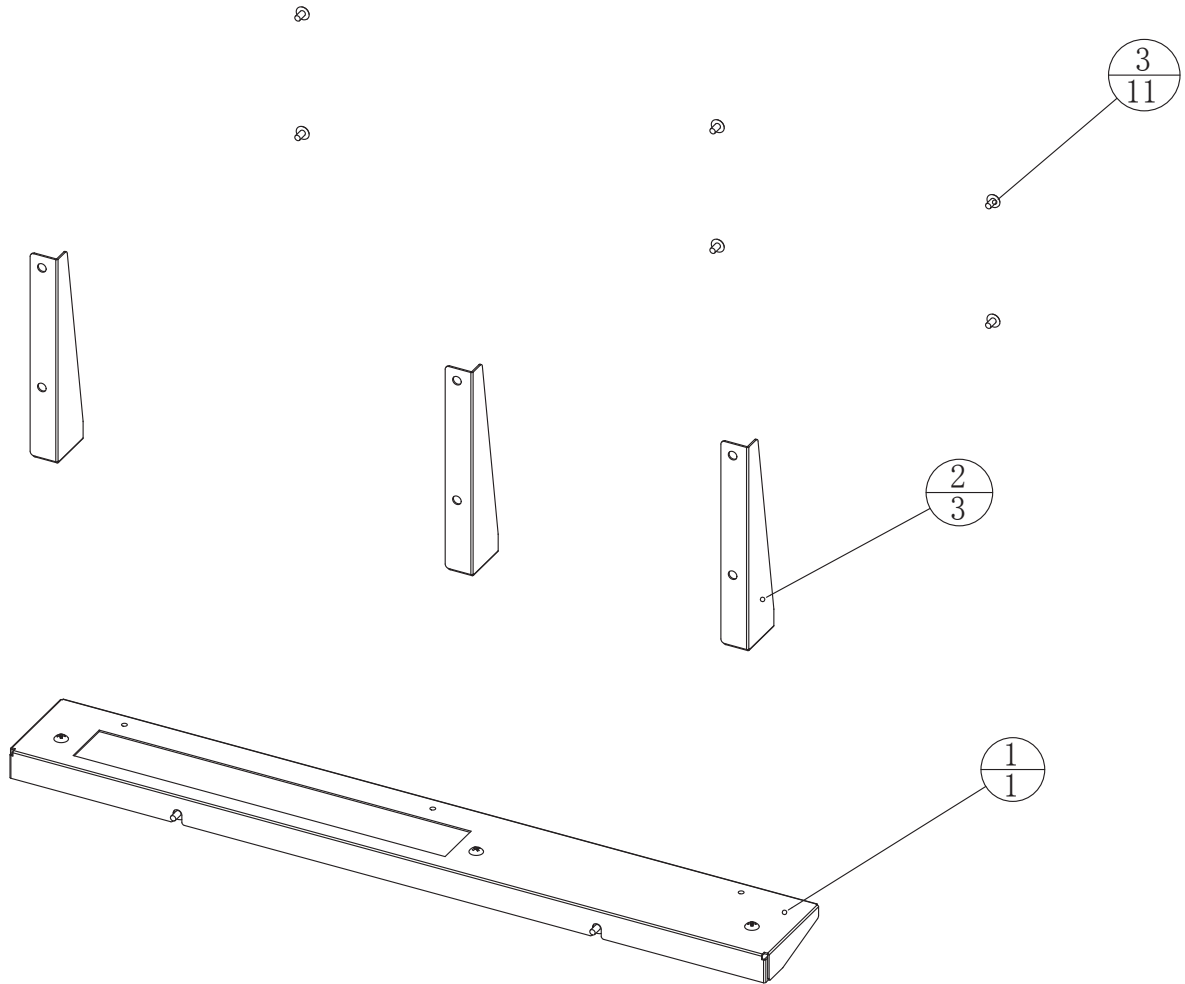

| | | | | | |
|----|-------------|---|--------------------------|-----|--------------|
| 3 | | Cross flat-head screw | M5*8 (chrone plated) | 11 | 1.6.LS250012 |
| 2 | PP-0110A02 | No.2 supporting-iron in the control panel | SPCC-1.2T | 3 | |
| 1 | PP-0110A01 | No.1 supporting-iron in the control panel | SPCC-1.2T | 1 | |
| SN | Drawing No. | Name | Materials/specifications | Qty | Note |

6.3.11 Bottom sealing-plate components (PP-0111000)

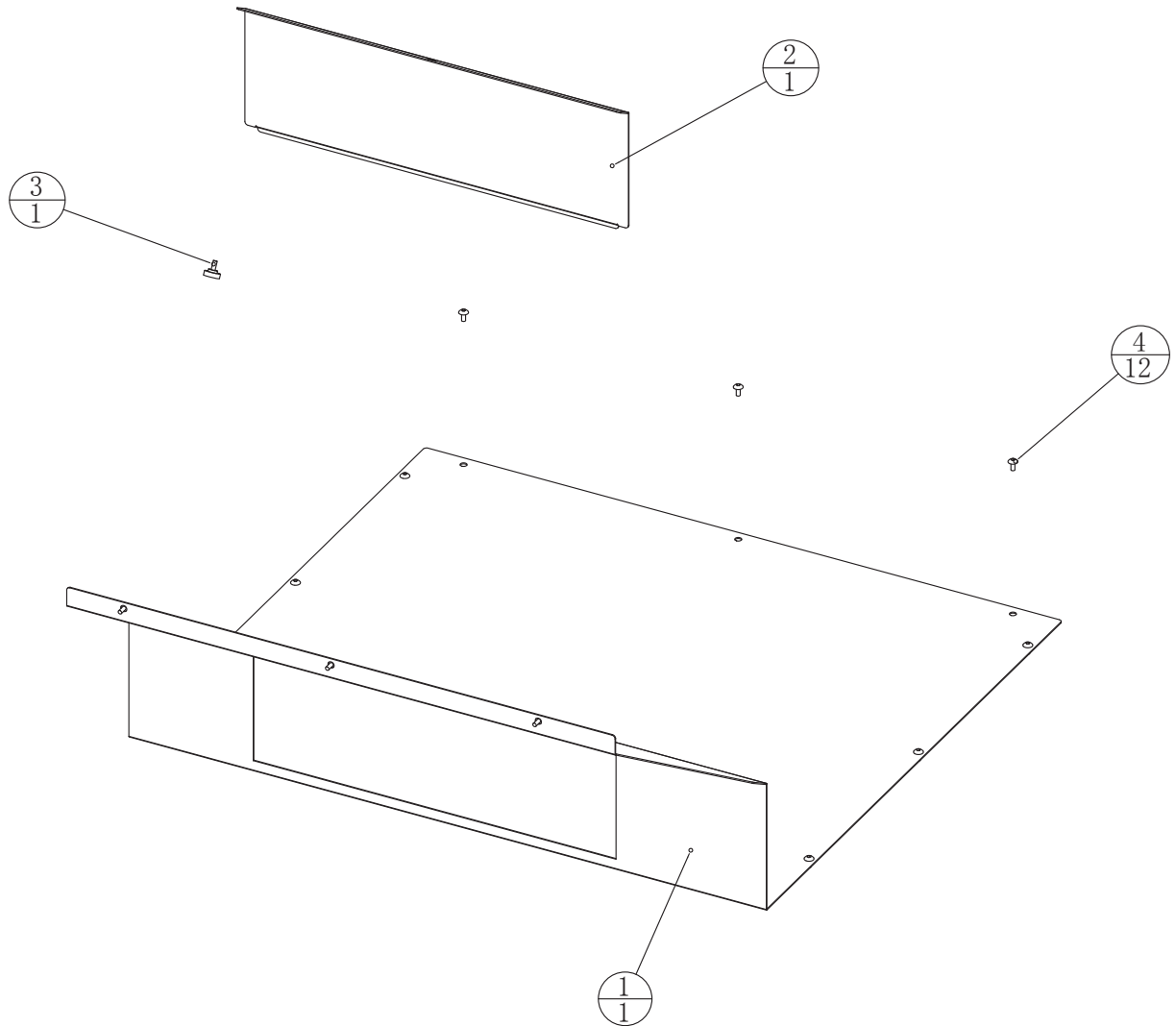

| | | | | | |
|----|-------------|-----------------------------------|--------------------------|-----|--------------|
| 4 | | Hexagon flat-head screw | M4*8 (chrome plated) | 12 | 1.6.LS140032 |
| 3 | | Plastic-head screw | M4*8 (white) | 1 | 1.6.LSU40800 |
| 2 | PP-0111A02 | Lower cover-plate with hole-cover | SPCC-1.0T | 1 | |
| 1 | PP-0111A01 | Lower cover-plate | SPCC-1.0T | 1 | |
| SN | Drawing No. | Name | Materials/specifications | Qty | Note |

6.3.12 Prize sealing-plate door components (PP-0112000)

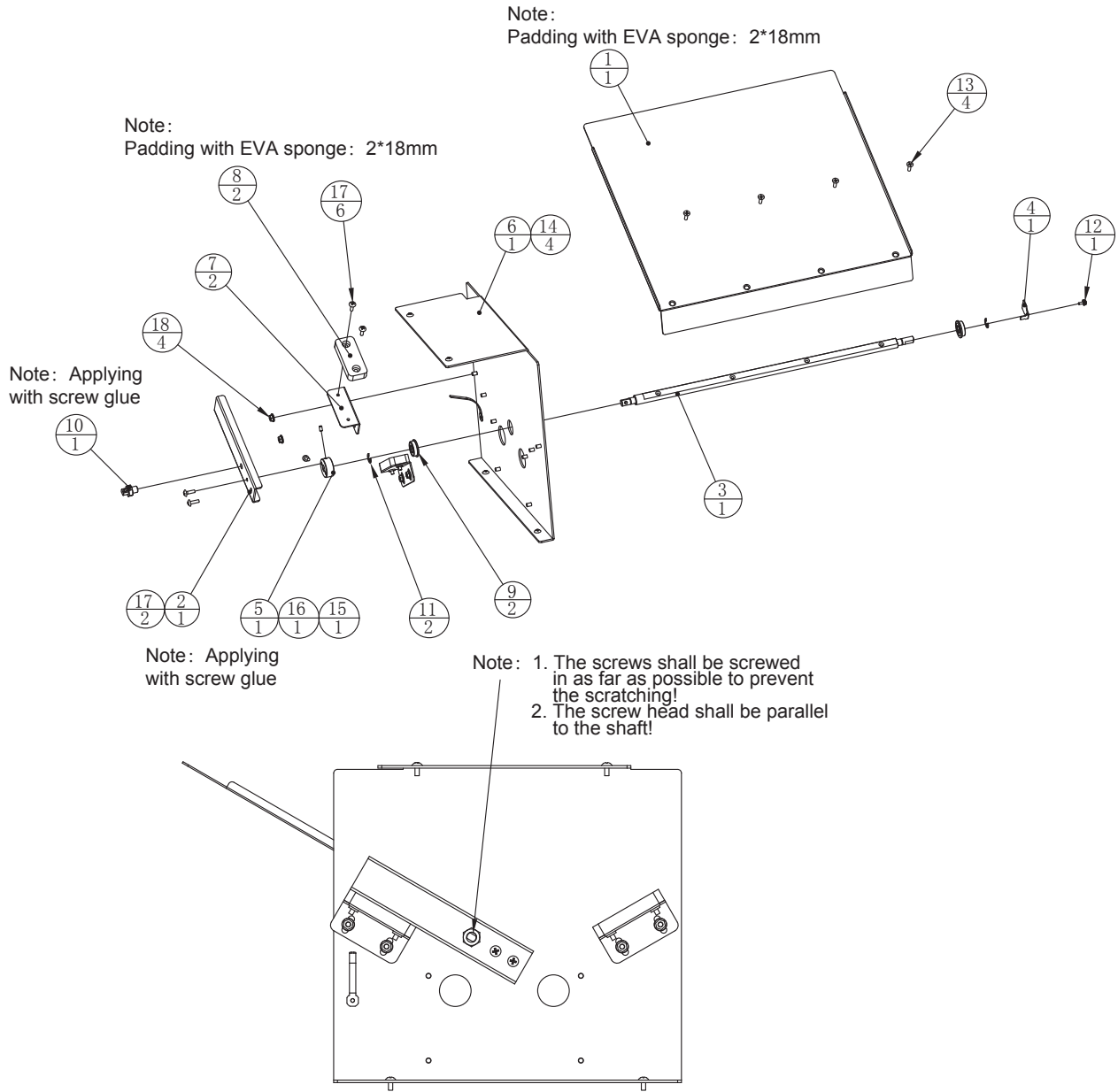

| | | | | | |
|----|-------------|---|--------------------------|-----|---------------|
| 18 | | Hexagon nut with flange | M4 (color coating) | 4 | 1.6.LM204013 |
| 17 | | Cross flat-head screw | M4*12 (chrome plated) | 6 | 1.6.LS241022 |
| 16 | | Hexagon socket-head cap screw | M4*10 (stainless steel) | 1 | 1.6.LSF41015 |
| 15 | | Headless socket screw | M4*6 (black coating) | 1 | 1.6.LST40011# |
| 14 | | Cross flat-head screw | M4*8 (chrome plated) | 4 | 1.6.LS240022 |
| 13 | | Cross countersunk-head screw | M4*12 (black coating) | 4 | 1.6.LSC41021 |
| 12 | | Cross round-head screw | M3*6 (chrome plated) | 1 | 1.6.LS830012 |
| 11 | | Split washer (e-buckle) | M6(black coating) | 2 | 1.6.DQ106011 |
| 10 | | Brace for spring stretch | AIPOZ8-20 | 1 | 1.4.HY010031 |
| 9 | | Flange bearing | F698ZZ | 2 | 1.4.ZC000066 |
| 8 | PP-0112A08 | Lower cushion | | 2 | |
| 7 | PP-0112A07 | Sealing-plate gasket | SPCC-1.5T | 2 | |
| 6 | PP-0112A06 | Left-turn shaft seat-iron for outlet door | SPCC-2.0T | 1 | |
| 5 | PP-0112A05 | Retaining ring for outlet door | 45 | 1 | |
| 4 | PP-0112A04 | Right outlet-sensing baffle | SPCC-1.0T | 1 | |
| 3 | PP-0112A03 | Outlet door-seal shaft | 45 | 1 | |
| 2 | PP-0112A02 | No.2 outlet spring hanging-iron | SPCC-2.0T | 1 | |
| 1 | PP-0112A01 | Outlet sealing-door | SPCC-1.2T | 1 | |
| SN | Drawing No. | Name | Materials/specifications | Qty | Note |

6.3.13 Low-voltage power module (PP-0113000)

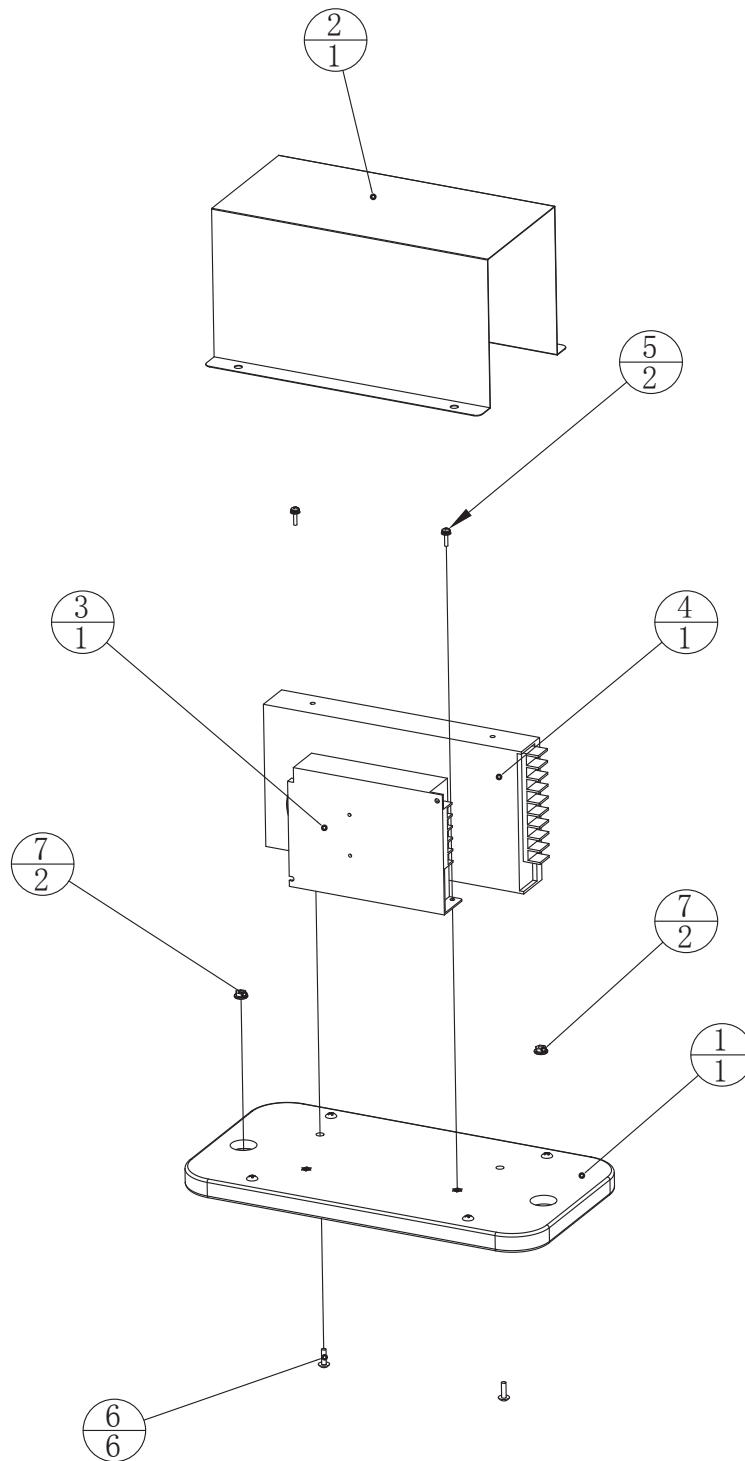

| | | | | | |
|----|-------------|----------------------------|--------------------------|-----|--------------|
| 7 | | Hexagon nut with flange | M4 (color coating) | 2 | 1.6.LM204013 |
| 6 | | Cross flat-head screw | M4*12 (chrome plated) | 6 | 1.6.LS241022 |
| 5 | | Cross round-head screw | M3*10 (chrome plated) | 2 | 1.6.LS831012 |
| 4 | | Power box | K10L-S300D12+5 | 1 | 1.4.DY020100 |
| 3 | | Power box | K06L-U100S24 | 1 | 1.4.DY020011 |
| 2 | PP-0113D01 | Cover for power box | PVC-0.5T | 1 | |
| 1 | PP-0113B01 | Fixing-board for power box | MDF-15.0T | 1 | |
| SN | Drawing No. | Name | Materials/specifications | Qty | Note |

6.3.14 Door-closing motor components (PP-0114000)

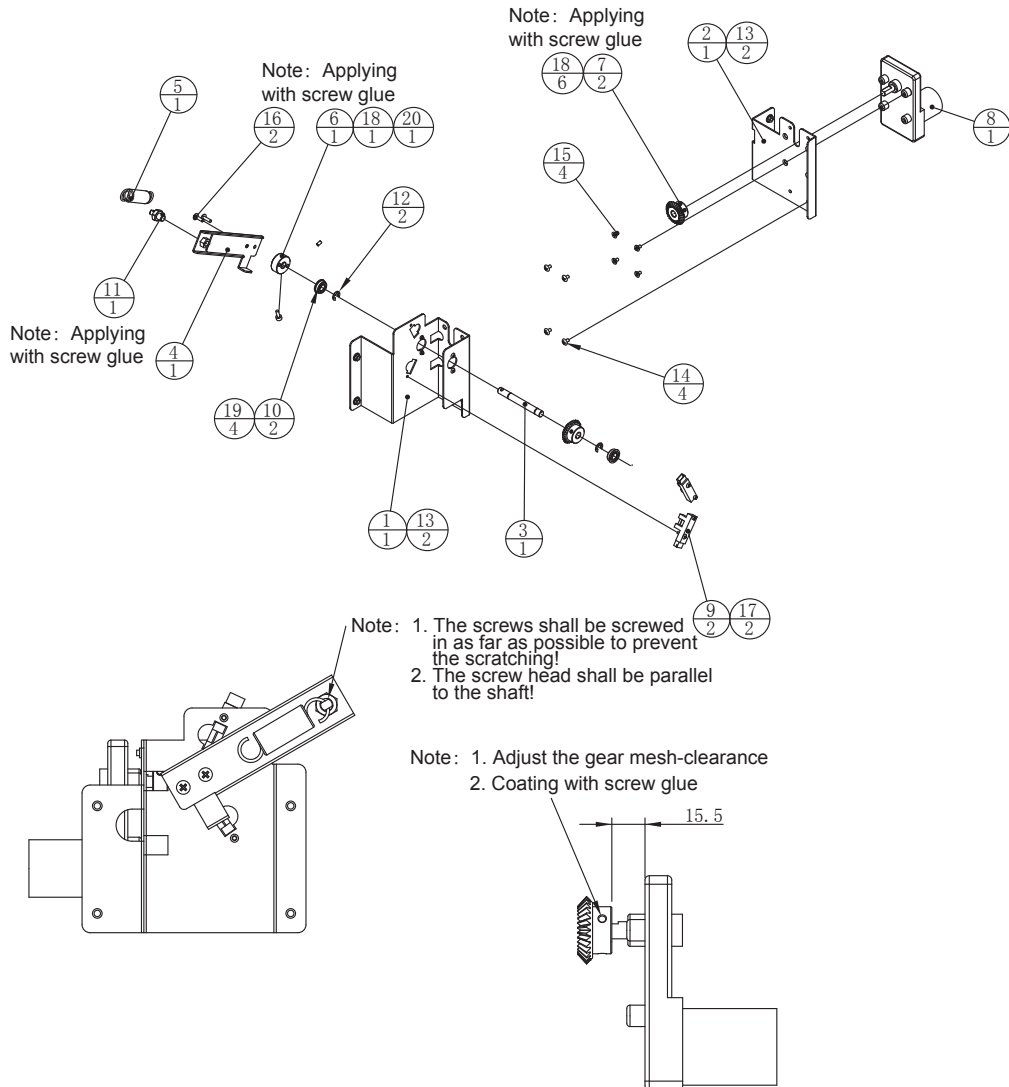

| | | | | | |
|----|-------------|---------------------------------|--------------------------|-----|---------------|
| 20 | | Hexagon socket-head cap screw | M4*10 (stainless steel) | 1 | 1.6.LSF41015 |
| 19 | | Cross flat-head screw | M3*6 (chrome plated) | 4 | 1.6.LS230022 |
| 18 | | Headless socket screw | M4*6 (black coating) | 7 | 1.6.LST40011# |
| 17 | | Cross flat-head screw | M3*12 (chrome plated) | 2 | 1.6.LS231022 |
| 16 | | Cross flat-head screw | M4*12 (chrome plated) | 2 | 1.6.LS241022 |
| 15 | | Cross countersunk-head screw | M4*6 (galvanized) | 4 | 1.6.LSC40014 |
| 14 | | Cross flat-head screw | M4*6 (chrome plated) | 4 | 1.6.LS240012 |
| 13 | | Hexagon nut with flange | M4 (color coating) | 4 | 1.6.LM204013 |
| 12 | | Split washer (e-buckle) | M6(black coating) | 2 | 1.6.DQ106011 |
| 11 | | Brace for spring stretch | AIPOZ8-20 | 1 | 1.4.HY010031 |
| 10 | | Flange bearing | LF-1680HH | 2 | 1.4.ZC000065 |
| 9 | | Sensor | KI1300-AA07LF | 2 | 5.4.WECHE0004 |
| 8 | | Motor | TG-85E-BG-200-CKA, 24V | 1 | 1.4.MD100029 |
| 7 | KC-0704A02 | Bevel gear | Q235 | 2 | |
| 6 | PP-0112A05 | Outlet-door fixing-ring | 45 | 1 | |
| 5 | PP-0114A05 | Sealing-door tension spring | SUS304-WPB | 1 | |
| 4 | PP-0114A04 | No.1 outlet spring hanging-iron | SPCC-1.5T | 1 | |
| 3 | PP-0114A03 | Outlet-motor shaft | 45 | 1 | |
| 2 | PP-0114A02 | No.2 motor iron for prize-door | SPCC-1.5T | 1 | |
| 1 | PP-0114A01 | No.1 motor iron for prize-door | SPCC-1.5T | 1 | |
| SN | Drawing No. | Name | Materials/specifications | Qty | Note |

6.4 Control-panel components (PP-0200000)

Note: The joystick ball shall be coated with screw glue.

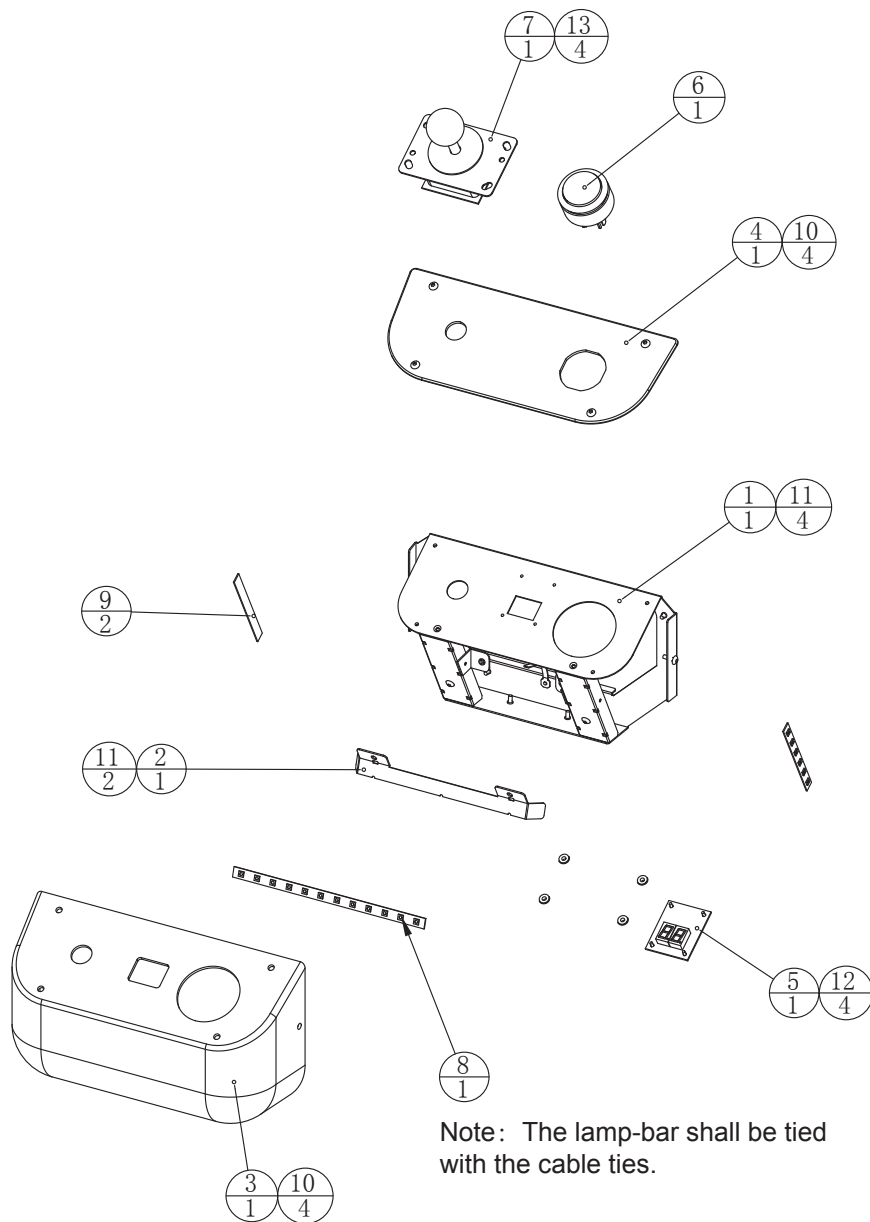

Note: The lamp-bar shall be tied with the cable ties.

| | | | | | |
|----|-------------|---|---|-----|--------------|
| 13 | | Hexagon nut with flange | M4 (color coating) | 4 | 1.6.LM204013 |
| 12 | | Cross round-head screw | M3*6 (chrome plated) | 4 | 1.6.LS830012 |
| 11 | | Hexagon flat-head screw | M4*8 (chrome plated) | 6 | 1.6.LS140032 |
| 10 | | Hexagon flat-head screw | M4*12 (chrome plated) | 8 | 1.6.LS141022 |
| 9 | | 5050 soft lamp-bar | DC12V RGB60 lamp L=100MM | 2 | 1.4.ZM9E0512 |
| 8 | | 5050 soft lamp-bar | DC12V RGB60 lamp L=200MM | 1 | 1.4.ZM9E0015 |
| 7 | | Rocker with lamps | JS-EPCG-BU-45-CB (Blue, In all directions) | 1 | 1.4.YG100031 |
| 6 | | Round button with lamp (including lamp holder) | BLC-TNWA-PW-B-CR | 1 | 1.4.AJ104043 |
| 5 | | Digital tube sheet | WL_KC_7SEG_V1.0 | 1 | 1.4.ZJ030691 |
| 4 | KC-0200D01 | Acryl on control-panel | PC-3.0T | 1 | |
| 3 | KC-0200C01 | Plastic cover for control-panel | white gourd PMMA | 1 | |
| 2 | KC-0200A02 | Lamp-bar iron on control-panel | SPCC-1.2T | 1 | |
| 1 | KC-0200A01 | Fixed iron for control-panel | | 1 | |
| SN | Drawing No. | Name | Materials/specifications | Qty | Note |

6.5 Coin-door components (PP-0300000)

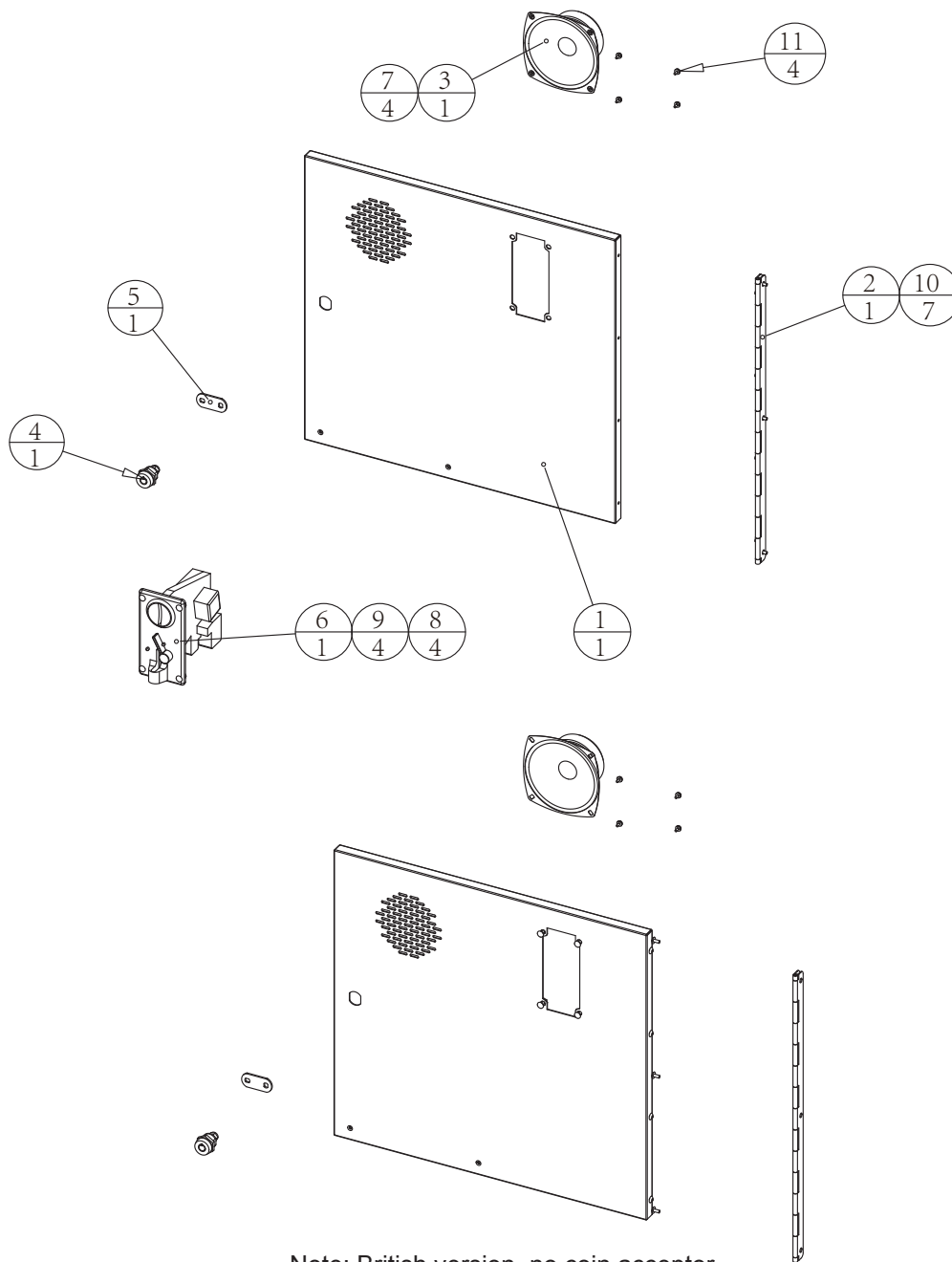

Note: British version, no coin acceptor

| | | | | | |
|----|-------------|--|---------------------------|-----|--------------|
| 10 | | Phillips round head three combination screws | M3*6 (chrome plated) | 4 | 1.6.LS830012 |
| 10 | | Cross flat-head screw | M4*6 (chrome plated) | 7 | 1.6.LS240012 |
| 9 | | Carriage bolt | M4*12 (chrome plated) | 4 | 1.6.LSP41022 |
| 8 | | Hexagon nut with flange | M4 (color coating) | 4 | 1.6.LM204013 |
| 7 | | Hexagon nut with flange | M3 (color coating) | 4 | 1.6.LM203013 |
| 6 | | Electronic side-vertical coin-acceptor | TW-130B | 1 | 1.4.TB100030 |
| 5 | | Straight locking-plate, short | 4cm(No.003) | 1 | 1.4.SJ500020 |
| 4 | | Same-type lock | B17 No.6687 (Height 17mm) | 1 | 1.4.SJ120140 |
| 3 | | Round loudspeaker | 4' 8Ω/15W | 1 | 1.4.YS104040 |
| 2 | PP-0300A02 | Coin-door hinge | | 1 | |
| 1 | PP-0300A01 | Coin-door | | 1 | |
| SN | Drawing No. | Name | Materials/specifications | Qty | Note |

6.6 Large door-frame components (PP-0400000)

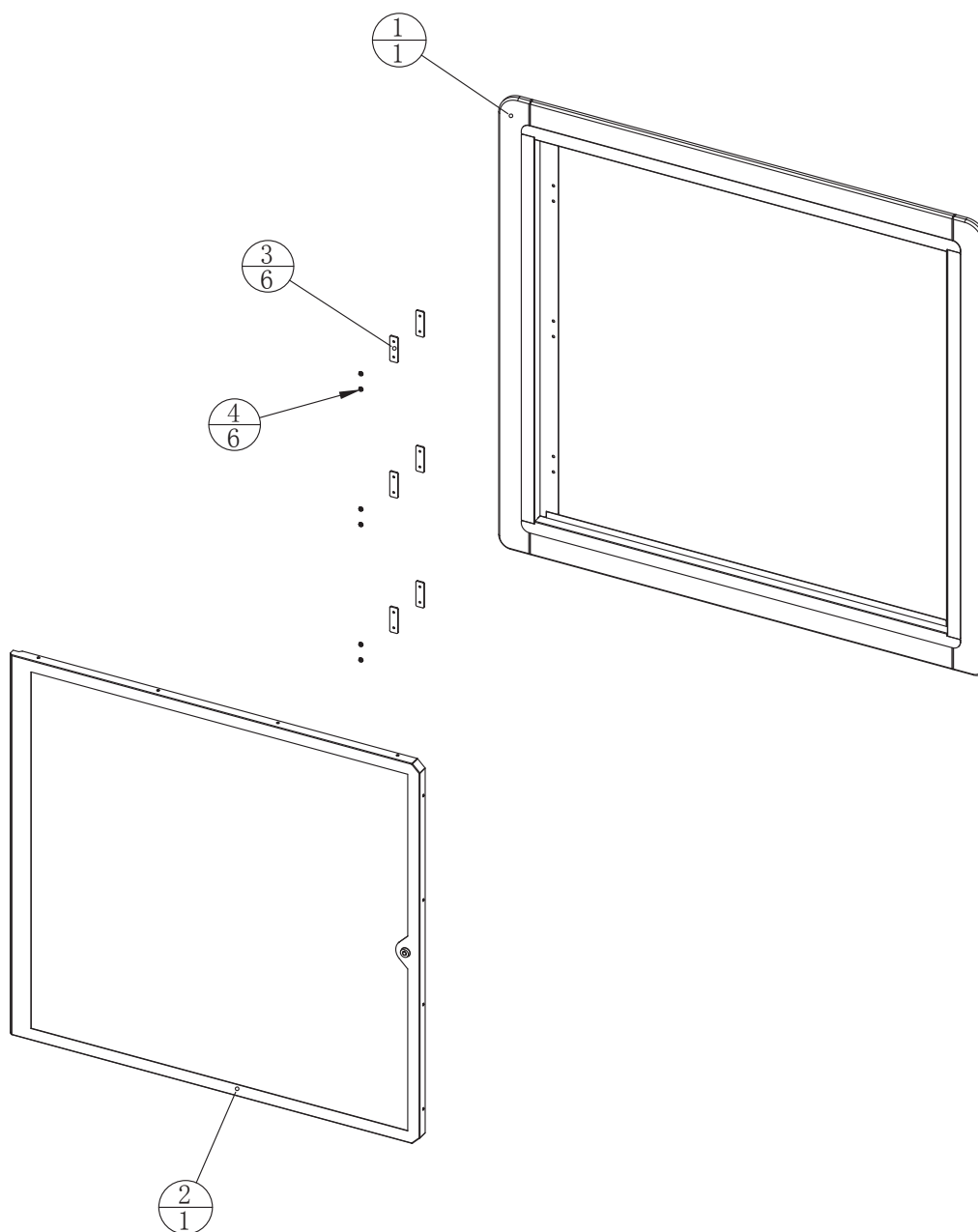

| | | | | | |
|----|-------------|-------------------------------|--------------------------|-----|--------------|
| 4 | | Hexagon nut with flange | M4 (color coating) | 6 | 1.6.LM204013 |
| 3 | PP-0400A01 | Hinge shim-plate | SPCC-3.0T | 6 | |
| 2 | PP-0402000 | Acrylic door-components | | 1 | |
| 1 | PP-0401000 | Door-frame acrylic components | | 1 | |
| SN | Drawing No. | Name | Materials/specifications | Qty | Note |

6.6.1 Door-frame acrylic components (PP-0401000)

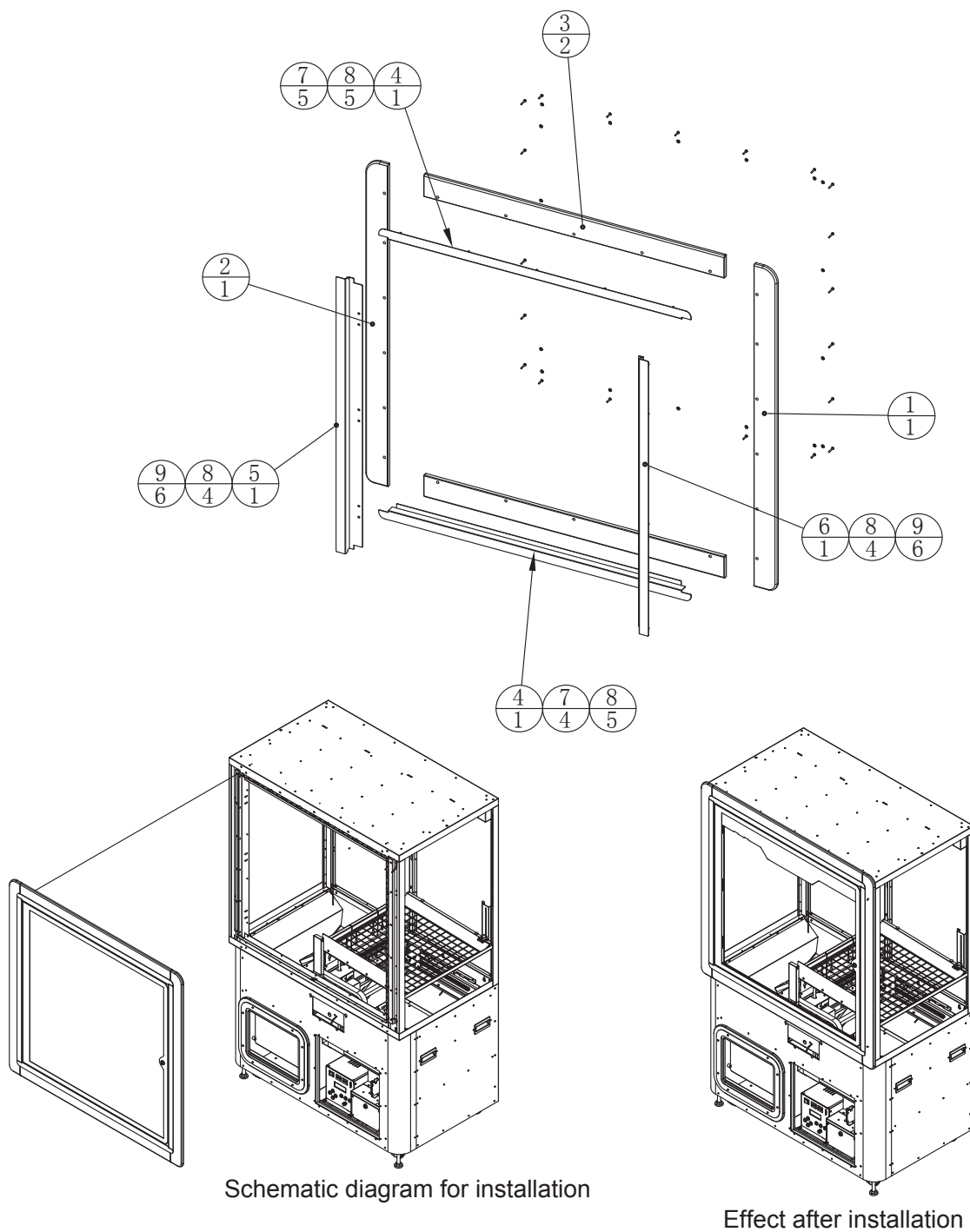

| | | | | | |
|----|-------------|----------------------------------|--------------------------|-----|--------------|
| 9 | | Hexagon flat-head screw | M4*25 (chrome plated) | 12 | 1.6.LS142022 |
| 8 | | Hexagon nut with flange | M4 (color coating) | 18 | 1.6.LM204013 |
| 7 | | Hexagon flat-head screw | M4*20 (chrome plated) | 9 | 1.6.LS142012 |
| 6 | PP-0401A03 | No.4 outside-frame pressing-iron | SPCC-1.5T | 1 | |
| 5 | PP-0401A02 | No.3 outside-frame pressing-iron | SPCC-1.5T | 1 | |
| 4 | KC-0401A01 | No.1 outside-frame pressing-iron | SPCC-1.5T | 2 | |
| 3 | KC-0401D02 | Acryl on the door | white gourd PMMA-15.0T | 2 | |
| 2 | KC-0401D03 | Acryl on the left-door | white gourd PMMA-15.0T | 1 | |
| 1 | KC-0401D01 | Acryl on the right-door | white gourd PMMA-15.0T | 1 | |
| SN | Drawing No. | Name | Materials/specifications | Qty | Note |

6.6.2 Large acrylic-door components (PP-0402000)

Note: The adjustable end shall face up for adjusting.

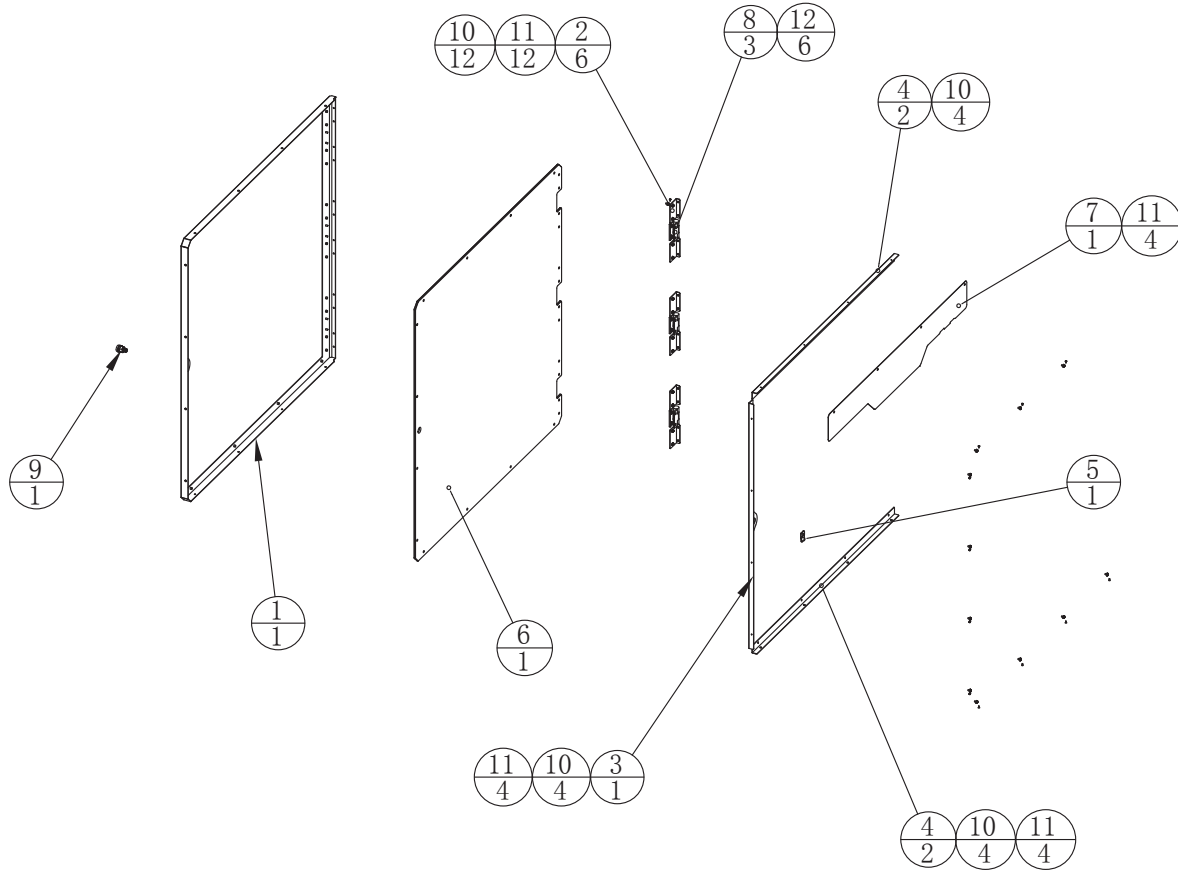

| | | | | | |
|----|-------------|-------------------------------|---------------------------|-----|--------------|
| 12 | | Hexagon nut with flange | M4 (color coating) | 6 | 1.6.LM204013 |
| 11 | | Cross round-head screw | M4*6 (chrome plated) | 24 | 1.6.LS840012 |
| 10 | | Cross countersunk-head screw | M3*6 (chrome plated) | 24 | 1.6.LSC30022 |
| 9 | | Same-type lock | B17 No.6687 (height 17mm) | 1 | 1.4.SJ120140 |
| 8 | | Adjustable-damp hinge | HHPTFB8 | 3 | 1.4.HY010040 |
| 7 | PP-0402D02 | Front-door hanging-sticker | PVC-0.2T | 1 | |
| 6 | PP-0402D01 | Large transparent door-plank | PMMA-5.0T | 1 | |
| 5 | KC-0402A07 | Lock plate | SPCC-2.0T | 1 | |
| 4 | KC-0402A05 | No.3 door-frame pressing-iron | SPCC-1.5T | 2 | |
| 3 | KC-0402A03 | No.1 door-frame pressing-iron | SPCC-1.5T | 1 | |
| 2 | PP-0402A02 | No.2 door-frame pressing-iron | SPCC-1.5T | 6 | |
| 1 | PP-0402A01 | Door-frame pressing-iron | SPCC-1.5T | 1 | |
| SN | Drawing No. | Name | Materials/specifications | Qty | Note |

6.7 General moving part components (PP-0500000)

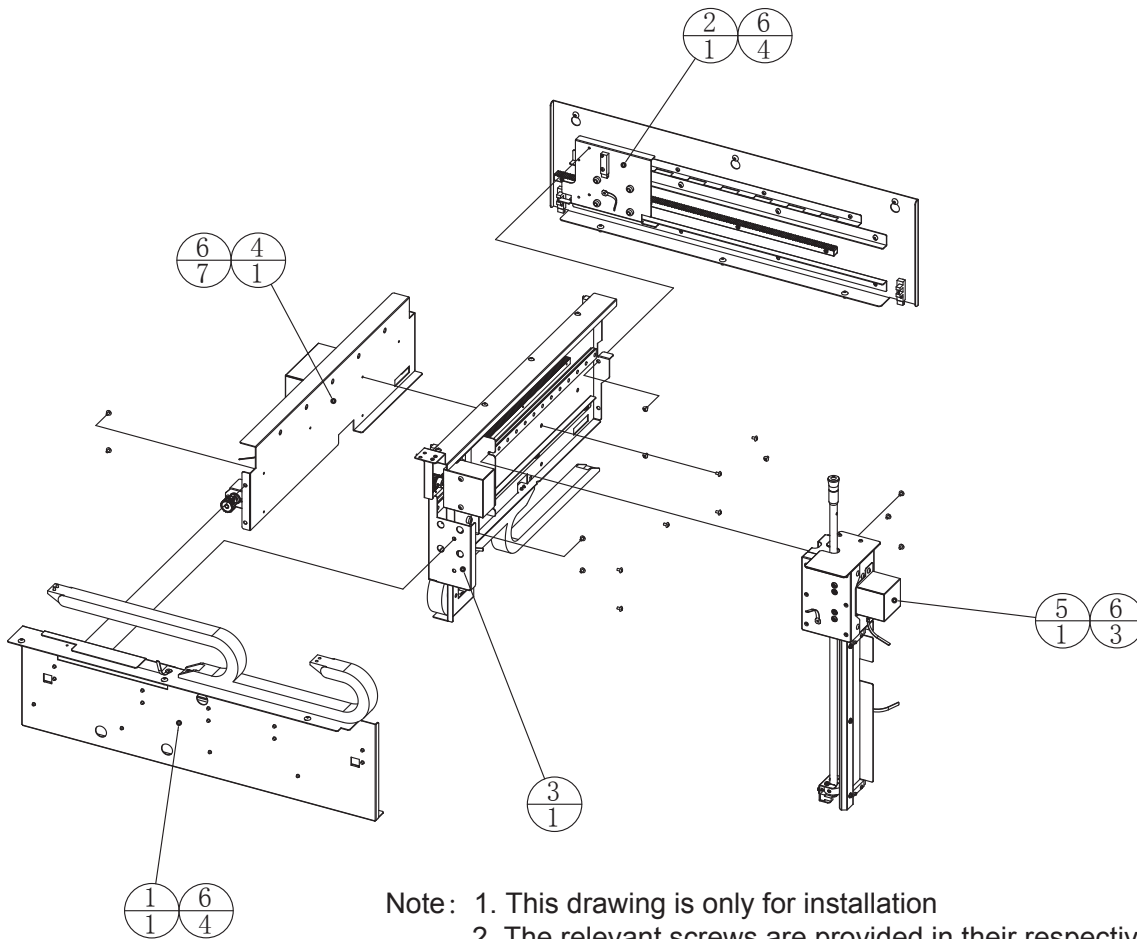

Note: 1. This drawing is only for installation
 2. The relevant screws are provided in their respective components

| | | | | | |
|----|-------------|---|--------------------------|-----|--------------|
| 6 | | Cross flat-head screw | M4*6 (chrome plated) | 18 | 1.6.LS240012 |
| 5 | PP-0505000 | Push-rod components | | 1 | |
| 4 | PP-0504000 | Horizontally-moving motor-components | | 1 | |
| 3 | PP-0503000 | Longitudinally-moving rail-components | | 1 | |
| 2 | PP-0502000 | Horizontally-moving rear-rail components | | 1 | |
| 1 | PP-0501000 | Horizontally-moving front-rail components | | 1 | |
| SN | Drawing No. | Name | Materials/specifications | Qty | Note |

6.7.1 Horizontally-moving front-rail components (PP-0501000)

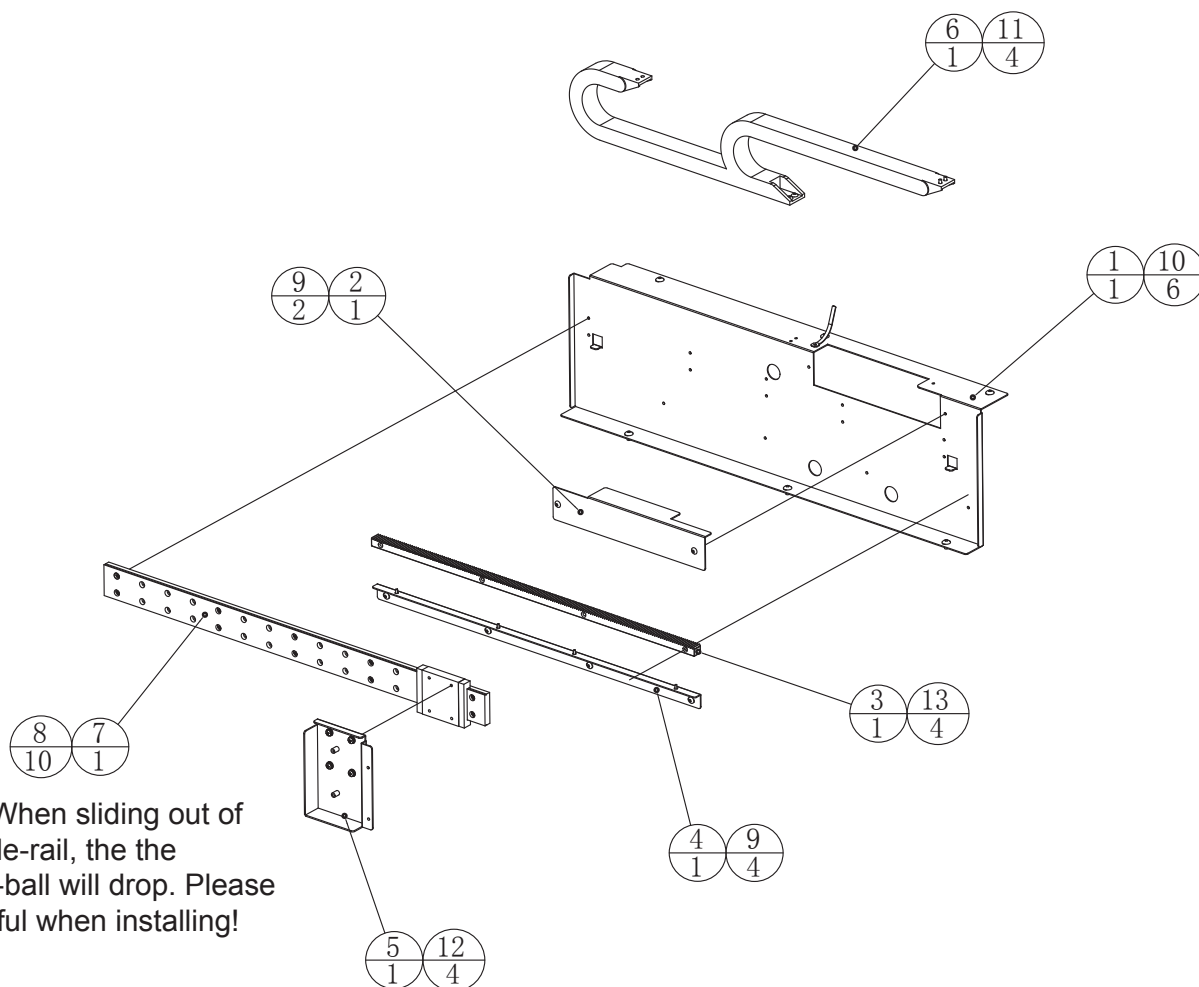

Note: When sliding out of the guide-rail, the the joystick-ball will drop. Please be careful when installing!

| | | | | | |
|----|-------------|---|-----------------------------|-----|--------------|
| 13 | | Cross flat-head screw | M3*6 (chrome plated) | 4 | 1.6.LS230022 |
| 12 | | Cross round-head screw | M4*6 (chrome plated) | 4 | 1.6.LS840012 |
| 11 | | Hexagon flat-head screw | M4*8 (chrome plated) | 4 | 1.6.LS140032 |
| 10 | | Hexagon flat-head screw | M5*8 (chrome plated) | 6 | 1.6.LS150012 |
| 9 | | Hexagon flat-head screw | M4*6 (chrome plated) | 6 | 1.6.LS140012 |
| 8 | | Cross round-head screw | M4*10 (chrome plated) | 10 | 1.6.LS741012 |
| 7 | | Linear guide | MGW 15H-600 | 1 | 1.4.DG010041 |
| 6 | | Drag chain | 18*18 – 510Long semi-closed | 1 | 1.8.AA000133 |
| 5 | PP-0501A05 | Horizontally-moving slide-frame | SPCC-1.5T | 1 | |
| 4 | PP-0501A04 | Horizontally-moving rack iron-pad | SPCC-1.2T | 1 | |
| 3 | PP-0501A03 | Horizontally-moving rack | nylon | 1 | |
| 2 | PP-0501A02 | Cover plate for control-panel service-hatch | SPCC-1.2T | 1 | |
| 1 | PP-0501A01 | Front horizontally-moving fixing-board | SPCC-1.2T | 1 | |
| SN | Drawing No. | Name | Materials/specifications | Qty | Note |

6.7.2 Horizontally-moving rear guide-rail components (PP-0502000)

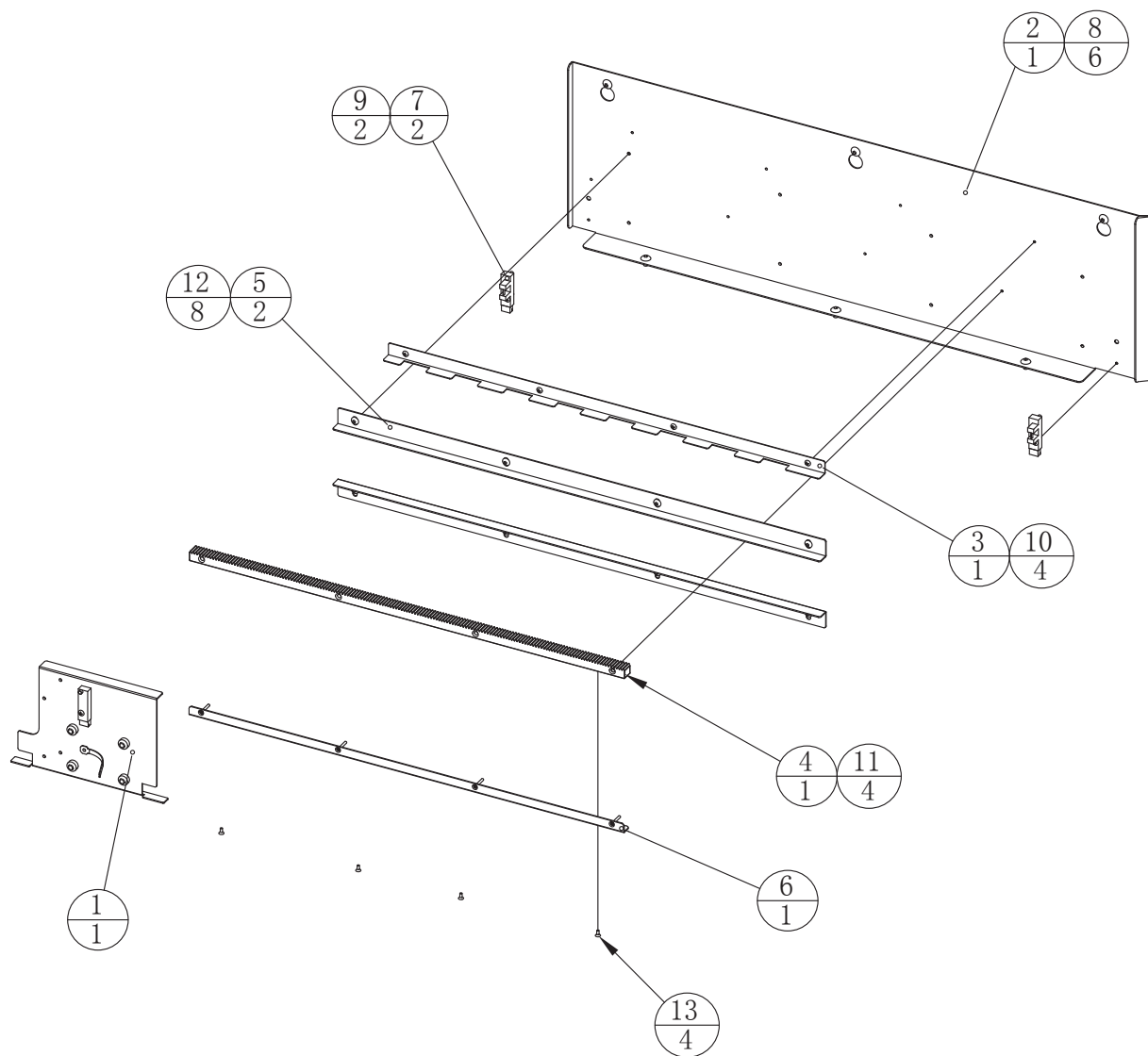

| | | | | | |
|----|--------------|---------------------------------------|--------------------------|-----|---------------|
| 13 | | Phillips countersunk screws | M3*6 (chrome plated) | 4 | 1.6.LSC30022 |
| 12 | | Hexagon flat-head screw | M4*6 (chrome plated) | 8 | 1.6.LS140012 |
| 11 | | Cross countersunk-head screw | M3*16 (chrome plated) | 4 | 1.6.LSC31031 |
| 10 | | Cross flat-head screw | M3*6 (chrome plated) | 4 | 1.6.LS230022 |
| 9 | | Cross flat-head screw | M3*12 (chrome plated) | 2 | 1.6.LS231022 |
| 8 | | Hexagon flat-head screw | M5*8 (chrome plated) | 6 | 1.6.LS150012 |
| 7 | | Sensor | KI1300-AA07LF | 2 | 5.4.WECHE0004 |
| 6 | PP-0502A05 | Rack flat iron | SPCC-1.2T | 1 | |
| 5 | PP-0502A04 | Horizontally-moving rollway iron | SPCC-1.2T | 2 | |
| 4 | PP-0501A03 | Horizontally-moving rack | nylon | 1 | |
| 3 | PP-0502A02 | Horizontally-moving optical-eye stop | SPCC-0.8T | 1 | |
| 2 | PP-0502A01 | Rear horizontally-moving fixed-plate | SPCC-1.2T | 1 | |
| 1 | PP-0502000-A | Horizontally-rolling plate components | | 1 | |
| SN | Drawing No. | Name | Materials/specifications | Qty | Note |

6.7.2.1 Horizontally-moving roller-plate components (PP-0502000-A)

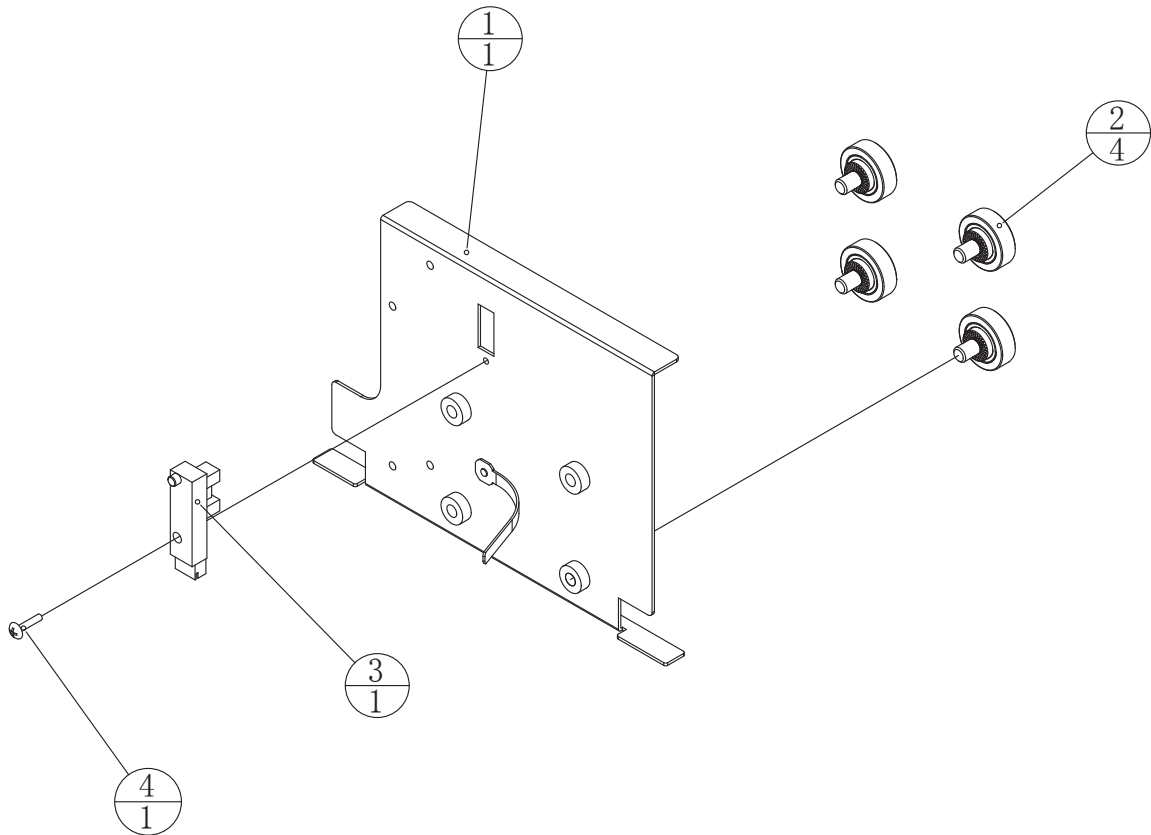

| | | | | | |
|----|-------------|------------------------------|--------------------------|-----|---------------|
| 4 | | Cross flat-head screw | M3*12 (chrome plated) | 1 | 1.6.LS231022 |
| 3 | | Sensor | KI1300-AA07LF | 1 | 5.4.WECHE0004 |
| 2 | | Resin bearing | DR22C2 | 4 | 1.4.ZC030017 |
| 1 | PP-0502A03 | Horizontally-moving backseat | SPCC-1.2T | 1 | |
| SN | Drawing No. | Name | Materials/specifications | Qty | Note |

6.7.3 Longitudinally-moving rail components (PP-0503000)

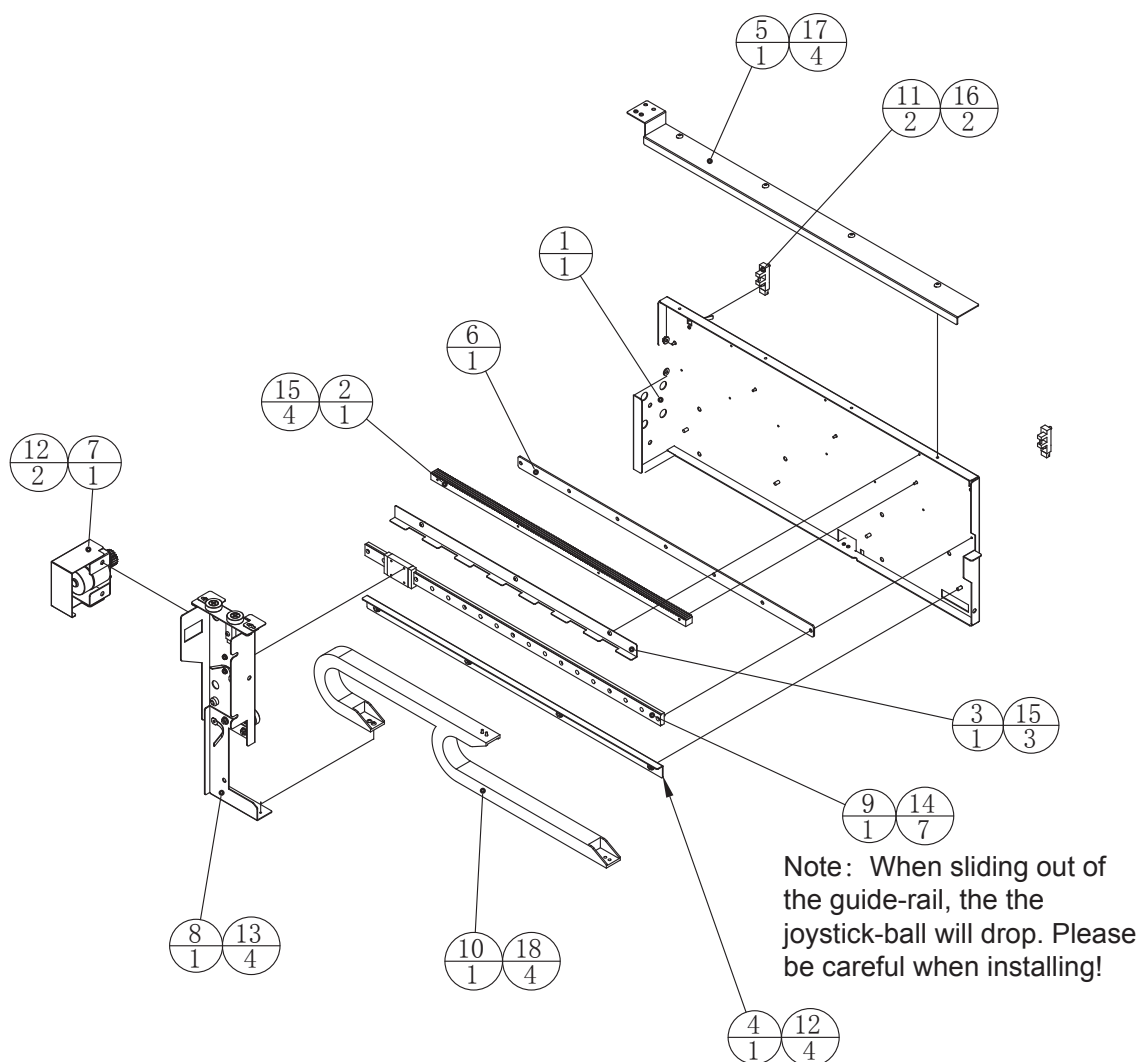

| | | | | | |
|----|--------------|--|------------------------------|-----|---------------|
| 18 | | Cross flat-head screw | M3*8 (chrome plated) | 4 | 1.6.LS230032 |
| 17 | | Hexagon flat-head screw | M4*6 (chrome plated) | 4 | 1.6.LS140012 |
| 16 | | Cross flat-head screw | M3*12 (chrome plated) | 2 | 1.6.LS231022 |
| 15 | | Cross flat-head screw | M3*6 (chrome plated) | 7 | 1.6.LS230022 |
| 14 | | Cross round-head screw | M3*8 (chrome plated) | 7 | 1.6.LS730032 |
| 13 | | Cross round-head combined screws | M3*6 (chrome plated) | 4 | 1.6.LS830012 |
| 12 | | Hexagon nut with flange | M4 (color coating) | 6 | 1.6.LM204013 |
| 11 | | Sensor | KI1300-AA07LF | 2 | 5.4.WECHE0004 |
| 10 | | Drag chain | 15*15 – 420 long bridge-type | 1 | 1.8.AA000132 |
| 9 | | Linear guide | MGW9H-550 | 1 | 1.4.DG010042 |
| 8 | PP-0503000-B | Longitudinally-moving frame components | | 1 | |
| 7 | PP-0503000-A | Longitudinal motor | | 1 | |
| 6 | PP-0503A09 | Longitudinal sliding-rail pad | SPCC-2.0T | 1 | |
| 5 | PP-0503A05 | Upper longitudinal wheel-track | SPCC-1.2T | 1 | |
| 4 | PP-0503A04 | Lower longitudinal wheel-track | SPCC-1.2T | 1 | |
| 3 | PP-0503A03 | Longitudinal optical-eye baffle | SPCC-0.8T | 1 | |
| 2 | PP-0503A02 | Longitudinal rack | nylon | 1 | |
| 1 | PP-0503A01 | Longitudinal-rail fixed-plate | SPCC-1.2T | 1 | |
| SN | Drawing No. | Name | Materials/specifications | Qty | Note |

6.7.3.1 Longitudinally-moving motor components (PP-0503000-A)

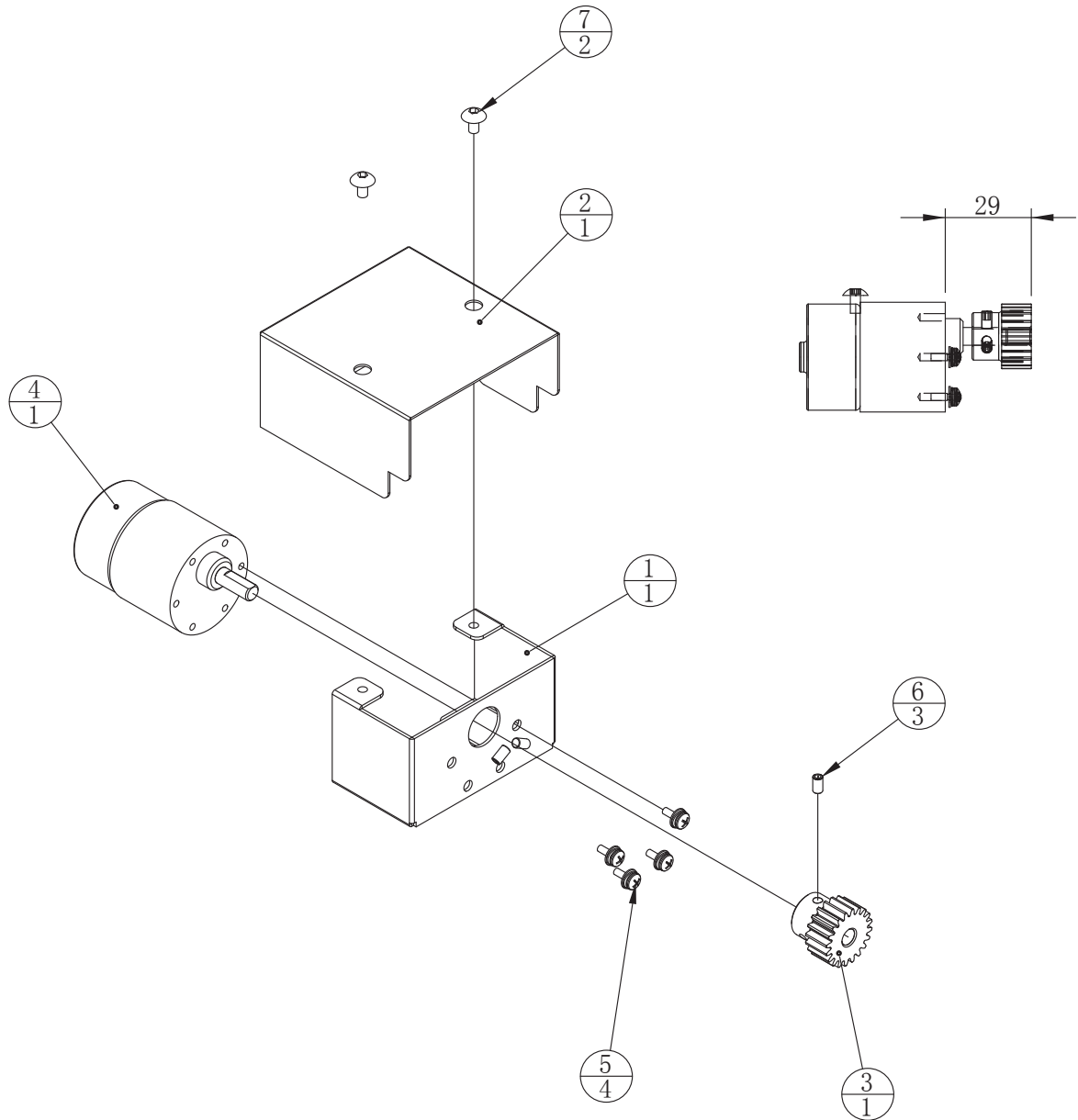

Note: Coating with screw glue

| | | | | | |
|----|-------------|---|--------------------------|-----|---------------|
| 7 | | Hexagon flat-head screw | M4*6 (chrome plated) | 2 | 1.6.LS140012 |
| 6 | | Headless socket screw | M4*6 (black coating) | 3 | 1.6.LST40011# |
| 5 | | Cross round-head combined screw | M3*6 (chrome plated) | 4 | 1.6.LS830012 |
| 4 | | Motor | TG-301DA-SR-65-CHA,24V | 1 | 1.4.MD100031 |
| 3 | PP-0503A13 | Horizontally-moving motor-gear | nylon | 1 | |
| 2 | PP-0503A10 | Longitudinally-moving motor cover-plate | SPCC-0.8T | 1 | |
| 1 | PP-0503A08 | Longitudinally-moving motor fixed-iron | SPCC-1.2T | 1 | |
| SN | Drawing No. | Name | Materials/specifications | Qty | Note |

6.7.3.2 Longitudinally-moving frame components (PP-0503000-B)

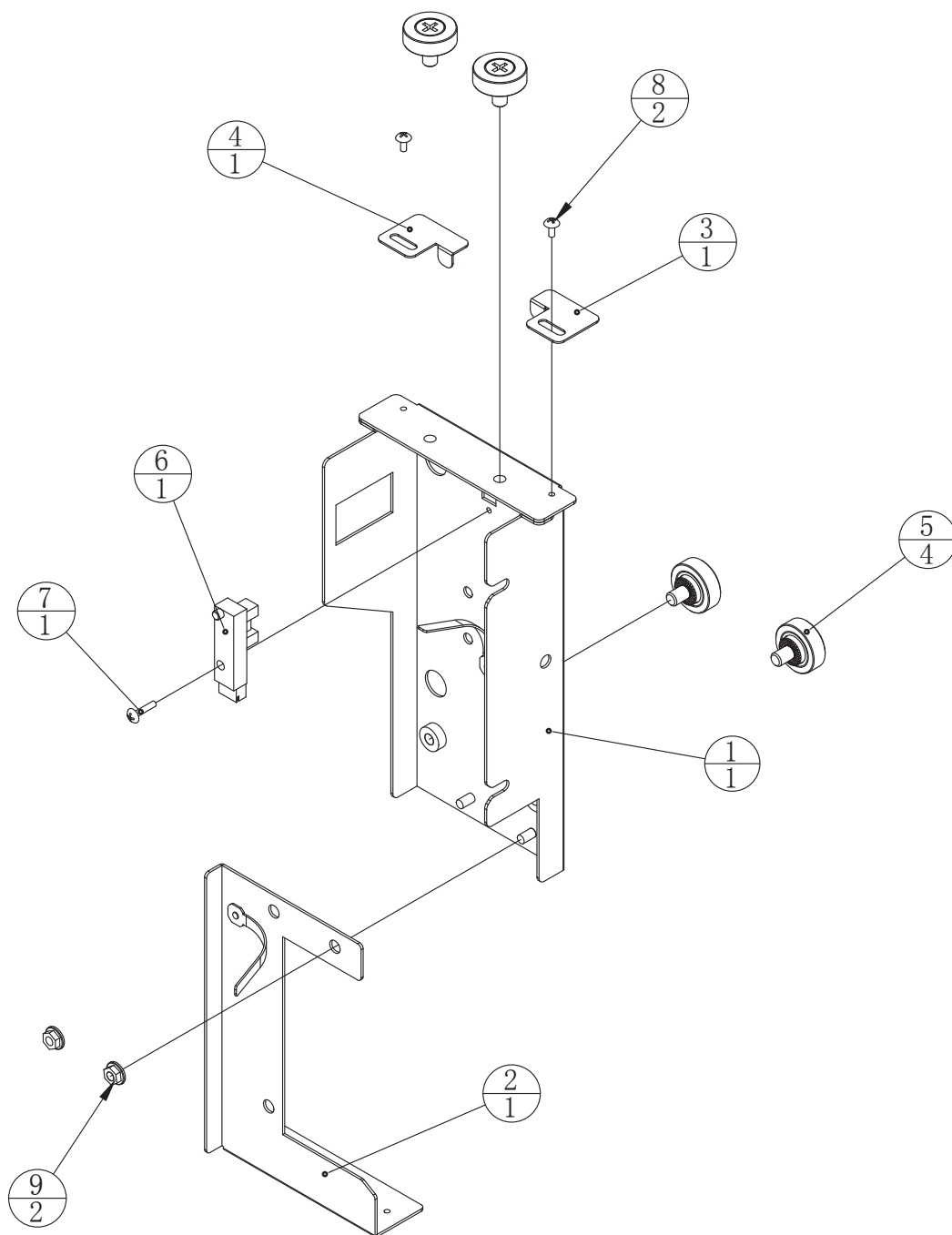

| | | | | | |
|----|-------------|---|--------------------------|-----|---------------|
| 9 | | Hexagon nut with flange | M4 (color coating) | 2 | 1.6.LM204013 |
| 8 | | Cross flat-head screw | M3*6 (chrome plated) | 2 | 1.6.LS230022 |
| 7 | | Cross flat-head screw | M3*12 (chrome plated) | 1 | 1.6.LS231022 |
| 6 | | Sensor | KI1300-AA07LF | 1 | 5.4.WECHE0004 |
| 5 | | Resin bearing | DR22C2 | 4 | 1.4.ZC030017 |
| 4 | PP-0503A12 | Left longitudinally-moving optical-eye baffle | SPCC-0.8T | 1 | |
| 3 | PP-0503A11 | Longitudinally-moving optical-eye baffle | SPCC-0.8T | 1 | |
| 2 | PP-0503A07 | Longitudinal drag-chain fixed-iron | SPCC-1.2T | 1 | |
| 1 | PP-0503A06 | Longitudinal slider fixed-iron | SPCC-1.2T | 1 | |
| SN | Drawing No. | Name | Materials/specifications | Qty | Note |

6.7.4 Horizontally-moving motor components (PP-0504000)

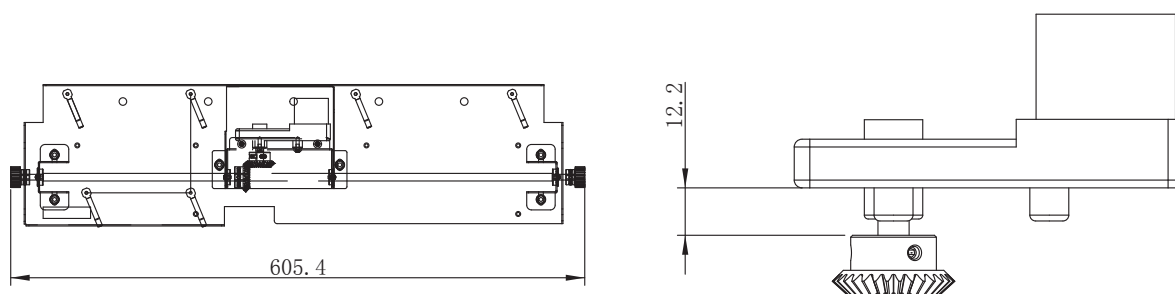
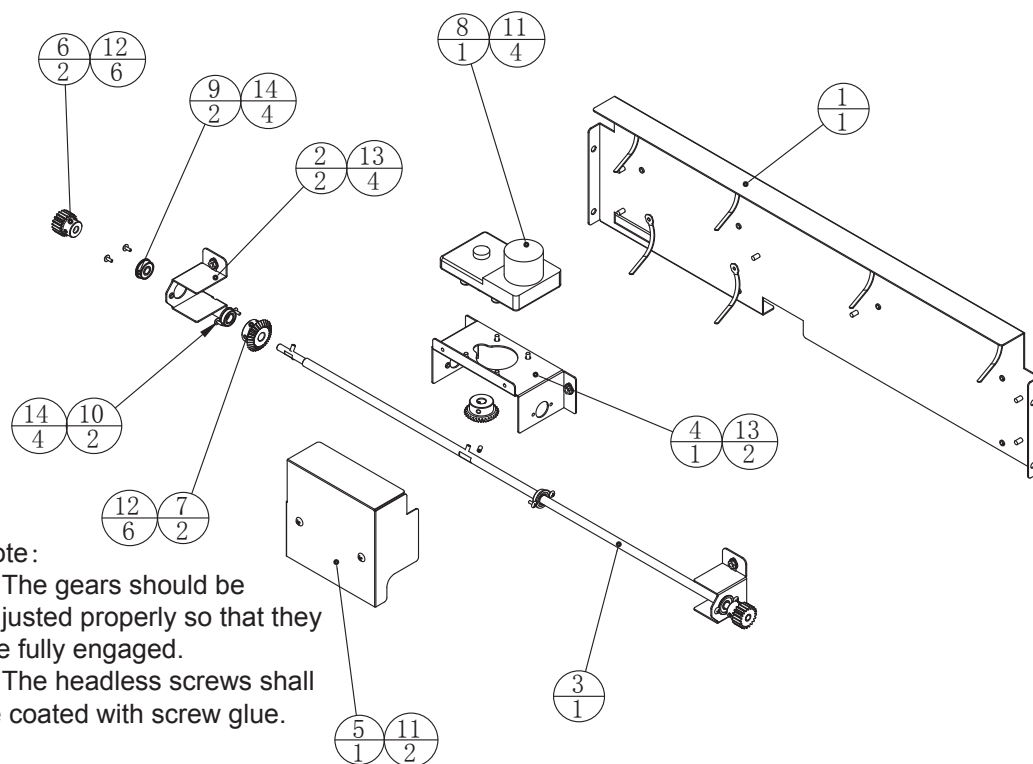

| | | | | | |
|----|-------------|---|--------------------------|-----|---------------|
| 14 | | Cross flat-head screw | M3*6 (chrome plated) | 8 | 1.6.LS230022 |
| 13 | | Hexagon nut with flange | M4 (color coating) | 6 | 1.6.LM204013 |
| 12 | | Headless socket screw | M4*6 (black coating) | 12 | 1.6.LST40011# |
| 11 | | Cross flat-head screw | M4*6 (chrome plated) | 6 | 1.6.LS240012 |
| 10 | | Flange bearing | LF-1680HH | 2 | 1.4.ZC000065 |
| 9 | | Flange bearing | F606-H-ZZ | 2 | 1.4.ZC000064 |
| 8 | | Motor | TG-05K-BG-60-CKA, 24V | 1 | 1.4.MD100032 |
| 7 | KC-0704A02 | Bevel gear | Q235 | 2 | |
| 6 | PP-0503A13 | Horizontally-moving motor-gear | nylon | 2 | |
| 5 | PP-0504A05 | Horizontally-moving motor cover-plate | SPCC-0.8T | 1 | |
| 4 | PP-0504A04 | Horizontally-moving motor fixed-iron | SPCC-1.2T | 1 | |
| 3 | PP-0504A03 | Horizontally-moving shaft | 45 | 1 | |
| 2 | PP-0504A02 | Horizontally-moving shaft supporting-iron | SPCC-1.2T | 2 | |
| 1 | PP-0504A01 | Horizontally-moving motor beam | SPCC-1.2T | 1 | |
| SN | Drawing No. | Name | Materials/specifications | Qty | Note |

6.7.5 Total jacking-rod components (PP-0505000)

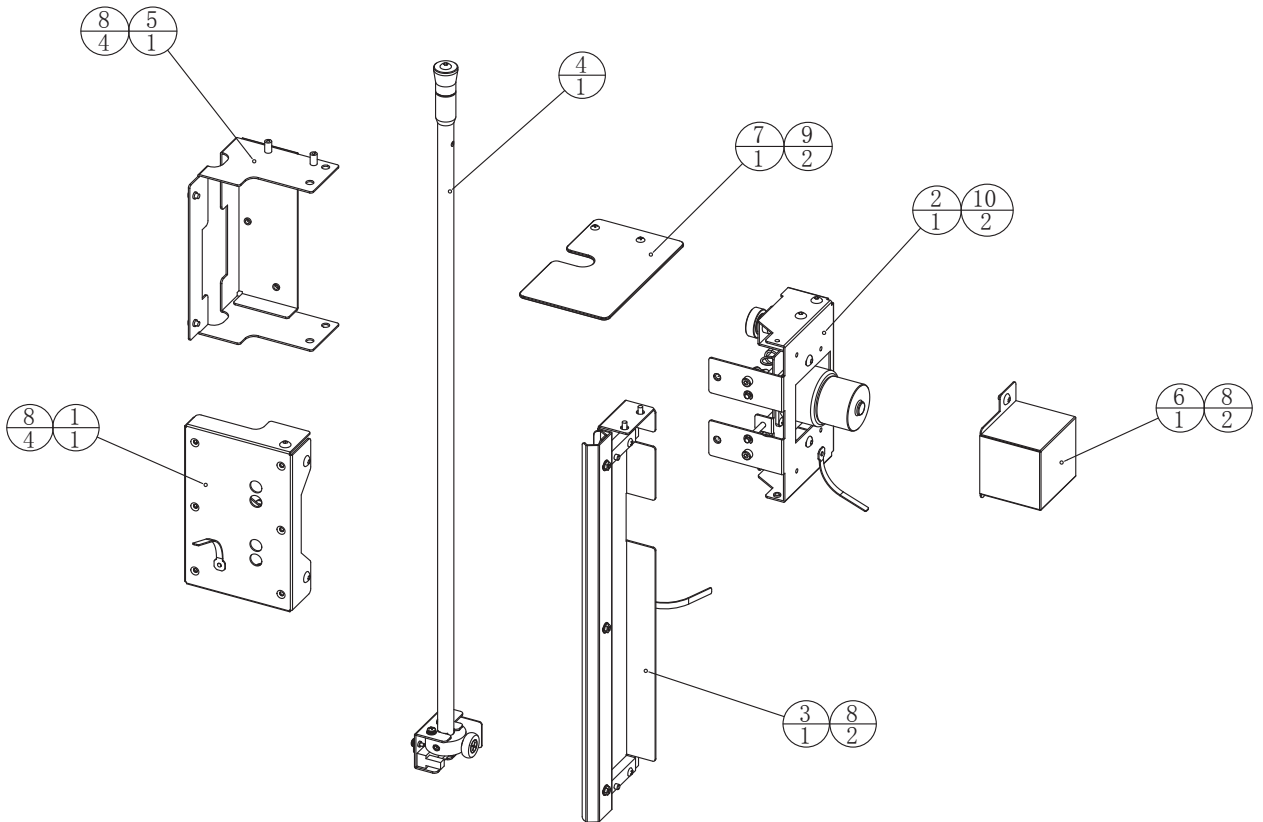

| | | | | | |
|----|--------------|----------------------------------|--------------------------|-----|--------------|
| 10 | | Hexagon nut with flange | M4 (color coating) | 2 | 1.6.LM204013 |
| 9 | | Cross flat-head screw | M3*6 (chrome plated) | 2 | 1.6.LS230022 |
| 8 | | Hexagon flat-head screw | M4*6 (chrome plated) | 12 | 1.6.LS140012 |
| 7 | PP-0503D01 | Acryl on push-rod mirror-surface | Mirror-surface PMMA-2.0T | 1 | |
| 6 | PP-0505A22 | Jacking-motor cover-plate | SPCC-0.8T | 1 | |
| 5 | PP-0505A21 | Jacking-box cover-plate | SPCC-1.2T | 1 | |
| 4 | PP-0505000-D | Push-rod components | | 1 | |
| 3 | PP-0505000-C | Push-rod sensor components | | 1 | |
| 2 | PP-0505000-B | Push-rod motor components | | 1 | |
| 1 | PP-0505000-A | Push-rod fixed-wheel components | | 1 | |
| SN | Drawing No. | Name | Materials/specifications | Qty | Note |

6.7.5.1 Jacking-rod fixing-wheel components (PP-0505000-A)

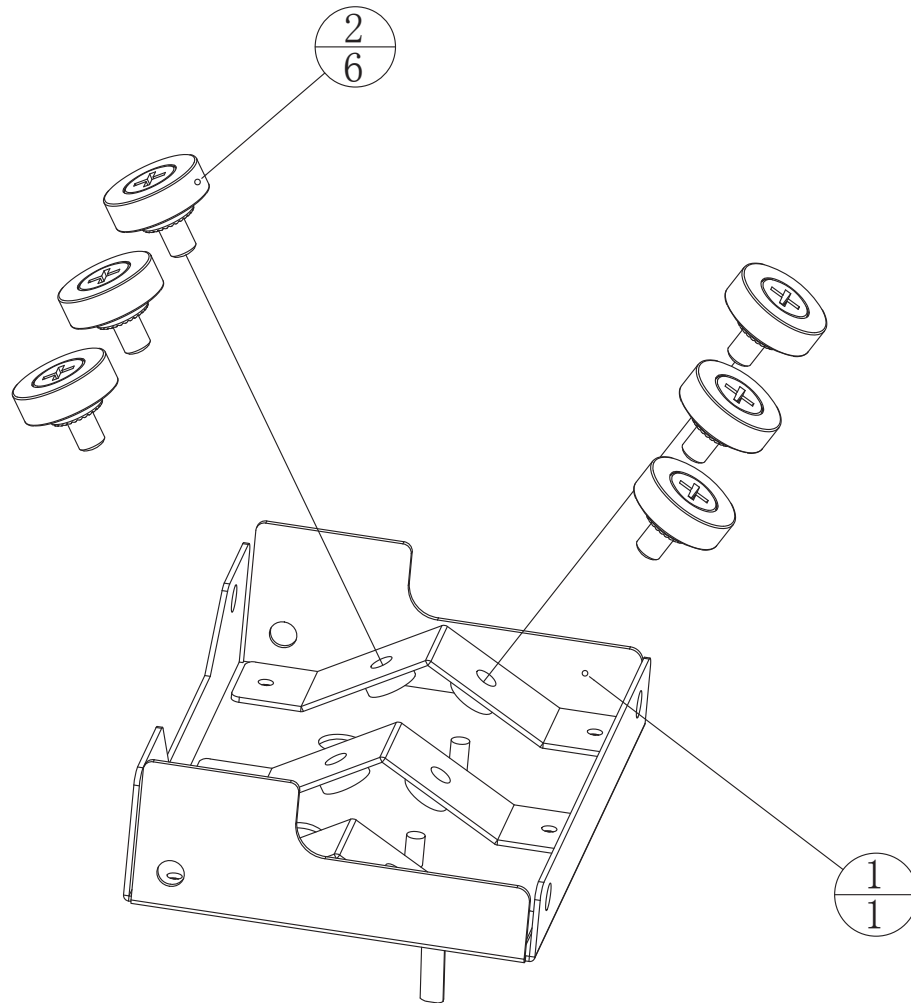

| | | | | | |
|----|-------------|------------------|--------------------------|-----|--------------|
| 2 | | Resin bearing | DR22C2 | 6 | 1.4.ZC030017 |
| 1 | PP-0505A01 | Roller-seat iron | | 1 | |
| SN | Drawing No. | Name | Materials/specifications | Qty | Note |

6.7.5.2 Jacking-rod motor components (PP-0505000-B)

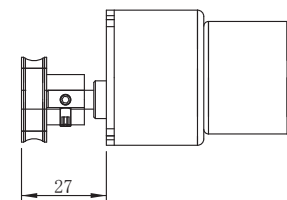
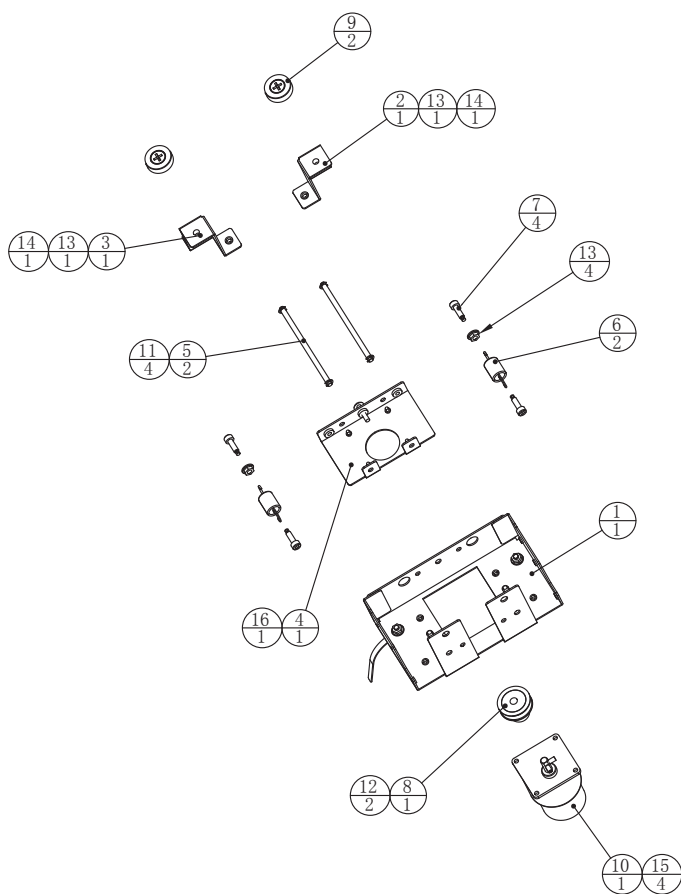

Note:

1. Adjust the roller position properly so that it can press on the jacking-rod center.
2. Coating with screw glue!

| | | | | | |
|----|-------------|--------------------------|--------------------------|-----|---------------|
| 16 | | Cross flat-head screw | M4*16 (chrome plated) | 1 | 1.6.LS241032 |
| 15 | | Cross flat-head screw | M3*8 (chrome plated) | 4 | 1.6.LS230032 |
| 14 | | Hexagon flat-head screw | M4*6 (chrome plated) | 2 | 1.6.LS140012 |
| 13 | | Hexagon nut with flange | M4 (color coating) | 4 | 1.6.LM204013 |
| 12 | | Headless socket screw | M4*6 (black coating) | 2 | 1.6.LST40011# |
| 11 | | Split washer (e-buckle) | M3(black coating) | 4 | 1.6.DQ103011 |
| 10 | | Motor | TG-05L-AMD-150-CKA, 24V | 1 | 1.4.MD100028 |
| 9 | | Resin bearing | DR22C2 | 2 | 1.4.ZC030017 |
| 8 | PP-0505C01 | Polyurethane roller | | 1 | |
| 7 | PP-0505A24 | Spring adjusting-screw | SUS304 | 4 | |
| 6 | PP-0505A23 | Roller spring | SUS304-WPB | 2 | |
| 5 | PP-0505A06 | Roller sliding shaft | 45 | 2 | |
| 4 | PP-0505A05 | Jacking-motor fixed-iron | SPCC-1.2T | 1 | |
| 3 | PP-0505A04 | Lower roller-iron | SPCC-1.2T | 1 | |
| 2 | PP-0505A03 | Upper roller-iron | SPCC-1.2T | 1 | |
| 1 | PP-0505A02 | Roller fixing-plate | SPCC-1.2T | 1 | |
| SN | Drawing No. | Name | Materials/specifications | Qty | Note |

6.7.5.3 Jacking-rod sensor components (PP-0505000-C)

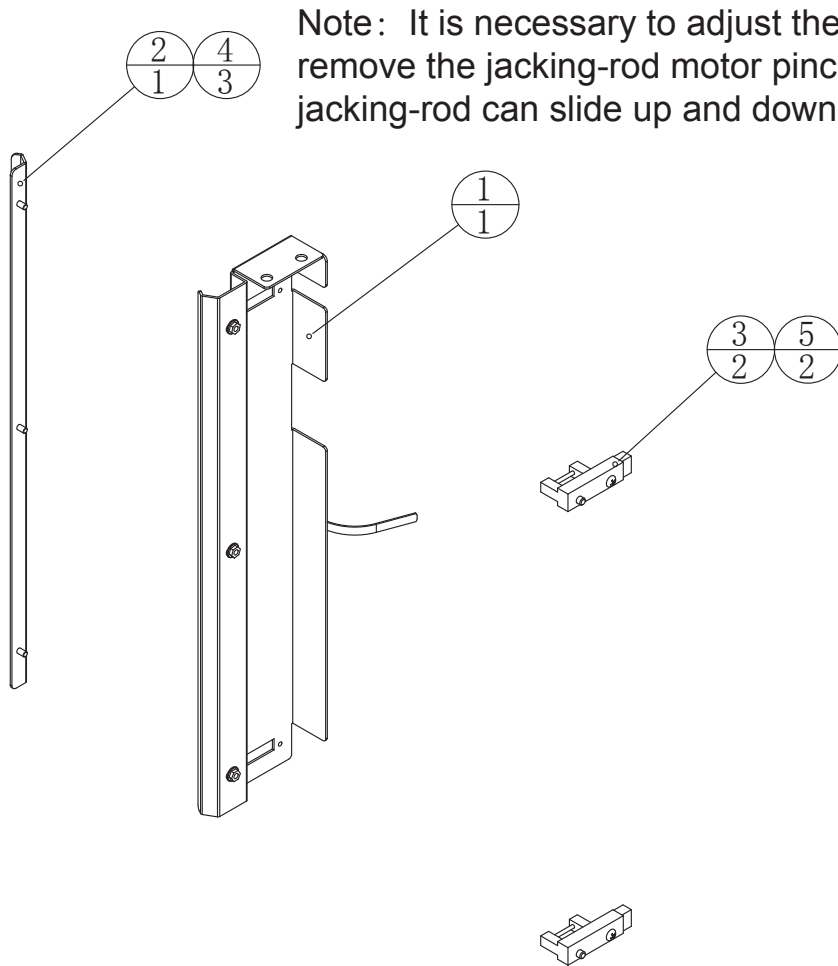

| | | | | | |
|----|-------------|-------------------------|--------------------------|-----|--------------|
| 5 | | Cross flat-head screw | M3*12 (chrome plated) | 2 | 1.6.LS231022 |
| 4 | | Hexagon nut with flange | M3 (color coating) | 3 | 1.6.LM203013 |
| 3 | | Sensor | KI1249-AALF | 2 | 1.4.GY100050 |
| 2 | PP-0505A25 | Roller channel-iron | SPCC-1.2T | 1 | |
| 1 | PP-0505A20 | Lifting raceway-iron | SPCC-1.2T | 1 | |
| SN | Drawing No. | Name | Materials/specifications | Qty | Note |

6.7.5.4 Jacking-rod components (PP-0505000-D)

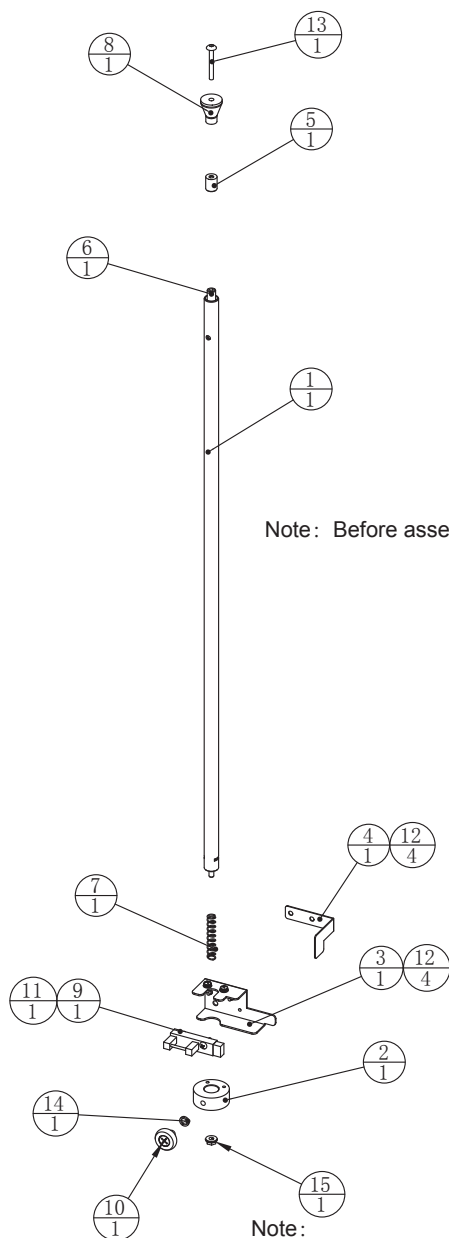

Note: Before assembling, the tube outside should be cleaned, without oil.

Note:
1. Applying with screw glue

| | | | | | |
|----|-------------|----------------------------------|--------------------------|-----|--------------|
| 15 | | Hexagon nut with flange | M4 (color coating) | 1 | 1.6.LM204013 |
| 14 | | Spring washer | M6 (chrome plated) | 1 | 1.6.DP206012 |
| 13 | | Hexagon flat-head screw | M4*30 (chrome plated) | 1 | 1.6.LS143012 |
| 12 | | Cross round-head combined screw | M3*6 (chrome plated) | 4 | 1.6.LS830012 |
| 11 | | Cross flat-head screw | M3*12 (chrome plated) | 1 | 1.6.LS231022 |
| 10 | | Outer arc plastic-wheel | DO-19-B0.5 | 1 | 1.4.HL010011 |
| 9 | | Sensor | KI1249-AALF | 1 | 1.4.GY100050 |
| 8 | PP-0505A16 | Small head | 5052-O | 1 | |
| 7 | PP-0505A13 | Push-rod compression-spring | SUS304-WPB | 1 | |
| 6 | PP-0505A12 | Push-rod core | SUS304 | 1 | |
| 5 | PP-0505A11 | Head bushing 02 | 5052-O | 1 | |
| 4 | PP-0505A10 | Lifting optical-eye baffle | SPCC-0.8T | 1 | |
| 3 | PP-0505A09 | Lifting electric eye fixing-iron | SPCC-1.2T | 1 | |
| 2 | PP-0505A08 | Iron-pipe retaining-ring | 5052-O | 1 | |
| 1 | PP-0505A07 | Outer lifting steel-pipe | SUS304 | 1 | |
| SN | Drawing No. | Name | Materials/specifications | Qty | Note |

6.8 Ramp net components (PP-0700000)

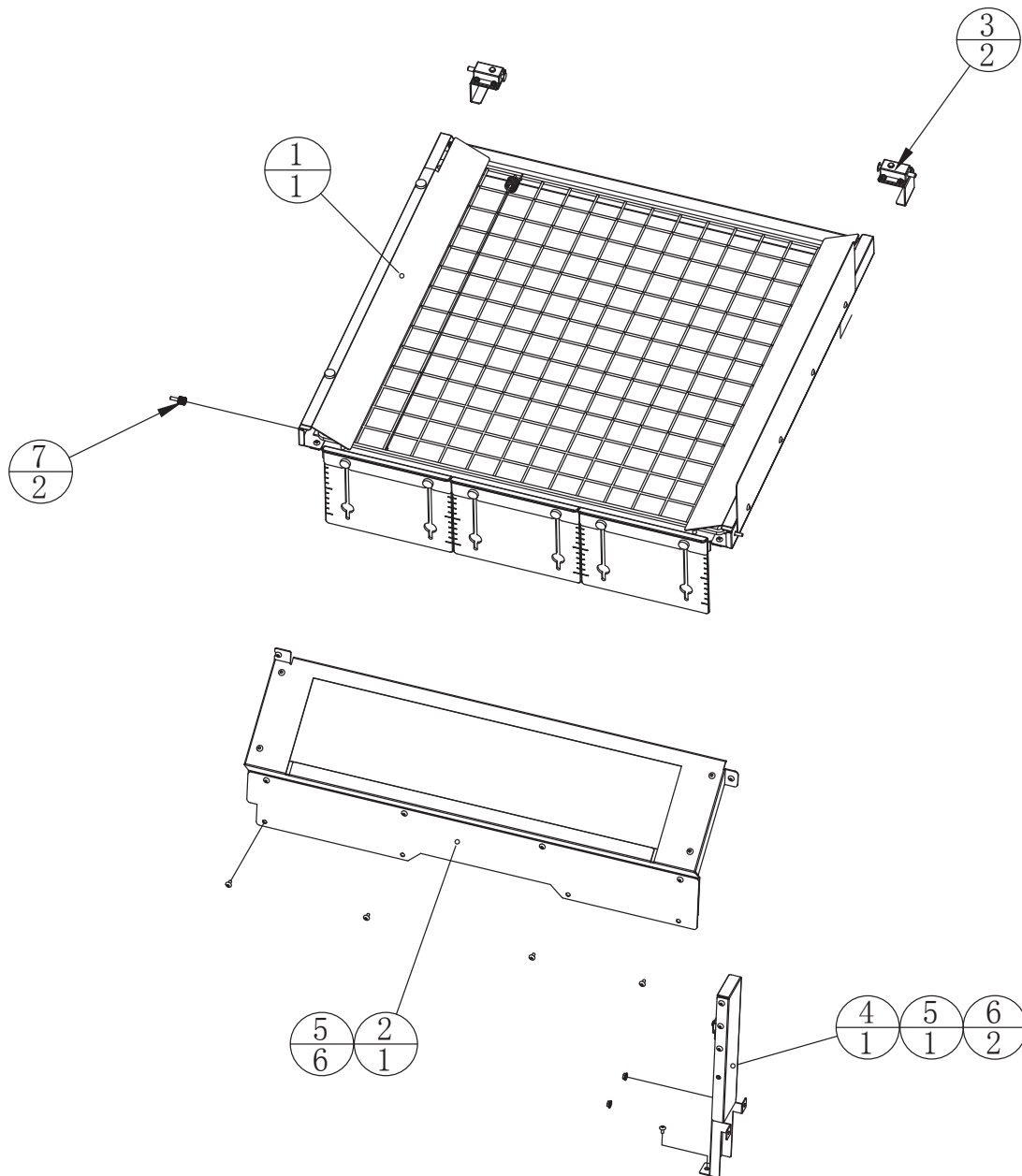

| | | | | | |
|----|-------------|--------------------------------|--------------------------|-----|--------------|
| 7 | | Rubber-head cross-groove screw | M4 * 12 (white) | 2 | |
| 6 | | Hexagon nut with flange | M4 (chrome plated) | 2 | 1.6.LM204013 |
| 5 | | Hexagon flat-head screw | M4*8 (chrome plated) | 7 | 1.6.LS140032 |
| 4 | PP-0704000 | Net front-pillar components | | 1 | |
| 3 | PP-0703000 | Net movable-pin components | | 2 | |
| 2 | PP-0702000 | Prize ramp-board components | | 1 | |
| 1 | PP-0701000 | Net components | | 1 | |
| SN | Drawing No. | Name | Materials/specifications | Qty | Note |

6.8.1 Net components (PP-0701000)

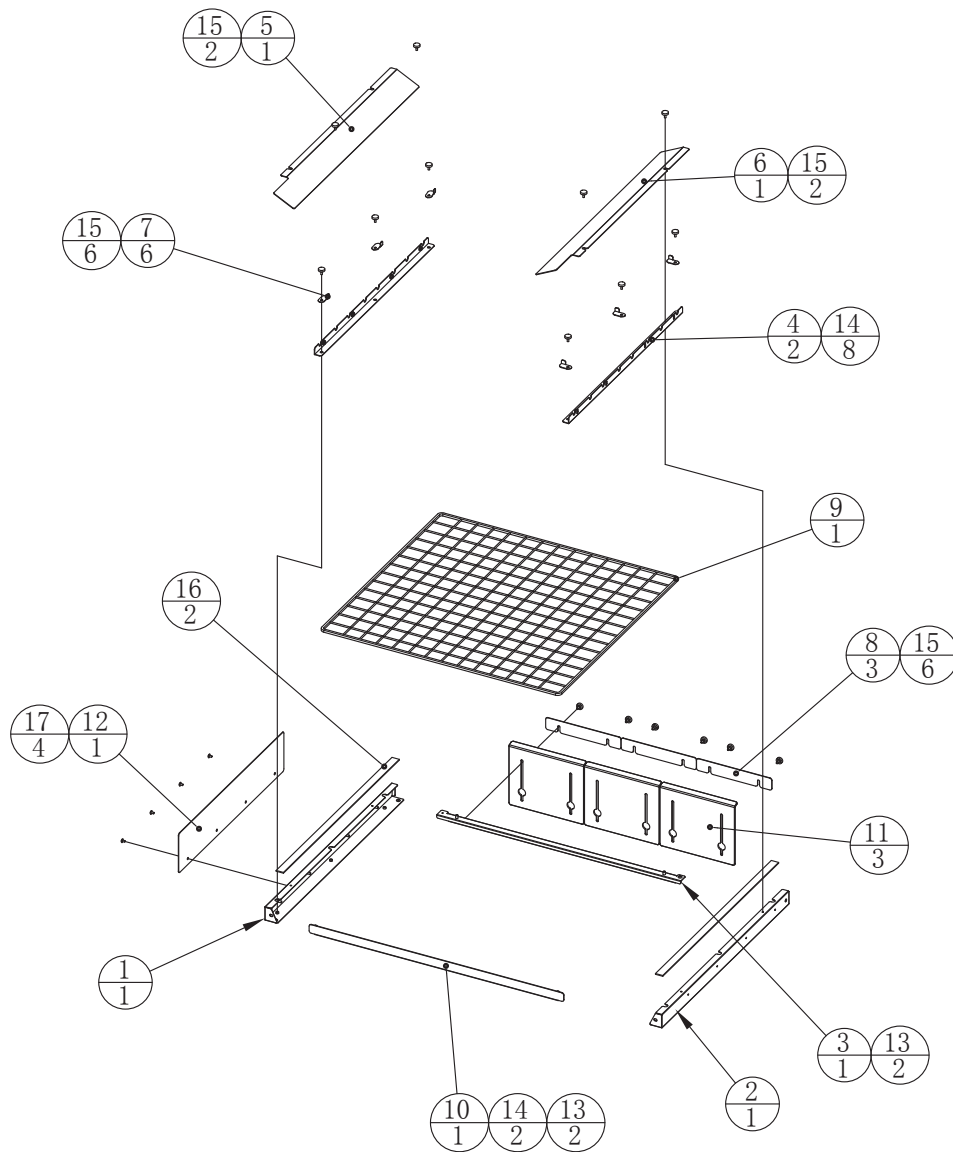

| | | | | | |
|----|-------------|-----------------------------------|--------------------------|-----|--------------|
| 17 | | Hexagon flat-head screw | M4*6 (chrome plated) | 4 | 1.6.LS140012 |
| 16 | | EVA sponge (single-side adhesive) | 2*18mm 10M/roll | 2 | 1.9.HM020020 |
| 15 | | Plastic-head screw | M4*8 (white) | 16 | 1.6.LSU40800 |
| 14 | | Hexagon nut with flange | M4 (color coating) | 10 | 1.6.LM204013 |
| 13 | | Cross flat-head screw | M4*6 (chrome plated) | 4 | 1.6.LS240012 |
| 12 | PP-0701D03 | Front prize baffle | PVC-1.0T | 1 | |
| 11 | PP-0701D01 | Prize baffle - long | PC-3.0T | 3 | |
| 10 | PP-0701A11 | Right net beam-iron | SPCC-1.5T | 1 | |
| 9 | PP-0701A09 | Prize baffle - small | | 1 | |
| 8 | PP-0701A08 | Baffle layering | SPCC-1.2T | 3 | |
| 7 | PP-0701A07 | net tablet | SPCC-1.2T | 6 | |
| 6 | PP-0701A06 | Inside net cover-plate | SPCC-1.2T | 1 | |
| 5 | PP-0701A05 | Outside net cover-plate | SPCC-1.2T | 1 | |
| 4 | PP-0701A04 | Lower net layering | SPCC-1.0T | 2 | |
| 3 | PP-0701A03 | Left/right net borders | SPCC-1.2T | 1 | |
| 2 | PP-0701A02 | Lower net back-frame | SPCC-1.0T | 1 | |
| 1 | PP-0701A01 | Lower net front-frame | SPCC-1.0T | 1 | |
| SN | Drawing No. | Name | Materials/specifications | Qty | Note |

6.8.2 Prize ramp-panel components (PP-0702000)

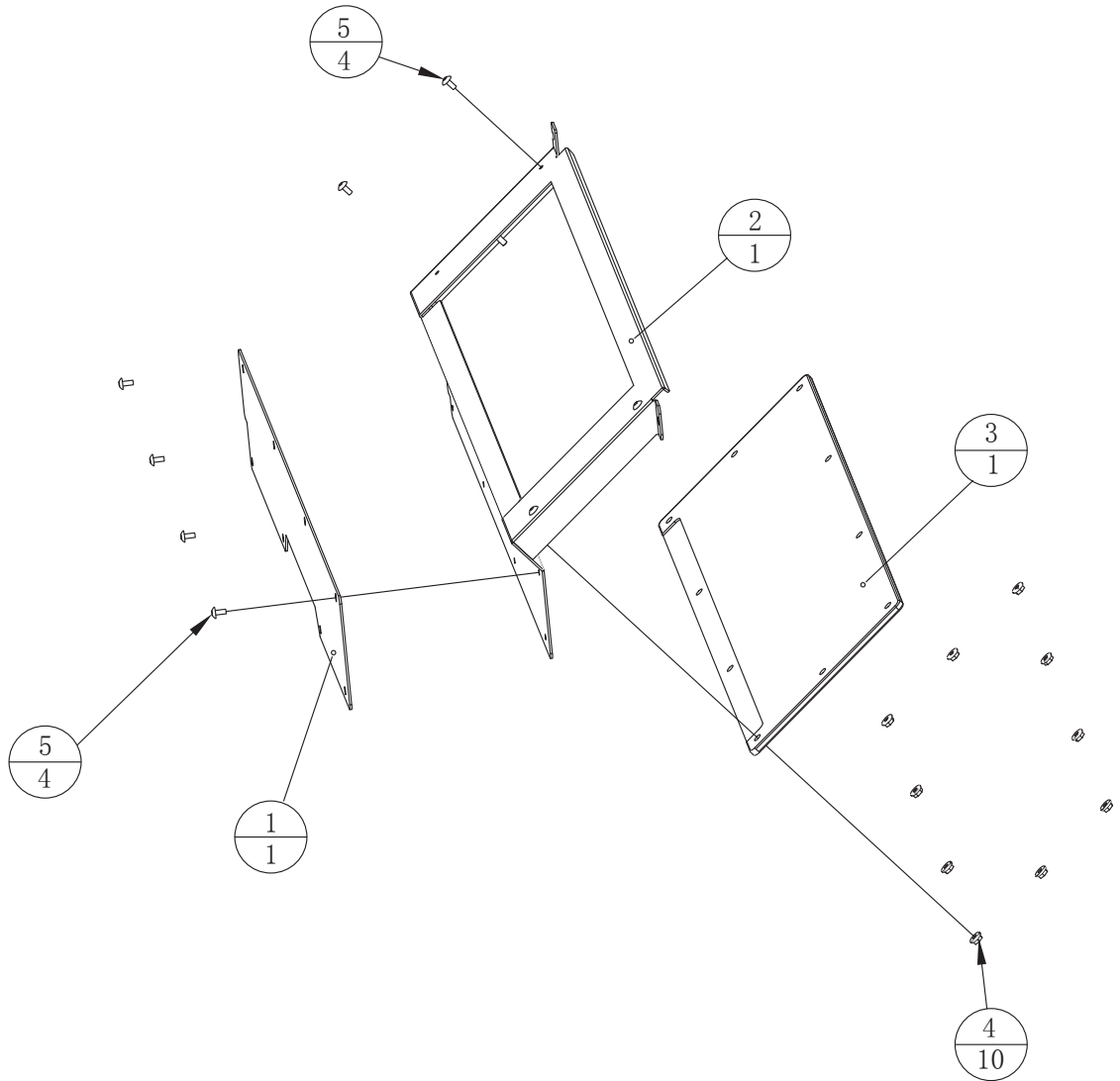

| | | | | | |
|----|-------------|---------------------------|--------------------------|-----|--------------|
| 5 | | Hexagon flat-head screw | M4*8 (chrome plated) | 8 | 1.6.LS140032 |
| 4 | | Hexagon nut with flange | M4 (color coating) | 10 | 1.6.LM204013 |
| 3 | PP-0702D01 | Inclined plate | PMMA-5.0T | 1 | |
| 2 | PP-0702A02 | Inclined plate fixed-iron | SPCC-1.5T | 1 | |
| 1 | PP-0702A01 | Inclined plate fixed-iron | SPCC-1.5T | 1 | |
| SN | Drawing No. | Name | Materials/specifications | Qty | Note |

6.8.3 Net movable-pin components (PP-0703000)

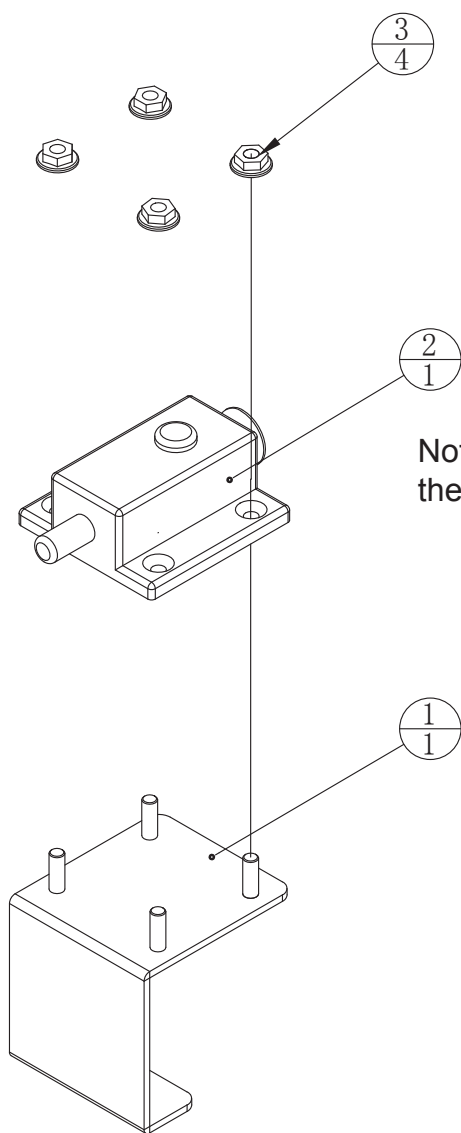

Note: If the hole can not be passed through, the hole can be suitably expanded

| | | | | | |
|----|-------------|--------------------------|--------------------------|-----|--------------|
| 3 | | Hexagon nut with flange | M3 (color coating) | 4 | 1.6.LM203013 |
| 2 | | Spring cotter | White cover-bolt | 1 | 1.4.TH020040 |
| 1 | PP-0703A01 | netscreen-pin fixed-iron | SPCC-1.5T | 1 | |
| SN | Drawing No. | Name | Materials/specifications | Qty | Note |

6.8.4 Net front-pillar components (PP-0704000)

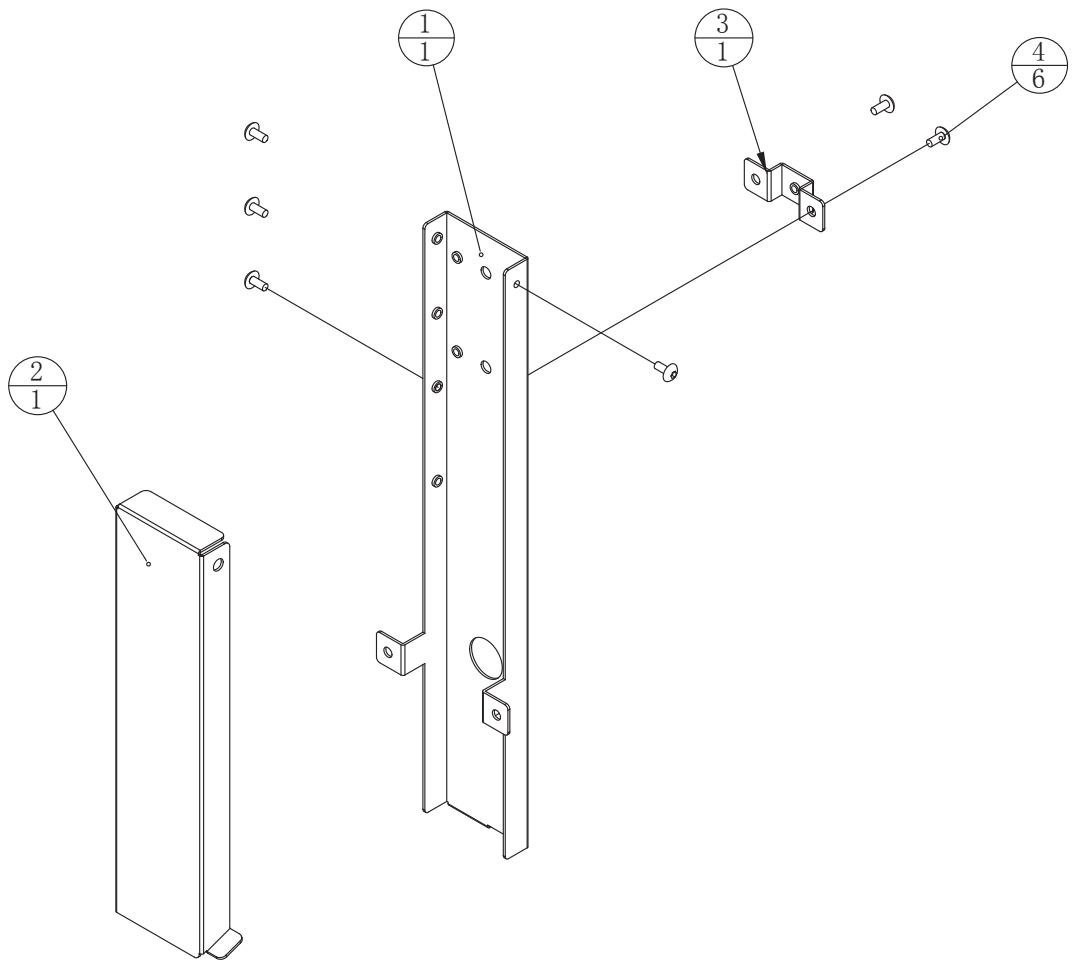

| | | | | | |
|----|-------------|-------------------------|--------------------------|-----|--------------|
| 4 | | Hexagon flat-head screw | M4*8 (chrome plated) | 6 | 1.6.LS140032 |
| 3 | PP-0704A03 | net pin-seat | | 1 | |
| 2 | PP-0704A02 | No.2 net pillar-iron | SPCC-1.2T | 1 | |
| 1 | PP-0704A01 | No.1 net pillar-iron | SPCC-1.2T | 1 | |
| SN | Drawing No. | Name | Materials/specifications | Qty | Note |

6.9 Prize-lane cover-plate components (PP-0800000)

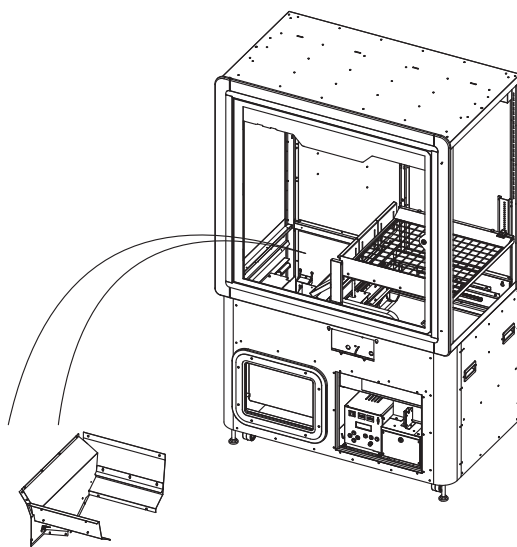
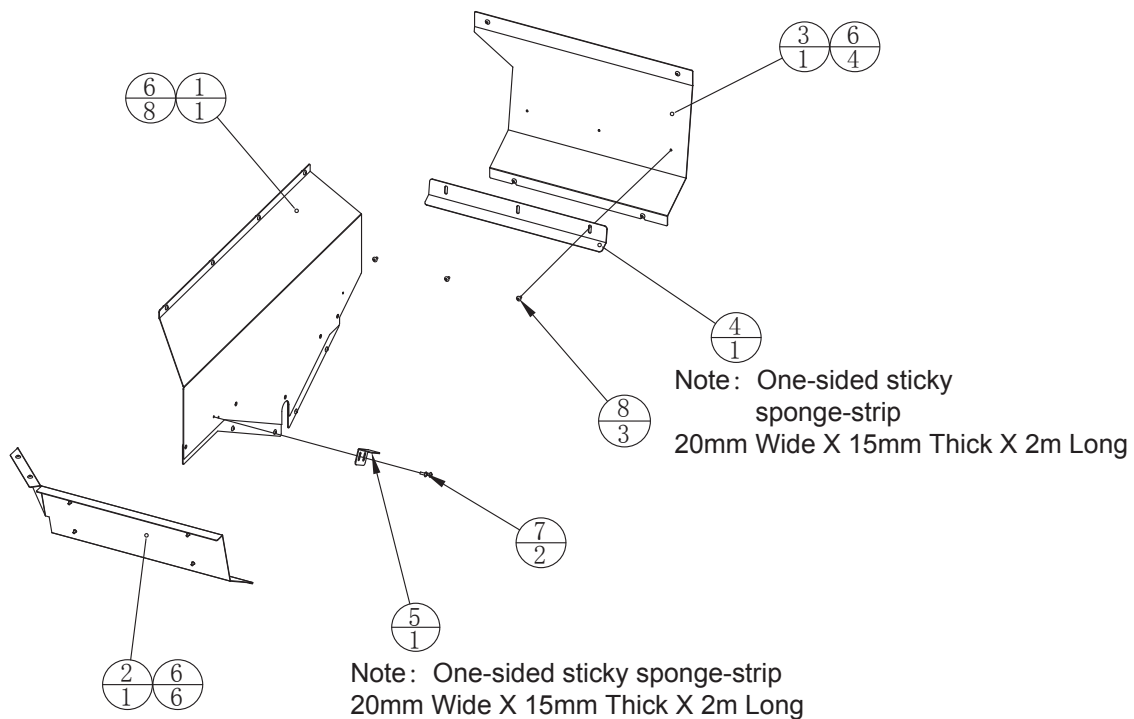

Schematic diagram for installing the components onto the game

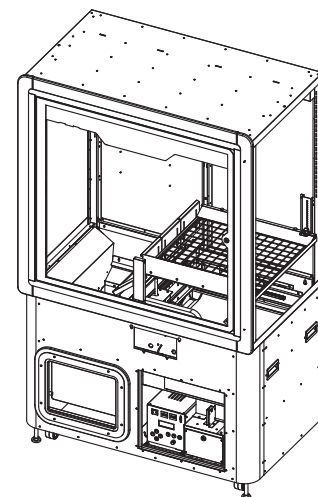

Effect after installation

| | | | | | |
|----|-------------|--------------------------------|--------------------------|-----|--------------|
| 8 | | Hexagon flat-head screw | M4*8 (black coating) | 3 | 1.6.LS140021 |
| 7 | | Cross flat-head screw | M4*10 (chrome plated) | 2 | 1.6.LS241012 |
| 6 | | Hexagon flat-head screw | M4*6 (chrome plated) | 18 | 1.6.LS140012 |
| 5 | PP-0101A08 | Short sealing-plate limit-iron | SPCC-1.2T | 1 | |
| 4 | PP-0800A04 | Long sealing-plate limit-iron | SPCC-1.2T | 1 | |
| 3 | PP-0800A03 | Rear prize-lane cover-plate | SPCC-1.2T | 1 | |
| 2 | PP-0800A02 | Front prize-lane cover-plate | SPCC-1.2T | 1 | |
| 1 | PP-0800A01 | Left prize-lane sealing-plate | | 1 | |
| SN | Drawing No. | Name | Materials/specifications | Qty | Note |

6.10 Prize display-board components (PP-0900000)

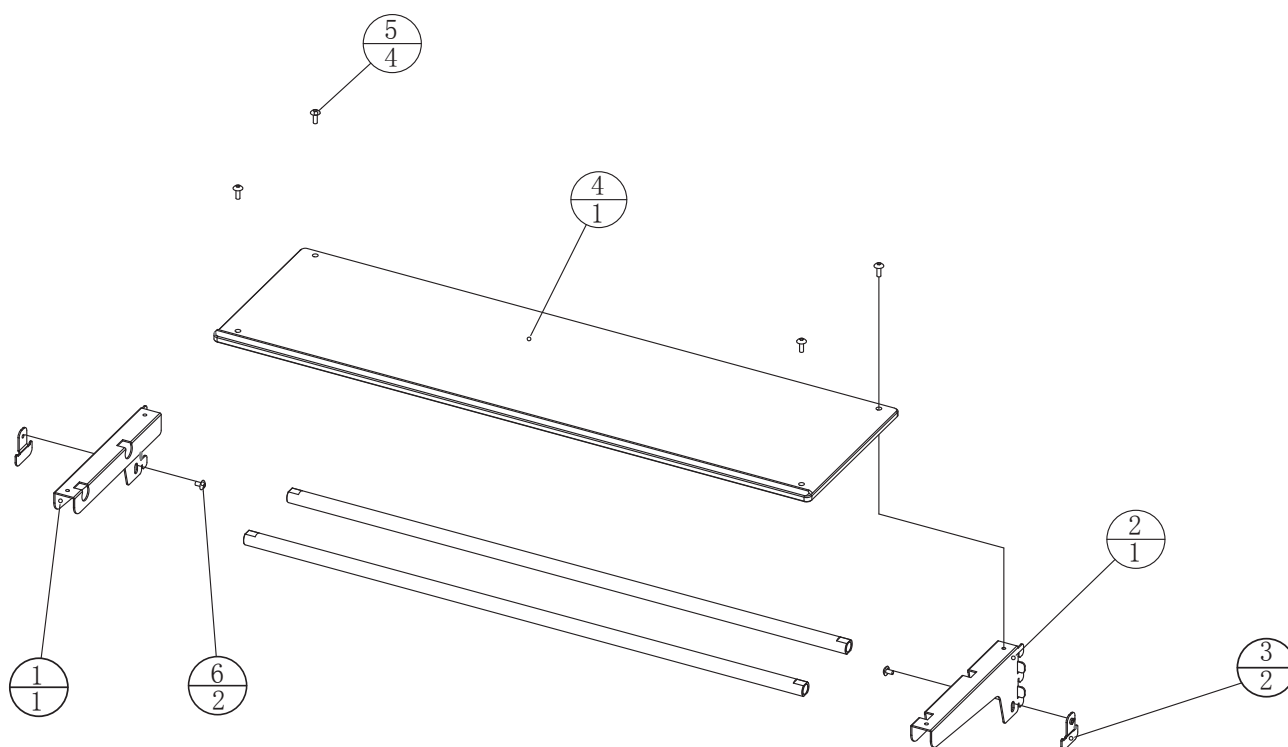

| | | | | | |
|----|-------------|--|--------------------------|-----|--------------|
| 7 | PP-0900A04 | Prize-rack tube | 6061 | 2 | |
| 6 | | Hexagon flat-head screw | M4*6 (chrome plated) | 2 | 1.6.LS140032 |
| 5 | | Hexagon flat-head screw | M4*8 (chrome plated) | 4 | 1.6.LS840012 |
| 4 | PP-0900D01 | Displaying-board | PMMA-6.0T | 1 | |
| 3 | PP-0900A03 | Displaying-board fastener | SPCC-1.2T | 2 | |
| 2 | PP-0900A02 | Right displaying-board supporting-iron | SPCC-1.2T | 1 | |
| 1 | PP-0900A01 | Left displaying-board supporting-iron | SPCC-1.2T | 1 | |
| SN | Drawing No. | Name | Materials/specifications | Qty | Note |

6.11 POP components (PP-1000000)

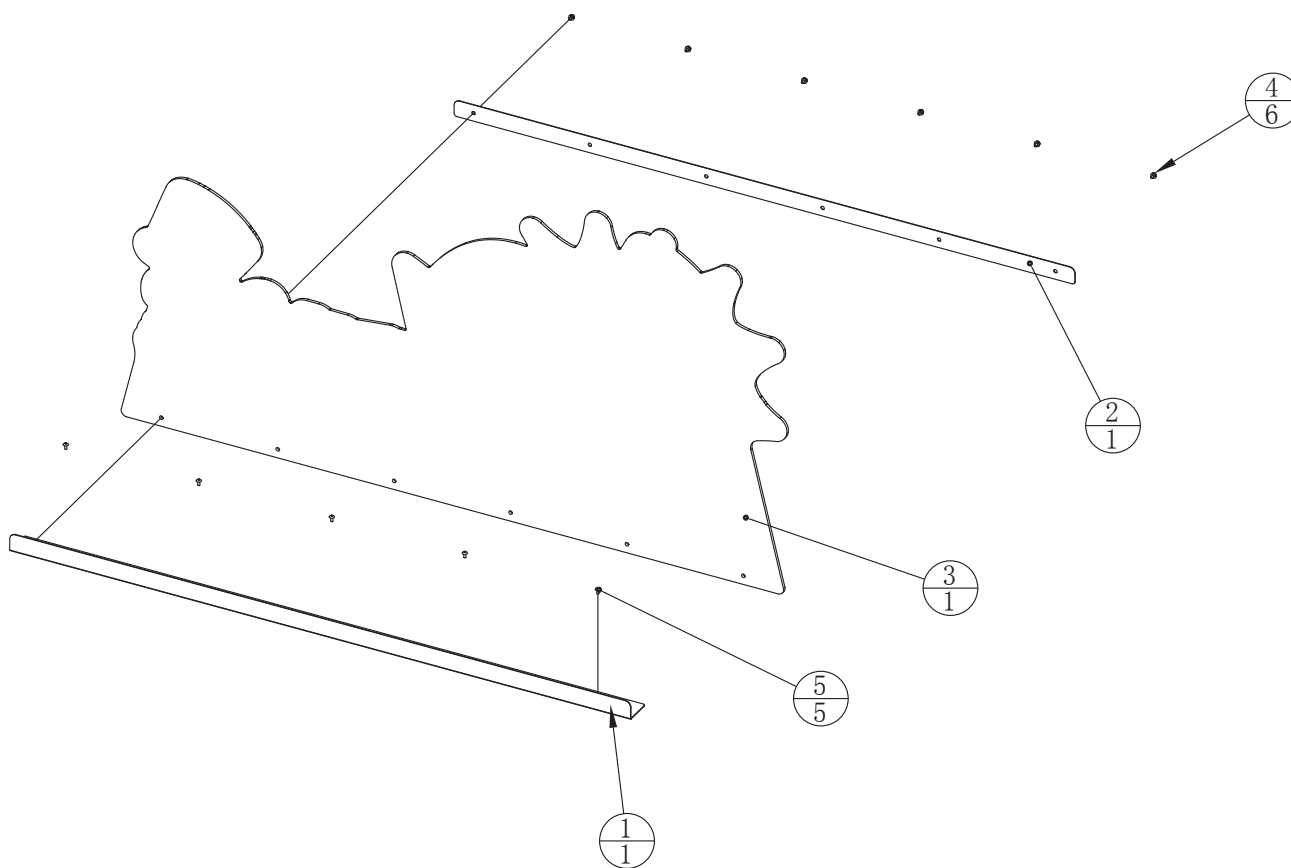

| | | | | | |
|----|-------------|---------------------------------|--------------------------|-----|--------------|
| 5 | | Hexagon flat-head screw | M4*8 (chrome plated) | 5 | 1.6.LS140032 |
| 4 | | Cross round-head combined screw | M4*6 (chrome plated) | 6 | 1.6.LS840012 |
| 3 | PP-1000D01 | POP plate | Andy board | 1 | |
| 2 | KC-1000A02 | POP pressure plate | SPCC-1.2T | 1 | |
| 1 | KC-1000A01 | POP fixed-iron | SPCC-1.5T | 1 | |
| SN | Drawing No. | Name | Materials/specifications | Qty | Note |

7. Printing List

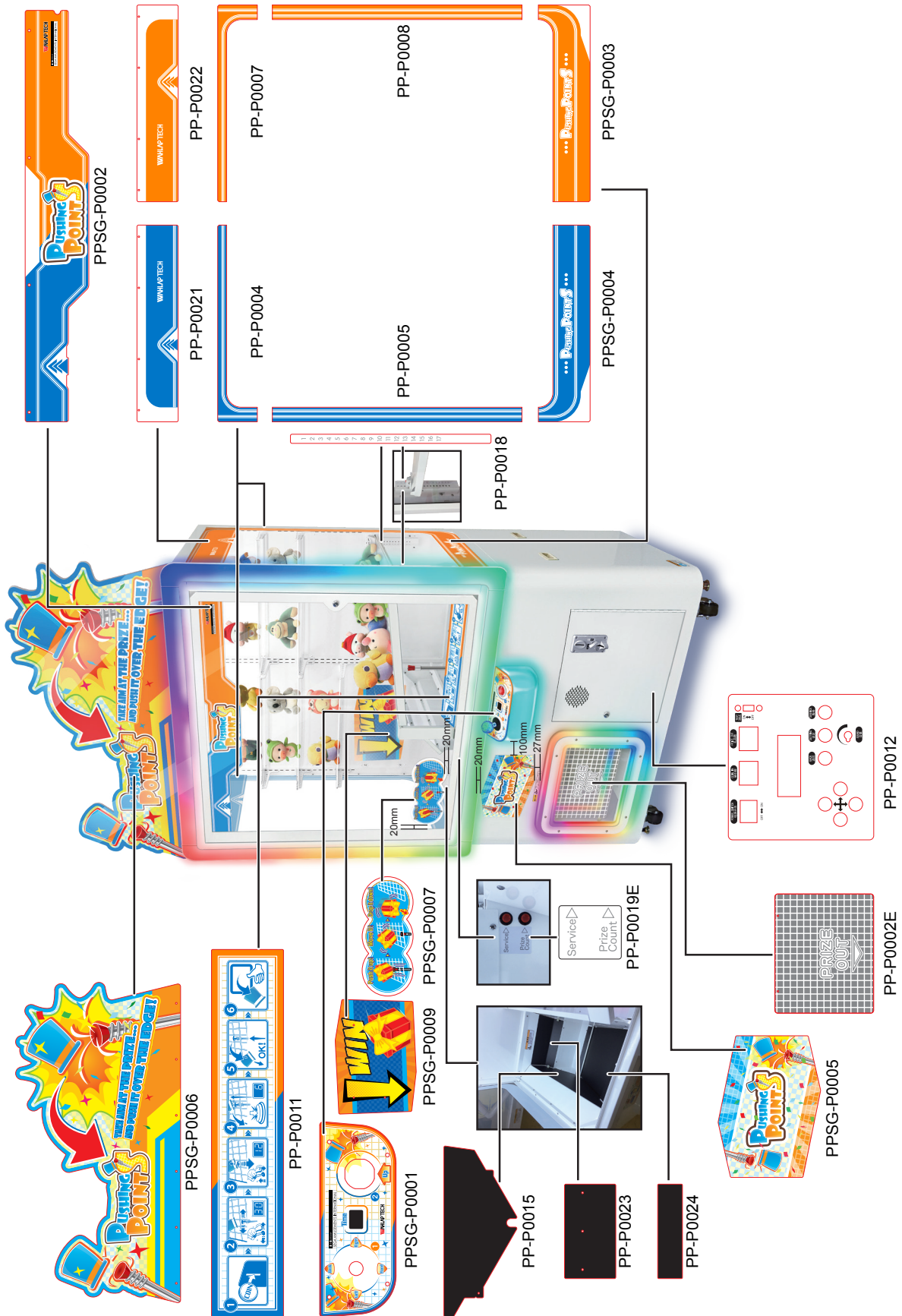

8. Wiring Diagram

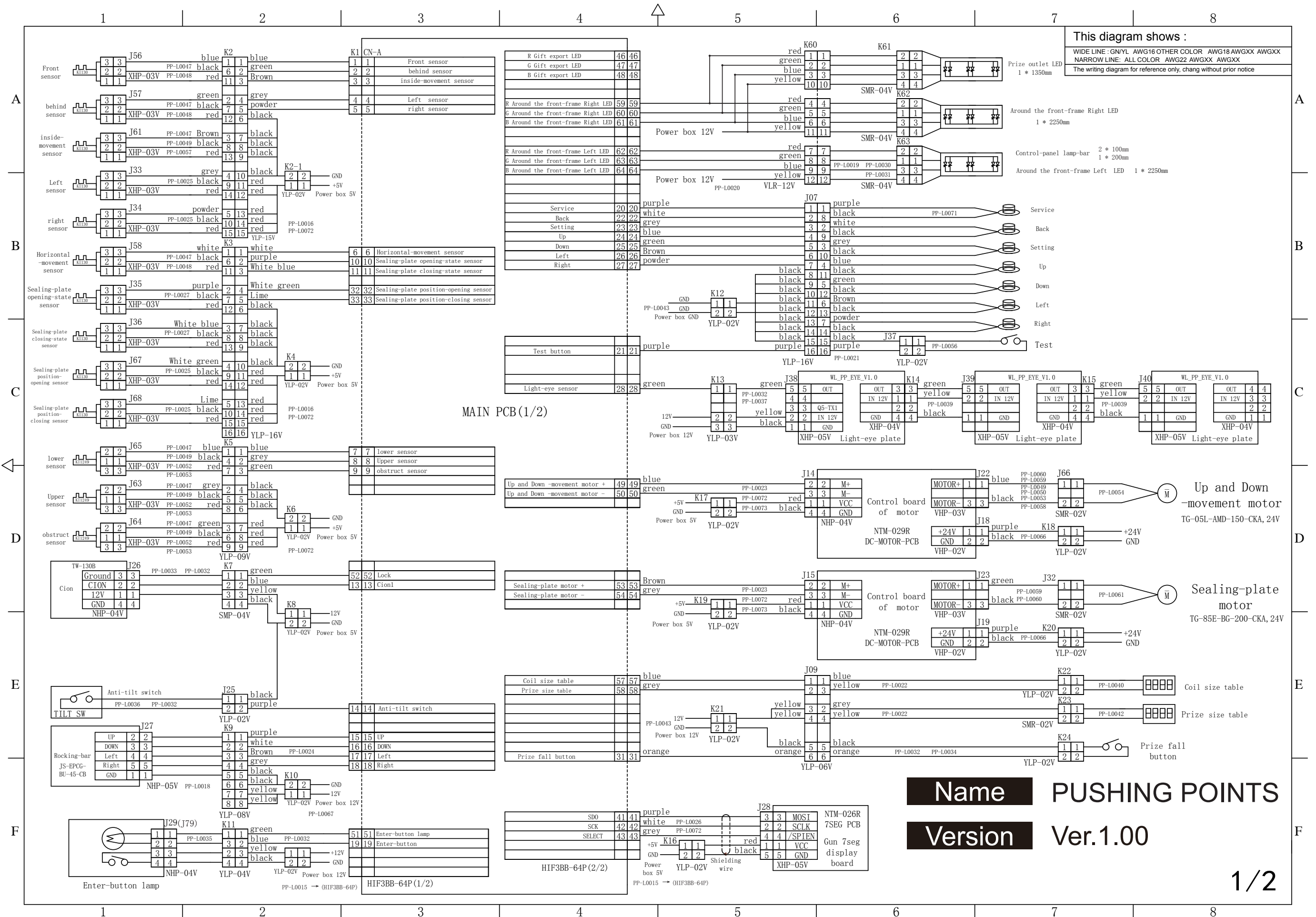

This diagram shows :
 WIDE LINE : GN/YL AWG16 OTHER COLOR AWG18 AWGXX AWGXX
 NARROW LINE : ALL COLOR AWG22 AWGXX AWGXX
 The writing diagram for reference only, chang without prior notice

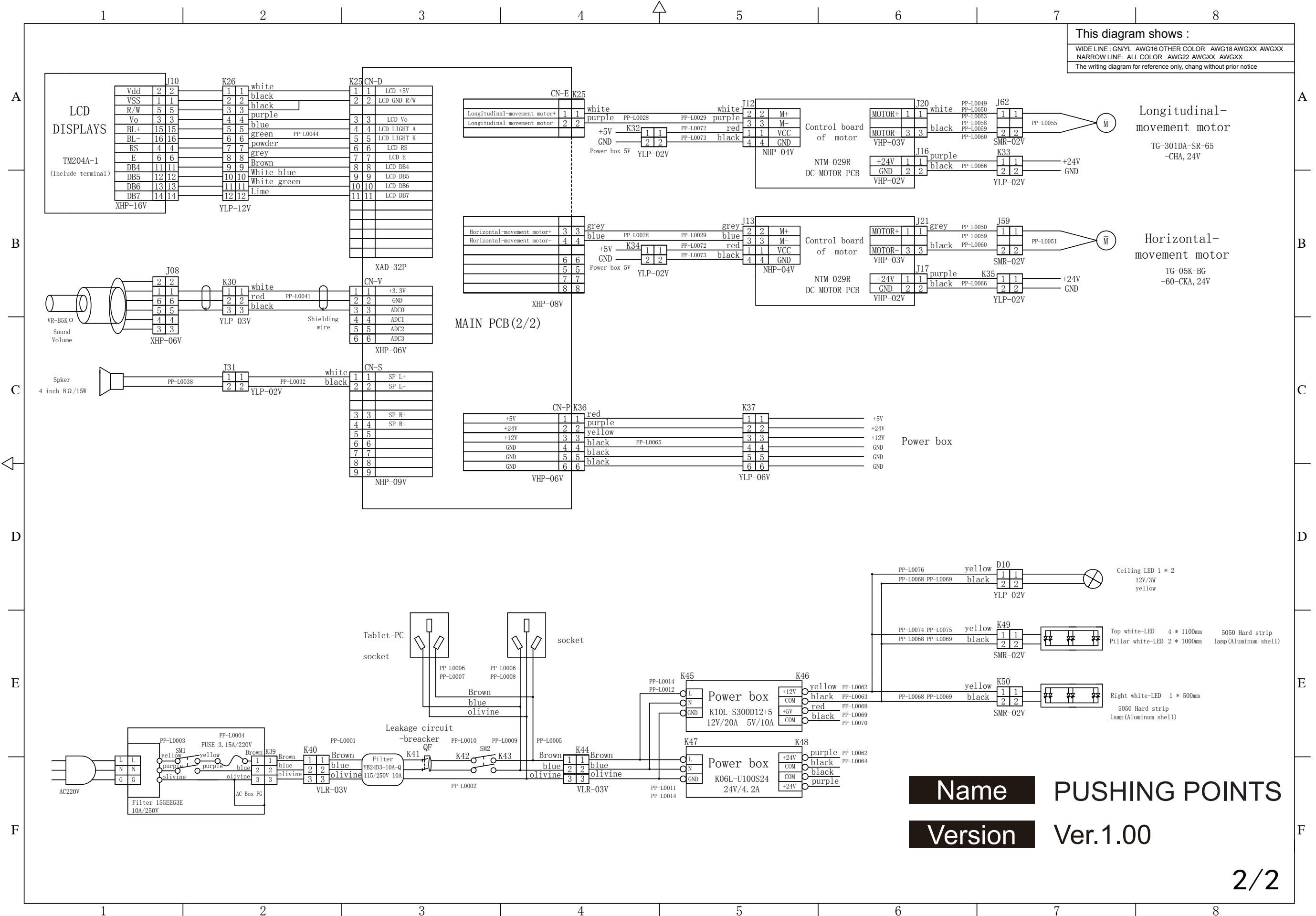

Name PUSHING POINTS
Version Ver.1.00

SPARES AND SERVICE CONTACT INFORMATION

-SEGA TOTAL SOLUTIONS-

42 Barwell Business Park
Leatherhead Road
Chessington
Surrey
KT9 2NY
United Kingdom

Contact: +44 (0) 208 391 8060
Option 1 for Spares, Prize, and Sales
Option 2 for Technical, Warranty, and Repairs



-PLAY IT AMUSEMENTS-

870 Lively Blvd
Wood Dale
Illinois
60191
United States of America

Main/General: 847-364-9787
Part Sales: 224-265-4287
Technical Support: 224-265-4283



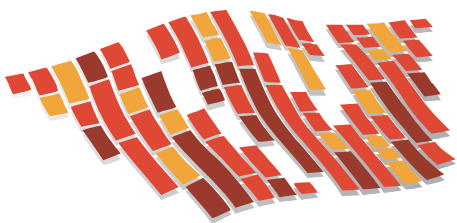

PPSG-P0012



Ver. 1.00

WAHLAP TECH

DISTRIBUTED BY
SEGA AMUSEMENTS INTERNATIONAL

※ The specifications and operation instructions in this Manual are subject to change without notice for reasons such as performance.