



OWNER'S MANUAL

Ver.2.01



WARNING

- For safety reasons, please read the manual first before plugging in machine.
- Please keep this manual properly for convenient reference as needed.

About This Manual

Thank you for purchasing this product.

The manual describes how to install, set up, use and maintain the product. The main purpose of the manual is to instruct how to operate the product correctly and safely. Please follow all the safety and warning instructions in the manual to avoid personal injury and product damage.

This product may only be maintained by a technician. A technician mainly refers to a person who has obtained a certificate of senior middle school related to mechanical engineering, electrical engineering or at a level equal to that of technical senior middle school graduates, and is engaged routinely in the maintenance, management, repair of amusement machine.

When transferring the ownership of this product, be sure to provide this manual with the machine.

For further information about the game and repair (including consumables), please contact our company.

© GuangZhou Wahlap Technology Limited All Rights Reserved.

Unauthorized reproduction of this document or any of its contents in any form is strictly forbidden.

Table of Contents

About This Manual

1. Safety Precautions.	1
1.2 Placing Site	1
1.3 Safety Precautions	2
1.4 Precaution during Play	3
1.5 Transporting and Moving	3
1.6 Installing and Placing	4
1.7 Caution & Warning Stickers	5
2. Product Description.	6
2.1 Product Specification	6
2.2 Overview	7
2.3 Spare Parts	8
2.4 Shipment List	9
2.5 Packing List	12
2.6 Install Direction	13
2.7 Position of seat rear-plastic components	14
2.8 Windpipe	15
2.9 Warranty	17
3. Game Description.	18
3.1 Appearance Design	18
3.2 Game introduction	18
3.3 How to play	18
3.4 Linking & Networking for Cabinets Information	19
4. Test and Setting.	20
4.1 Game Description	20
4.1.1 GAME FEATURE	20
4.1.2 GAME CONTENT	21
4.2 Game FLOW	24
4.2.1 Front-End MENU	24
4.2.2 In-Game MENU	31
4.2.3 Back-End MENU	37
4.3 Online Patching	40
4.3.1 UI	40
4.3.2 Common Cases in Patching	40
4.4 USB Drive Patching Readme	43
4.4.1 How to Boot from USB for SRG USB Patching	43
4.4.2 For SRG version 1.5.12 or before	45
4.4.3 For SRG version 1.5.14 or after	47
4.4.4 For SRG versions Downgrading	47

4.4.5 Invalid Cases of USB Drive Patching	48
4.5 Operator MENU	51
4.5.1 Arcade Operation Mode	51
4.5.2 Languages	52
4.5.3 Master Volume	52
4.5.4 Idle Volume	53
4.5.5 “Clear Coins” function	53
4.5.6 First Round Coins	54
4.5.7 Second Round Coins	55
4.5.8 Winner Bonus	55
4.5.9 Challenger Join Time	56
4.5.10 Auto Pedal	56
4.5.11 Game Time	57
4.5.12 Clock	57
4.5.13 Income	58
4.5.14 Record	58
4.5.15 Sound Testing	59
4.5.16 Light Testing	60
4.5.17 Button Testing	61
4.5.18 Calibration Steering (Auto)	62
4.5.19 Calibration Foot Pedal and Boost (Manual)	63
4.5.20 Video Split Number	64
4.5.21 Video ID	65
4.5.22 Patch	65
4.5.23 IO	66
4.5.24 Reset	66
4.5.25 Save	67
4.5.26 Game-Play Screen Information	68
5. Maintenance and Service	69
5.1 Maintenance and service	69
5.2 Part Replacement	70
5.2.1 Replacement of camera	70
5.2.2 Replacement of light-box soft lamp	70
5.2.3 Replacement of button components	71
5.2.4 Replacement of accelerating-handle components	72
5.2.5 Replacement of the pedal components	72
5.2.6 Replacement of coin acceptor	73
6. Assembly	74
6.1 Assembly tree diagram	74
6.2 General assembly(1)	75
General assembly(2)	76

6.3 Front-frame assembly	77
6.3.1 Lower-frame assembly	78
6.3.2 Lower-frame fan assembly	79
6.3.3 Woofer assembly	80
6.3.4 Subwoofer assembly	81
6.3.5 Power-pack assembly	82
6.3.6 Pneumatic valve components	83
6.3.7 Control-card assembly	84
6.3.8 Air compressor assembly	85
6.3.9 Air compressor power-pack assembly	86
6.3.10 Host assembly	87
6.3.11 LCD glass assembly	88
6.3.12 LCD assembly	89
6.3.13 Filter assembly	90
6.3.14 Fluid control valve assembly	91
6.3.15 Sink components	92
6.4 Seat-base assembly	93
6.4.1 Seat-base assembly	94
6.4.2 Airbag assembly	95
6.4.3 Seat airbag assembly	96
6.4.4 Seat active-plate assembly	97
6.4.5 Pedal assembly	98
6.4.6 Limiting components (1)	99
6.4.7 Limiting components (2)	100
6.4.8 Motor assembly	101
6.5 Seat-component assembly	102
6.5.1 Seat assembly	103
6.5.2 Seat-belt buckle-end assembly	104
6.5.3 Seat-belt roll-end assembly	105
6.5.4 Vibrating speaker assembly	106
6.6 Seat backrest assembly	107
6.7 Light-box assembly	108
6.7.1 Light-box LED assembly	109
6.7.2 Eye LED assembly	110
6.7.3 Camera assembly	111
6.8 Coin-acceptor assembly	112
6.8.1 Service-board components	113
6.9 Control panel assembly	114
6.9.1 Emergency-stop button assembly	115
6.10 Start button assembly	116
6.11 Pedal component assembly	117
6.11.1 Accelerator component assembly	118

6.11.2 Brake-component assembly.....	119
6.12 Rear-plastic assembly.....	120
6.12.1 Tail acryl 1 assembly.....	121
6.12.2 Tail acryl 2 assembly.....	122
6.12.3 Rear-plastic assembly.....	123
6.12.4 Rear-side plastic (1) assembly.....	124
6.12.5 Rear-side plastic (2) assembly.....	125
6.13 Back-door assembly.....	126
6.14 Steering-wheel assembly.....	127
7.Printing Pattern	128
8.Wiring Diagram	129
9.After-sales Service	133

1. Safety Precautions

1.1 Warning Stickers

In order to avoid injury to related people and damage to property, please observe the followings:

PLEASE READ FIRST

- The following marks can be used to indicate the magnitudes of risk and damage caused by ignorance or improper operation:



means “may result in serious injury or death”



means “may result in minor injury or property damage”

Serious Injury: refers to the situations in which hospital treatment or long-term treatment will be accepted because of losing sight, getting hurt, getting burnt, electric shock, fracture or intoxication.

Minor Injury: refers to the cases that there is no need to go to hospital or accept long-term treatment.

Property Damage: refers to the damage of house, facility, or hurt of livestock and pet

1.2 Placing Site

Warning

- please make sure the place line has been grounded before product installation, setup, testing, operation or repair
- This machine is designed for indoor use only. Never install the machine outdoors. Meanwhile, please avoid the following locations indoor:
 - Direct sunlight, water leakage, damp and high temperature places.
 - Near Flammable, volatile, or/and dangerous substance.
 - Slope, unstable places or locations subject to frequent vibration.
 - Near emergency exit, fire extinguisher or similar equipment.
- The rear part has the vent for heat emission from PC or screen. Don't place anything nearby to avoid game failure.
- Provide a space of minimum 30cm between the rear of the machine and the wall for good ventilation and heat emission

1.3 Safety Precautions

The owner shall pay attention to the followings when placing, checking and repairing machine to insure player's security and avoid damage:

Warning

- please check the voltage is 110V or 220V before the machine connects to the power supply, or it may cause a fire or electric shock.
- Make sure to plug the game into 110V or 220V main outlet to avoid fire and electric shock.
- Make sure to turn off the power when performing maintenance and service to avoid electric shock or short circuit.
- Do not unplug or plug the plug instantly.
- Don't touch the power plug with a wet hand to avoid electric shock.
- Don't expose the power cord/grounding line on the passageway. Failure to do this will damage the power cord, causing electric shock or short circuit.
- Don't lay anything near the power cord to avoid fire.
- Do not pull the power cord when unplugging, please hold the plug to avoid power cord damage, causing fire or electric shock.
- In case of power cord damage, please contact the local distributor for replacement
- Only use fuse and spare parts specified by our company
- Connect the connector firmly and tighten the screws.
- Do not dismount, replace or convert the product without our permission in order to avoid damage and human injury due to improper operation.
- Check and maintain the machine regularly.
- Keep "Warning stickers" clean and legible. Replace it immediately when the words are not legible or the dirt can't be removed.
- Please contact our service center when performing any work that is not described in this manual, and follow the instruction provided.

1.4 Precautions during Play

Caution

- In order to avoid injury and accident during play, the following people shall not play the game:
 - People who are injured or less mobile.
 - Person with poor health condition, such as hypertension or heart disease.
 - Person wearing high-heeled or slippery shoes.
 - Person who can't touch the pedal.
 - Pregnant woman, drunk people.
- When a player feels uncomfortable during play, remind the person to have a break, or stop playing.
- Make sure the player reads the warning labels and other indications, and plays in accordance with the instructions to avoid accidents such as electric shock and short circuit.
- Bystander shall not operate any button when the player is playing the game to avoid unnecessary trouble.

1.5 Transporting and Moving

Caution

Transporting

- When transporting the machine with an elevator, be sure to employ "Lift Point" to prevent accident and damage to the machine.
- To prevent movement when transporting the machine on a vehicle, please fix the casters and fully retract the adjusters. Failure to do this may cause damage to the machine.
- When carrying the machine with a forklift, be sure to insert the fork to fork position and lift stably. If not, it may cause accident and damage to the machine.
- The glass and LCD screen are fragile. Avoid violent vibration or shock when transporting.

Moving

- Before moving the machine, unplug the power plug to prevent accident. Don't damage the cord.
- Pay attention to the obstructions and uneven surface when moving the machine to prevent accident and damage to the machine.
- Fully retract all adjusters before moving to prevent accident and hazard.
- Make sure to use at least two persons to conduct the above work to avoid accident and injury
- Pay attention to the moving direction, see fig.



1.6 Installing and Placing

Pay attention to the following when placing the machine.

Caution

- Place the machine on the flat and slip resistant area.
- Use the adjusters to fix the machine (See diagram 1)
 1. Loosen the nuts for the adjusters (clockwise), tighten the bolts with a wrench (clockwise).
 2. Tighten the nut firmly (counter clockwise) and fix it well.

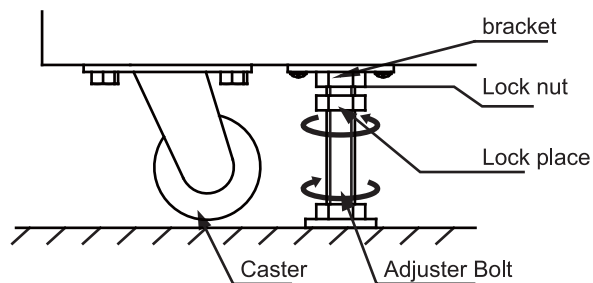

Diagram (1)

- Provide a space of minimum 30cm between the rear of the machine and the wall for good ventilation and heat emission (See diagram 2 and diagram 3).

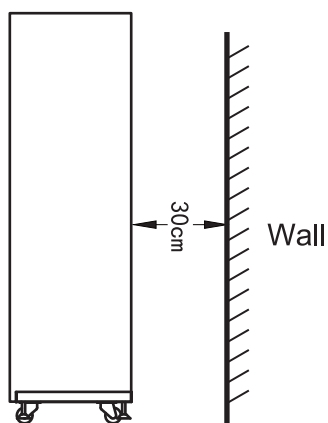

Diagram (2)

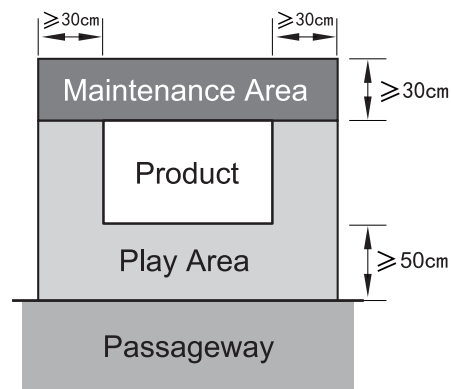
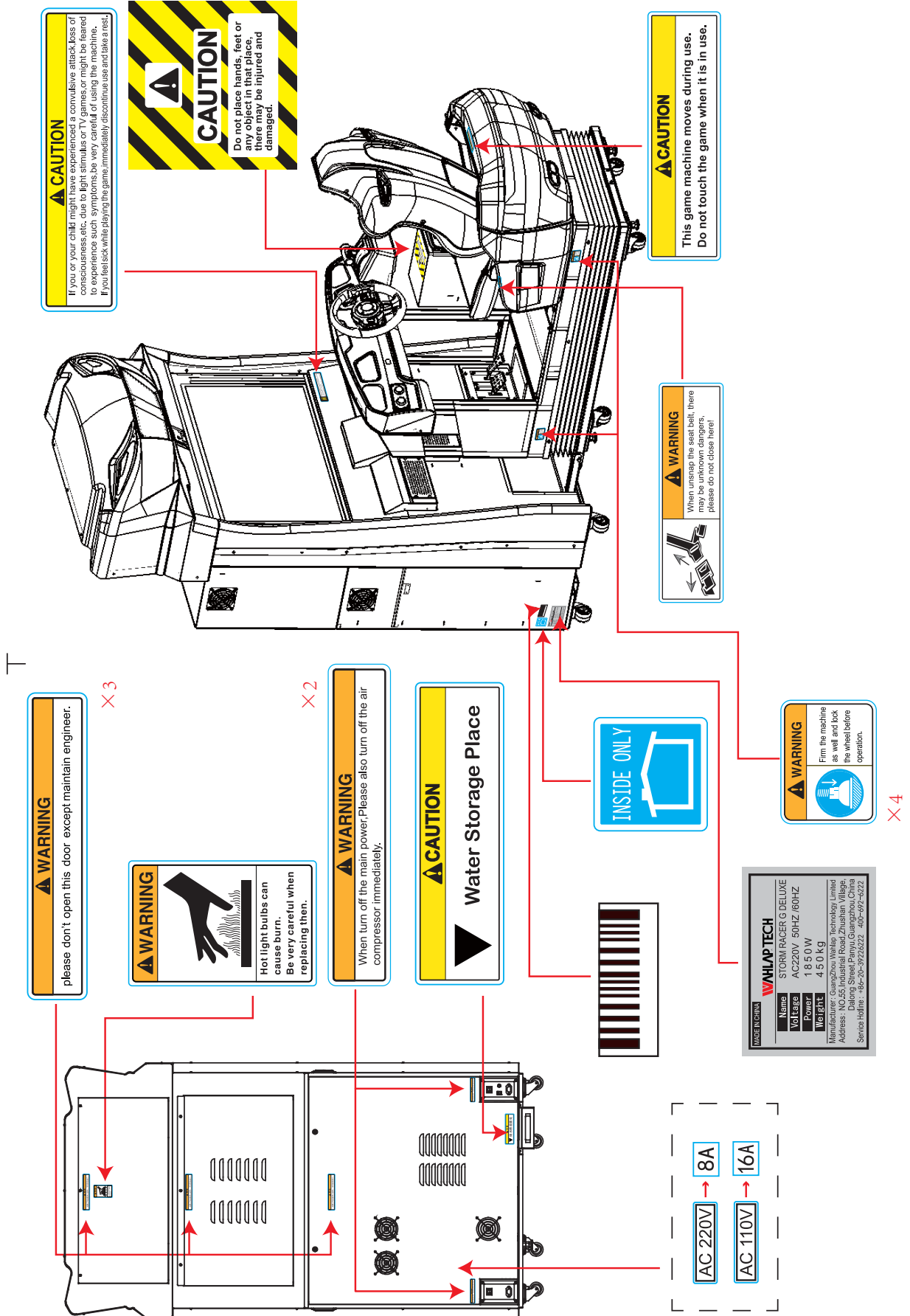
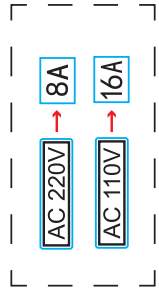

Diagram (3)

1.7 Caution & Warning Stickers



WHLAP TECH
 STORM RACER G DELUXE
 AC220V 50HZ/60HZ
 1850W
 450 Kg
 Manufacturer: Guangzhou Wailian Technology Limited
 Address: NO.55 Industrial Road, Zhuoshan Village,
 Dailong Street, Panyu, Guangzhou, China
 Service hotline: +86-20-39226222 400-697-0222



2. Product Description

2.1 Product Specification

■ Location	Indoor Only
■ Dimension	1280(W)×2360(D)×2260(H)
■ Rated Voltage、Frequency	AC220V 50HZ /60HZ
	AC110V 50HZ /60HZ
■ Power Consumption	1850W
■ Weight	450kg
■ Temperature Range	5~40 °C

*110V voltage can be set through the transformer and fuse.Please contact the distributor for details.
NOTE:The contents herein described are subject to change without notice.

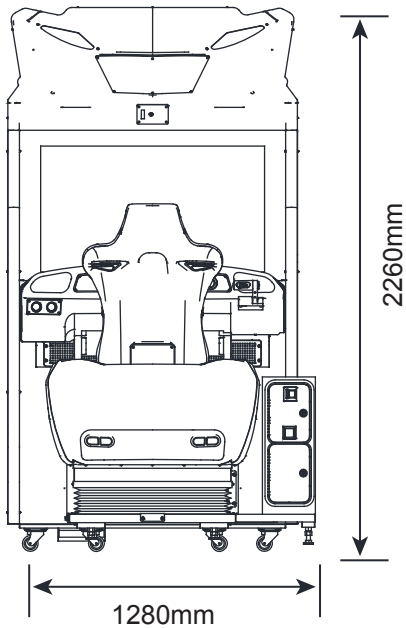

■ Front View

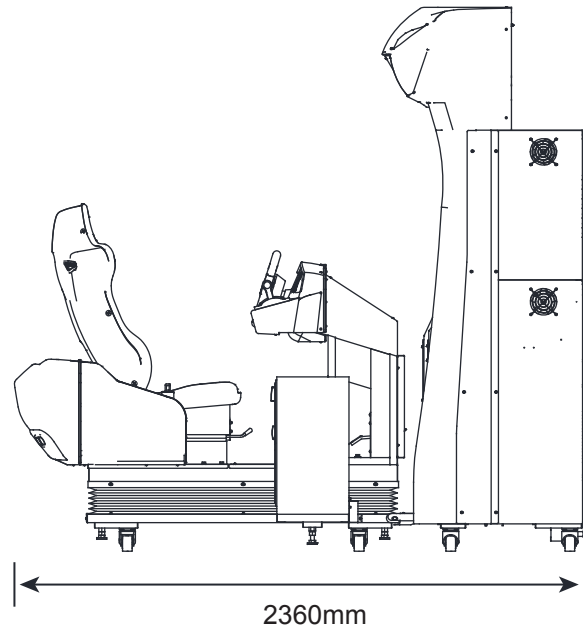

■ Side View

2.2 Overview

■ Side View

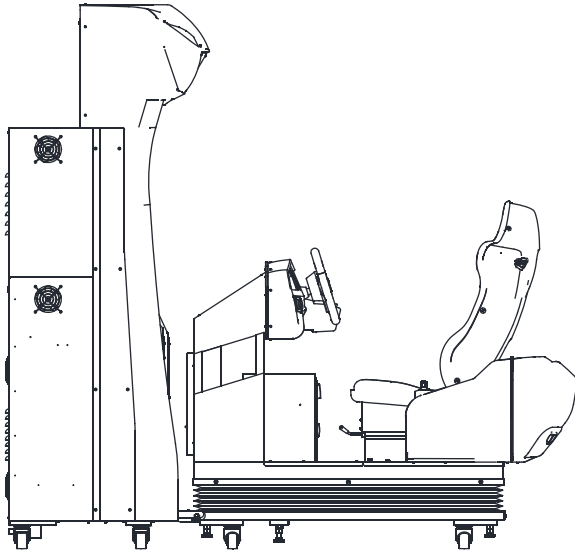

■ Rear View

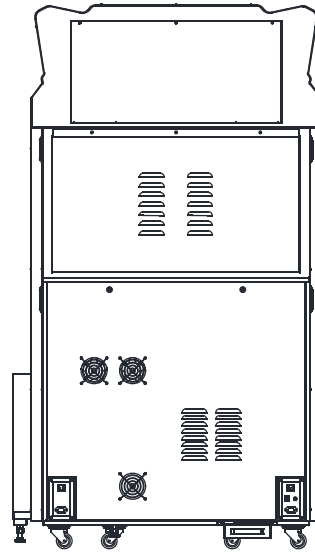

■ Top View

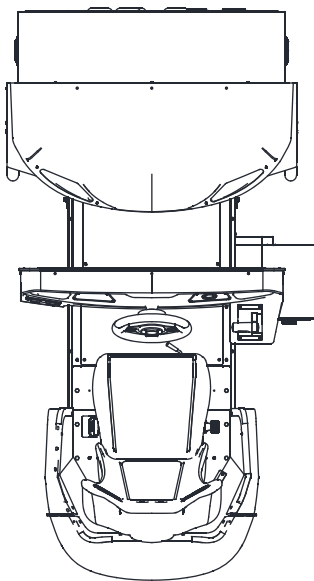

■ Bottom View

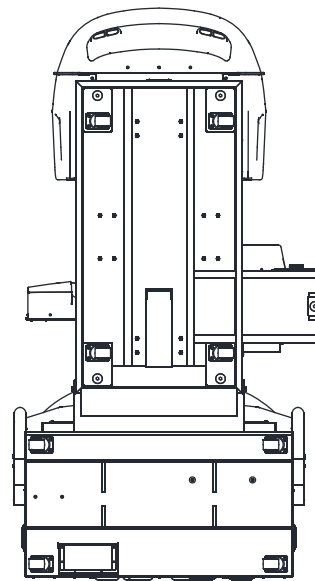

2.3 Spare Parts

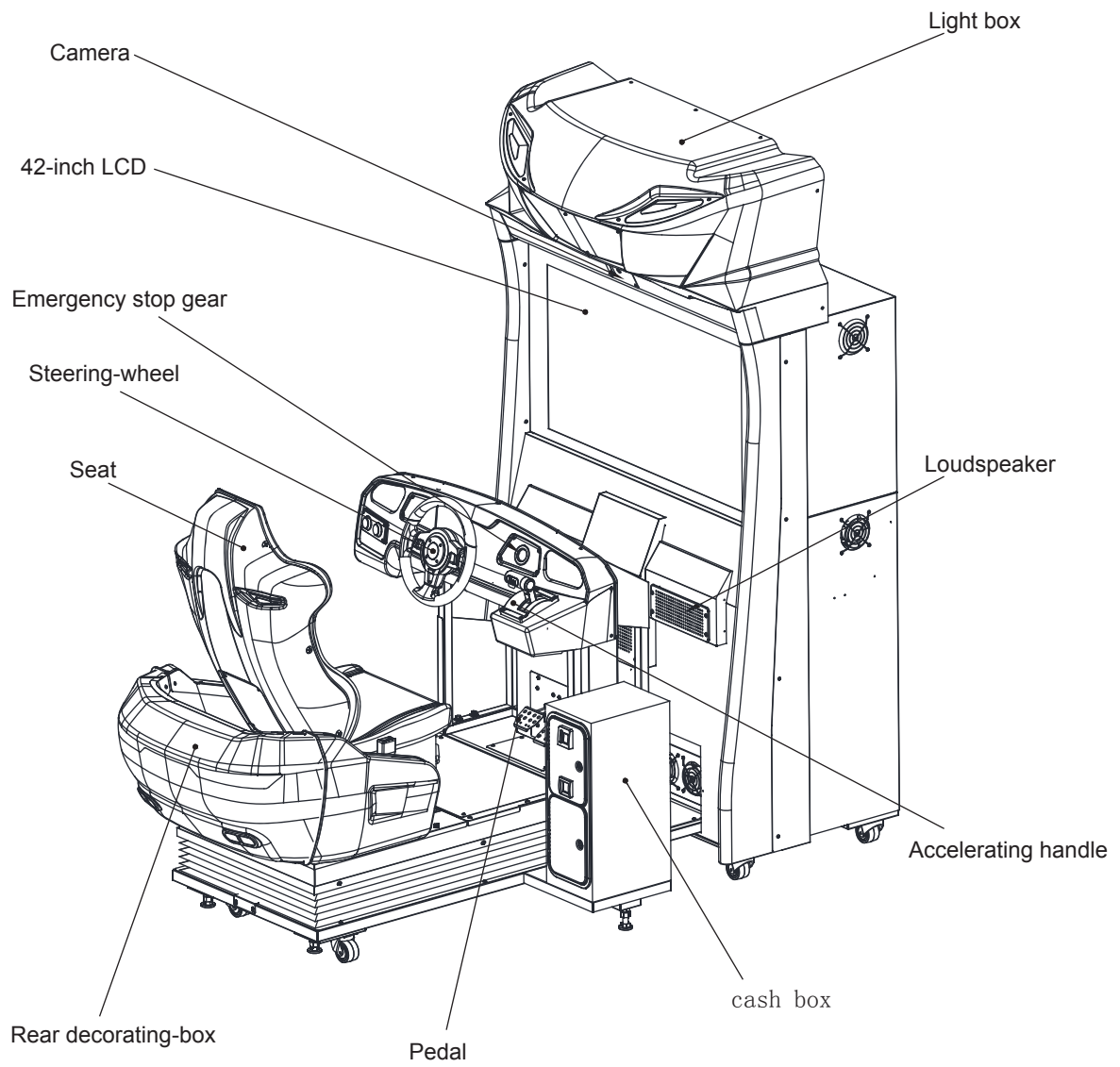

2.4 Shipment List

■ Packing Carton 1

产品名称 Product Name		
箱体重量 Box Weight	260 kg	
箱体尺寸 Box Size	810 x 1280 x 1890 mm (W) (D) (H)	
箱体备注 Box Remark	荧幕主件	
C/NO.	1/3	本页材料数

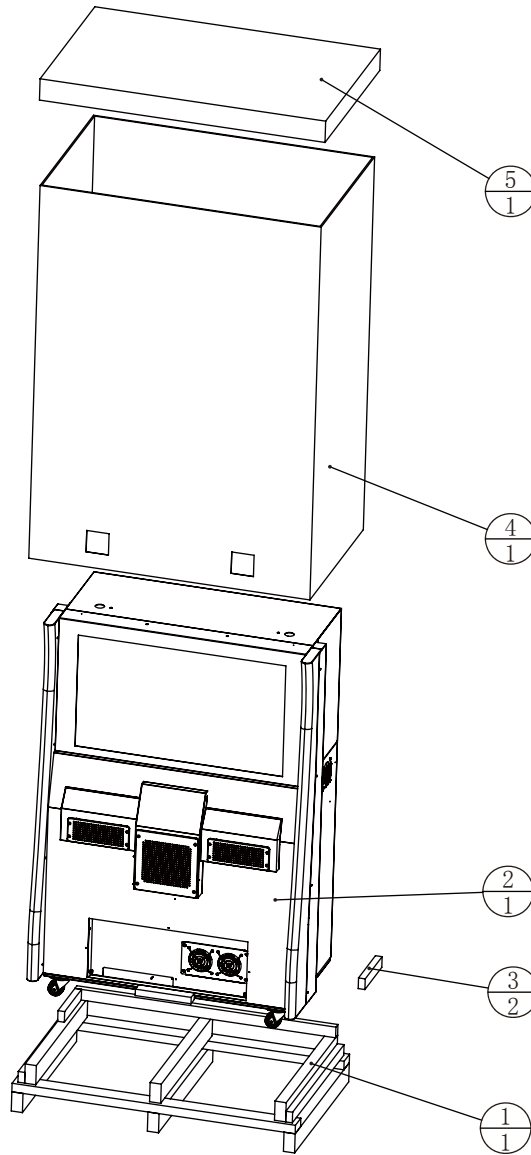

5	SRH-9902E04		2C 850g T-7	1	1.9.ZX031620
4	SRH-9902E03		2C 850g T-7	1	1.9.ZX020784
3	SRH-9902E02		wood 30*50*250	2	1.9.MB0234710
2				1	
1	SRH-9902E01		wood	1	1.9.MB011980
No.	Draw No.	Name	Material/Spec.	Qty.	Product Code

■ Packing Carton 2

产品名称 Product Name		
箱体重量 Gross Weight	250 kg	
箱体尺寸 Gross Size	1580 x 1160 x 1610 mm (W) (D) (H)	
箱体备注 Remarks	座位主件、附属品箱	
C/NO.	2/3	零件数量表

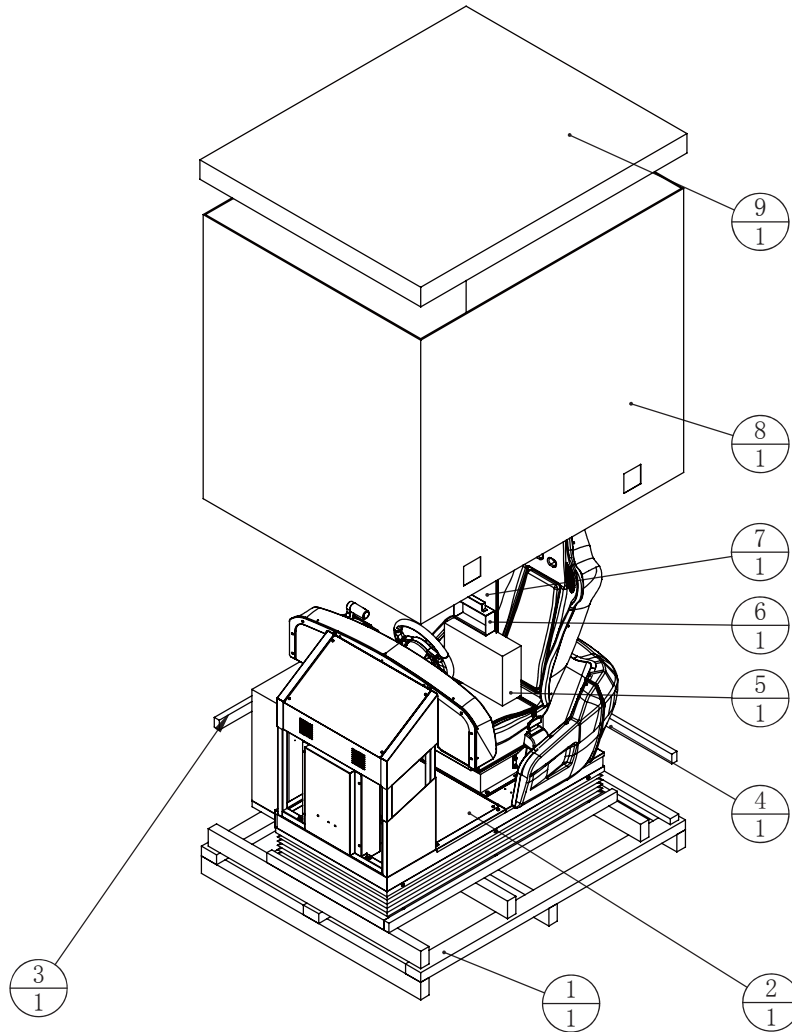

9	SRH-9901E05		2C 850g T-7	1	1.9.ZX031610
8	SRH-9901E04		2C 850g T-7	1	1.9.ZX021570
7	SRH-0000A12	Connecting iron cover plate	SPCC-1.5T	1	1.1.WA16C00310
6	SRH-0115A02	Flume		1	1.1.WA16C00310
5				1	
4	SRH-9901E03		Wood 30*50*694	1	1.9.MB0234700
3	SRH-9901E02		Wood 30*50*814	1	1.9.MB0234690
2		Seat-component		1	1.3.NA02B00120#
1	SRH-9901E01		Wood	1	1.9.MB011970
NO.	Draw No.	Name	Material/Spec.	Qty.	Product Code

■ Packing Carton 3

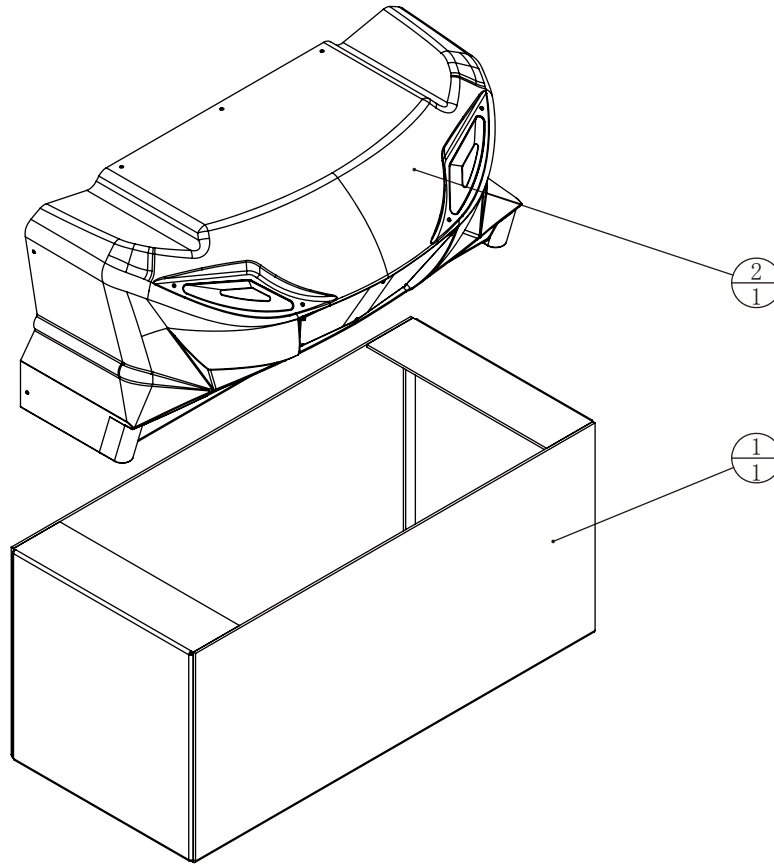

产品名称 Product Name	S1000R 6 FACER Deluxe	
箱体重量 Gross Weight	30 kg	
箱体尺寸 Box Size	570 x 1250 x 570 mm (W) (D) (H)	
箱体备注 Remarks	灯箱主件	
C/NO.	3/3	※ 原裝材料規格

2	SRH-0500000	Light-box assembly		1	
1	SRH-9903E01		2C 850g T-7	1	1.9.ZX040110
No.	Draw No.	Name	Material/Spec.	Qty.	Product Code

2.5 Packing List

Please check the following items after purchasing our product. If any part missing or damaged, please contact our sales person!

Description	Specification	Quantity	Remarks
Network cable - 10M	AMP 5M	1	
AC cable	3m (1.0m m ²)	2	
Hex head screw	M8*16 (black)	4	
Hex head screw	M8*20 (black)	4	
Spring washer	M8 (black)	8	
Flat gasket	φ8*φ16*2.0 (black)	8	
Truss screw	M5*12 (black)	4	
The three combination screw round head	M5*12 (black)	10	
key	5555 key	2	
User's manual - english		1	

2.6 Install Direction

■ Step 1

1. Remove 2 M8*20 hexagonal screws (including washers, spring washers) on the top of the fixed parts 1, rotate part 1 to the specified position; Use 2 removed hexagonal screws to connect the seat and screen; Connect the wire and windpipe Use 4 M5*12 flat-head screws to fix.

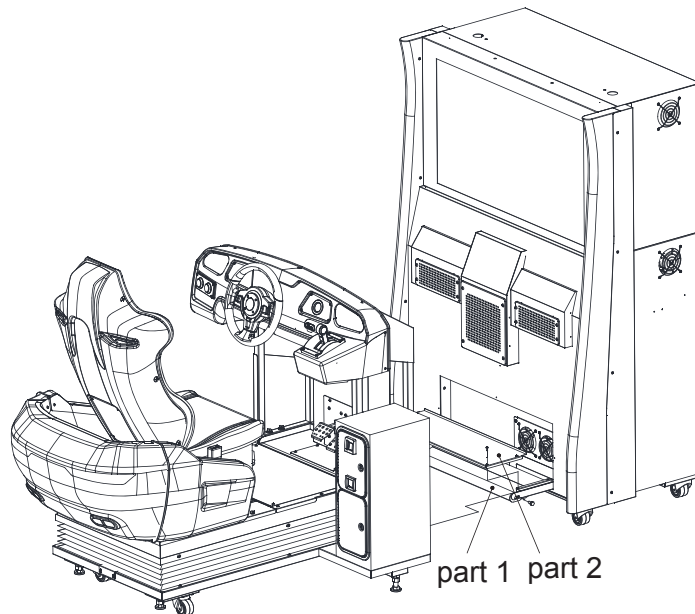

2. Remove 3 M4 x 25 combination screws on the fixed-part 3, remove part 3; Use 4 M8*20 hex screws (including washers, spring washers) to fix part 4; Connect the wire; Re-fix part 3 back to its original position .

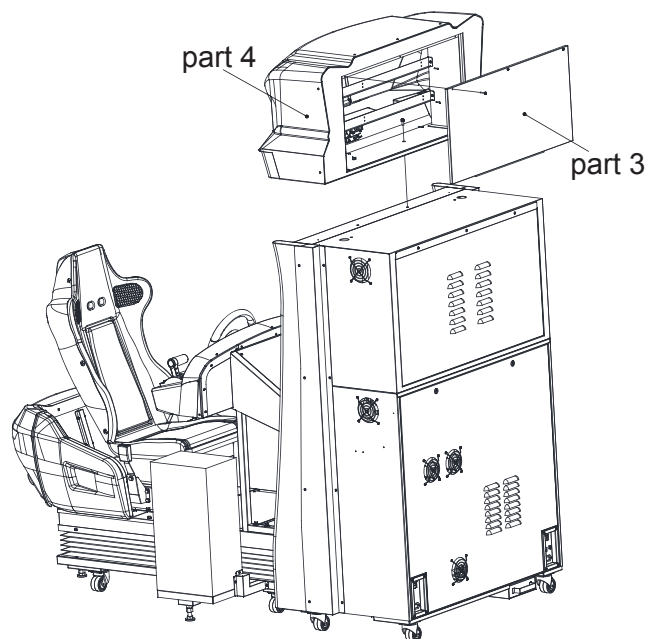

2.7 Position of seat rear-plastic components

Before the game machine is switched on, follow these steps to adjust seat rear-plastic components :

1. After unpacking, Seat rear-plastic component position is as shown in figure 1.
2. Remove all the screws to fix the plastic components and move the plastic components to the position as shown in figure 2.
3. Tighten all the screws against the holes (The rest of the screws are in the coin-acceptor box).
4. Remove A to check whether the wire is normal or not. After completion, fix the small door at A.
5. Start the game machine.

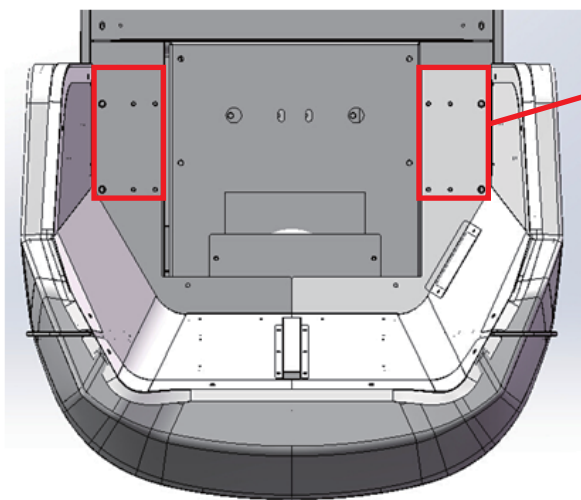

Remove all the screws within the scope of around frame and move the plastic components to the position as shown in figure 2

(figure 1)

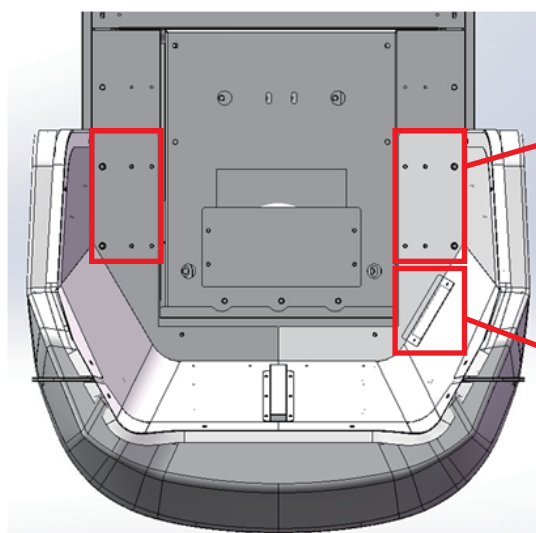

Tighten all the screws

Remove A to check whether the wire is normal or not

(figure 1)

2.8 Windpipe

After unpacking, check whether the windpipe positions installed on the seat and screen are consistent with the positions as shown in (figure 1) and (figure 2).

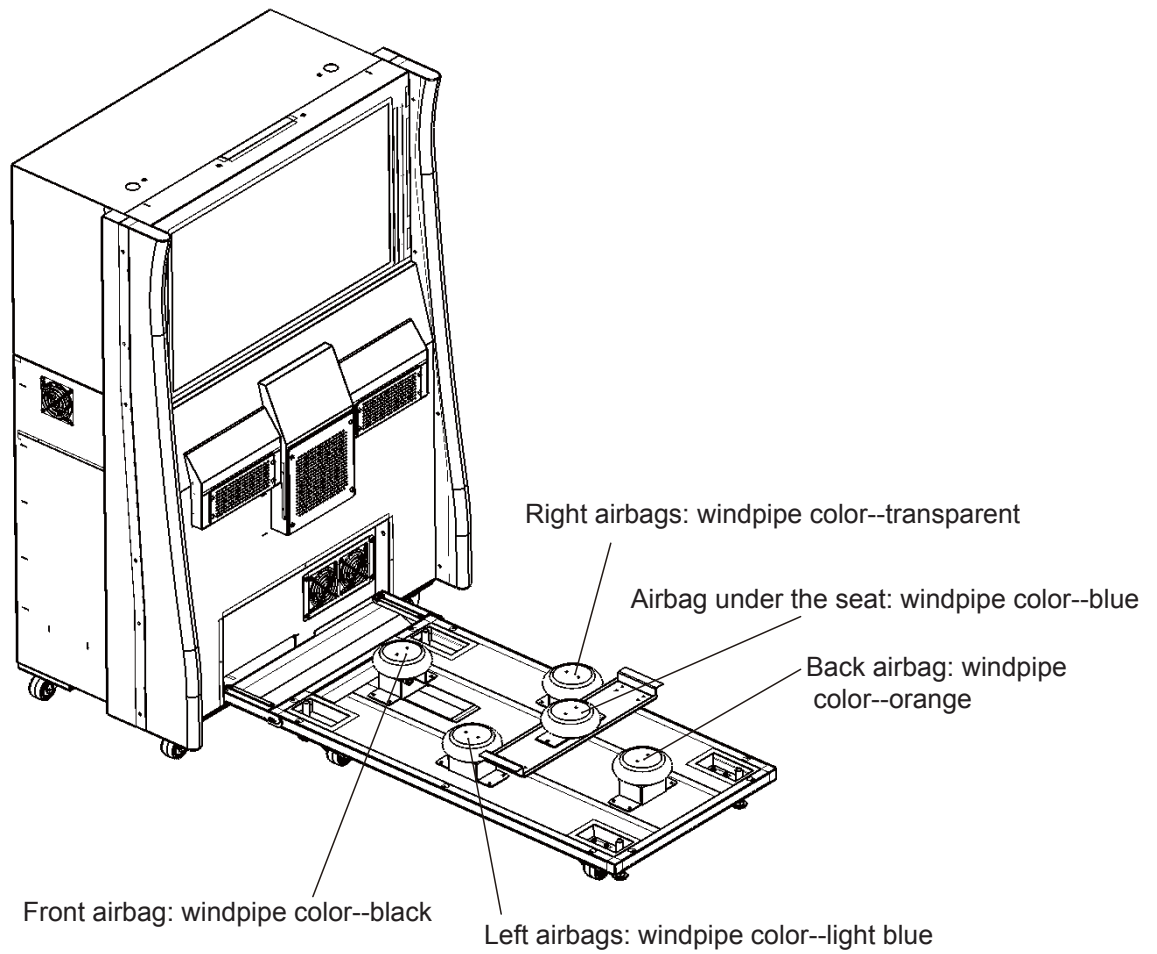

(figure 1) seat windpipe

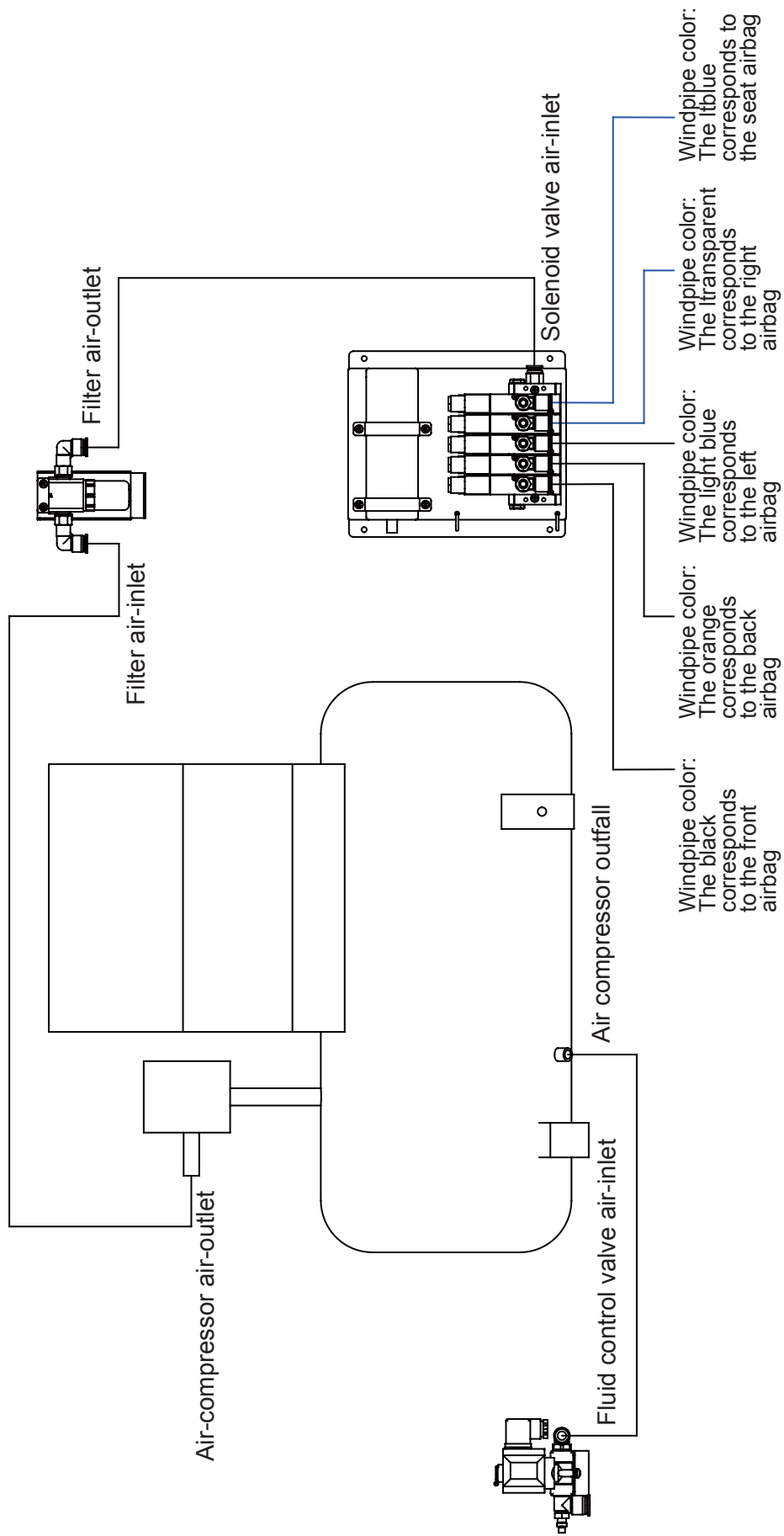

(Figure 2) Windpipe on the screen

2.9 Warranty

■ Scope

- Inquiry regarding product can be assisted for free.
- The warranty scope for consumables and durables may differ from product to product. Please contact our after-sales service center for detailed information. The right of final interpretation is reserved.

■ Exclusive

- Damage caused by force majeure such as god will.
- Failure caused by carelessness, such as water contact, falling down, toppling, knocking.
- Failure caused by disobeying the instructions in this manual.
- Failure caused by operating the machine on inappropriate site.
- Change the original design and configuration for the game without notice.
- Failure to perform regular service and clean.
- Failure to fix the product in line with the manual's requirement.
- Malfunction or part damage caused by electromagnetic interference other electronic equipments generated.

■ Non-warranty Consumables

- Light tube and bulb
- Button lamp and switch
- Fragile items
- Solenoid
- Other spare parts

3. Game Description

3.1 Appearance Design

This game is a racing game. Use a 42-inch high-resolution screen, which can provide the high-grade image quality.

Its appearance is concise and easy. Its frame is mainly the black metal frame, with the white plastic components. Although it only has little decorative stickers, its white plastic components make it more beautiful and have the player fully feel the fun of the racing car. The game lighting is blue. Matching with the plastic and acrylic components, it can all the more attract the attention of the player.

Another feature of this racing car is sporty. The player can feel the simulated true sense of the racing car in the process of playing the game.

The seat size can be adjusted according to the requirements, which can make the player more comfortable to play the game, and at the same time, the seat plastic components can be adjusted according to the requirements in order to improve the security.

3.2 Game introduction

Storm racer G is a racing-car game with the pneumatic function. It has a 42-inch LCD monitor which has 720DP high-definition picture and the picture is 60 frames per second. The game has 6 featured scenes and 12 tracks. The game is divided into the elementary game, intermediate game and advanced game with 4 difficulties. The game can be played by 8 players at the same time. The racing car in the game is very strong. The racing car can be controlled by the highly-sensing controller and newly-accelerating system to run in different track. With the pneumatic system, the game machine will tilt, pitch and swing with the racing car running, which makes the player to have the feeling that he/her is really sitting in a racing car.

3.3 How to play

1. Use the traditional steering wheel + pedal, with the featured accelerating handle at the same time.
2. Playing method: After the coin is inserted, press START button or tread the accelerator to enter the track-selection screen, rotate the steering wheel to select the track. After the track is selected, use the same method to select the racing car. After START button is pressed, the racing car is ready to depart and the accelerator is treaded to get the racing car run. The accelerating status will be shown at the bottom right corner of the picture. When the certain throb-values are collected, the accelerating handle can be pushed forward to start the racing-car acceleration.
3. It is provided the perfect security protection system such as seat belt and emergency stop button in order to ensure the safety of the player.

3.4 Linking & Networking for Cabinets Information

In the below figure, it shows how the cabinets (no. of cabinets from 2 to 8) should be linked up with the router by cables separately.

Note: Please make sure all games are in the same version in order to be linked with.

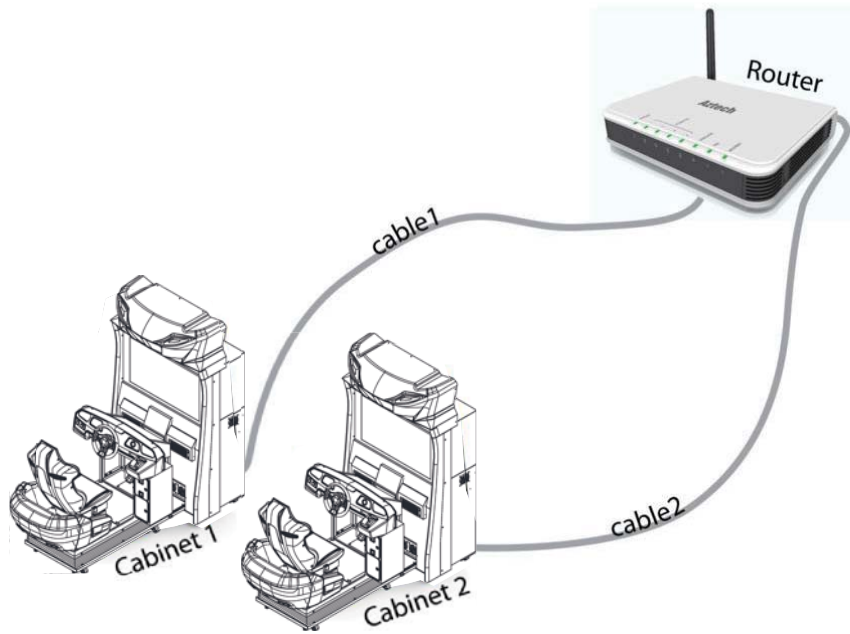

In the router, the LAN ports are where cable(s) to PCS should be inserted; the WAN port is where the Internet cable should be inserted.

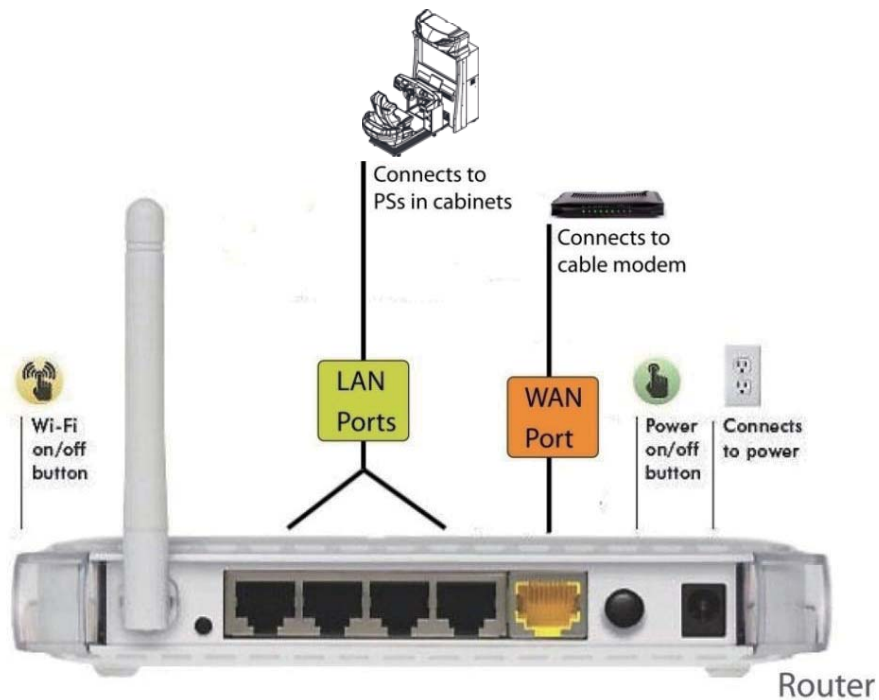

4. Test and Setting

4.1 Game Description

4.1.1 GAME FEATURE

- Up to 8 Players (LAN)
- HD 720p Resolution
- 37”inches screen
- 60 Frames per Second; High Sense of Speed with Fluent Game Play
- Online Patching /Upgrade Support
- Cloud-based Server
 - Advantage: Stable Internet Speed for All Regions
- Classic Arcade Racing Style
- Auto/Manual Drift Mode for Beginner/Expert
- Competitive AI
- Full Force Feedback Steering Wheel
- Unique Throttle for Boost
- 4.1 Sound System
- Vibration Speakers under the Seat simulate Car Response
- Intense Game Play Embedded with Camera Kit
- Compatible Low Maintenance Cost PC with Sandy Bridge Standard
- Total of 12 Tracks with 6 Hidden Tracks; Total of 14 Cars with 7 Hidden Cars
- When one player’s car crushes and turns over other cars, the player will get rewards;
when one player’s car is crushed and turned over by other cars, the player will get penalty.
This can further raise the irritation during racing

4.1.2 GAME CONTENT

Tracks

There are total of 12 tracks in 4 difficulties: Beginner, Advance, Expert and Extreme (appeared in Reverse Tracks only).The game will begin with 6 Tracks –

- Circuits Of Rivers
- Ruin Temple
- The Heights
- Pearl City
- Stone Forest
- Snow Mountain

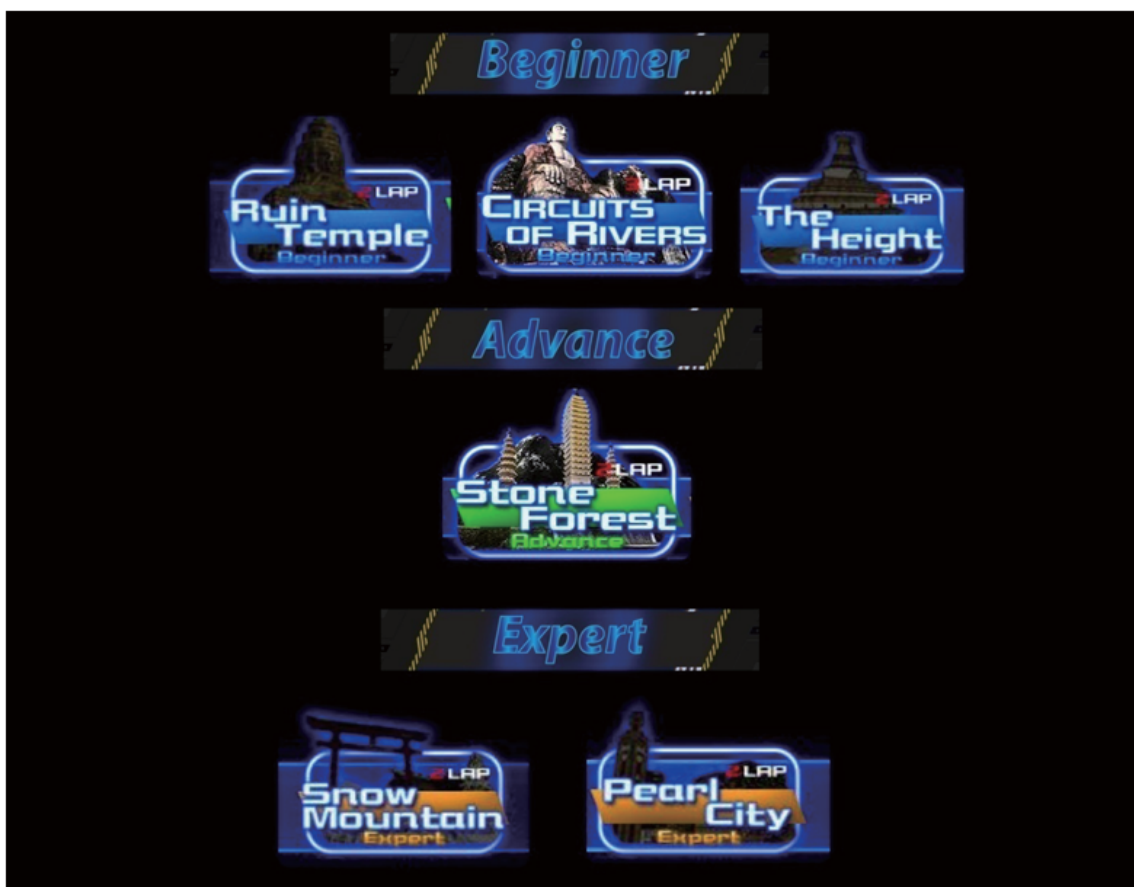

6 Hidden Tracks could be unlocked by counting how many G Coins the player has gained in every game.

How to Unlock Hidden Tracks?

An energy bar is shown to show the player how many G Coins he has gained in the last game and how many more he has to achieve in order to unlock certain hidden tracks.



Single-Play Mode:

- A new hidden track will be unlocked by counting how many G Coins the player has gained in every game.

Multi-Play Mode:

- A new hidden track will be unlocked by counting how many G Coins by all players have gained in every multi-play game.

For example: 4 players finished a game- track Circuits of River

Player	Player 1	Player 2	Player 3	Player 4	Total	Unlock Track
Position	1 st	2 nd	4 th	6 th	110	Circuits of River
G Coins gained	50	30	15	15		

Cars

There are a total of 14 cars. The game will begin with 7 Main Cars.

7 Hidden Cars could be unlocked by random.

7 Main Cars are in different levels: Beginner, Intermediate and Advance and Expert.



How to Unlock Hidden Cars?

Single-Play Mode & Multi-Play Mode:

- A new hidden car will be unlocked in every game by random.
- 2 new hidden cars will be unlocked by The Champion in every game by random.



4.2 Game FLOW

4.2.1 Front-End MENU

Scene 1: Logo

Logo of Wahlap and Insoft will be appeared in the beginning.

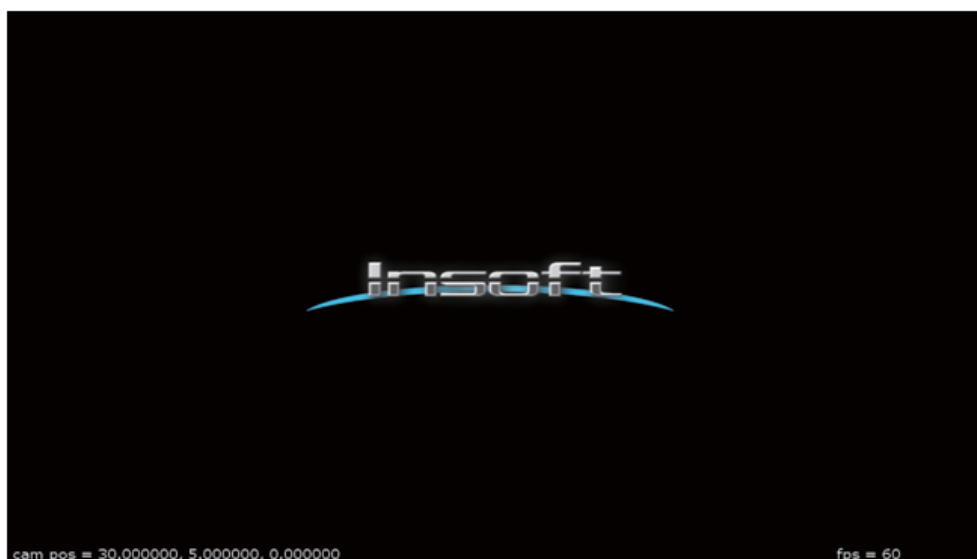

Scene 2: Intro Video (with learning video)

The Game Introduction video will be played. Learning videos will be appeared in between.

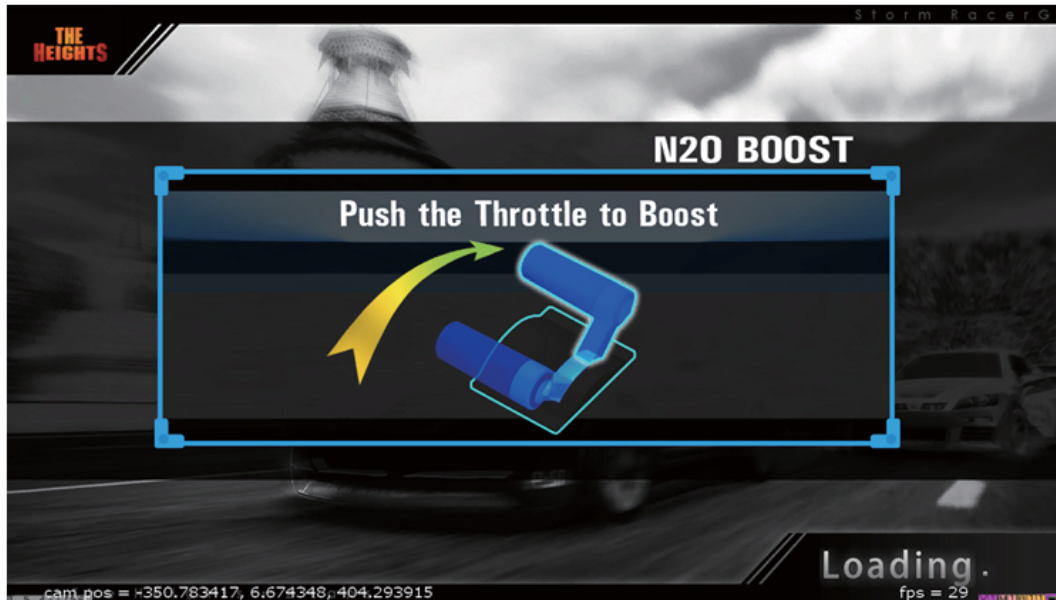

Scene 3: Insert Coins

A screen of insert coins will appear to ask player to start the game.



Scene 4: Warning

A warning screen will appear after game starts for 5 seconds.



Scene 5: Fasten Seat Belt Reminder

Before player can select the track, a reminder screen will appear to ask player to fasten the seat belt. The screen will appear in a shorter time when seat belt is fastened.



Scene 6: Selecting Track

In the Track Selection screen, there are a total of 12 tracks with 6 hidden tracks (to be unlocked). Tracks are divided into four difficulty levels: Beginner, Intermediate, Superior and Extreme, allowing players to challenge different difficulty levels.

Please use the steering wheel to turn left and right to select and then press the [START] button or step on the accelerator.



Scene 7: Selecting Car

In the Car Selection screen, there are a total of 14 cars with 7 hidden cars (to be unlocked). Cars are divided into three levels: Entry, Medium and Professional, drift and turn Bay deceleration is different at different levels.



Cars are presented in four different numerical rating to show their unique performance advantages:

- 1: Boost Gauge (that can influence the thunderous value, the value of thunderous acceleration forces)
- 2: Maximum Speed (The maximum speed in the general case)
- 3: Steering (there will be some advantage in a variety of Bay Road on the track)
- 4: Acceleration (speed of accelerate and overcome the rugged track)

Please use the steering wheel to turn left and right to select and then press the [START] button or step on the accelerator.

Each racing car could be set Drift Mode as: Automatic Drift OR Manual Drift

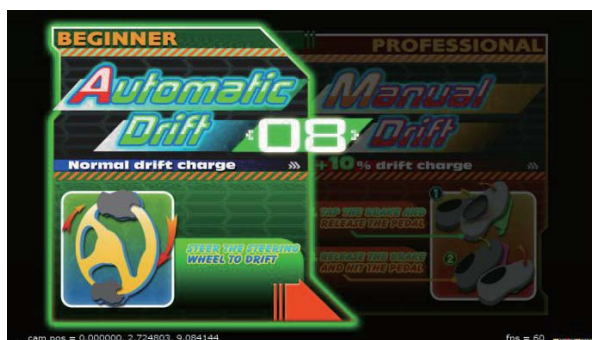

Scene 8: Camera

Players will be invited to take icon photos which will be displayed in the race.

A photo is shot after a count down from 5 to 1.



...4...3...2...

Scene 9: (Only suitable for Competition Mode) Multi-Players Race Status Screen

In a multi-player race, after selecting tracks and cars, a status screen will pop up to show the data of each player of this race (cars selected, own photo icons, level of players).

Players who are still selecting cars will be displayed as “Getting Ready” instead of his own data. The selected track will be displayed in the middle as well.



Scene 10: Loading Screen

Learning Messages will be shown as loading screen.

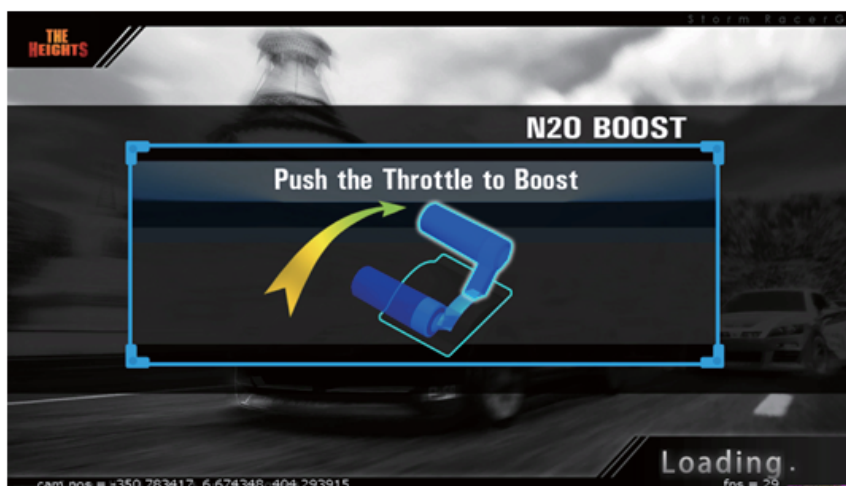

4.2.2 In-Game MENU

Notice: After the race has started, once the emergency STOP button is pressed or once the seat belt is detected as unfastened, the motion feature will be stopped until the game is over.
Notice: During the game, motion will stop after unfastening seat belt for 3 seconds.

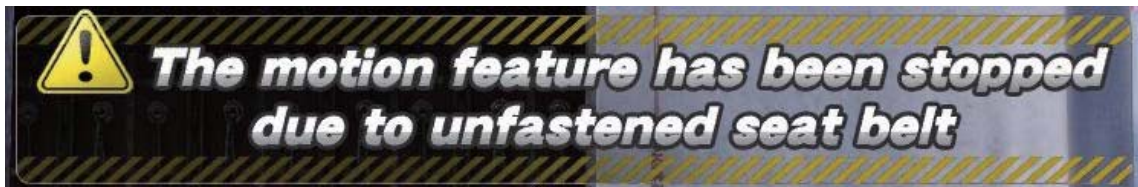

Scene 11: In-Game Screen

Game START

Race starts at once right after the loading is finished.



UI Screen (I)

When the Race begins, data of the Race will be displayed around four sides of the screen.



1. LAP: No. of Laps

2. TIME: Count Down (in seconds)

3. POSITION: Ranking of player

1-3 will change to RED in color in the last 60 seconds of the race.



4. Map:

▲ represents Player

● represents other Players

UI Screen (II)

When the Race begins, data of the Race will be displayed around four sides of the screen.



5. Display of curve player will pass.
6. Data of player(s) in front.
7. Display of all players ranking.
8. Tips of reminding player to turn on the Nitrogen Meter Boost.
9. Data of player(s) behind.
10. Nitrogen Meter.

Status of Nitrogen Meter Boost: Normal, Charging and Full (from left to right)

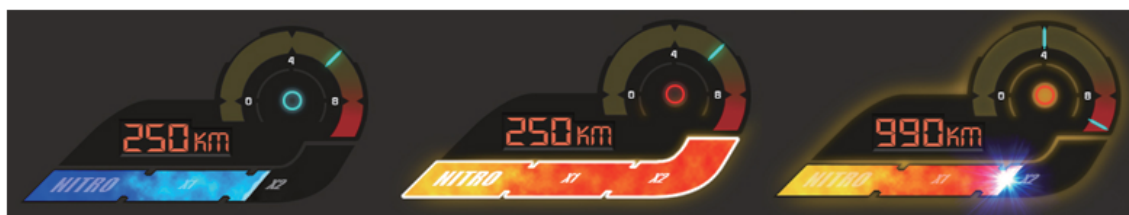

UI Screen (III)

“Boost Charger” status is shown at the bottom centre, displaying the status of Boost Amount.

Display 1: Boost Charger - Drift Charge.



Display 2: Boost Charger - Boost Maximum



Display 3: Boost Charger - Out of N2O



Display 4: Brackets - Using Boost (The Red Brackets drops, representing amount of N2O is dropping when using boost)



Scene 12: FINISH Game

The race is over when time is up.
Position of the player will be shown.



4.2.3 Back-End MENU

Scene 13: Race Ranking

After the race is finished, a Final Ranking of all players will be shown.



1. Ranking of the tournament
 - Levels: S、A、B、C
 - S as the Supreme ranking; C as the lowest ranking
2. Tournament Data
 - a. Photo of player
 - b. Selected Car
 - c. Total Time
3. Medals obtained

Scene 14: Unlocked Item

A page of unlocked items will be shown.

Players can show if any cars or tracks have been unlocked successfully in the race they just finished.

New track is unlocked:



New car is unlocked:



Scene 15: Continue

-For Winner: Bonus Round (Discount Game)

Winner of the tournament will be awarded to continue the game with discount.



-For Other Players: Game Over, Continue to Play

Players will be invited to continue the race to challenge and become the Winner.



4.3 Online Patching

4.3.1 UI



- Game Version: means local game version
- Latest Version: means latest version in server after connected to server
- Please wait for 5 seconds to start game if no patching or successful patching
- Please wait for 10 seconds to start game if any error is occurred in patching

4.3.2 Common Cases in Patching

Case 1 - Already Latest Version

Under the below screen, game is at the latest version, no need to do patching.
Please wait for 5 seconds to start game.

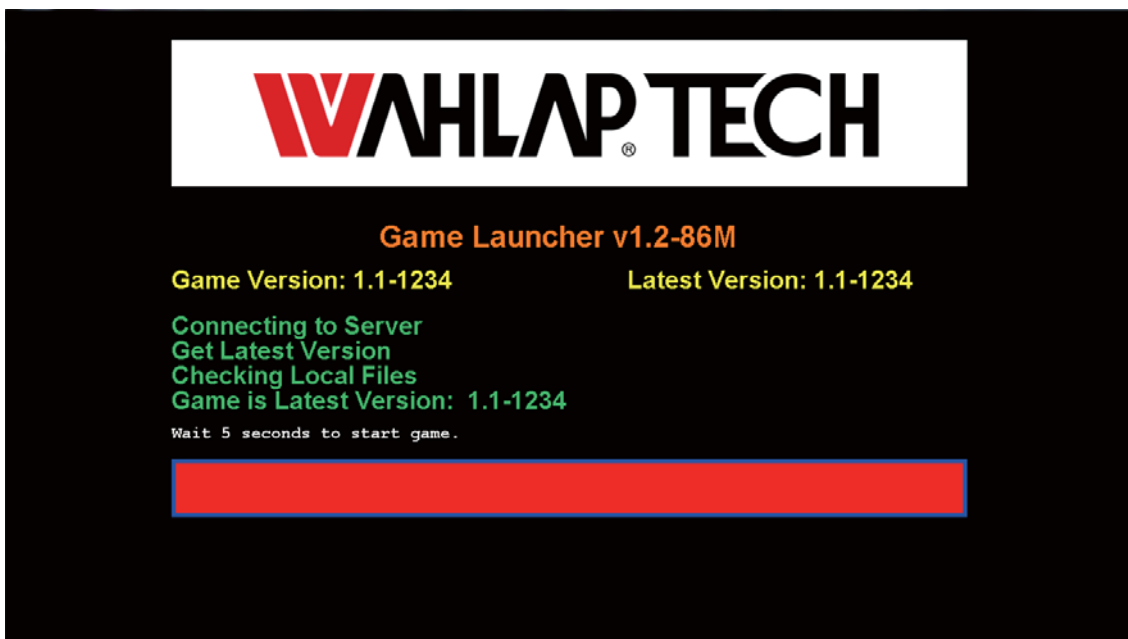

Case 2 – Patching Successful

Under the below screen, game is patching to the latest version and patching is successful. Please wait for 5 seconds to start game.

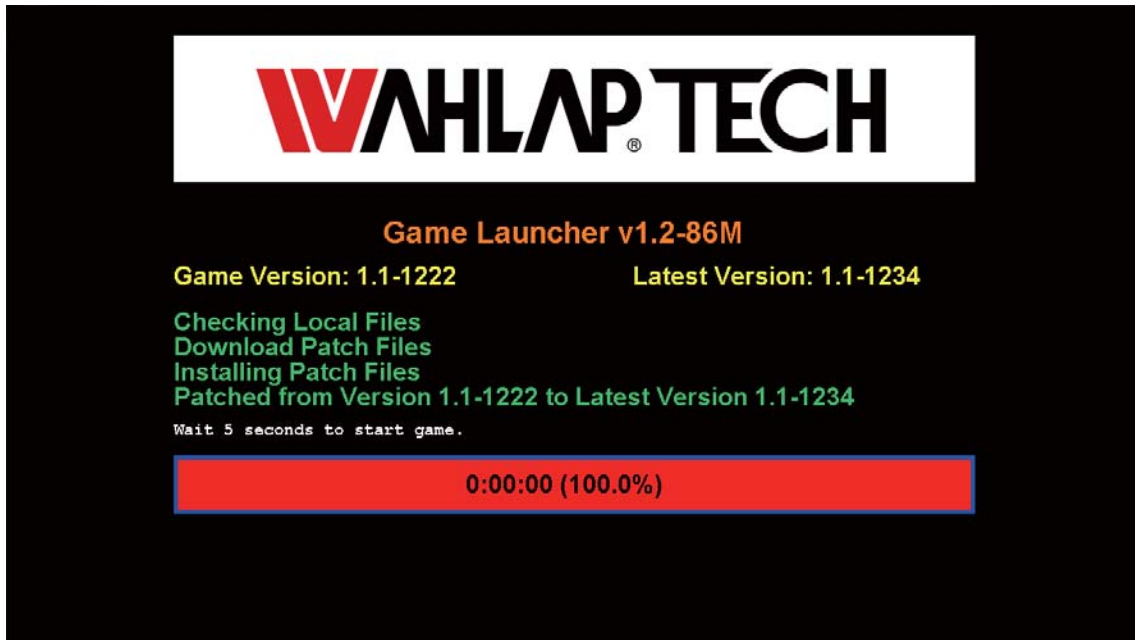

Case 3 – ERROR: Local Network Not Online

Under the below screen, the machine cannot connect to any network. The machine may have network cable problem. Please wait for 10 seconds to start game.



Case 4 – ERROR: Server Connection Failed

Under the below screen, the machine cannot connect to SRG patching server. The machine may have Internet accessing problem. Please wait for 10 seconds to start game.



4.4 USB Drive Patching Readme

Please be noticed:

- SRG USB Drive Patching version is set as v1.5.16-1866; a zip file has been created.
- The zip file is uploaded to http://www.stormracergame.com/patch/SRG_usb_1.5.16-1866_srgm.zip
- Besides launcher update, other patching files are same as v1.5.16-1866.
- The zip file includes all patching files from SRG v1.5.9 to v1.5.13, which are corresponded to any version from SRG v1.5.9 to v1.5.13.

4.4.1 How to Boot from USB for SRG USB Patching

In the BIOS setting, "Boot Other Devices" adds a system-determined list of devices to check for bootable software after the three user-configurable boot devices have been checked. Please boot from USB-HDD by setting this to Enabled, but only when the SATA interface is Disabled.

Options that BIOS provides for First, Second, Third Boot Device do not include an option for USB-HDD:

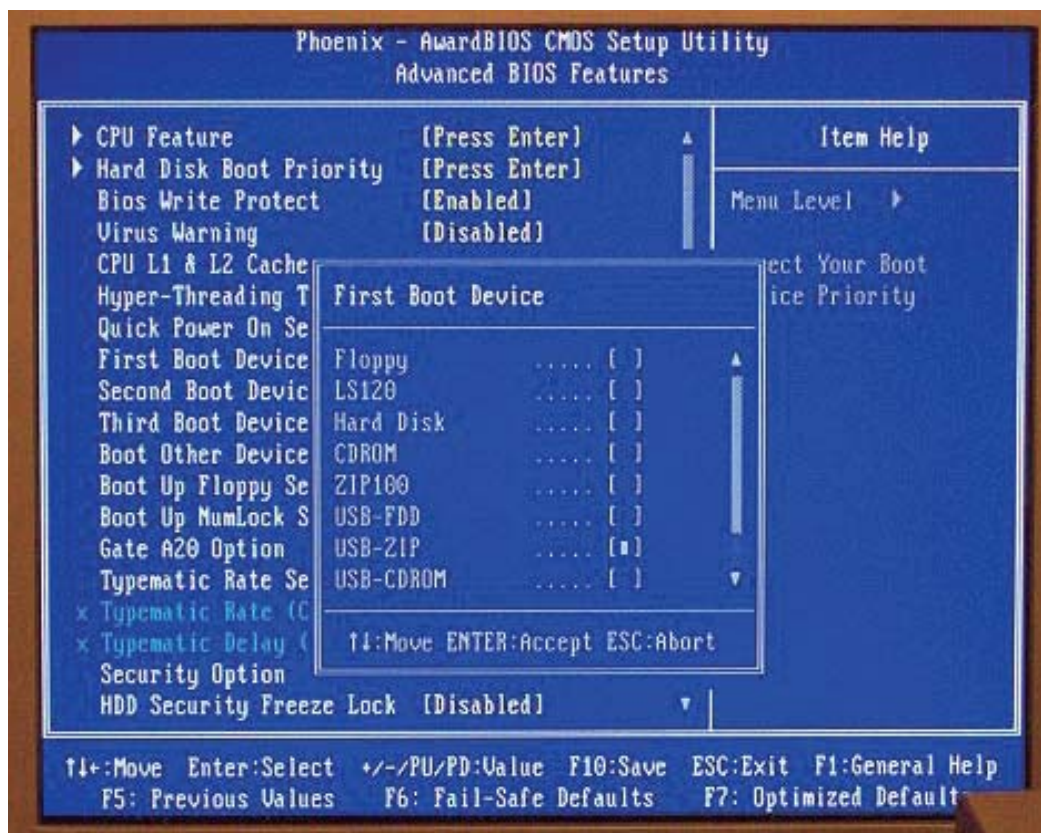

Below screen shows “Hard Disk Boot Priority” of the BIOS setting.

In the screen, all hard-disks listed that are detected by the BIOS, both SATA and USB. Order can be changed in which these hard-disks are searched for bootable software.

This screen shows how to boot from USB-HDD:



In addition to this, one of the Boot Devices is needed to be set to “Hard Disk” and/or set Boot Other Devices to “Enabled”.

4.4.2 For SRG version 1.5.12 or before

1. Download and extract SRG_usb_xxx.zip into a root directory of USB drive.

Name	Date modified	Type	Size
boot	8/20/2014 4:33 PM	File folder	
launcher	8/20/2014 4:12 PM	File folder	
screenshot	9/19/2014 3:07 AM	File folder	
SRG	8/20/2014 4:13 PM	File folder	
tce	8/20/2014 4:13 PM	File folder	
game_dev.txt	9/22/2014 9:25 PM	Text Document	1 KB
game_dir.txt	8/28/2014 6:57 PM	Text Document	1 KB
install_boot.bat	8/22/2014 2:20 PM	Windows Batch File	1 KB
launcher_dir.txt	9/22/2014 10:04 PM	Text Document	1 KB
syslinux.cfg	8/20/2014 4:41 PM	CFG File	1 KB
syslinux.exe	10/14/2013 2:11 A...	Application	235 KB

2. Run "install_boot.bat" once in USB drive.

3. Remove the USB drive from PC and insert into SRG machine.

4. Set BIOS to boot from USB drive in SRG machine.

5. Boot from USB drive and wait for installing new Launcher program.

The below screen shows when first boot is successful:

```
Booting Core 5.3
Running Linux Kernel 3.8.13-tingcore.
Checking boot options... Done.
Starting udev daemon for hotplug support... Done.
Scanning hard disk partitions to create /etc/fstab
Setting Language to C Done.
Possible swap partition(s) enabled.
Loading extensions... Done.
Setting keymap to us Done.
Restoring backup files from /mnt/sba1/tce/mydata.tgz Done.
*****
Updated to Latest Launcher in the Harddisk .

DO NOT reboot from USB drive now.
*****
Wait 20 seconds to reboot ...
```

6. After reboot, set BIOS back to boot from hard disk.

7. The new launcher will install the SRG patch from USB drive.

The below screen shows when USB Drive is found: (Game Launcher version: v1.2-94M)

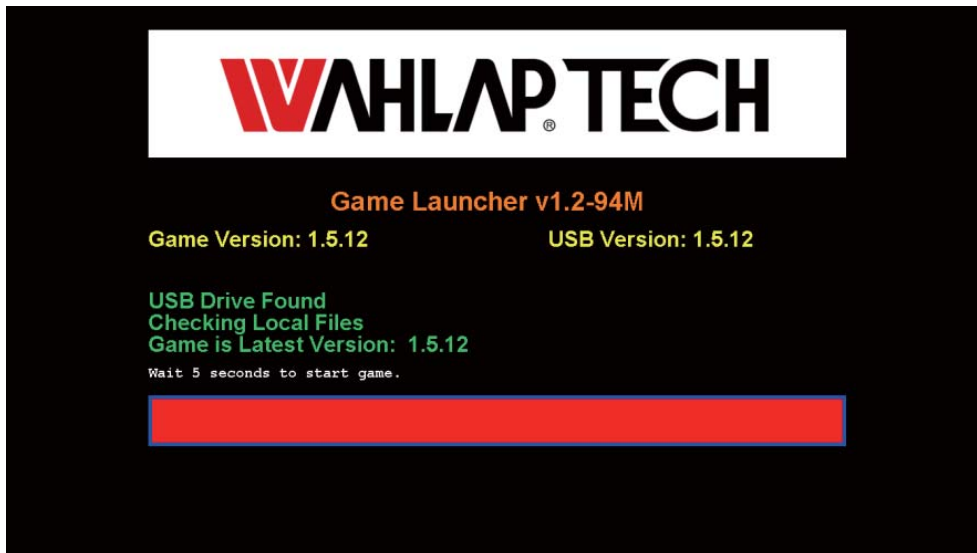

8. After SRG patching success, remove the USB drive.

The below screen shows when patching is successful:

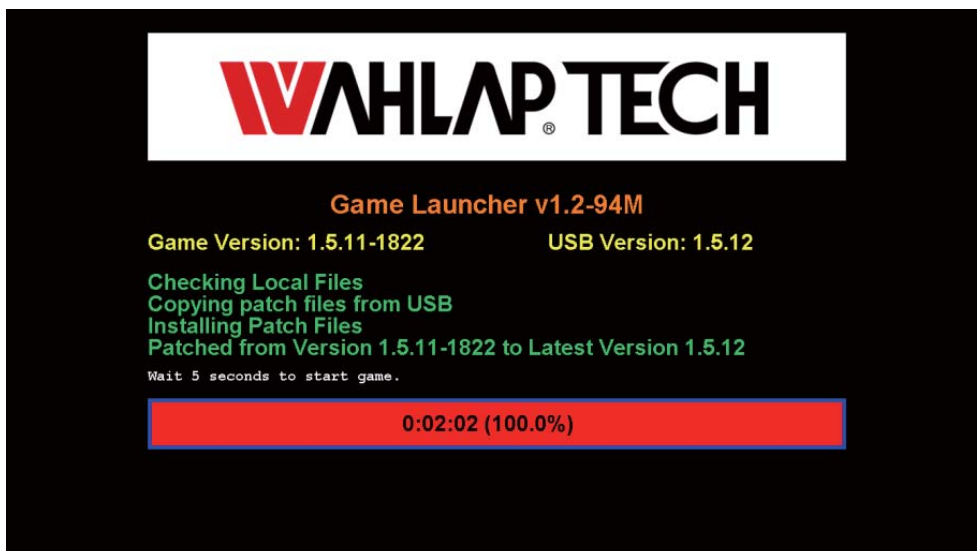

4.4.3 For SRG version 1.5.14 or after

1. Download and extract SRG_usb_xxx.zip into a root directory of USB drive.
2. Remove the USB drive from PC and insert into SRG machine.
3. Boot the SRG machine, the launcher will install the SRG patch from USB drive.
4. After SRG patching success, remove the USB drive.

4.4.4 For SRG versions Downgrading

If the launcher detects the SRG version of the USB patch version is lower than the current version, the below screen message will be shown. Please unplug the USB at once to STOP the downgrading, or it will proceed in 30 seconds.



WARNING: Unplug USB now if want to STOP degrading, or will proceed in 30 seconds.

4.4.5 Invalid Cases of USB Drive Patching

Case 1 – Invalid file CRC in USB

Under the below screen, one of the files in USB is invalid. Please re-install the patch file into USB drive. Please wait for 10 seconds to start game.



Case 2 – Missing file in USB

Under the below screen, one of the files in USB is missing. Please re-install the patch file into USB drive. Please wait for 10 seconds to start game.



Case 3 – Invalid USB drive, no CRC file list

Under the below screen, USB drive is invalid, no CRC file list is found. Please re-install the patch file into USB drive.

Please wait for 10 seconds to start game.



Case 4 – Invalid USB drive, no version file

Under the below screen, USB drive is invalid, no version file is found. Please re-install the patch file into USB drive.

Please wait for 10 seconds to start game.



Case 5 – Invalid USB drive, missing patch directory in USB

Under the below screen, USB drive is invalid, patch directory in USB is missing. Please re-install the patch file into USB drive.

Please wait for 10 seconds to start game.



4.5 Operator MENU

4.5.1 Arcade Operation Mode

1. Under the Demo screen, press the [Test] key of the coin control box to enter the [Arcade Operator], the main menu is shown below.



2. Enter the menu screen, use the arrow keys to select a menu item, press the [Test] key to enter the sub-menu, follow the screen prompt message at the bottom-right side.
3. After the setup is completed, select [Save] in the main menu, then press the [START] button or press the [services] to exit the user interface.



4.5.2 Languages

You can select the operating language in [Language].

1. Enter the [Arcade Operator] > [Language], use the left and right arrow keys to switch to the desired language.



4.5.3 Master Volume

In [Master Volume], you can set the outputs of the volume of sounds by the arcade machine.

1. Enter the [Arcade Operator] > [Master Volume], the inputs of the volume are set between 0-1.

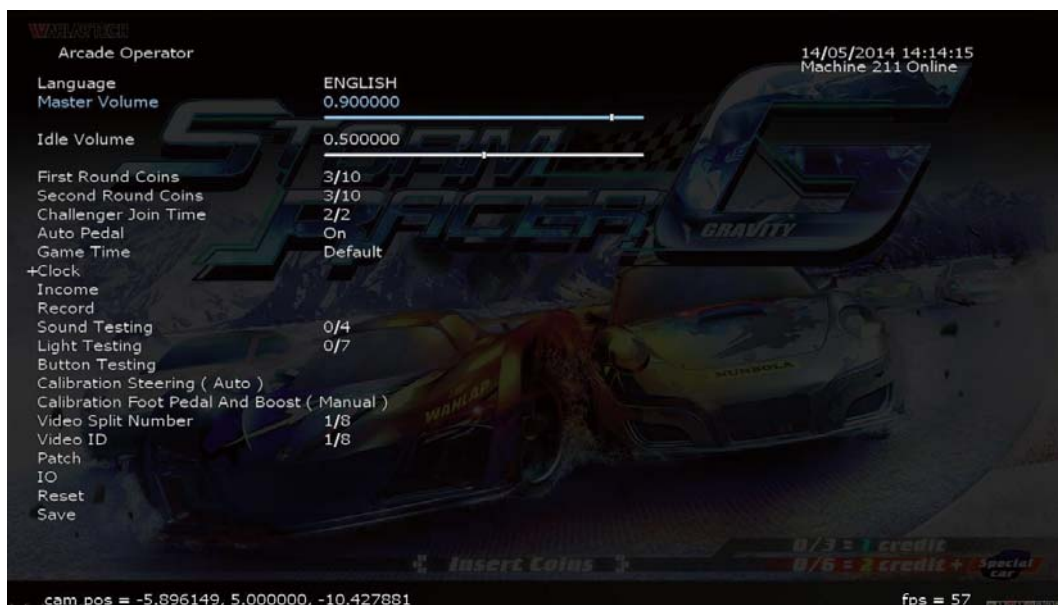

4.5.4 Idle Volume

In [Idle Volume], you can set the outputs of the volume of sounds by the arcade machine.

1. Enter the [Arcade Operator] > [Idle Volume], the inputs of the volume are set between 0-1.



4.5.5 “Clear Coins” function

1. Service Key to open AO Menu
2. In the below operator menu, “Clear Coins” item is showed.

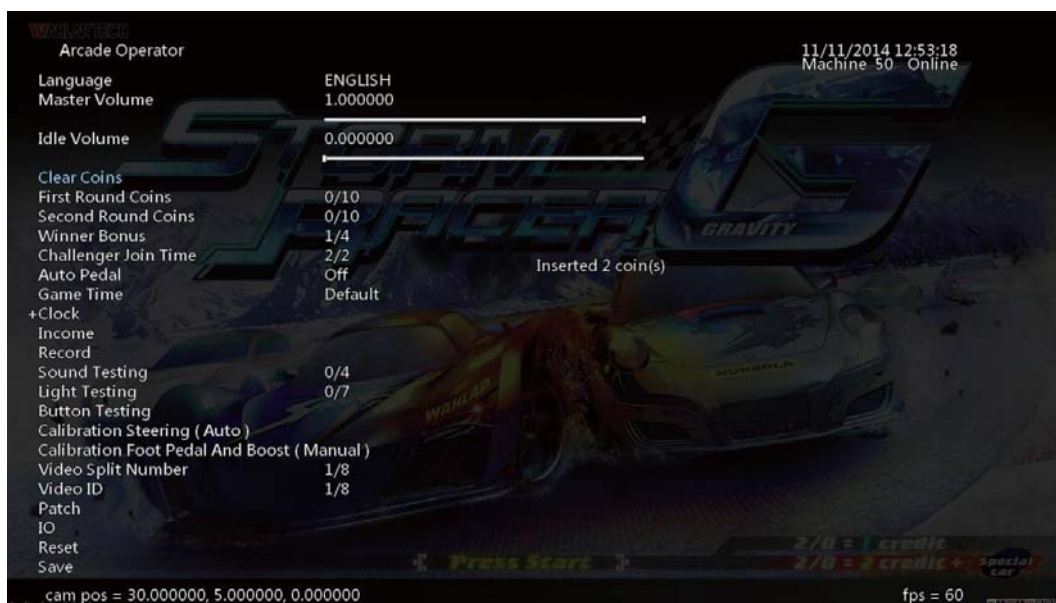

3. Press Service Key to confirm “Clear Coins” action.

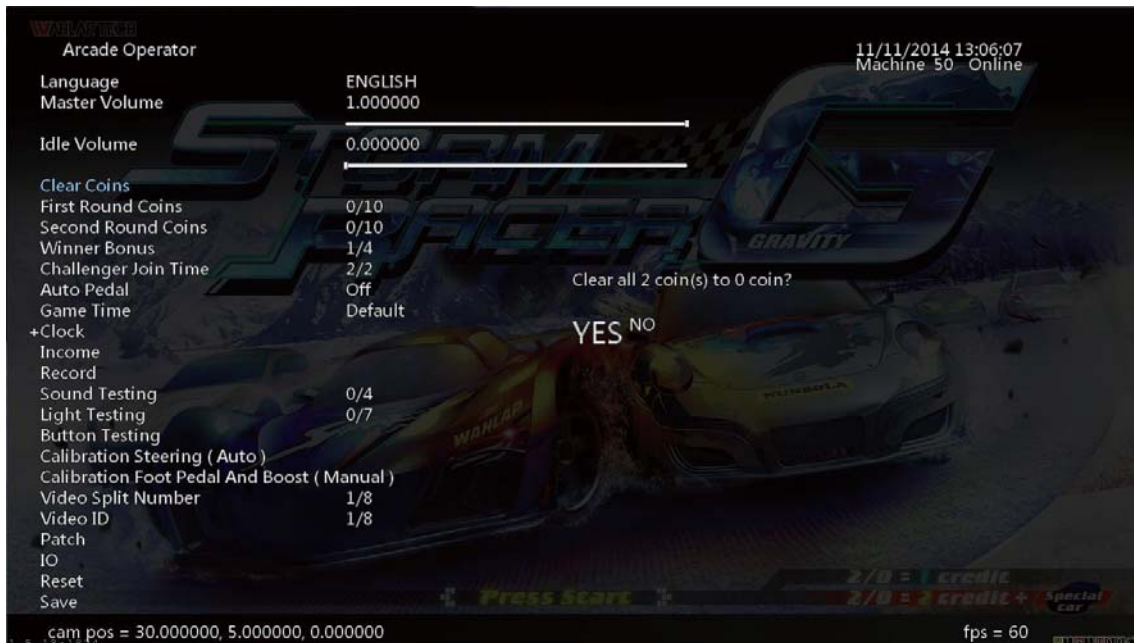

4.5.6 First Round Coins

In [First Round Coins], you can set the number of coins per game need to invest per race.

1. Enter the [Arcade Operator] > [First Round Coins], the inputs of the number of coins inserted set between 0-10.



4.5.7 Second Round Coins

In [Second Round Coins], you can set the number of coins per game need to invest per race.

1. Enter the [Arcade Operator] > [Second Round Coins], the inputs of the number of coins inserted set between 0-10.



4.5.8 Winner Bonus

In [Winner Bonus], you can set several options for Winner Bonus setting .

1. Enter the [Arcade Operator] > [Winner Bonus], bonus can be set from None, 1st, 1st & 2nd and 1st & 2nd & 3rd.



This setting is available from English version 1.5.14-1836.

4.5.9 Challenger Join Time

In [Challenger Join Time], you can choose whether to allow challenger to join the race or not within 15 or 30 seconds after the race is started.

1. Enter the [Arcade Operator] > [Challenger Join Time], choose “15 seconds” or “30 seconds” to enable challengers to join race and “Disable” to turn it off.



Can be set as: Enable 15 seconds OR 30 seconds

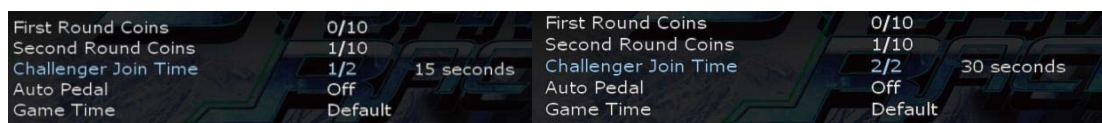

4.5.10 Auto Pedal

In [Auto Pedal], you can choose whether to turn on the auto pedal or not.

1. Enter the [Arcade Operator] > [Auto Pedal], choose “Yes” to enable auto pedal and “No” to turn it off.



4.5.11 Game Time

In [Game Time], you can choose whether to set the length of the game time.

1. Enter the [Arcade Operator] > [Game Time], choose “Short” to enable a shorter game time and “Long” to enable a longer game time.



4.5.12 Clock

In [Clock], you can set the system time.

1. Enter the [Arcade Operator] > [Clock].



Use the arrow keys to select [Clock], and then press the [START] button to expand the options of time setting.

2. Use the arrow keys to select the item you want to set, and then use the left and right arrow keys to switch the setting value, after the setup is complete, select [Settings] save [Clock] is set.

3. After the setup is saved, select [Clock] again to hide the setting projects, and continue to operate.

4.5.13 Income

In the page [Income], you can go through the revenue-related information of the machine.

1. Enter the [Arcade Operator] > [Income], selection screen is as follows:



- [Records] records all tournament games which have been completed.
 - Left Hand Side: Vehicle models: the frequency of use
 - Right Hand Side: Tracks Name: the frequency of selection

4.5.14 Record

In the page [Record], you can set the machine's operating system settings.

1. Enter the [Arcade Operator] > [Record], selection screen is as follows:

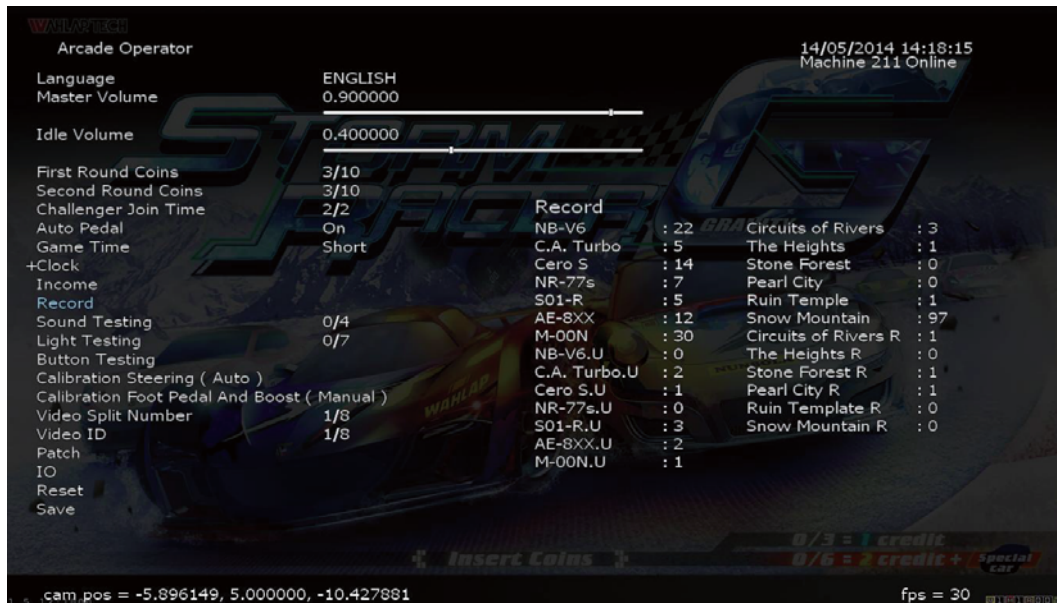

- [Records] records all tournament games which have been completed.
- Left Hand Side: Vehicle models: the frequency of use
- Right Hand Side: Tracks Name: the frequency of selection

4.5.15 Sound Testing

In the page [Sound Testing], you can set the machine's operating system settings.

1. Enter the [Arcade Operator] > [Sound Testing], selection screen is as follows:

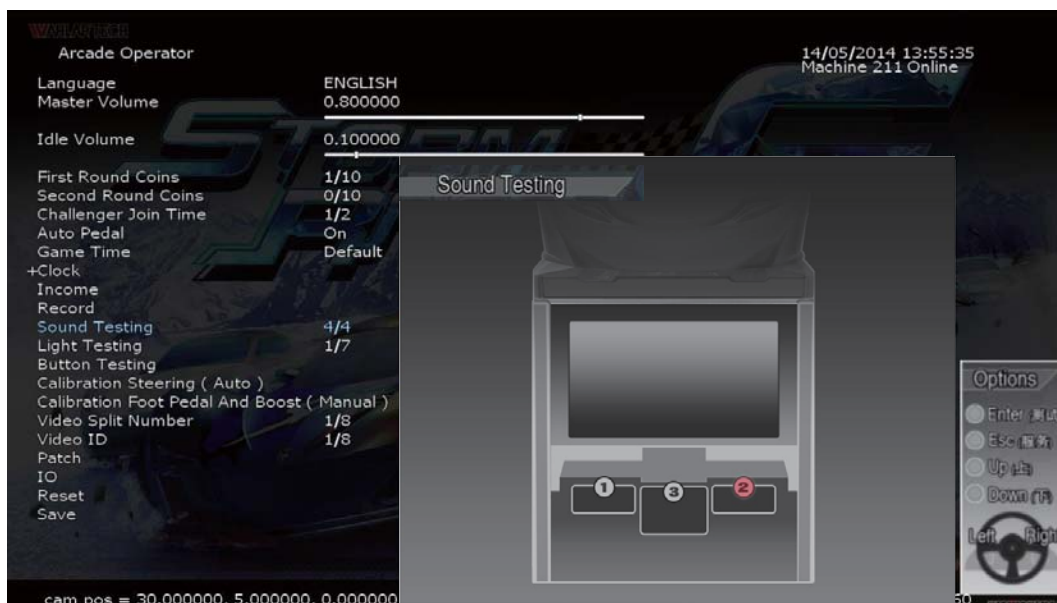

2. In [Sound Testing], use the left and right arrow keys to select the item you want to test, selected speakers (RED light) will play the test automatically and continuously.

- Normal Playback: Use the left and right arrow keys to select the set of speakers (1 to 6) you want to test with.
- If there is no sound, check whether the volume buttons are set at the minimum level, if there is still no sound, please operate the speaker troubleshooting.

4.5.16 Light Testing

In the page [Light Testing], you can test if each set of lights (1 to 7) is in normal condition.

1. Enter the [Arcade Operator] > [Light Testing], selection screen is as follows:

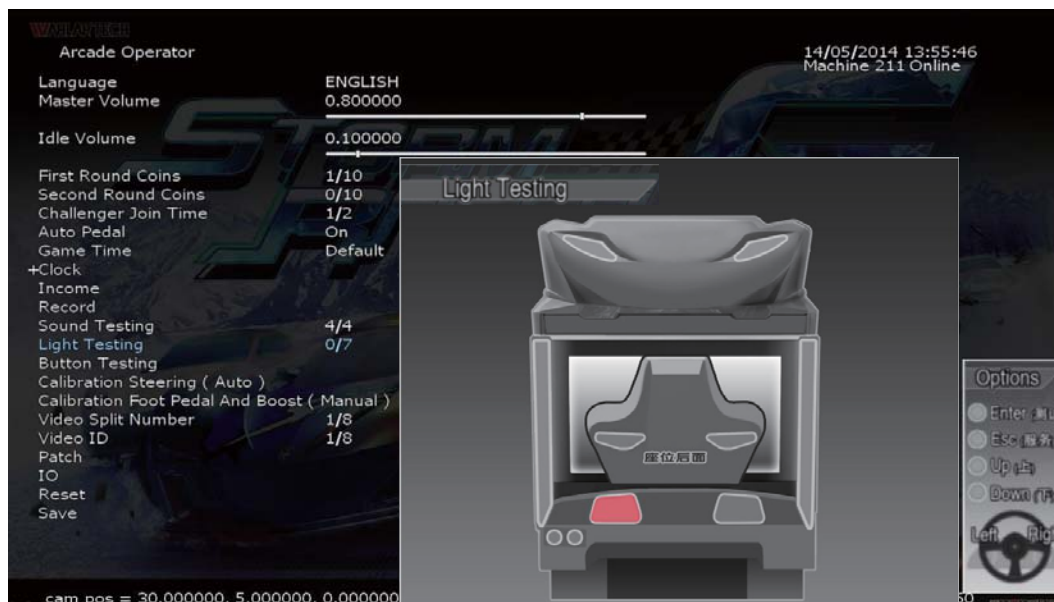

2. In [Light Testing], use the left and right arrow keys to select the item you want to test.

- This test can operate a total of eight options, from 0-7.
- The selected item (RED light) will automatically light for testing.

4.5.17 Button Testing

In the page [Button Testing], you can test if buttons are in normal condition.

1. Enter the [Arcade Operator] > [Button Testing], selection screen is as follows:

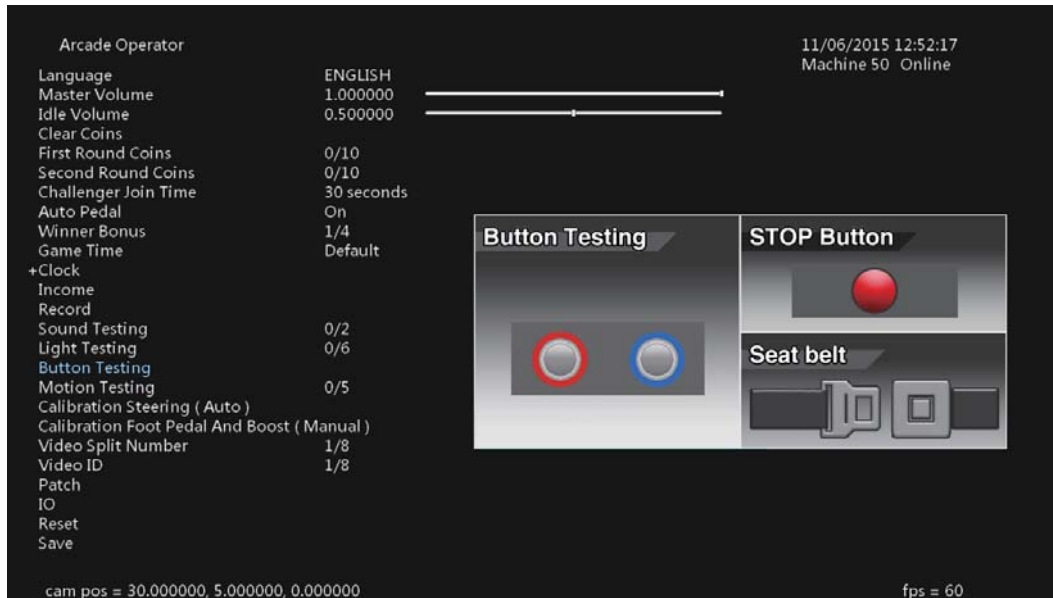

2. In [Button Testing], use the left and right arrow keys to select the item you want to test.

This test has a total of four options.

- [START] button y function
- [VIEW] button function
- Accelerator handle - Push function
- Accelerator handle - Pull function.

3. Press the button which is needed to be tested, the button displayed on the screen will light up in RED for normal condition.

4.5.18 Calibration Steering (Auto)

In the page [Calibration Steering (Auto)], you can test and proofread the sensitivity of the steering wheel and handling.

1. Enter the [Arcade Operator] > [Calibration Steering (Auto)], selection screen is as follows:

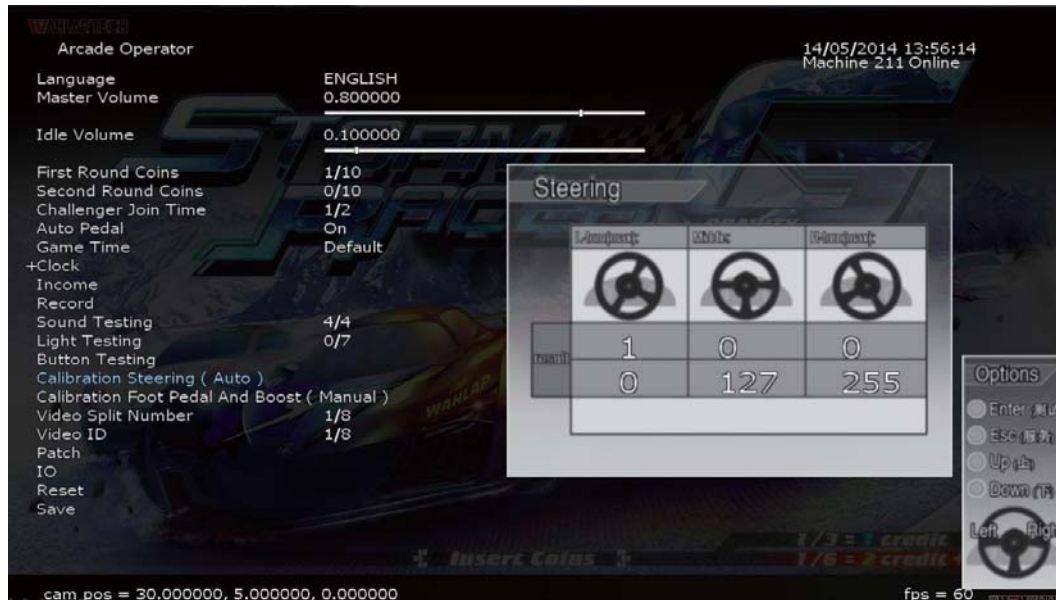

2. In [Calibration Steering (Auto)], the steering wheel will calibrate automatically to show the test value.

- This calibration project is divided into three categories:
 - Left in Most-Valued: Left-turn torque of the steering wheel
 - Center: the steering wheel in the median position;
 - Right in Most-Valued: Right-turn torque of the steering wheel

3. When turning the steering wheel, numerical changes with the rotation rate. When turning to the Most-Right, the indicated value is about 255; 0 when turning to the Most-Left.

4. The value of the steering wheel is displayed in the Calibration Result column. The First column is the Actual-calibrated value; the Second column is the Ideal-calibration value.

5. The calibration value must be in the range of 5% of the ideal value, or criticized as sub-standard.

6. The lowest column will be displaying the Rating Symbol: “✓” tick as qualified; "X" cross as sub-standard, adjustment is required.

4.5.19 Calibration Foot Pedal and Boost (Manual)

In the page [Calibration Foot Pedal (Manual)], you can test and proofread the sensitivity of the foot pedal.

1. Enter the [Arcade Operator] > [Calibration Foot Pedal (Manual)], selection screen is as follows:

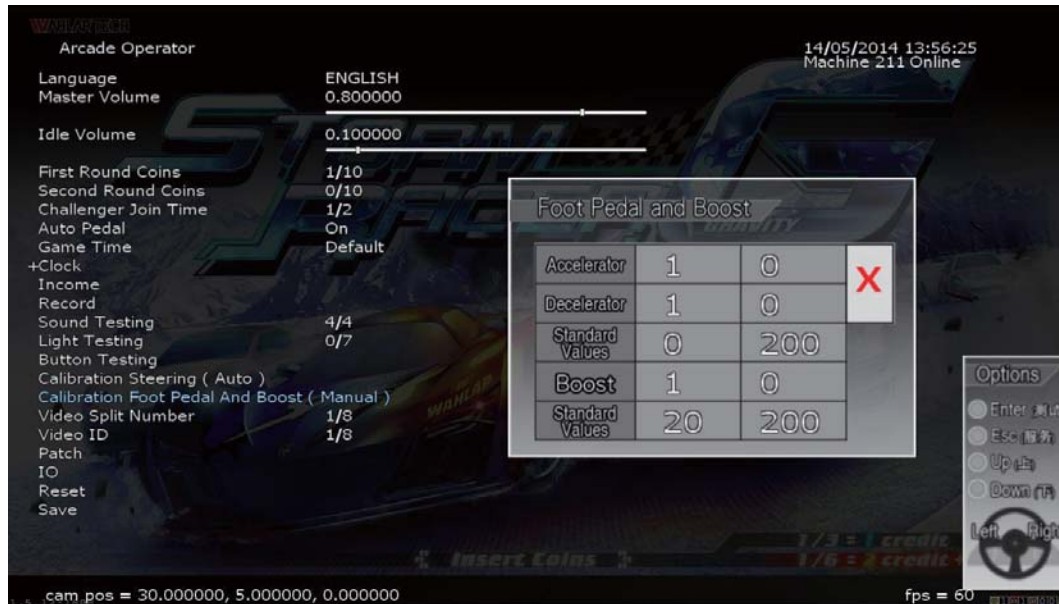

2. There are two projects in this calibration operation:
 - Throttle: By stepping the throttle, the value will be changed. By stepping the throttle to the most, the value should be around 255; If the throttle is not be stepped, the value should be around 0.
 - Brake: By stepping the brake, the value will be changed. By stepping the brake to the most, the value should be around 255; If the throttle is not be stepped, the value should be around 0.
3. The maximum and minimum values of the throttle and brake should be within 10% of the ideal value.

The lowest column will be displaying the Rating Symbol:

“✓” tick as qualified; "X" cross as sub-standard, adjustment is required.

4.5.20 Video Split Number

In the page [Video Split Number], you can choose how many machines you want to split the video as display.

1. Enter the [Arcade Operator] > [Video Split Number], selection from 1 to 8 machines.



2. There are three displays in this operation:

- Machine: The machine number.
- Video: The sequence of video in the machine.
- Network: The network status: On or Off

4.5.21 Video ID

In the page [Video ID], you can set the video ID of the machine.

1. Enter the [Arcade Operator] > [Video ID], selection from 1 to 8 machines.

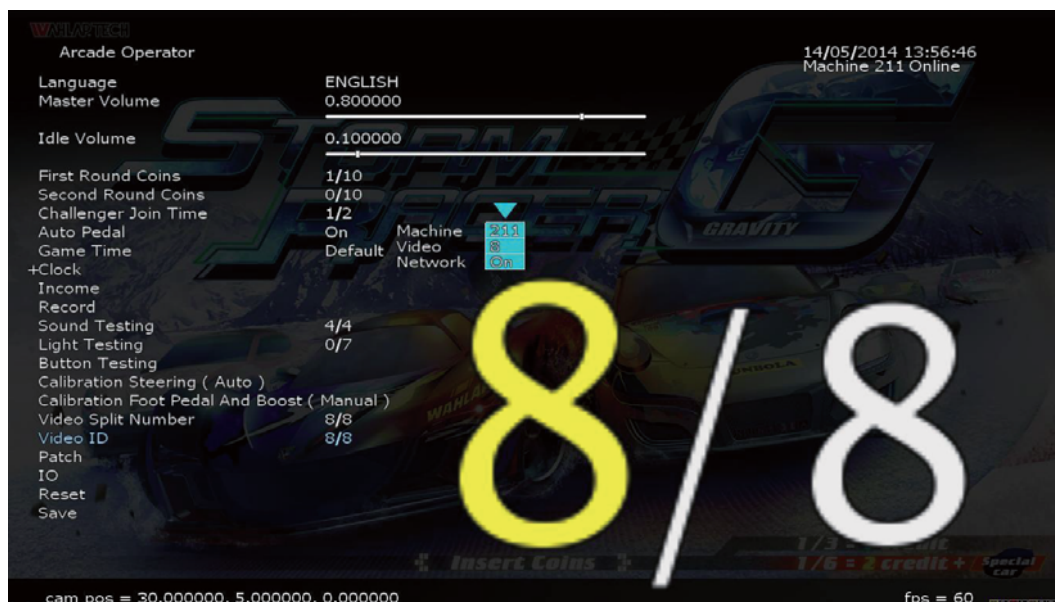

2. There are three displays in this operation:

- Machine: The machine number.
- Video: The sequence of video in the machine.
- Network: The network status: On or Off

4.5.22 Patch

In the page [Patch], you can do the patching.

1. Enter the [Arcade Operator] > [Patch], selection screen is as follows:

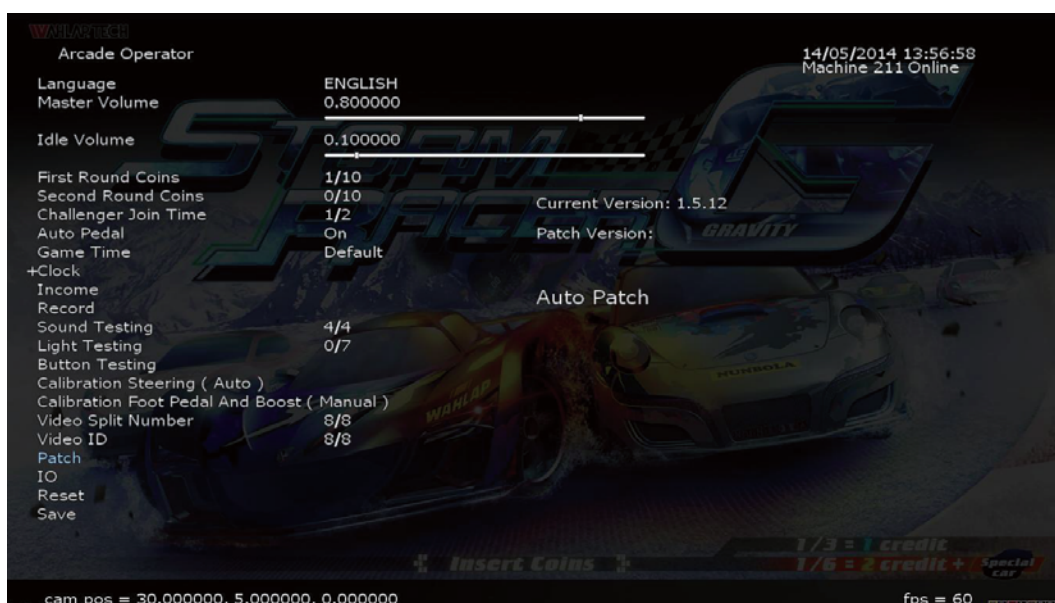

4.5.23 IO

In the page [IO], you can check if there is any IO device.

1. Enter the [Arcade Operator] > [IO], selection screen is as follows:

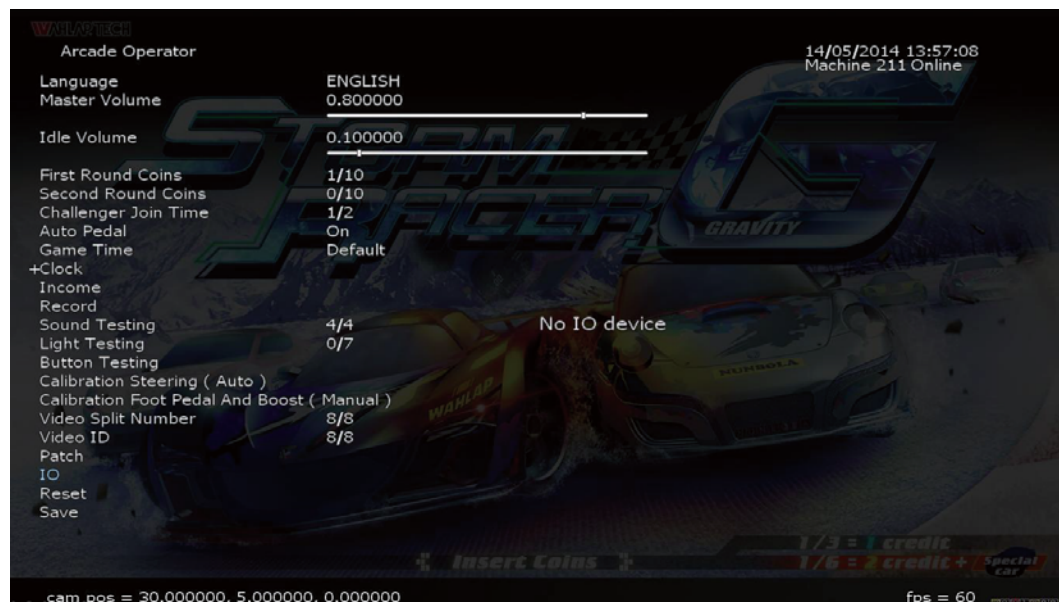

4.5.24 Reset

In the page [Reset], you can set up to restore all settings to the original settings.

1. Enter the [Arcade Operator] > [Reset], selection screen is as follows:



2. Select [Reset] and then press the [START] button in the arcade. All settings will be restored to default, all arcade records will be cleared.

4.5.25 Save

In the page [Save], you can save all the settings in the setup.

1. Enter the [Arcade Operator] > [Save], selection screen is as follows:

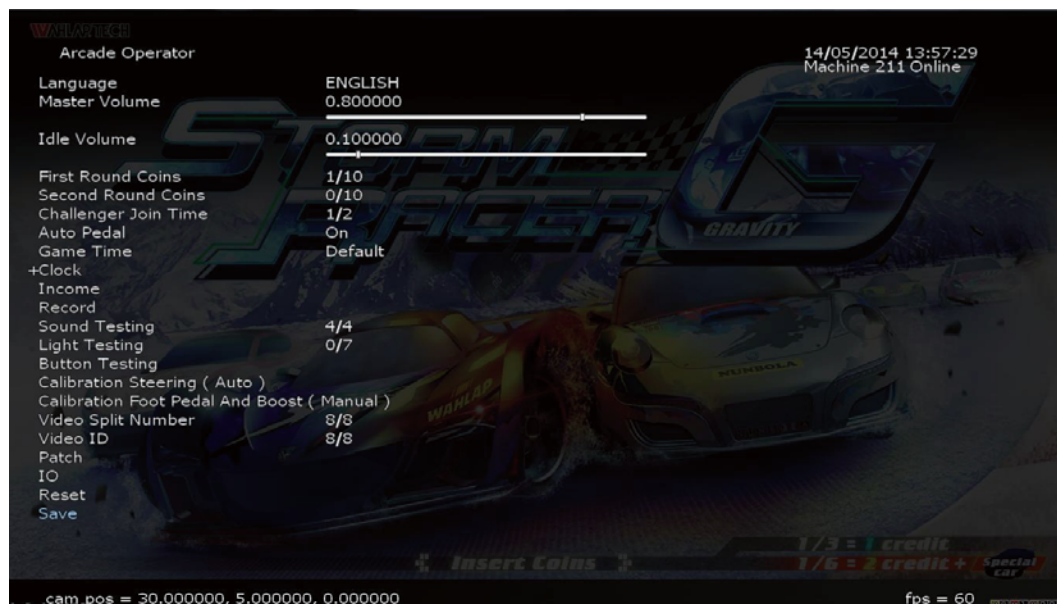

2. Select [Save] and then press the [START] button, all settings will be saved.

4.5.26 Game-Play Screen Information

In the below of the [Game-Play screen], information about the game and machine is shown at bottom.



1. Bottom Left-corner



- Main Version: 1.5.14
- Build Version: 1842

2. Bottom Right-corner

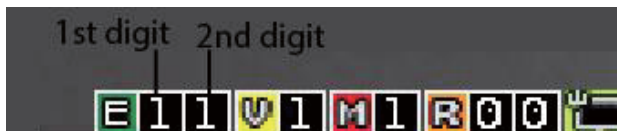

- E – IO Connection Error
No. on the left – IO Error Code (1 represents Error of Writing IO API; 2 represents Error of Reading IO API) No. on the right: IO Error Count (no. will be added by 1 when new error occurs, excluding for repeated of same error)
- V – Video ID: 1
- M – No. of machines connected LAN: 1
- R : (for development purpose)

5. Maintenance and Service

5.1 Maintenance and service

Even though the machine works normally for a long time, the fault will occur. Therefore, please perform routine check and maintenance concerning the following to ensure a long-term use.

■ External Inspection

- Stick “Warning” stickers correctly, keep it legible.
- Firmly tighten the bolt for each adjuster.
- Tighten screws for speaker assembly.
- Tighten the signboard firmly.
- Check if the screws fixing the parts loose.
- Check if the connectors loose or missing.

■ Operation Inspection (With power on)

- Sound is normally emitted from the speakers or not.
- Fluorescent lamps and LED and button lamps light up or not
- Coin acceptor works properly or not.
- Lifting and falling devices work properly or not.
- YZ sensor works properly or not.

After completing all the checks, operate the game again and check the above items with full care!

■ Servicing (conducted by a technician only)

- Cut off the main power supply to avoid injury or electric shock when performing maintenance.
- Please contact our service center when performing any work that is not specified in this Manual, and follow the instruction provided by the service center.
- For consumables and spare parts (including screws), please use products specified by Wahlap Technology.
- Even though the main power is cut off, there is still high temperature and high pressure in the power board and the monitor. The person will be burnt or get an electric shock if he touches such parts. Please pay full attention to avoid contact.
- Be sure to cut off the main power when you alter a spare part or unplug a connector.

5.2 Part Replacement

5.2.1 Replacement of camera

1. Remove 4 screws to fix the camera components and take out the camera components.
2. Replace the camera or camera lamp-panel.
3. After completion, reinstall it in a reverse order.

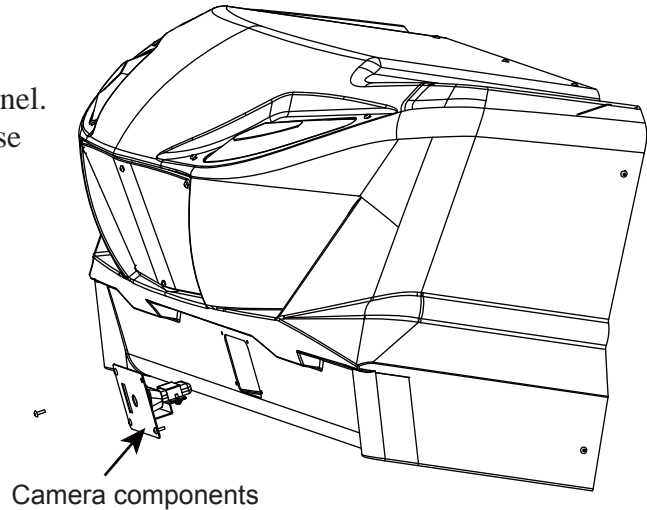

5.2.2 Replacement of light-box soft lamp

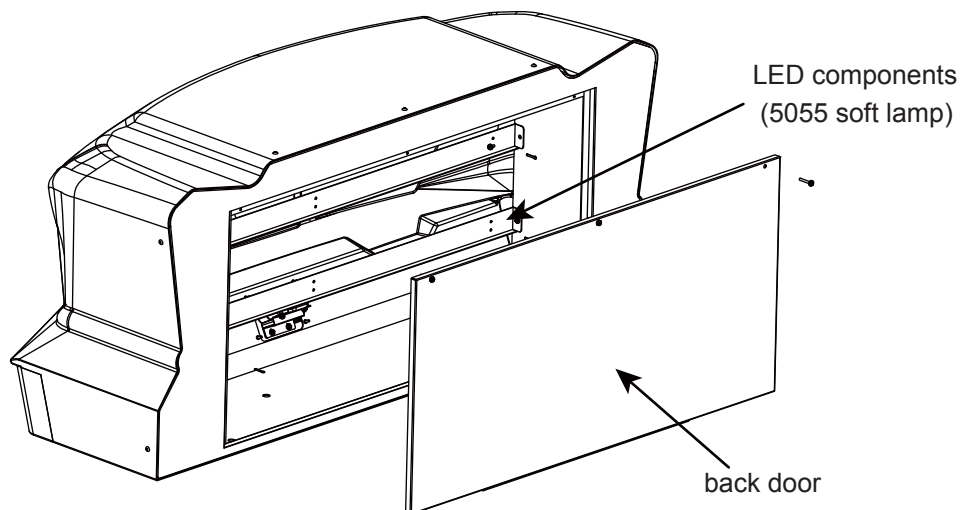

1. Remove the light-box back-door.
2. Take out the light-box LED components and replace the soft lamp.
3. After completion, reinstall it in a reverse order.

5.2.3 Replacement of button components

1. Remove the screws and take out START-button components.
Replace START button or viewpoint switching button according to the diagram.

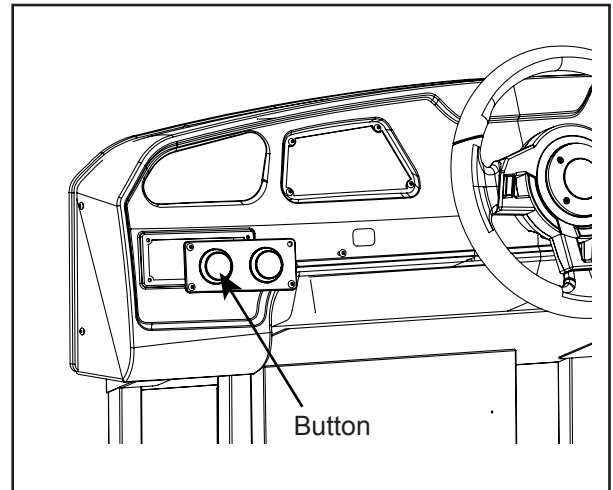

2. Replacement of button

- A. Turn LED gently first and take out LED.
- B. Turn the button according to the arrow and replace it.

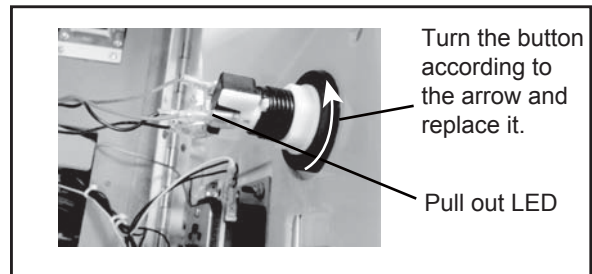

3. Replacement of the button LED:

- A. Turn LED gently first and take out LED.
- B. Pull out LED according to the diagram and replace LED.

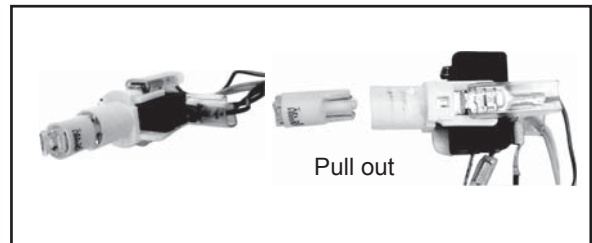

4. After completion, reinstall it in a reverse order.

5.2.4 Replacement of accelerating-handle components

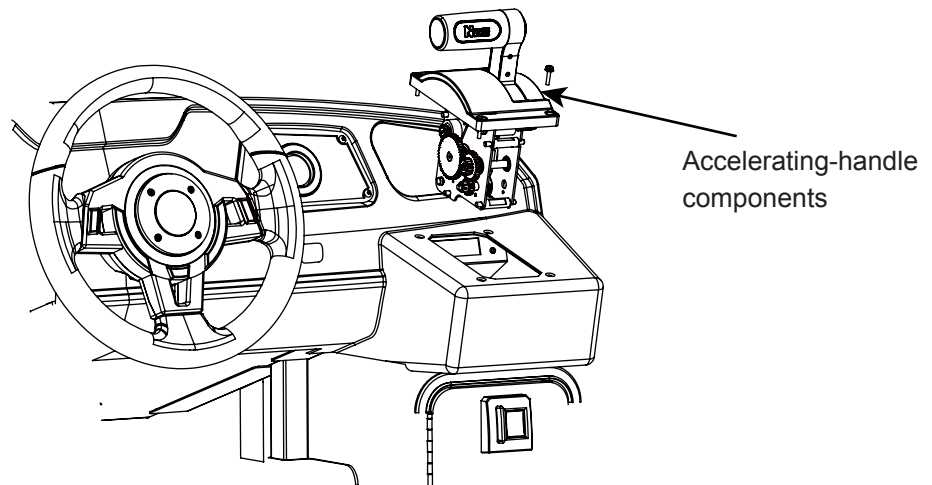

- 1.Remove the screws and remove the accelerating-handle components.
- 2.Replace the accelerating-handle components.
- 3.After completion, reinstall it in a reverse order.

5.2.5 Replacement of the pedal components

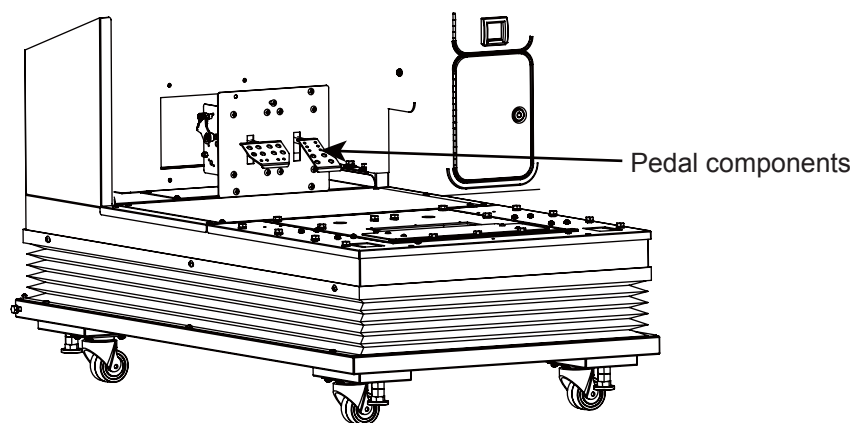

- 1.Remove the screws and remove the pedal components.
2. Replace the pedal components.
3. After completion, reinstall it in a reverse order.

5.2.6 Replacement of coin acceptor

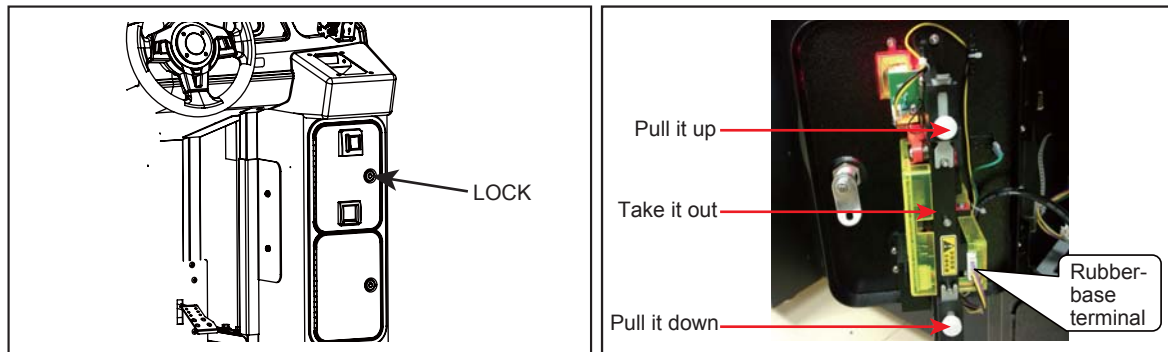

1. Open the door lock of coin acceptor.
2. Pull out the rubber-base terminal, and then replace the coin acceptor according to the diagram. After completion, reinstall it in a reverse order.

6. Assembly

6.1 Assembly tree diagram

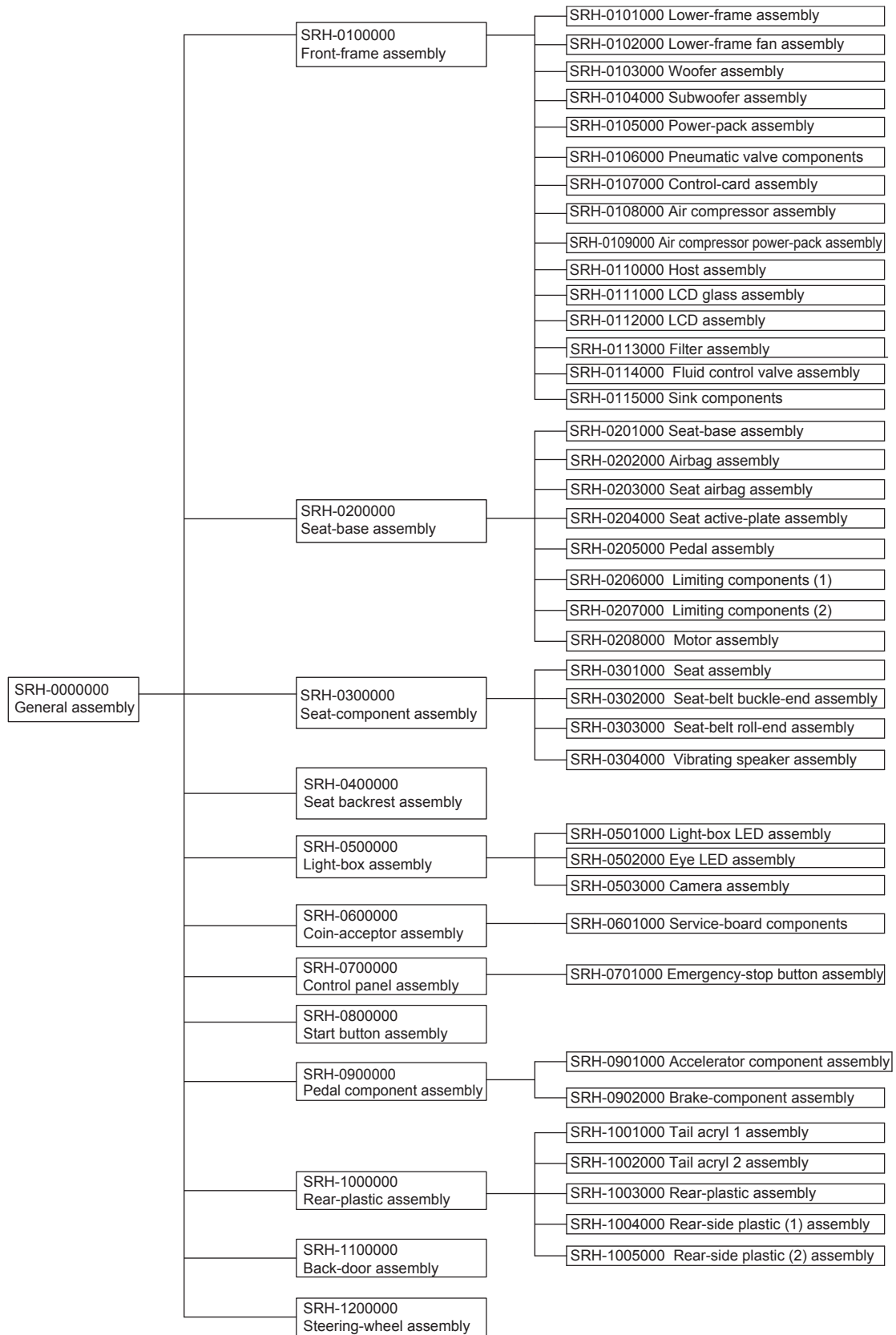

6.2 General assembly(1)

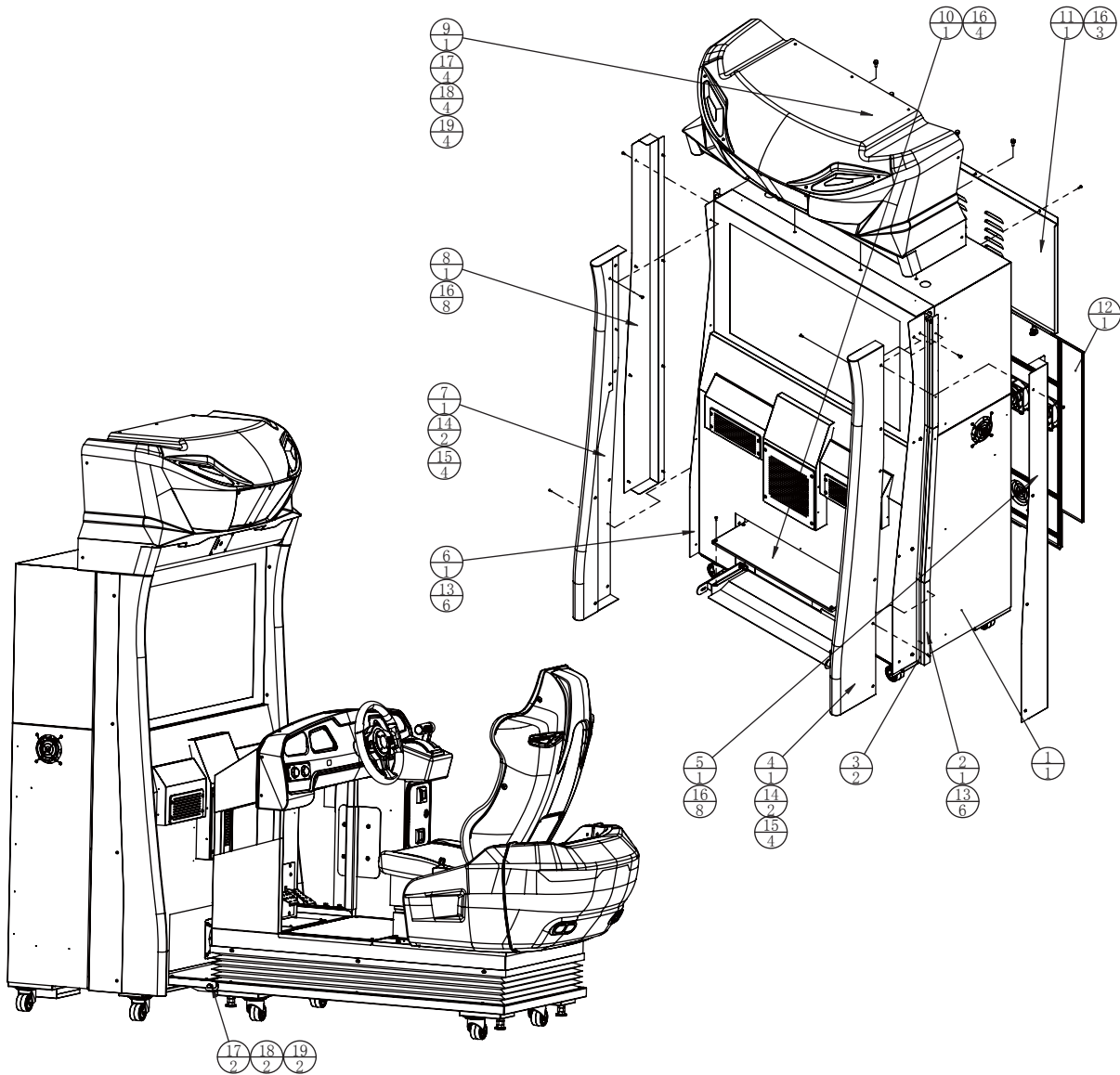

10	SRH-0000A12	Connecting iron cover plate	SPCC-1.5T	1	1.1.WA16C00110								
9	SRH-0500000	Light-box assembly		1		19		External hex socket screw	M8*20(Black)	10	1.6.LSM82011		
8	SRH-0000A04	Left side plastic fixed iron 1	SPCC-1.2T	1	1.1.WA16C00040	18		Spring washer	M8 (Black)	14	1.6.DP208011		
7	SRD-0000C02	Side lamp cover - left	ABS-2.0T	1	1.8.WA16A020	17		Flat washer	φ8*φ16*2.0(Black)	14	1.6.DP108011		
6	SRH-0000A03	Left side plastic fixed iron 2	SPCC-1.2T	1	1.1.WA16C00030	16		Cross recessed flat head screw	M5*12(Black)	30	1.6.LS251021		
5	SRH-0000A02	Right side plastic fixed iron 1	SPCC-1.2T	1	1.1.WA16C00020	15		Cross recessed flat head screw	M5*12(chrome)	8	1.6.LS251022		
4	SRD-0000C01	Side lamp cover - right	PMMA- 2.0T	1	1.8.WA16A010	14		Cross recessed countersunk head screw	M4*12(chrome)	4	1.6.LS41022		
3		5050 soft LED lamp panel of screen right and left	DC12V RGB60	2	1.4.ZM9E0920	13		Cross recessed fillister head three-combination screw	M5*12(Black)	30	1.6.LS851021		
2	SRH-0000A01	Right side plastic fixed iron 2	SPCC-1.2T	1	1.1.WA16C00010	12	SRH-1100000	Back-door assembly				1	
1	SRH-0100000	Front-frame assembly		1		11	SRH-0000A13	Screen back door	SPCC-1.5T	1	1.1.WA16C00120		
No.	Draw No.	Name	Material/Spec.	Qty.	Product Code	No.	Draw No.	Name	Material/Spec.	Qty.	Product Code		

General assembly(2)

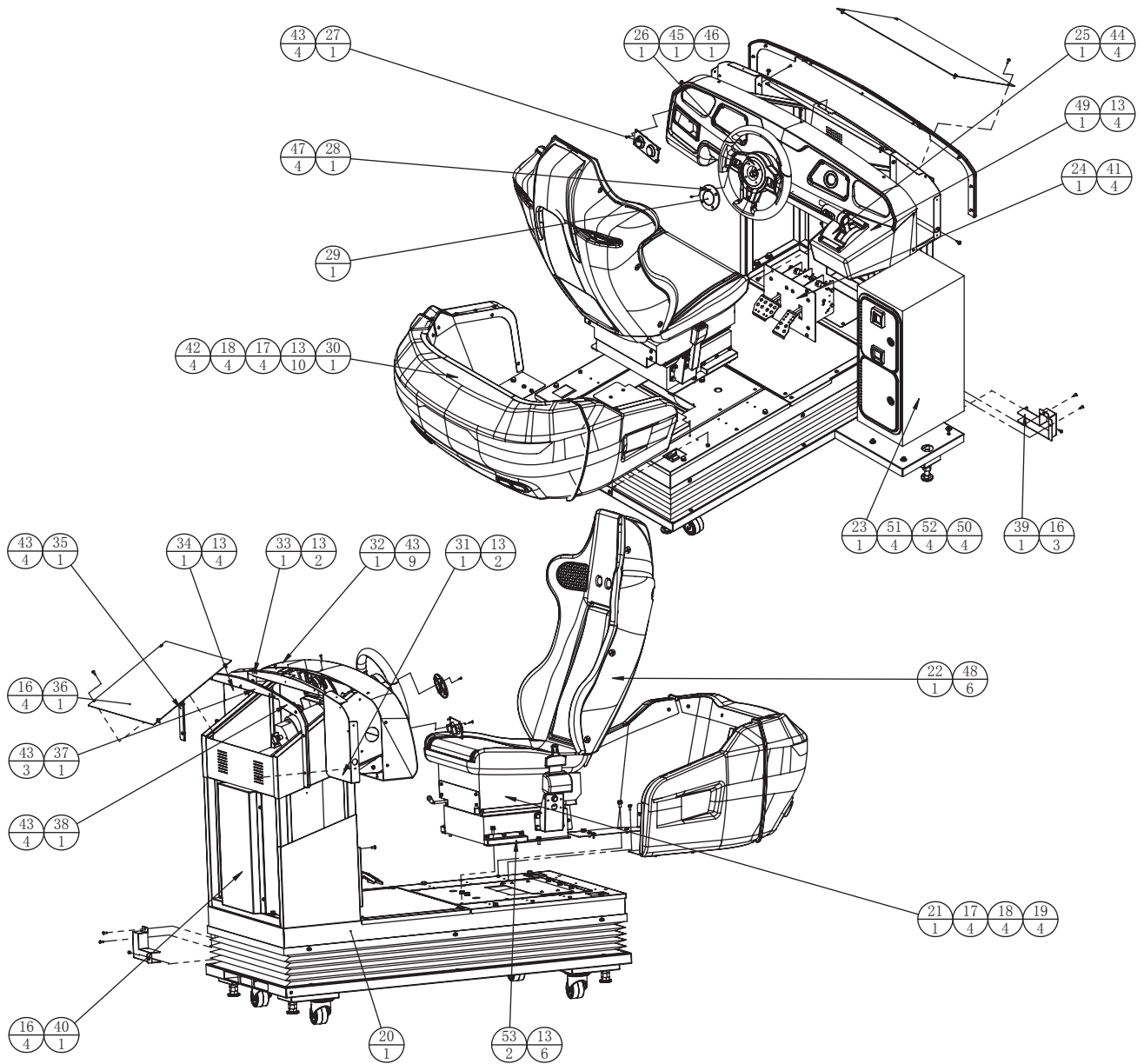

36	SRH-000A11	Motor cover plate	SPCC-1.5T	1	1.1.WA16C00100	53	SRH-000A14	Seat protection iron	SPCC-1.5T	2	1.1.WA16C00860
35	SRH-000D01	Console back PMMA1	PMMA-10.0T	1	1.7.WA16C00010	52		Hex head Cap Screw	M6 (color)	4	1.6.LM206013
34	SRH-000A07	Control panel fixed iron 3	SPCC-1.5T	1	1.1.WA16C00060	51		Plain washers	Φ6*20*2.0 (black)	4	1.6.DP106061
33	SRH-000A08	Control panel fixed iron 1	SPCC-1.5T	1	1.1.WA16C00070	50		Spring washer	M6 (black)	4	1.6.DP206011
32	SRH-0700000	Control panel assembly		1		49	SRH-000A05	Push rod fixed iron	SPCC-1.5T	1	1.1.WA16C00840
31	SRH-000A06	Control panel fixed iron 2	SPCC-1.5T	1	1.1.WA16C00050	48		Plastic screw		6	1.6.LS782050
30	SRH-1000000	Rear-plastic assembly		1		47		Hex socket fillister head screw	M3*8 (chrome)	4	1.6.LSF30012
29	SRH-P0004	Steering wheel acrylic	PMMA-3.0T	1	1.7.WA16C00150	46		Hexagon nut	M12 (Black)	1	1.6.LM112011
28	SRF-000C02	Steering wheel decorate plastic	ABS	1	1.8.WA10E020	45		Spring washer	M12 (Black)	1	1.6.DP212011
27	SRH-0800000	Start button assembly		1		44		Cross recessed fillister head three-combination screw	M6*16 (Black)	4	1.6.LS141022
26	SRH-1200000	Steering-wheel assembly		1		43		Hex socket flat head screw	M4*12 (chrome)	24	1.6.LS861031
25	SRF-1000000	Shift lever components		1	2.1.WA10E010	42		External hex socket screw	M8*16 (Black)	4	1.6.LS861021
24	SRH-0900000	Pedal component assembly		1		41		Cross recessed flat head screw	M6*12 (Black)	4	1.6.LS261021
23	SRH-0600000	Coin-acceptor assembly		1		40	SRH-000A09	Pedal cover plate	SPCC-1.5T	1	1.1.WA16C00080
22	SRH-0400000	Seat backrest assembly		1		39	SRH-000A10	Wire cover plate	SPCC-1.2T	1	1.1.WA16C00090
21	SRH-0300000	Seat-component assembly		1		38	SRH-000D03	Console back PMMA3	PMMA-10.0T	1	1.7.WA16C00030
20	SRH-0200000	Seat-base assembly		1		37	SRH-000D02	Console back MMA2	PMMA-10.0T	1	1.7.WA16C00020
No.	Draw No.	Name	Material/Spec.	Qty.	Product Code	No.	Draw No.	Name	Material/Spec.	Qty.	Product Code

6.3 Front-frame assembly

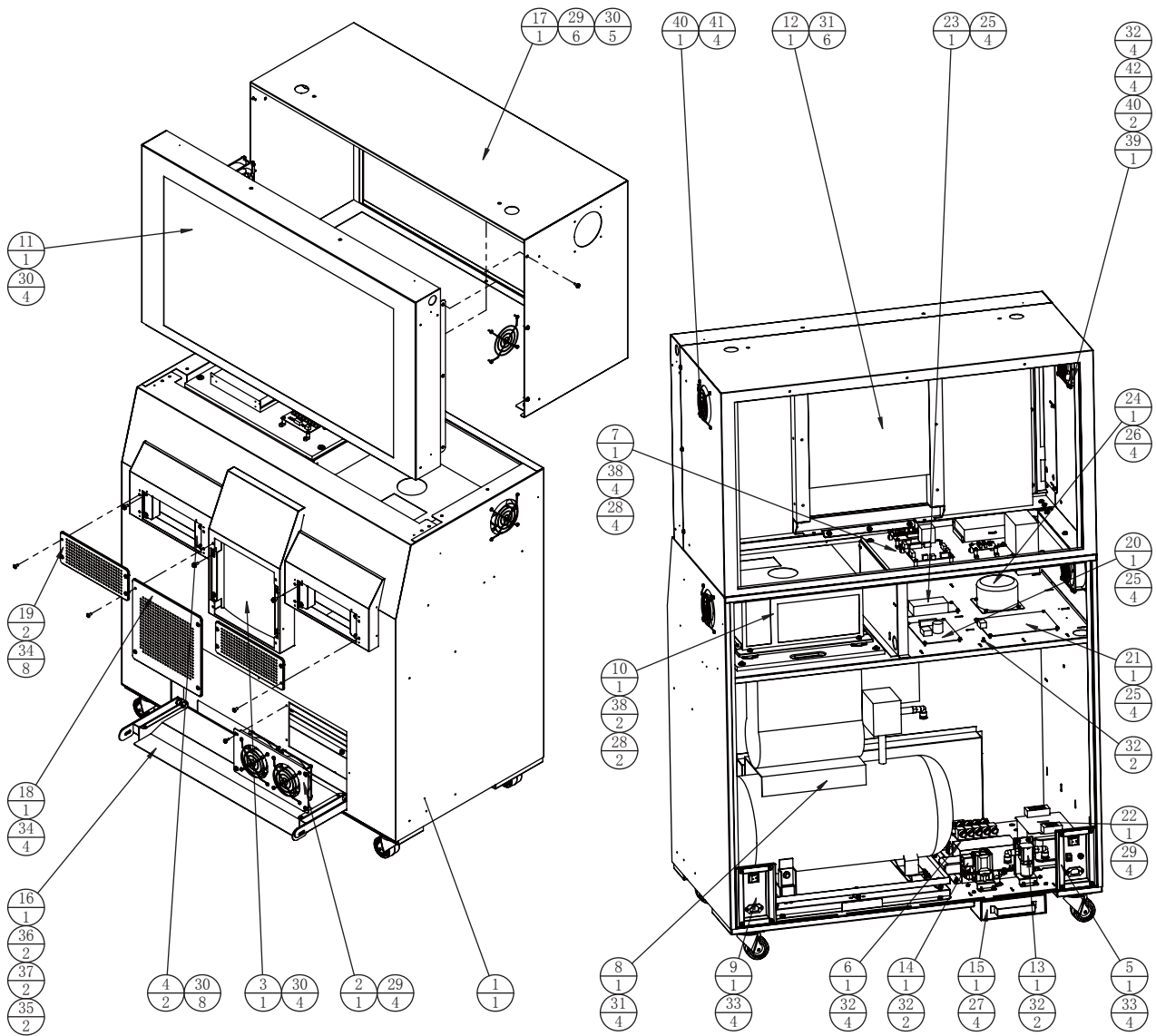

21		IO board	GKP-IO-2015-0501	1	1.4.IC900024	42		Cross recessed cheese head screws	M4*50 (chrome)	4	1.6.LS745012
20		Motion board	GKP-Vibrator-2013-0502	1	1.4.IC901790	41		Truss Screws	M4*12 (chrome)	4	1.6.LS241022
19	SRH-0100D02	Speaker acrylic 2	PMMA-5.0T	2	1.7.WA16C00050	40		Fan cover	120*120	3	1.4.FS300020
18	SRH-0100D01	Speaker acrylic 1	PMMA-5.0T	1	1.7.WA16C00040	39		Fan	120*120*AC110V	1	1.4.FS200042
17	SRH-0100A02	Screen back cover plate		1	1.1.WA16C00140	38		Flat washer	Φ6*Φ20*2.0 (Black)	6	1.6.DP106061
16	SRH-0100A01	Connecting iron plate		1	1.1.WA16C00130	37		Spring washer	M8 (Black)	2	1.6.DP208011
15	SRH-0115000	Sink components		1		36		Flat washer	Φ8*Φ16*2.0 (Black)	2	1.6.DP108011
14	SRH-0114000	Fluid control valve assembly		1		35		Inner six angle screw	M8*20 (Black)	2	1.6.LS8M2011
13	SRH-0113000	Filter assembly		1		34		Cross recessed flat head screw	M6*12 (Black)	12	1.6.LS261021
12	SRH-0112000	LCD assembly		1		33		Cross recessed flat head screw	M5*12 (Black)	8	1.6.LS251021
11	SRH-0111000	LCD glass assembly		1		32		Hexagon nut with flange	M4 (Colour)	14	1.6.LM204013
10	SRH-0110000	Host assembly		1		31		Cross recessed fillister head three-combination screw	M6*16 (Black)	10	1.6.LS861031
9	SRH-0109000	Air compressor power-pack assembly		1		30		Cross recessed fillister head three-combination screw	M6*12 (Black)	21	1.6.LS861021
8	SRH-0108000	Air compressor assembly		1		29		Cross recessed fillister head three-combination screw	M5*12 (Black)	14	1.6.LS851021
7	SRH-0107000	Control-card assembly		1		28		Cross recessed fillister head three-combination screw	M4*12 (Black)	6	1.6.LS842021
6	SRH-0106000	Pneumatic valve components		1		27		Cross recessed fillister head three-combination screw	M4*12 (Black)	4	1.6.LS841021
5	SRH-0105000	Power-pack assembly		1		26		Cross recessed fillister head three-combination screw	M4*8 (Black)	4	1.6.LS840021
4	SRH-0104000	Subwoofer assembly		2		25		Cross recessed fillister head three-combination screw	M3*8 (chrome)	12	1.6.LS830022
3	SRH-0103000	Woofer assembly		1		24		Toroidal transformer	220V/110V/16-0-16V 250W	1	1.4.BY307010
2	SRH-0102000	Lower-frame fan assembly		1		23		Vibration speaker drive board	GKP-VSB-2013-0503	1	1.4.IC901800
1	SRH-0101000	Lower-frame assembly		1		22		Transformer - 220V	AC220V@AC110V@AC110V	1	1.4.BY111010
No.	Draw No.	Name	Material/Spec.	Qty.	Product Code	No.	Draw No.	Name	Material/Spec.	Qty.	Product Code

6.3.1 Lower-frame assembly

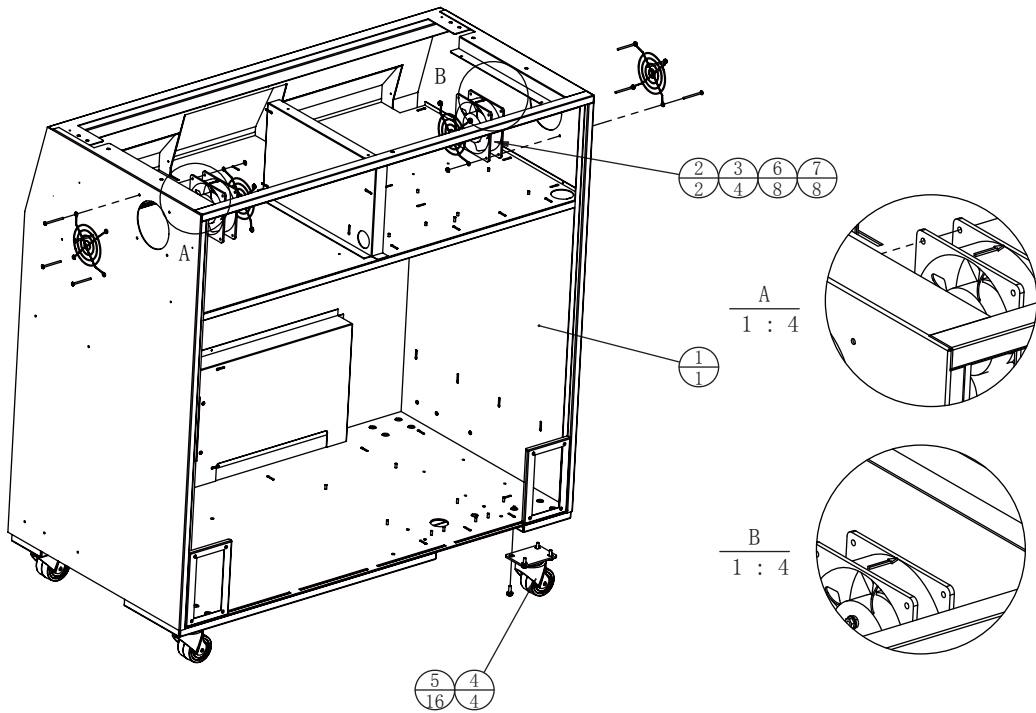

7		Hexagon nut with flange	M4 (Colour)	8	1.6.LM204013
6		Cross recessed fillister head screw	M4*50 (chrome)	8	1.6.LS745012
5		Cross recessed fillister head three-combination screw	M6*16 (Black)	16	1.6.LS861031
4		Rolling wheel	2.5"	4	1.4.JL302520
3		fan cover	120*120	4	1.4.FS300020
2		Fan with bearing	120*120/AC110V	2	1.4.FS200042
1	SRH-0101A01	Below cabinet		1	1.1.WA16C00150
No.	Draw No.	Name	Material/Spec.	Qty.	Product Code

6.3.2 Lower-frame fan assembly

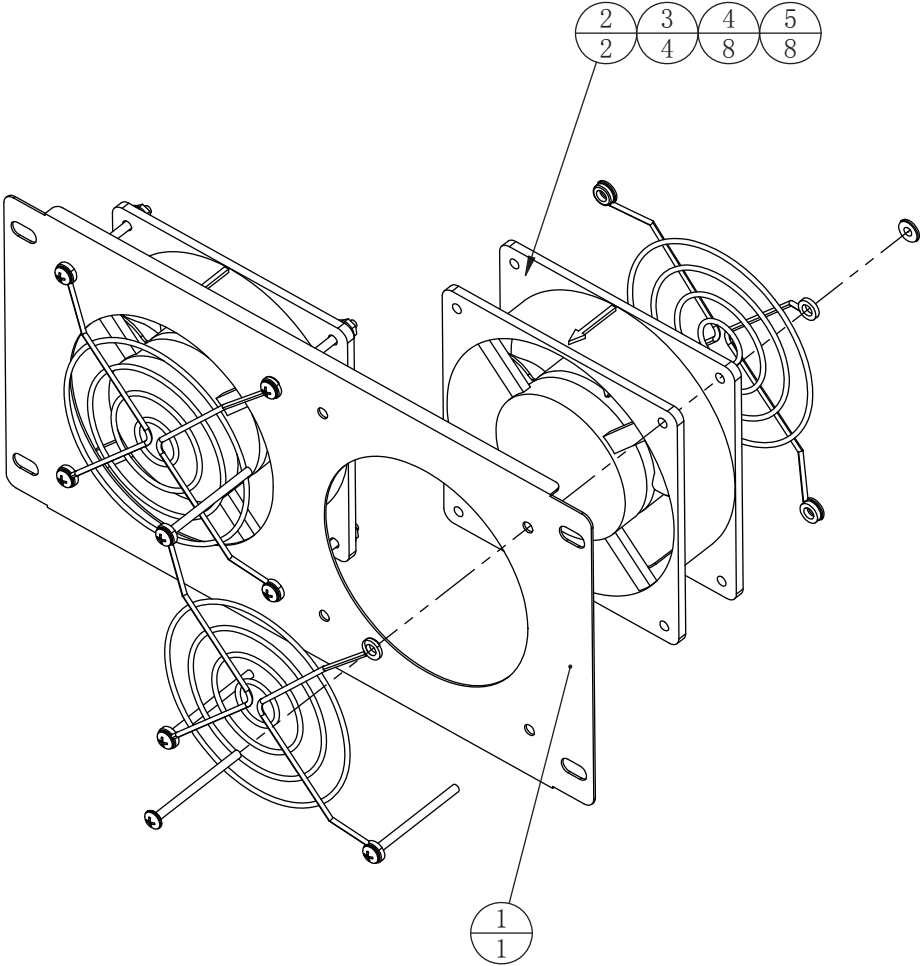

5		Hexagon nut with flange	M4 (Colour)	8	1.6.LM204013
4		Cross recessed fillister head screw	M4*50 (chrome)	8	1.6.LS745012
3		fan cover	120*120	4	1.4.FS300020
2		Fan with bearing	120*120/AC110V	2	1.4.FS200042
1	SRH-0102A01	Fan fixed iron	SPCC-1.0T	1	1.1.WA16C00160
No.	Draw No.	Name	Material/Spec.	Qty.	Product Code

6.3.3 Woofer assembly

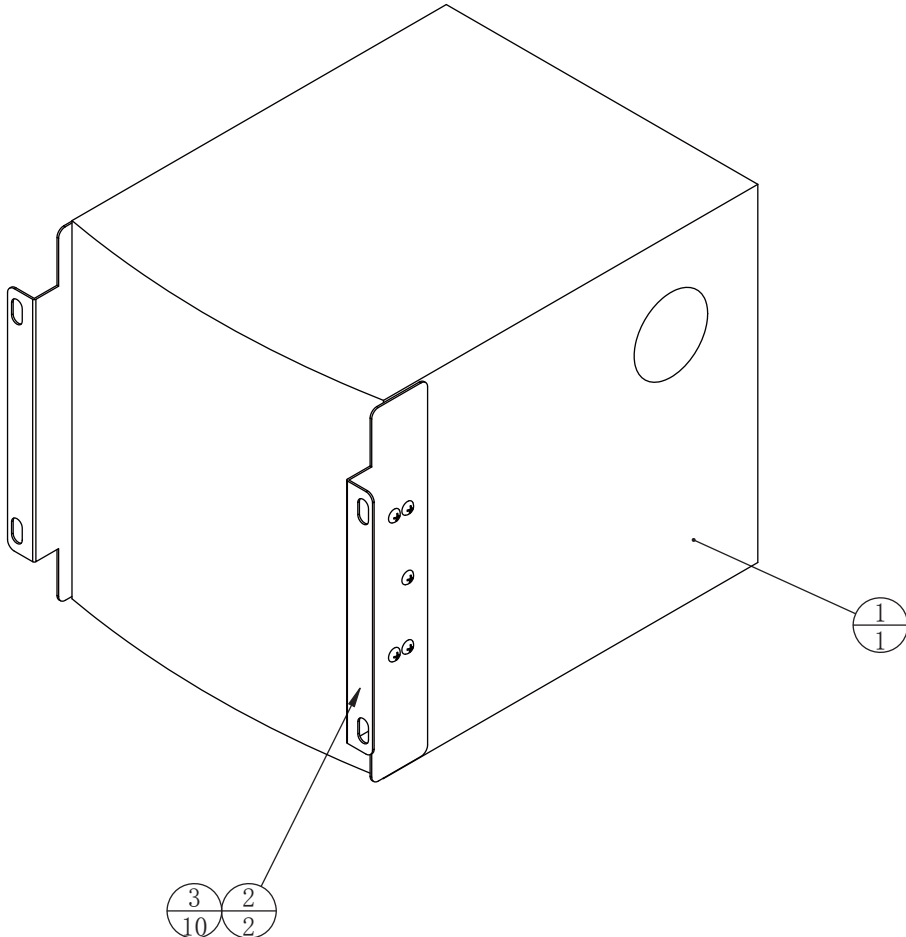

3		Cross recessed flat head self-tapping screw	M4*12 (Black)	10	1.6.LS341021
2	SRH-0103A01	Speaker fixed iron 1	SECC-1.2T	2	1.1.WA16C00170
1		2.1 sound channel speaker (Low)	2.1/100V~240V(E3280)	1	1.4.YSB00050
No.	Draw No.	Name	Material/Spec.	Qty.	Product Code

6.3.4 Subwoofer assembly

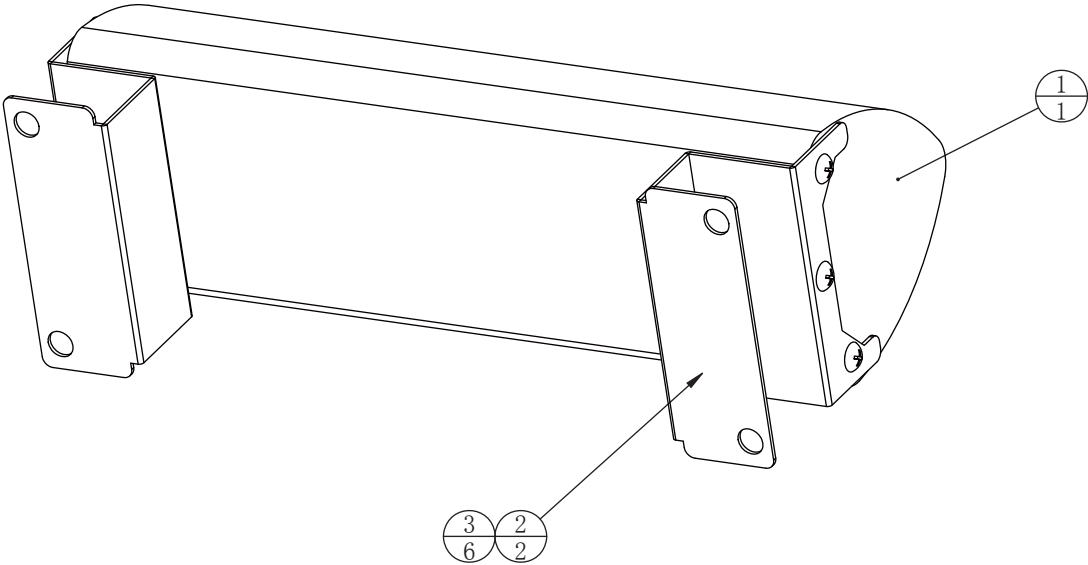

3		Cross recessed flat head self-tapping screw	M4*12 (Black)	6	1.6.LS341021
2	SRH-0104A01	Speaker fixed iron 2	SECC-1.2T	2	1.1.WA16C00180
1		2.1 sound channel speaker (mediant)	2.1/100V~240V(E3280)	1	1.4.YSB00050
No.	Draw No.	Name	Material/Spec.	Qty.	Product Code

6.3.5 Power-pack assembly

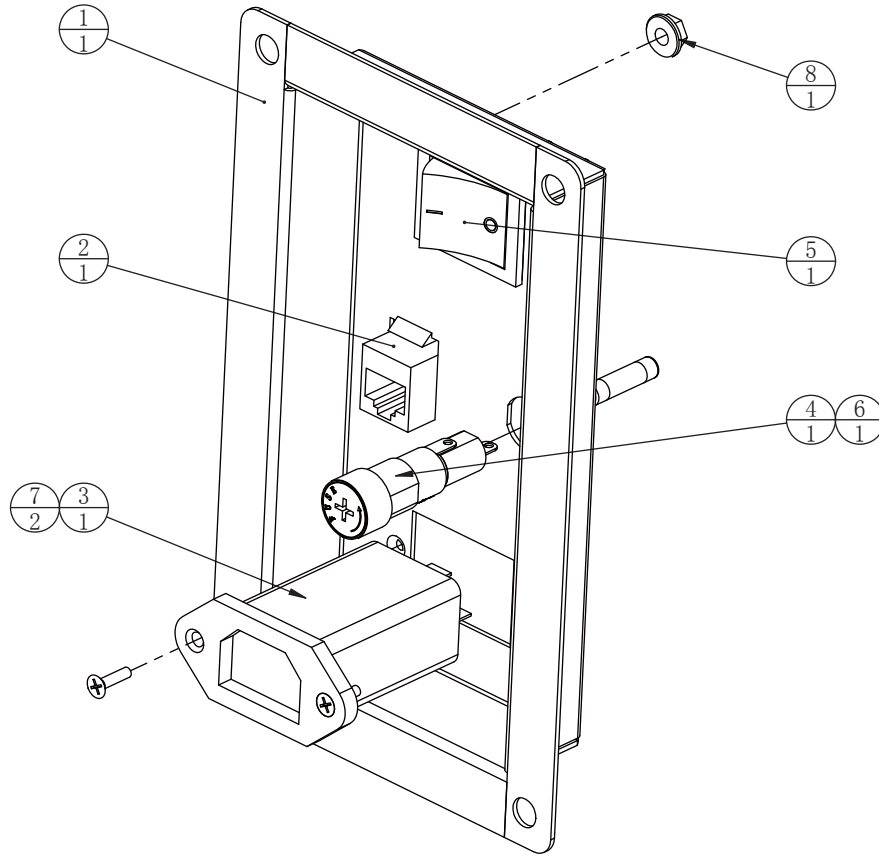

8		Hexagon nut with flange	M4 (Colour)	1	1.6.LM204013
7		Cross recessed countersunk head screw	M3*10 (chrome)	2	1.6.LSC31012
6		Fuse tube	F8A/5*20 250V	1	1.4.BX108020
5		Rocker switch	4P KCD7-2211N	1	1.4.SW604010
4		Fuse plug	MF527A	1	1.4.BX300010
3		Filter with AC switch	YB11A2-15A-Q	1	1.4.LB100080
2		Network adapter		1	1.4.JG072090
1	SRH-0105A01	Power Supply box	SPCC-1.2T	1	1.1.WA16C00190
No.	Draw No.	Name	Material/Spec.	Qty.	Product Code

6.3.6 Pneumatic valve components

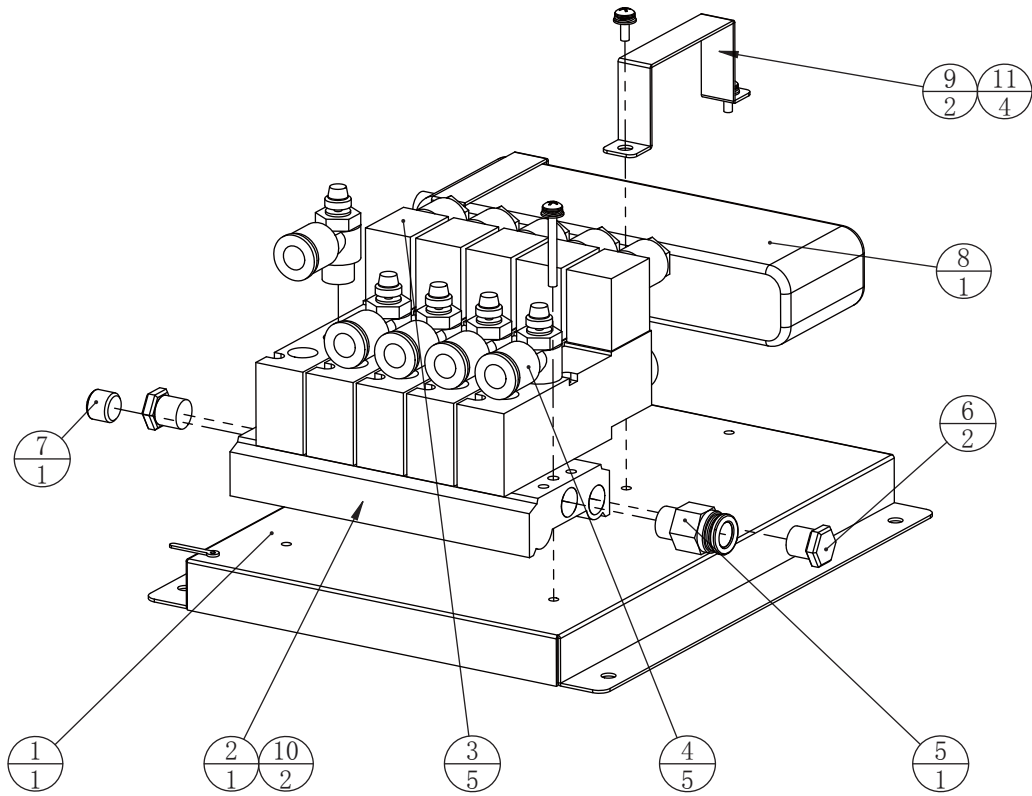

11		Cross recessed fillister head three-combination screw	M4*8 (Black)	4	1.6.LS840021
10		Cross recessed fillister head three-combination screw	M4*30 (Black)	2	1.6.LS843011
9	SRH-0106A02	Socket fixed iron	SECC-1.2T	2	1.1.WA16C00210
8		Multi socket	GN-K014	1	1.5.XC202020
7		Hexagon end cap	ABP-02	1	1.4.JG091030
6		Brass silencer	BSLM02	2	1.4.YSE00020
5		screw thread direct connector	APC10-02	1	1.4.JG082030
4		One-way throttle valve - pipe connector	ASL10-02B	5	1.4.JG09A030
3		Electromagnetic valve	3V210-08-NC-F	5	1.4.JG09A050
2		Pneumatic control valve base	3V200M-5F	1	1.4.QC000010
1	SRH-0106A01	Electromagnetic valve fixed seat	SPCC-1.2T	1	1.1.WA16C00200
No.	Draw No.	Name	Material/Spec.	Qty.	Product Code

6.3.7 Control-card assembly

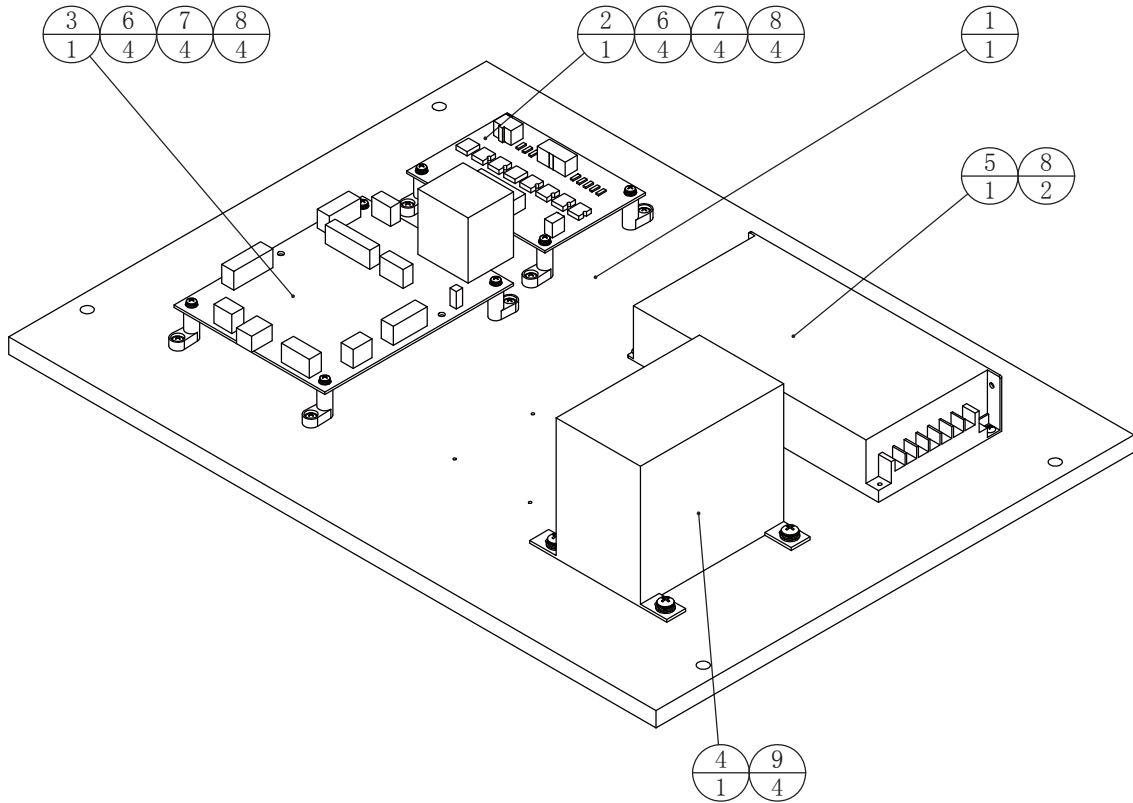

9		Cross recessed fillister head three-combination screw	M5*16 (Black)	4	1.6.LS851021
8		Cross recessed flat head self-tapping screw	M3*12 (chrome)	10	1.6.LS331022
7		Cross recessed fillister head three-combination screw	M3*8 (chrome)	8	1.6.LS830022
6		L-holder	M3mm	8	1.9.LX103010
5		Power Supply box	RS-150-12	1	1.4.DY06A010
4		Transformer - 220V	350W 110V/110V-14V	1	1.4.BY203040
3		Control card (version 1)	cdckp0410000000	1	1.3.WA16C00010#
2		8 axle air pressure extend card	cdpnc0110000000	1	1.3.WA16C00030#
1	SRH-0107B01	IO board mounted wooden plate	MDF-12.0T	1	1.2.WA16C00010
No.	Draw No.	Name	Material/Spec.	Qty.	Product Code

6.3.8 Air compressor assembly

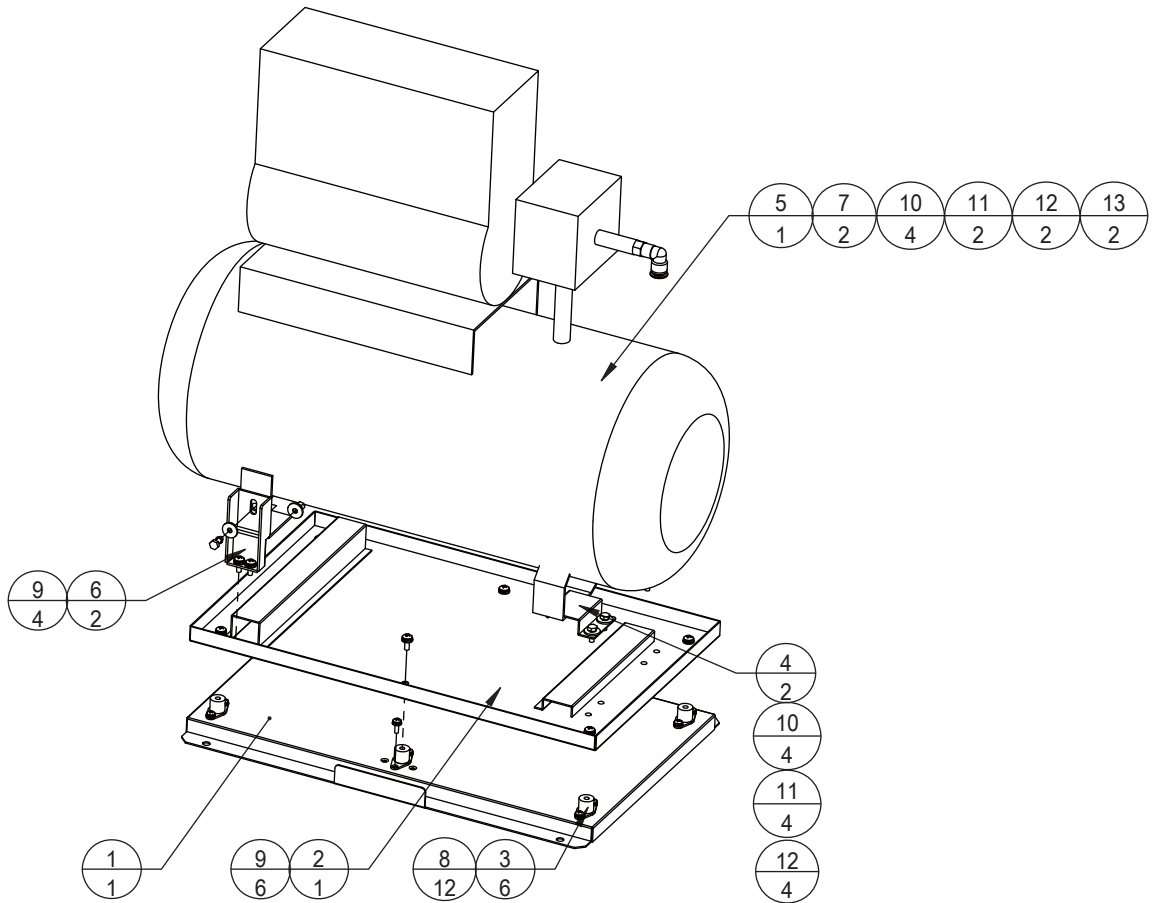

13		Self-locking nut	M6 (Galvanization)	2	1.6.LM306014#
12		External hex socket screw	M6*16 (Black)	6	1.6.LSM61021
11		Spring washer	M6 (Black)	6	1.6.DP206011
10		Flat washer	Φ6*Φ20*2.0 (Black)	8	1.6.DP106061
9		Cross recessed fillister head three-combination screw	M6*12 (Black)	10	1.6.LS861021
8		Cross recessed fillister head three-combination screw	M5*12 (Black)	12	1.6.LS851021
7		L type screw thread connector	APL10-02	2	1.4.JG072110
6	SRH-0108A02	Air compressor fixed iron	SPCC-2.5T	2	1.1.WA16C00230
5		Air compressor	S10(AC220V)	1	1.4.KY100030
4	ME-0102A04	Air compressor pressure iron	SPCC-1.5T	2	1.1.IG22B00330
3		Shockproof base		6	1.8.AA000250
2	ME-0102A02	Air compressor support set		1	1.1.IG22B00310
1	SRH-0108A01	Air compressor shockproof seat		1	1.1.WA16C00220
No.	Draw No.	Name	Material/Spec.	Qty.	Product Code

6.3.9 Air compressor power-pack assembly

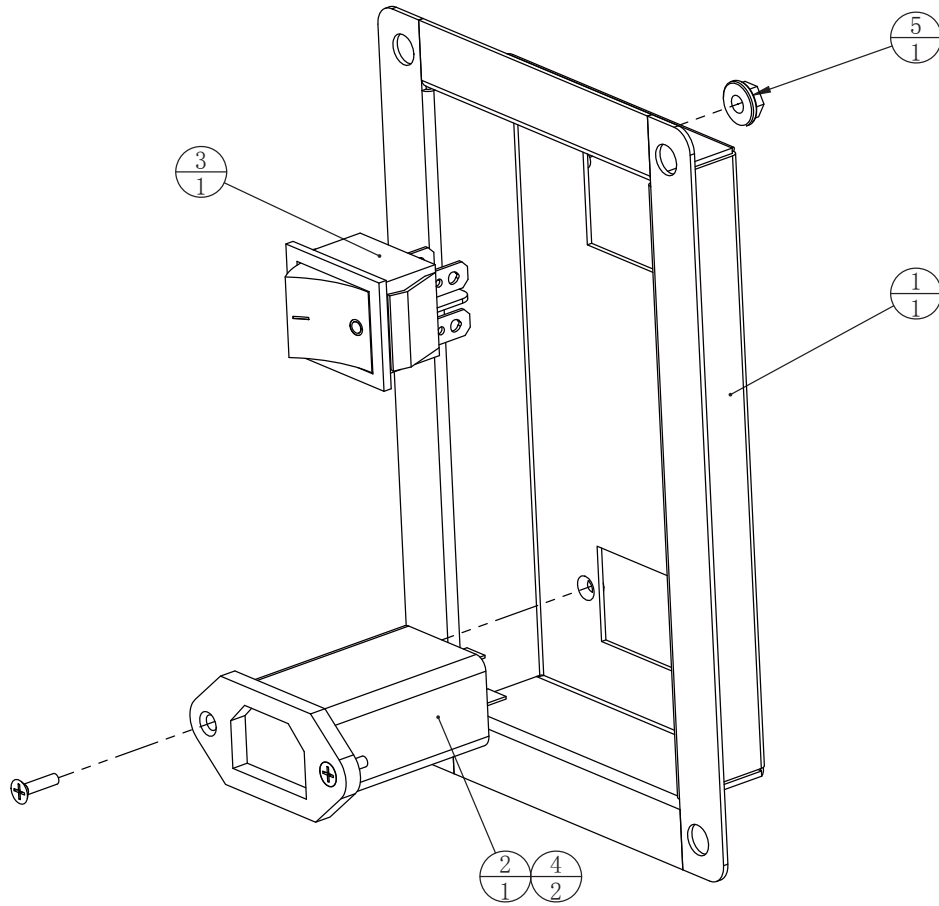

5		Hexagon nut with flange	M4 (Colour)	1	1.6.LM204013
4		Cross recessed countersunk head screw	M3*10 (chrome)	2	1.6.LSC31012
3		Rocker switch	4P KCD7-2211N	1	1.4.SW604010
2		Filter with AC switch	YB11A2-15A-Q	1	1.4.LB100080
1	SRH-0109A01	Air compressor power supply box	SPCC-1.2T	1	1.1.WA16C00240
No.	Draw No.	Name	Material/Spec.	Qty.	Product Code

6.3.10 Host assembly

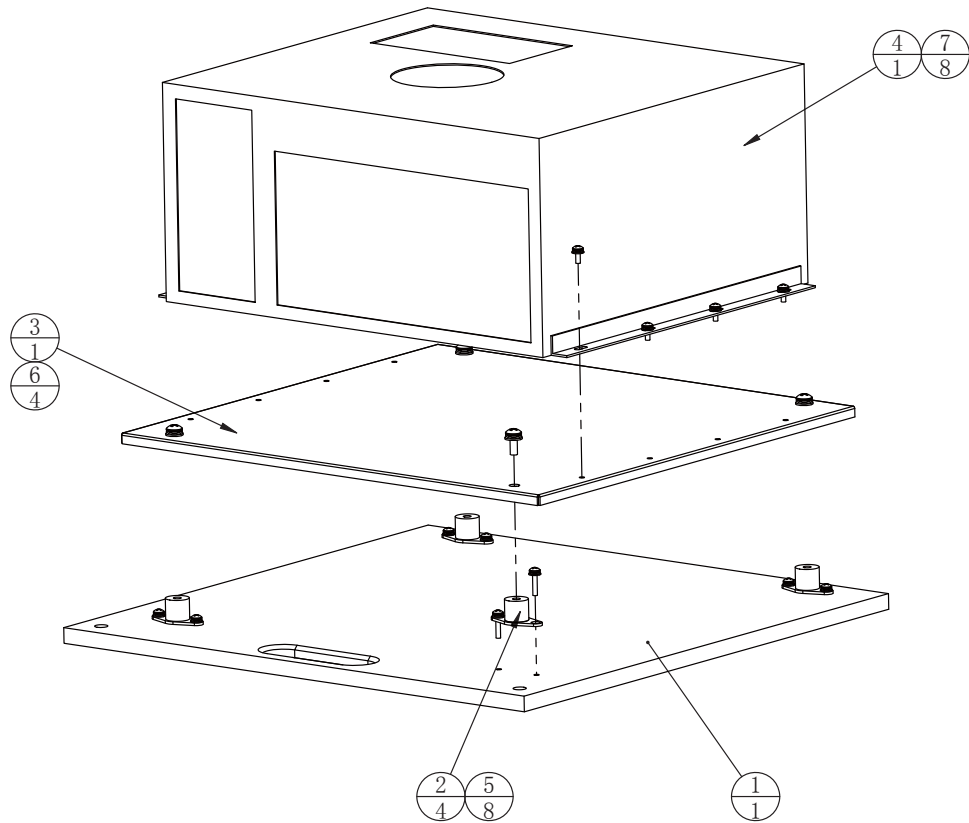

7		Cross recessed fillister head three-combination screw	M4*8 (Black)	8	1.6.LS840021
6		Cross recessed fillister head three-combination screw	M6*12 (Black)	4	1.6.LS861021
5		Cross recessed fillister head three-combination screw	M4*16 (Black)	8	1.6.LS841031
4		Main PC set	IPC-WL001-G860	1	1.4.ZJ010026
3	SRH-0110A01	Main PC set fixed iron	SECC-1.5T	1	1.1.WA16C00250
2		Shockproof base		4	1.8.AA000250
1	SRH-0110B01	Main PC set mounted wooden plate	MDF-12.0T	1	1.2.WA16C00020
No.	Draw No.	Name	Material/Spec.	Qty.	Product Code

6.3.11 LCD glass assembly

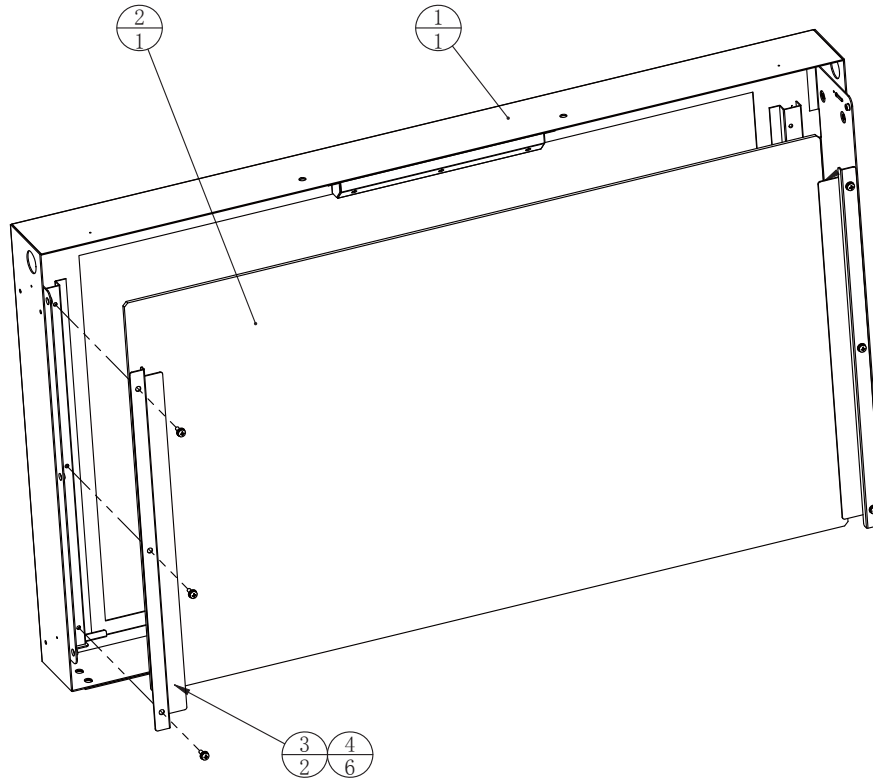

4		Cross recessed fillister head three-combination screw	M5*12 (Black)	6	1.6.LS851021
3	SRH-0111A02	Glass pressure iron	SECC-1.5T	2	1.1.WA16C00270
2	WAH-0000C05	42" LED screen glass A	glass-5.0T	1	1.8.AA030050
1	SRH-0111A01	LCD screen frame		1	1.1.WA16C00260
No.	Draw No.	Name	Material/Spec.	Qty.	Product Code

6.3.12 LCD assembly

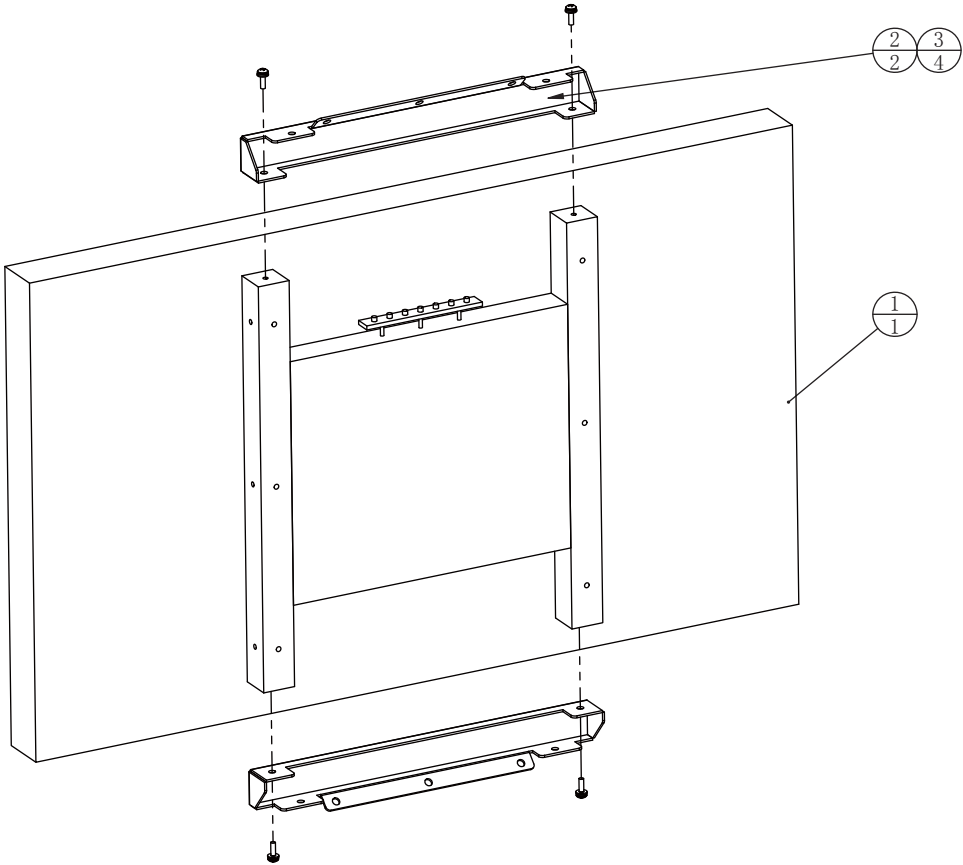

3		Cross recessed fillister head three-combination screw	M6*16 (Black)	4	1.6.LS861031
2	TAS-0201A01	LCD screen cushion block	SECC-2.5T	2	1.1.WA12B00260
1		screen with frame		1	1.4.XS404250
No.	Draw No.	Name	Material/Spec.	Qty.	Product Code

6.3.13 Filter assembly

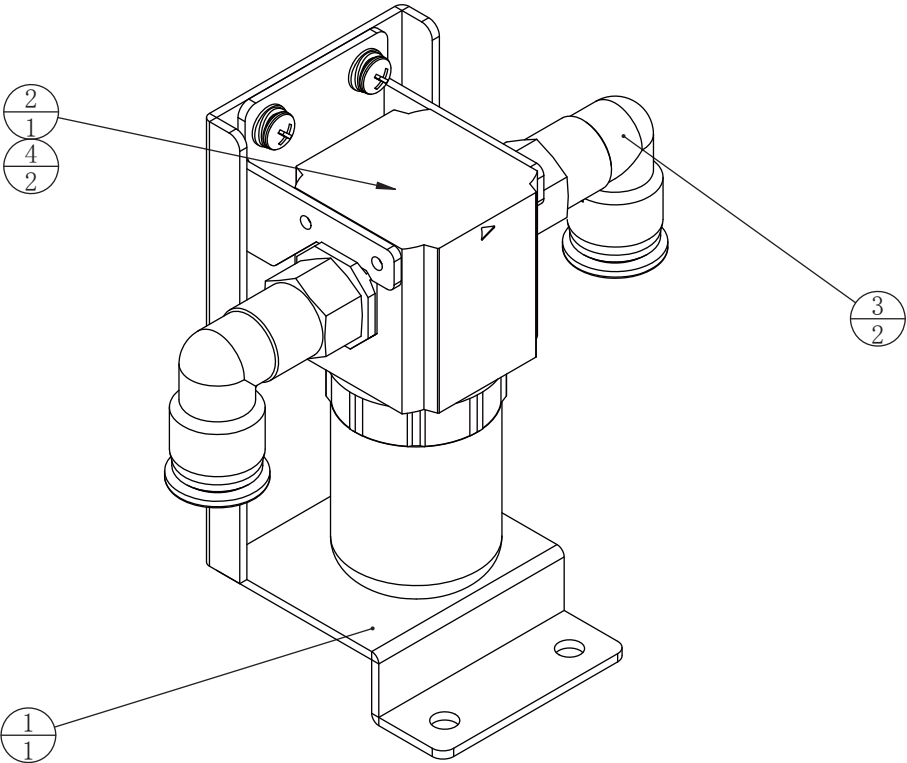

4		Cross recessed fillister head three-combination screw	M4*8 (Black)	2	1.6.LS840021
3		L type screw thread connector	APL10-02	2	1.4.JG072110
2		Filtrator	CF200-08	1	1.4.LB200020
1	SRH-0113A01	Filter fixed iron	SPCC-1.5T	1	1.1.WA16C00280
No.	Draw No.	Name	Material/Spec.	Qty.	Product Code

6.3.14 Fluid control valve assembly

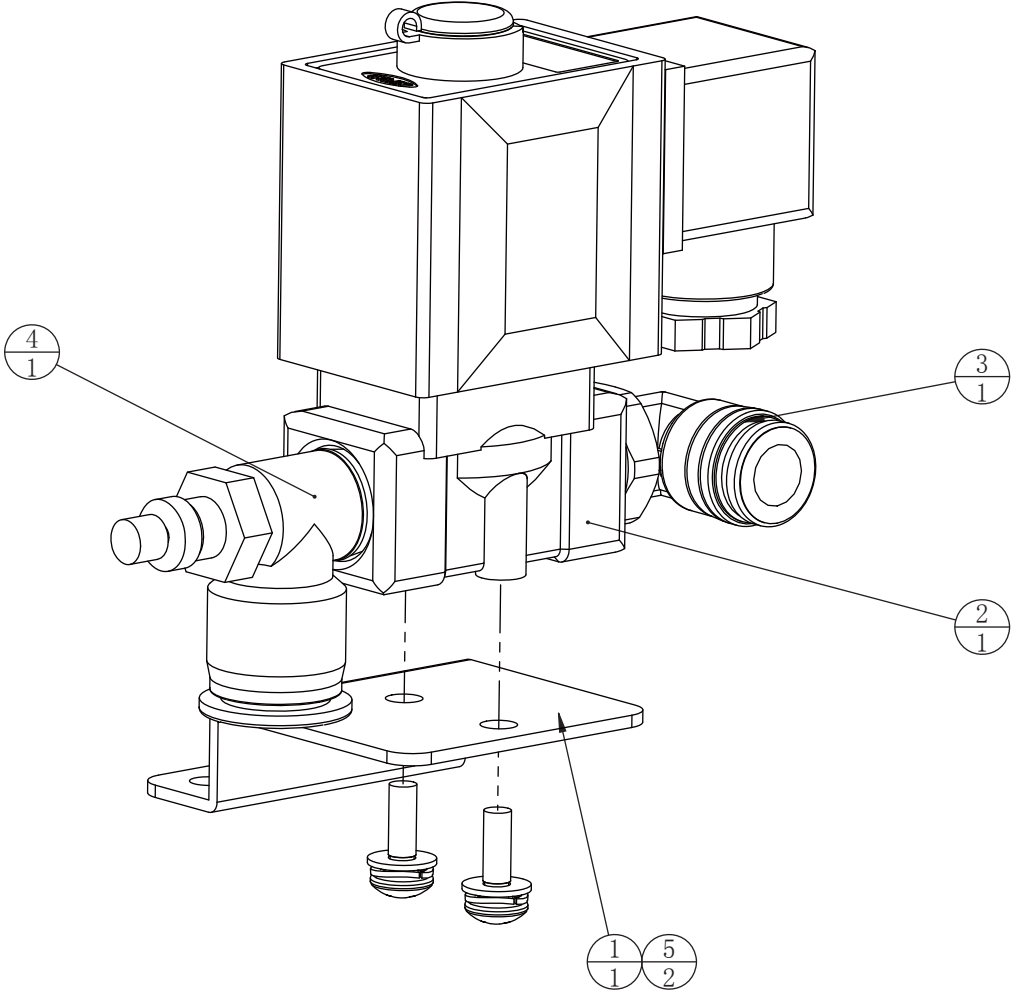

5		Cross recessed fillister head three-combination screw	M5*12 (Black)	2	1.6.LS851021
4		One-way throttle valve - pipe connector	ASL10-04B	1	1.4.JG09A020
3		L type screw thread connector	APL10-04	1	1.4.JG072100
2		Fluids control valve	2KW050-15-F	1	1.4.JG09A040
1	SRH-0114A01	Two in-exit electromagnetic valve fixed iron	SPCC-1.5T	1	1.1.WA16C00290
No.	Draw No.	Name	Material/Spec.	Qty.	Product Code

6.3.15 Sink components

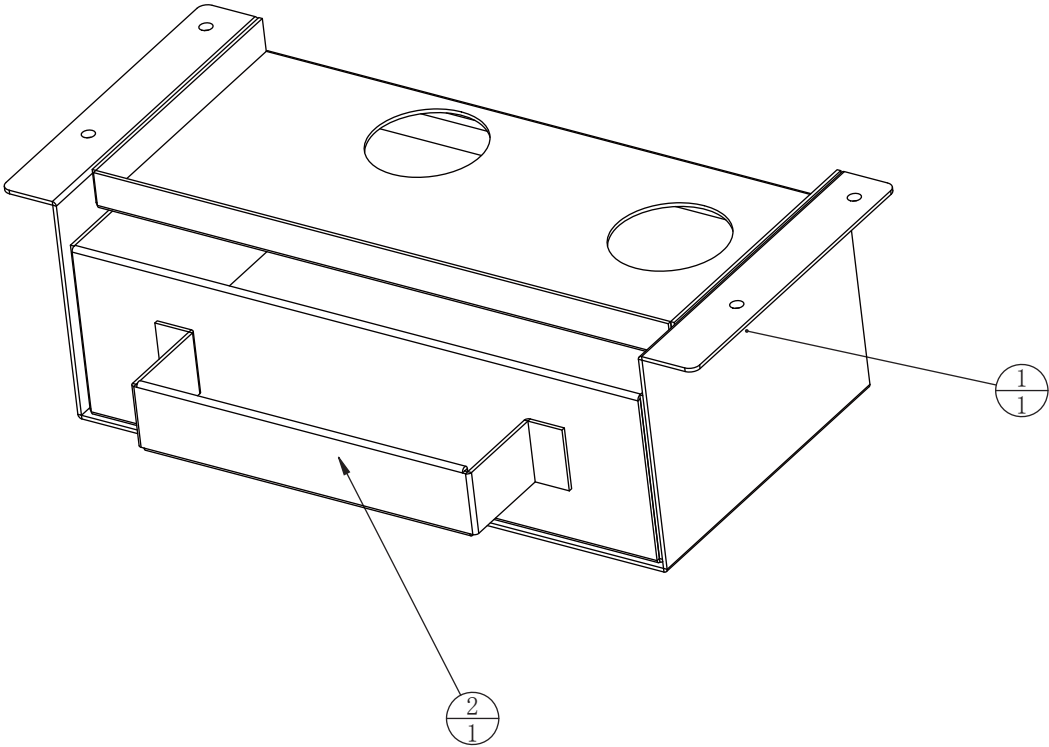

2	SRH-0115A02	Flume		1	1.1.WA16C00310
1	SRH-0115A01	Flume fixed plate		1	1.1.WA16C00300
No.	Draw No.	Name	Material/Spec.	Qty.	Product Code

6.4 Seat-base assembly

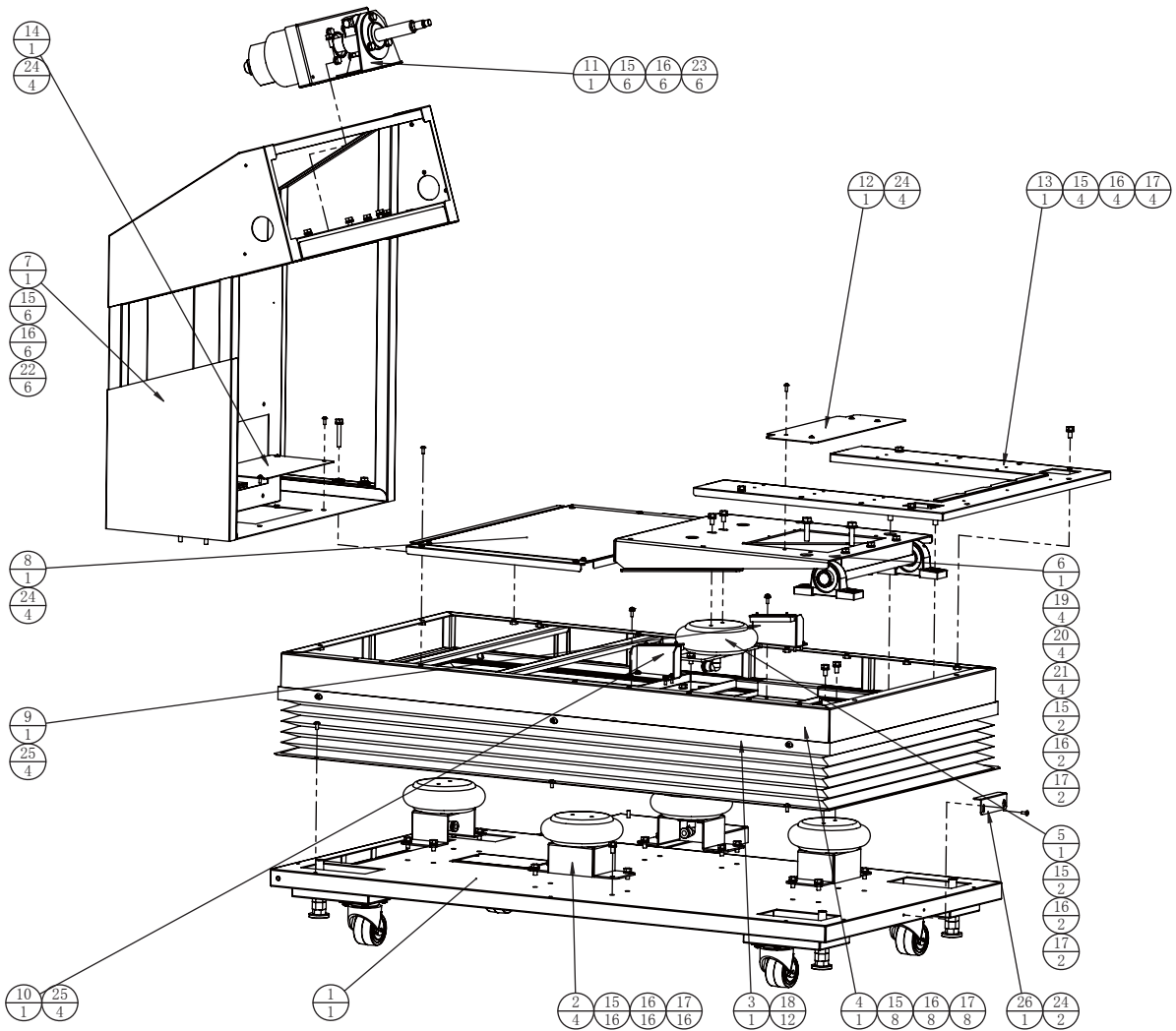

13	SRH-0200A05	Cover plate 2	SPCC-1.5T	1	1.1.WA16C00360	26	SRH-0200A07	Dust cover pressing iron	SPCC-1.5T	1	1.1.WA16C00650
12	SRH-0200A04	Cover plate 1	SPCC-1.5T	1	1.1.WA16C00350	25		Cross recessed fillister head three-combination screw	M5*12 (Black)	8	1.6.LS851021
11	SRH-0208000	Motor assembly		1		24		Cross recessed flat head screw	M5*12 (Black)	14	1.6.LS251021
10	SRH-0207000	Limiting components (2)		1		23		External hex socket screw	M8*20 (Black)	6	1.6.LSM82011
9	SRH-0206000	Limiting components (1)		1		22		External hex socket screw	M8*50 (Black)	6	1.6.LSM85011
8	SRH-0205000	Pedal assembly		1		21		External hex socket screw	M10*40 (Black)	4	1.6.LSM04011
7	SRH-0200A03	Control panel		1	1.1.WA16C00340	20		Spring washer	M10 (Black)	4	1.6.DP110011
6	SRH-0204000	Seat active-plate assembly		1		19		Flat washer	φ12*φ23*2.0 (Black)	4	1.6.DP112011
5	SRH-0203000	Seat airbag assembly		1		18		Cross recessed flat head screw	M6*12 (Black)	12	1.6.LS261021
4	SRH-0200A02	Seat		1	1.1.WA16C00330	17		External hex socket screw	M8*16 (Black)	32	1.6.LSM81021
3	SRH-0200A01	Dust cover		1	1.1.WA16C00320	16		Spring washer	M8 (Black)	44	1.6.DP208011
2	SRH-0202000	Airbag assembly		4		15		Flat washer	φ8*φ16*2.0 (Black)	44	1.6.DP108011
1	SRH-0201000	Seat-base assembly		1		14	SRH-0200A06	Cover plate 3	SPCC-1.5T	1	1.1.WA16C00370
No.	Draw No.	Name	Material/Spec.	Qty.	Product Code	No.	Draw No.	Name	Material/Spec.	Qty.	Product Code

6.4.1 Seat-base assembly

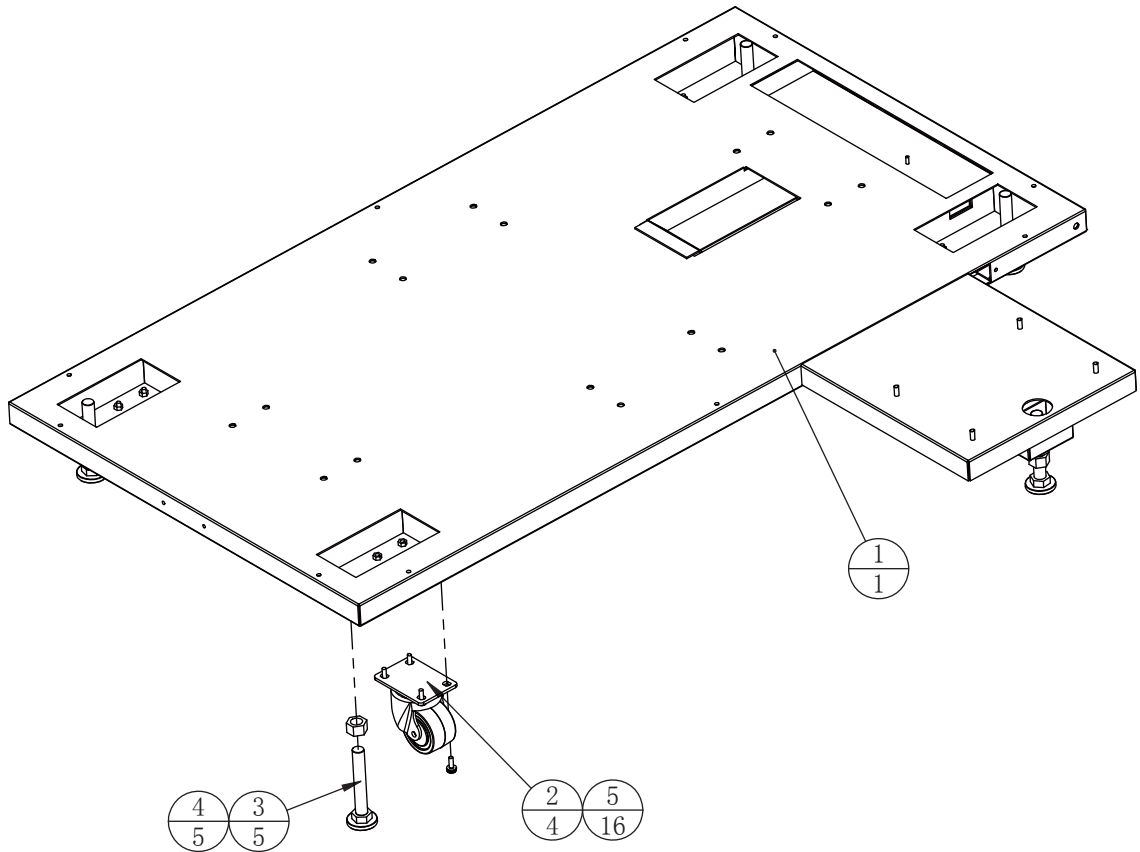

5		Cross recessed fillister head three-combination screw	M6*16 (Black)	16	1.6.LS861031
4		Hexagon nut	M16 (Colour)	5	1.6.LM116013
3		Anchor screw	M16*Y100 (Colour)	5	1.6.LSV99013
2		Rolling wheel	2.5"	4	1.4.JL302520
1	SRH-0201A01	Seat pedestal		1	1.1.WA16C00380
No.	Draw No.	Name	Material/Spec.	Qty.	Product Code

6.4.2 Airbag assembly

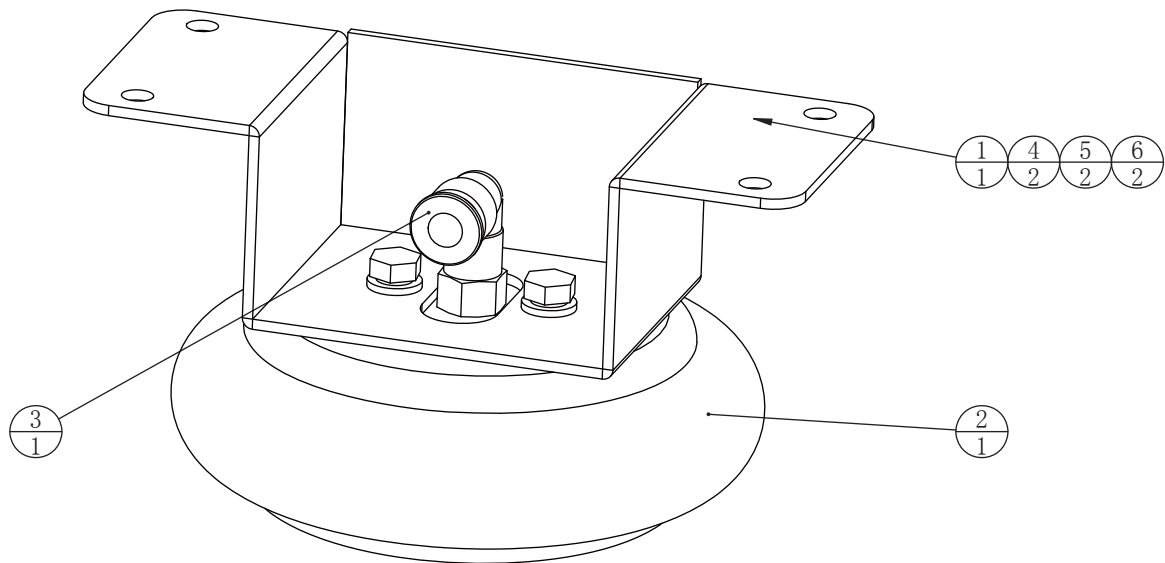

6		External hex socket screw	M8*16 (Black)	2	1.6.LSM81021
5		Spring washer	M8 (Black)	2	1.6.DP208011
4		Flat washer	φ8*φ16*2.0 (Black)	2	1.6.DP108011
3		L type screw thread connector	APL10-02	1	1.4.JG072110
2		Air bag	1B5002	1	1.4.QL000020
1	SRH-0202A01	Air bag fixed iron	SPCC-3.0T	1	1.1.WA16C00390
No.	Draw No.	Name	Material/Spec.	Qty.	Product Code

6.4.3 Seat airbag assembly

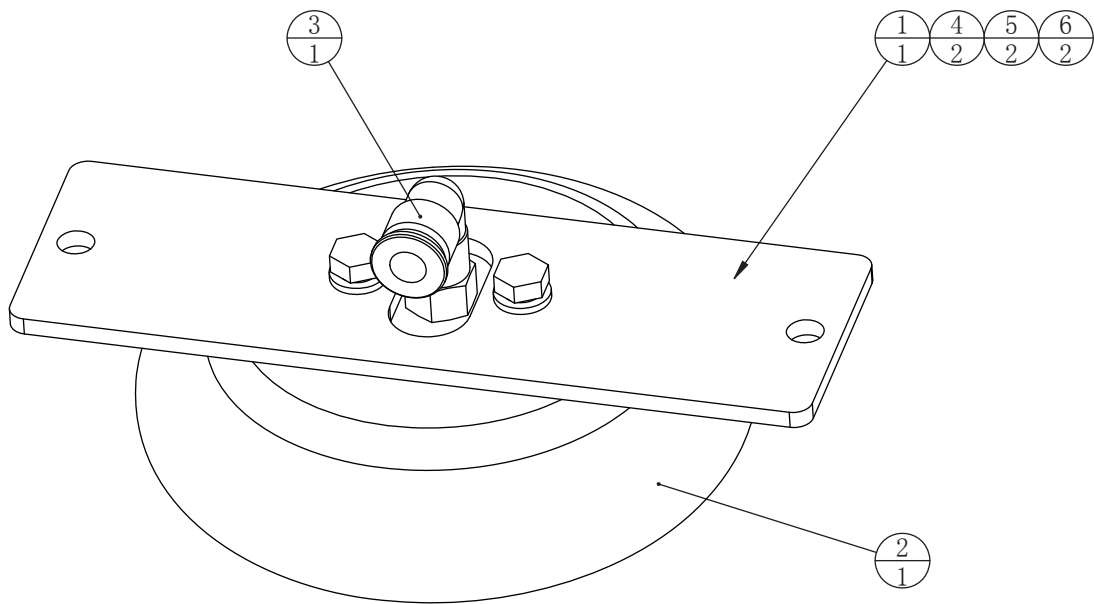

6		External hex socket screw	M8*16 (Black)	2	1.6.LSM81021
5		Spring washer	M8 (Black)	2	1.6.DP208011
4		Flat washer	φ8*φ16*2.0 (Black)	2	1.6.DP108011
3		L type screw thread connector	APL10-02	1	1.4.JG072110
2		Air bag	1B5002	1	1.4.QL000020
1	SRH-0203A01	Fifth axle air bag fixed iron	SPCC-5.0T	1	1.1.WA16C00400
No.	Draw No.	Name	Material/Spec.	Qty.	Product Code

6.4.4 Seat active-plate assembly

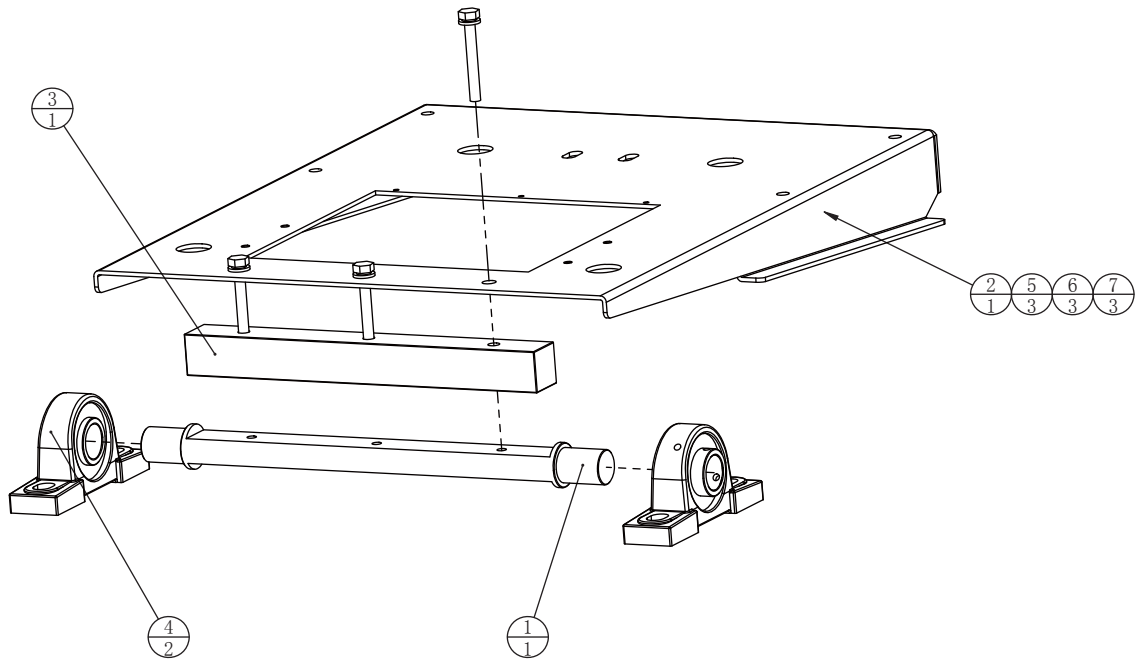

7		External hex socket screw	M8*60 (Black)	3	1.6.LSM86011
6		Spring washer	M8 (Black)	3	1.6.DP208011
5		Flat washer	φ8*φ16*2.0 (Black)	3	1.6.DP108011
4		bearing with pedestal	UCP205	2	1.4.ZC200040
3	SRH-0204A03	Seat cushion fixed plate	Q235	1	1.1.WA16C00430
2	SRH-0204A02	Seat active plate	SPCC-3.0T	1	1.1.WA16C00420
1	SRH-0204A01	Seat swing axle	Q235	1	1.1.WA16C00410
No.	Draw No.	Name	Material/Spec.	Qty.	Product Code

6.4.5 Pedal assembly

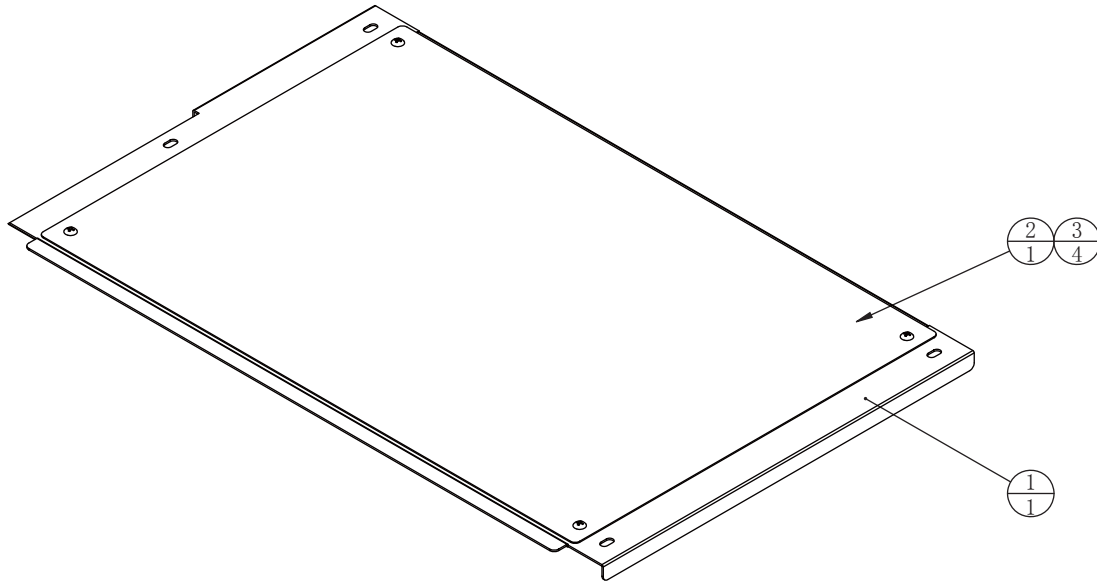

3		Cross recessed flat head screw	M5*12 (chrome)	4	1.6.LS251022
2	SRH-0205A02	Pedal aluminium plate		1	1.1.WA16C00450
1	SRH-0205A01	Pedal cover plate	SPCC-1.5T	1	1.1.WA16C00440
No.	Draw No.	Name	Material/Spec.	Qty.	Product Code

6.4.6 Limiting components (1)

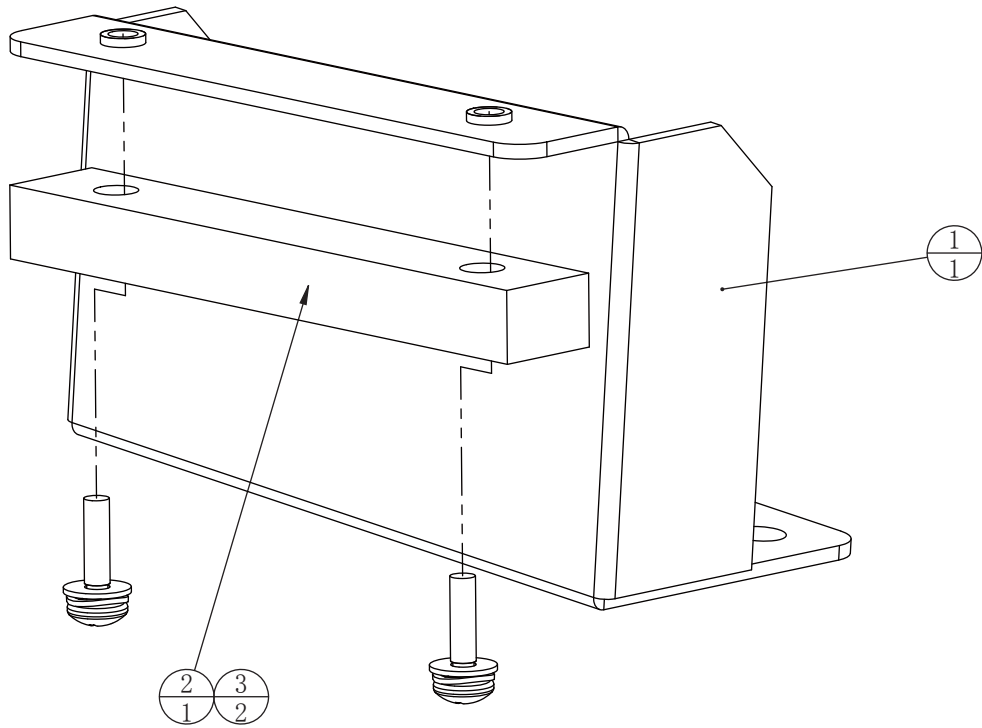

3		Cross recessed filister head three-combination screw	M4*12 (Black)	2	1.6.LS841021
2	SRH-0206C01	Limit replacement glue		1	1.8.WA16C010
1	SRH-0206A01	Limited hardware 1	SPPC-2.0T	1	1.1.WA16C00460
No.	Draw No.	Name	Material/Spec.	Qty.	Product Code

6.4.7 Limiting components (2)

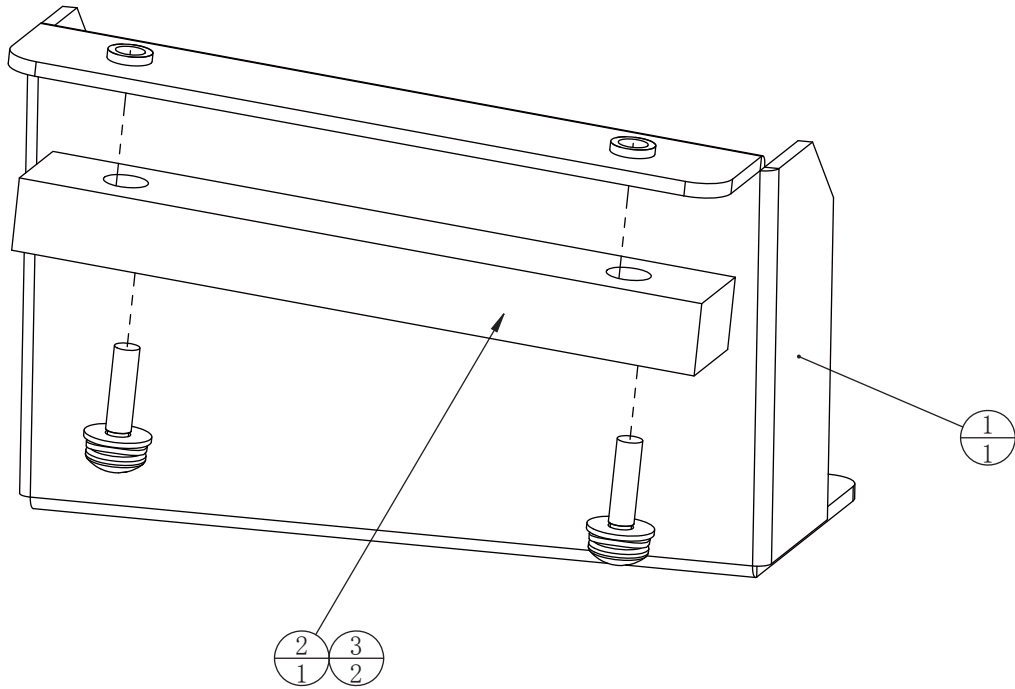

3		Cross recessed fillister head three-combination screw	M4*12 (Black)	2	1.6.LS841021
2	SRH-0206C01	Limit replacement glue		1	1.8.WA16C010
1	SRH-0207A01	Limited hardware 2	SPCC-2.0T	1	1.1.WA16C00470
No.	Draw No.	Name	Material/Spec.	Qty.	Product Code

6.4.8 Motor assembly

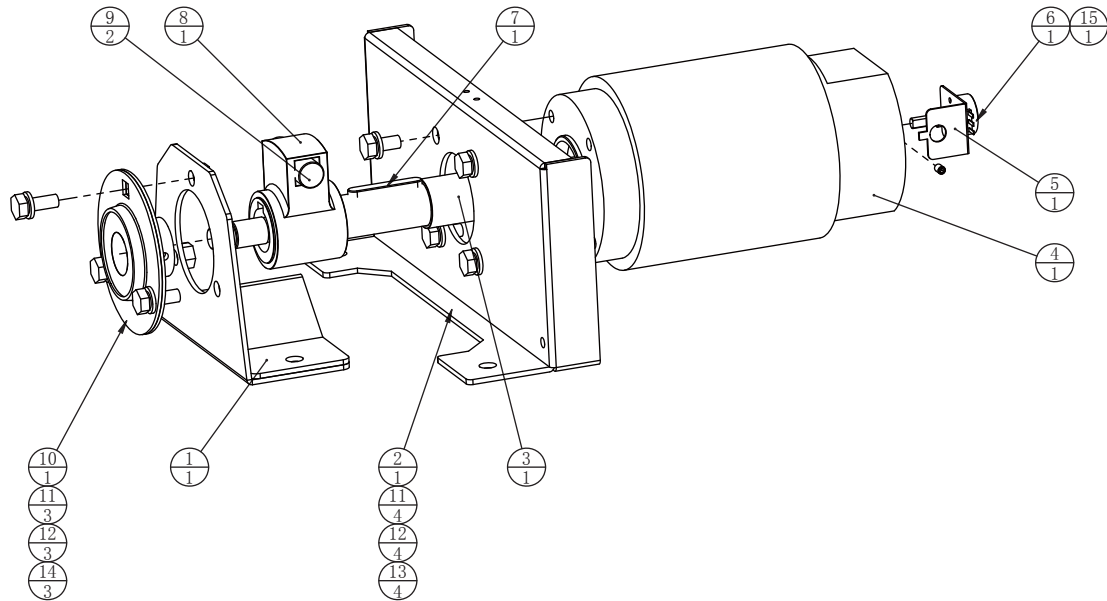

15		Headless hex socket screw	M5*6 (Black)	1	1.6.LST50011
14		External hex socket screw	M8*20 (Black)	3	1.6.LSM82011
13		External hex socket screw	M8*16 (Black)	4	1.6.LSM81021
12		Spring washer	M8 (Black)	7	1.6.DP208011
11		Flat washer	φ8*φ16*2.0 (Black)	7	1.6.DP108011
10		bearing	PF205	1	1.4.ZC001010
9	SR1-0501A05	Swing shaft rubber		2	1.1.WA10A00260
8	SR1-0501A04	Motor swing shaft	45	1	1.1.WA10A00250
7	SR1-0501A03	Swing shaft key	45	1	1.1.WA10A00240
6		Rotating potentiometer	B-5KΩ 270	1	1.4.VR150220#
5	SR1-0501A07	Potentiometer mounted plate	SPCC-1.0	1	1.1.WA10A00280
4		Motor (DC)	112ZY100-40	1	1.4.MD100022
3	SR1-0501A02	Motor shaft case	45	1	1.1.WA10A00230
2	SRF-0102A02	Motor mounted plate	SPCC-3.0T	1	1.1.WA10E00180
1	SRF-0102A01	Motor swing frame support iron	SPCC-3.0T	1	1.1.WA10E00170
No.	Draw No.	Name	Material/Spec.	Qty.	Product Code

6.5 Seat-component assembly

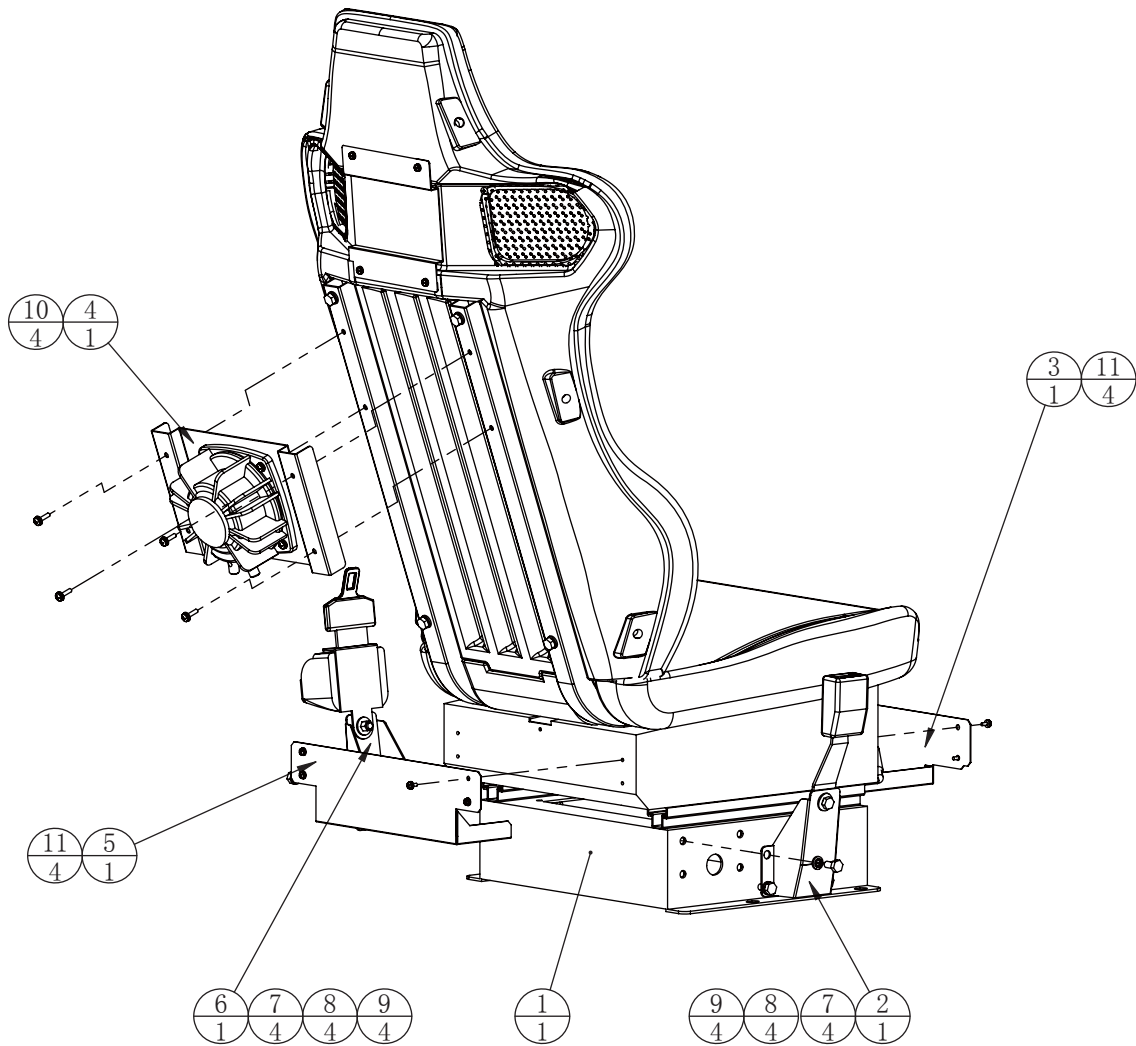

11		Cross recessed fillister head three-combination screw	M4*8 (Black)	8	1.6.LS840021
10		Cross recessed fillister head three-combination screw	M5*16 (Black)	4	1.6.LS851031
9		External hex socket screw	M8*16 (Black)	8	1.6.LSM81021
8		Spring washer	M8 (Black)	8	1.6.DP208011
7		Flat washer	φ8*φ16*2.0 (Black)	8	1.6.DP108011
6	SRH-0303000	Seat-belt roll-end assembly		1	
5	SRH-0300A02	Seat back blocking iron	SPCC-1.0T	1	1.1.WA16C00490
4	SRH-0304000	Vibrating speaker assembly		1	
3	SRH-0300A01	Seat front blocking iron	SPCC-1.0T	1	1.1.WA16C00480
2	SRH-0302000	Seat-belt buckle-end assembly		1	
1	SRH-0301000	Seat assembly		1	
No.	Draw No.	Name	Material/Spec.	Qty.	Product Code

6.5.1 Seat assembly

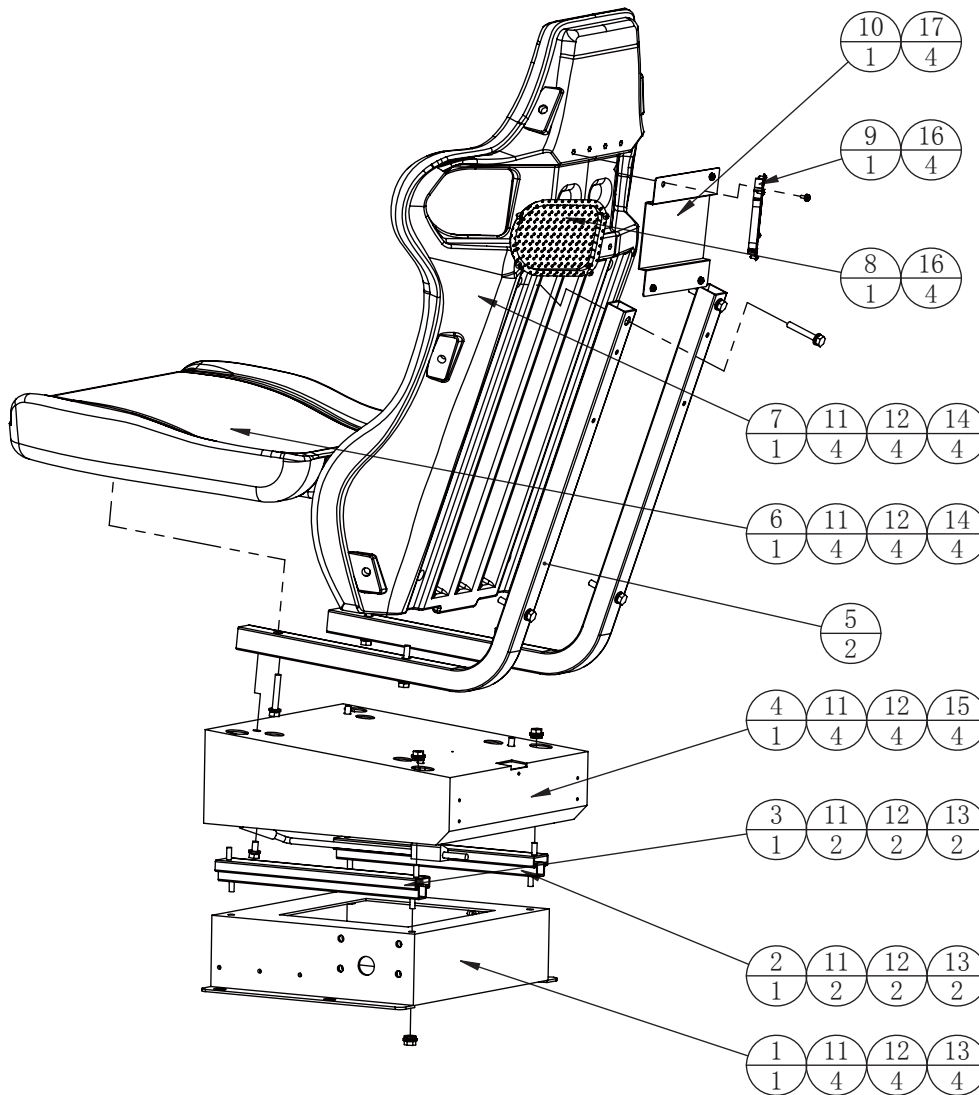

17		Cross recessed fillister head three-combination screw	M4*8 (Black)	4	1.6.LS840021
16		Cross recessed flat head self-tapping screw	M4*8 (Black)	8	1.6.LS341021
15		External hex socket screw	M8*16 (Black)	4	1.6.LSM81021
14		External hex socket screw	M8*50 (Black)	8	1.6.LSM85011
13		Hexagon nut with flange	M8 (Colour)	8	1.6.LM208013
12		Spring washer	M8 (Black)	20	1.6.DP208011
11		Flat washer	ø8*ø16*2.0 (Black)	20	1.6.DP108011
10	SRH-0301A03	Cover pore plate	SPCC-1.0T	1	1.1.WA16C00520
9		Seat speaker cover - left	1.0T	1	1.1.IG041000
8		Seat speaker cover - right	1.0T	1	1.1.IG041001
7	SRF-0202C02	Seat back cushion	ABS	1	1.8.WA10E040
6	SRF-0202C01	Seat cushion	ABS	1	1.8.WA10E030
5	HXK-0501A02	seat bend	30°2/Q235	2	1.1.IG19A00670
4	SRH-0301A02	Seat mounted set	SPCC-2.0T	1	1.1.WA16C00510
3		Slider rail - left		1	1.1.AA030100
2		Slider rail - right		1	1.1.AA030101
1	SRH-0301A01	Seat mounted plate	SPCC-3.0T	1	1.1.WA16C00500
No.	Draw No.	Name	Material/Spec.	Qty.	Product Code

6.5.2 Seat-belt buckle-end assembly

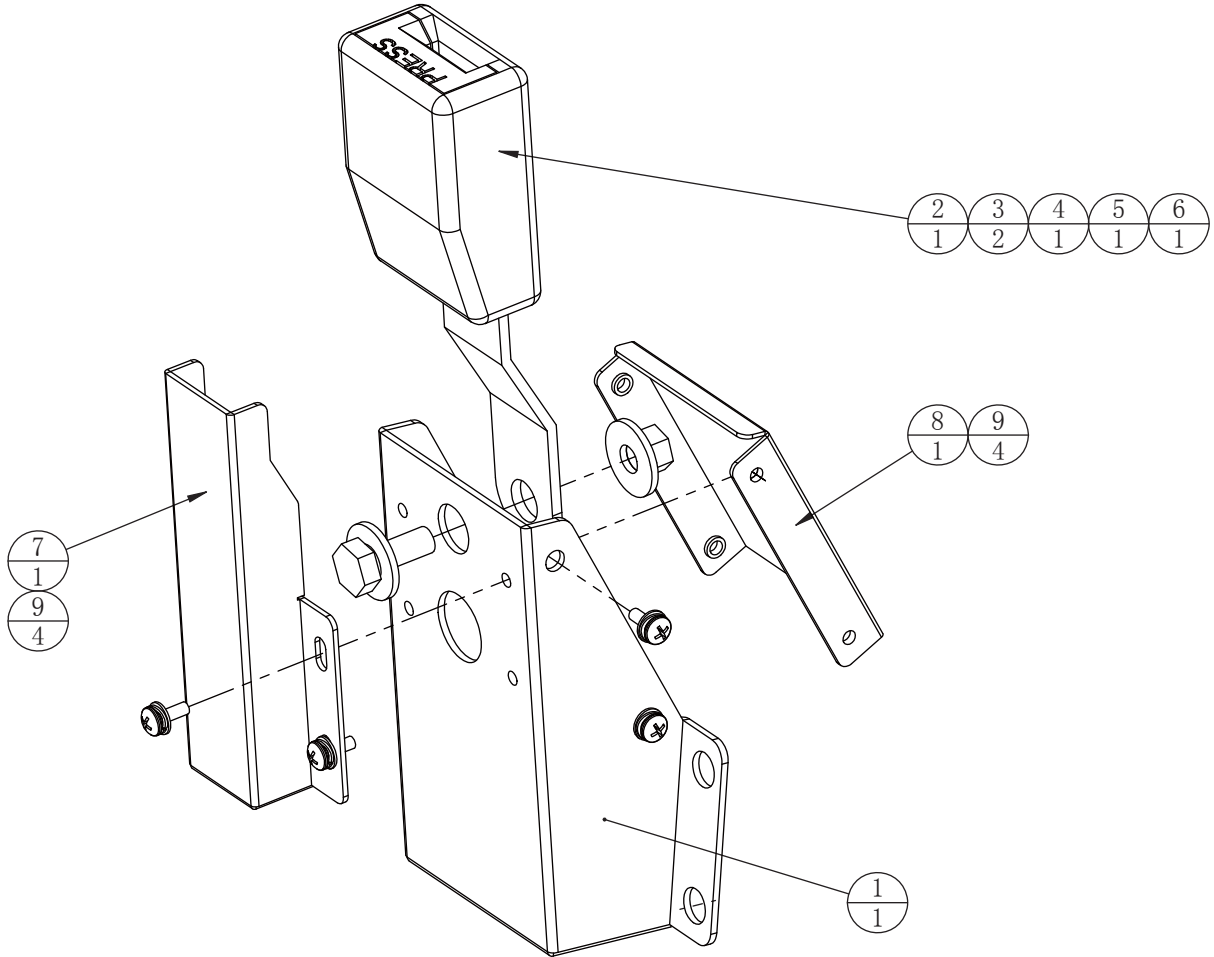

9	SRH-0302A03	Cross head three screws	M4*8 (Black)	8	1.6.LS840021
8	SRH-0302A02	Safety belt cover plate 2	SPCC-1.2T	1	1.1.WA16C00880
7		Safety belt cover plate 1	SPCC-1.5T	1	1.6.LM308014
6		Self-locking nut	M8 (Galvanization)	1	1.6.LM308014
5		External hex socket screw	M8*20 (Black)	1	1.6.LSM82011
4		Spring washer	M8 (Black)	1	1.6.DP208011
3		Flat washer	φ8*φ22*2.0 (Black)	2	1.6.DP108031
2		Seat belt		1	1.4.AQ000010
1	SRH-0302A01	Seat belt fixed iron	SPCC-2.0T	1	1.1.WA16C00530
No.	Draw No.	Name	Material/Spec.	Qty.	Product Code

6.5.3 Seat-belt roll-end assembly

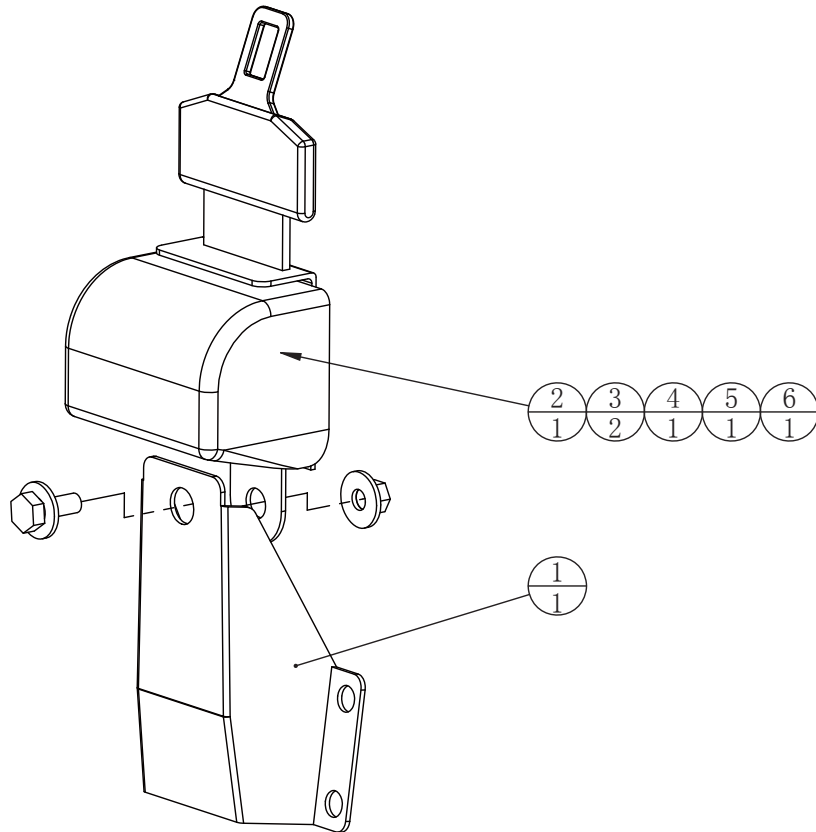

6		Self-locking nut	M8 (Galvanization)	1	1.6.LM308014
5		External hex socket screw	M8*20 (Black)	1	1.6.LSM82011
4		Spring washer	M8 (Black)	1	1.6.DP208011
3		Flat washer	φ8*φ22*2.0 (Black)	2	1.6.DP108031
2		Seat belt		1	1.4.AQ000010
1	SRH-0302A01	Seat belt fixed iron	SPCC-2.0T	1	1.1.WA16C00530
No.	Draw No.	Name	Material/Spec.	Qty.	Product Code

6.5.4 Vibrating speaker assembly

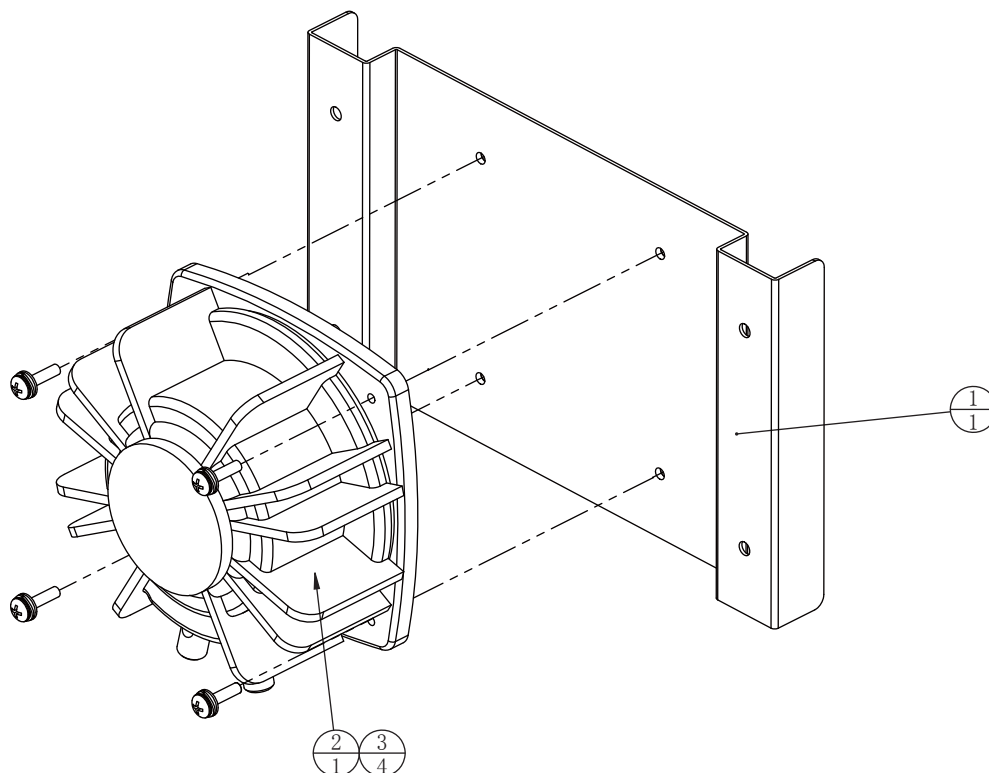

6		Hex socket flat head screw	M4*12 (chrome)	4	1.6.LS141022
5	SRH-P0001	Seat back acrylic 4	PMMA-5.0T	1	1.7.WA16C00120
4		5050 soft LED lamp panel of screen right and left	DC12V 60灯 L=150m	2	1.4.ZM9E0940
3		Turn signal lamp (without control box)	R-100/DC12V	1	1.4.ZM9H0010
2		Turn signal lamp (without control box)	R-100/DC12V	1	1.4.ZM9H0010
1	SRD-0500C01	Seat back cover	ABS-4.0T	1	1.8.WA16A030
No.	Draw No.	Name	Material/Spec.	Qty.	Product Code

6.6 Seat backrest assembly

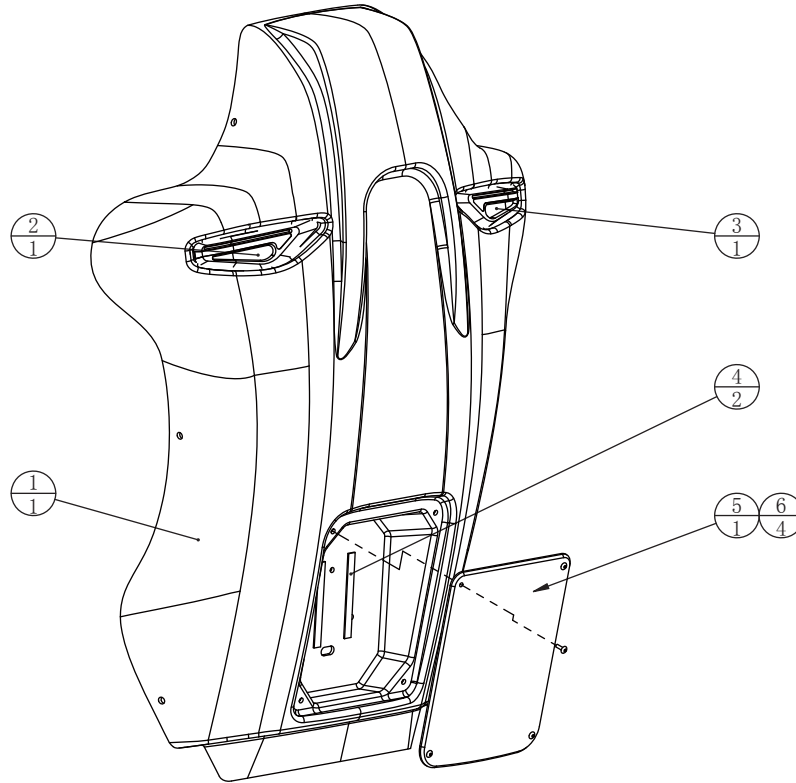

3		Cross recessed fillister head three-combination screw	M5*16 (Black)	4	1.6.LS851031
2		Low frequency vibrator	4Ω/50W	1	1.4.YSA00010
1	HXK-0501A01	Seat vibration speaker mounted plate	SPCC-1.5T	1	1.1.IG19A00660
No.	Draw No.	Name	Material/Spec.	Qty.	Product Code

6.7 Light-box assembly

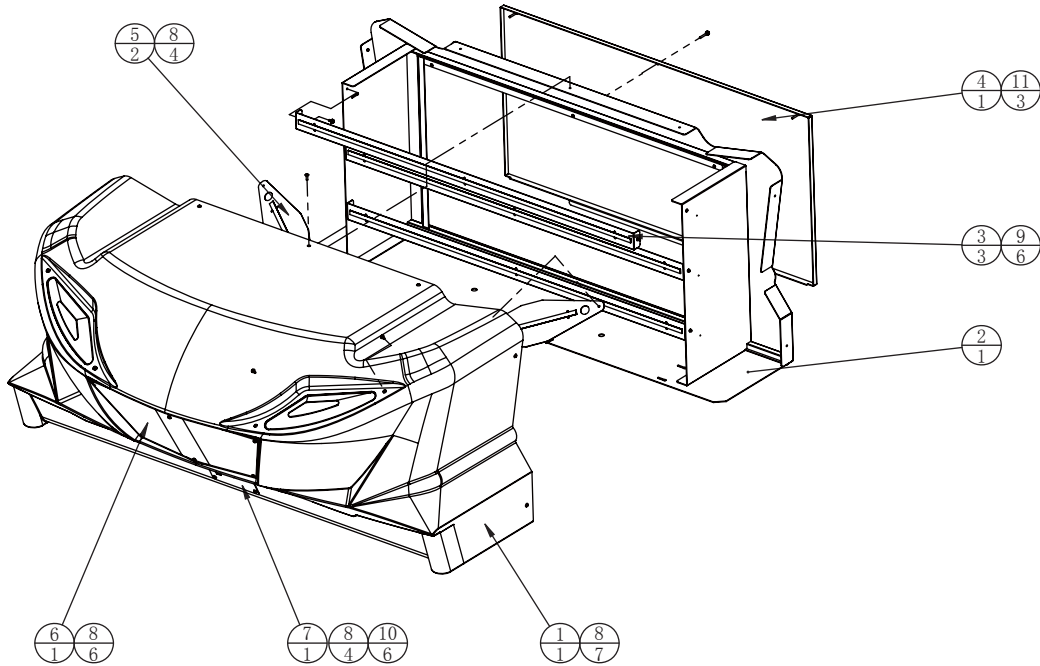

11		Cross recessed fillister head three-combination screw	M4*25 (Black)	3	1.6.LS84201
10		Hexagon nut with flange	M4 (Colour)	6	1.6.LM204013
9		Cross recessed fillister head three-combination screw	M4*8 (Black)	6	1.6.LS840021
8		Hex socket flat head screw	M4*12 (chrome)	21	1.6.LS141022
7	SRH-0503000	Camera assembly		1	
6	SRH-P0002	Signboard lamp box acrylic - chinese	PMMA-3.0T	1	1.7.WA16C00130
5	SRH-0502000	Eye LED assembly		2	
4	SRH-0500A02	Signboard back door	SPCC-1.5T	1	1.1.WA16C00550
3	SRH-0501000	Light-box LED assembly		3	
2	SRH-0500A01	Signboard hardware		1	1.1.WA16C00540
1	SRD-0800C01	Signboard lamp box		1	1.8.WA16A040
No.	Draw No.	Name	Material/Spec.	Qty.	Product Code

6.7.1 Light-box LED assembly

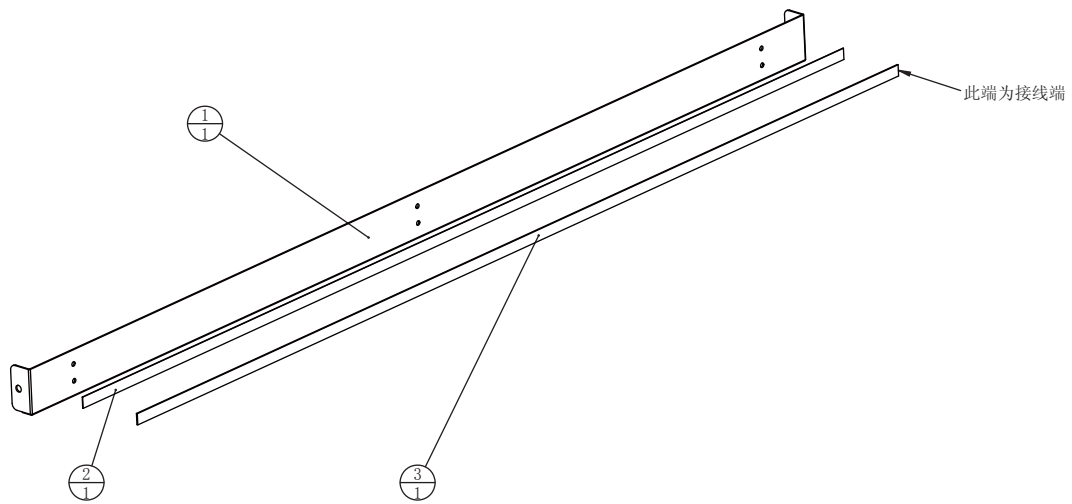

3		5050 soft LED lamp panel of screen right and left	DC12V 60 L=950mm	1	1.4.ZM9E0970
2	SRH-0501D01	Signboard lamp box PVC	PVC-0.5T	1	1.7.WA16C00060
1	SRH-0501A01	Lamp panel fixed iron	SPCC-1.2T	1	1.1.WA16C00560
No.	Draw No.	Name	Material/Spec.	Qty.	Product Code

6.7.2 Eye LED assembly

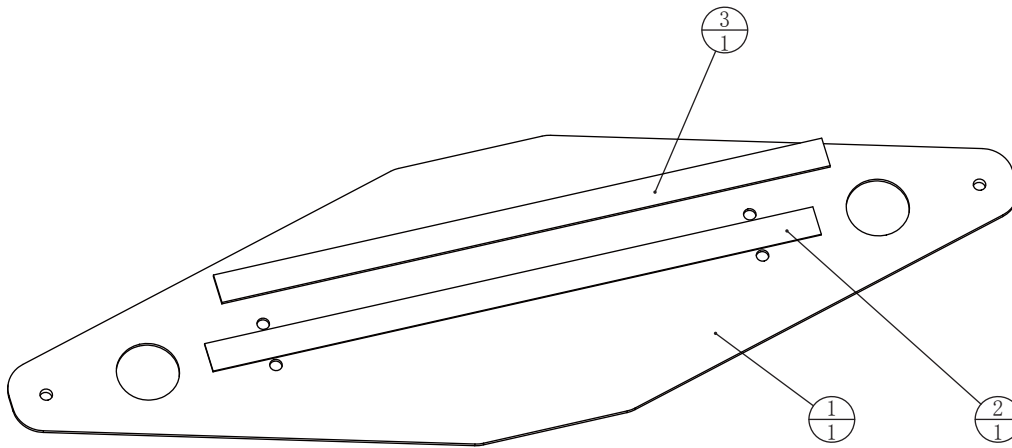

3		5050 soft LED lamp panel of screen right and left	DC12V RGB60灯	1	1.4.ZM9E0500
2	SRH-0502D01	Signboard lamp PVC	PVC-0.5T	1	1.7.WA16C00070
1	SRH-0502A01	Signboard lamp fixed iron	SPCC-1.2T	1	1.1.WA16C00570
No.	Draw No.	Name	Material/Spec.	Qty.	Product Code

6.8 Coin-acceptor assembly

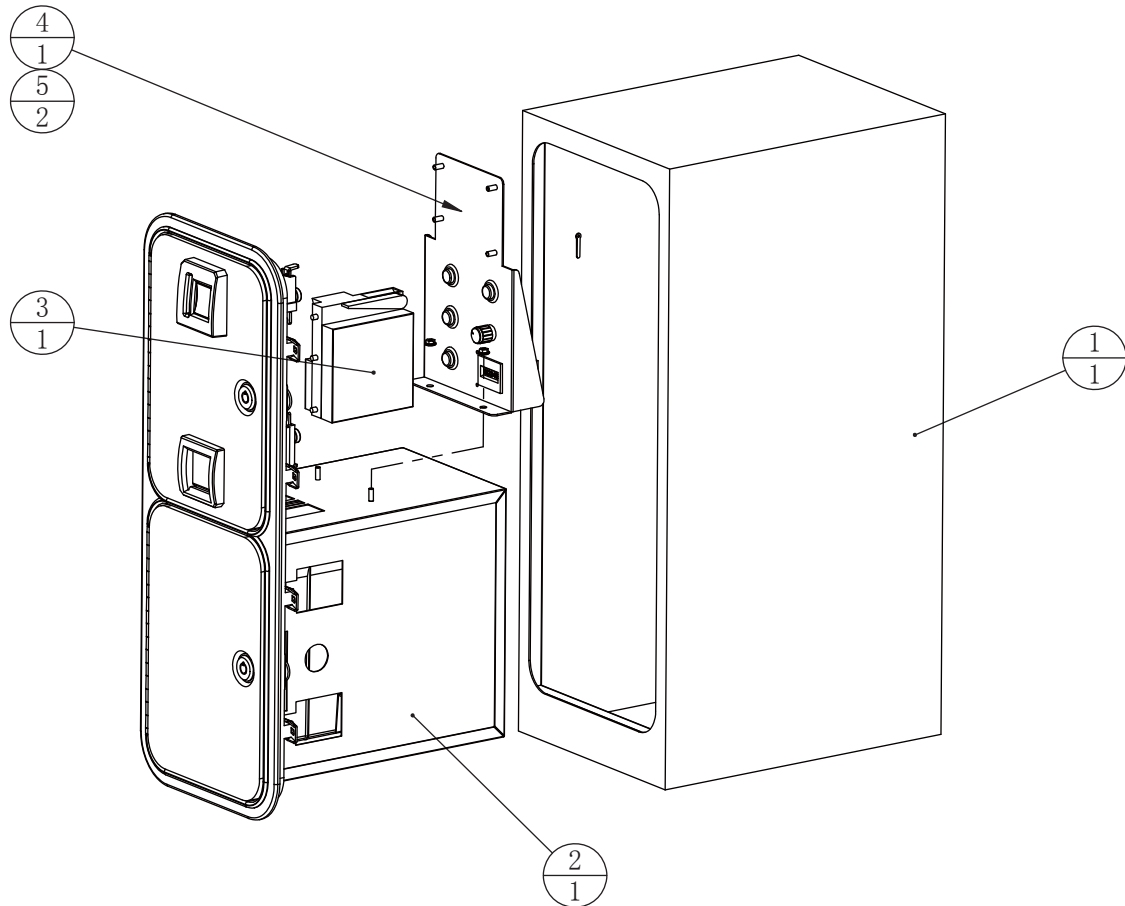

5			M4(colour)	2	1.6LM204013
4	SRH-0601000			1	
3			TW-800III	1	1.4TB100020
2	TYM-0000000A			1	2.1.AA030012
1	SRH-0600A01			1	1.1WA16C00590
NO.	Draw NO.	Name	Material/Spec.	Qty.	Product Code

6.8.1 Service-board components

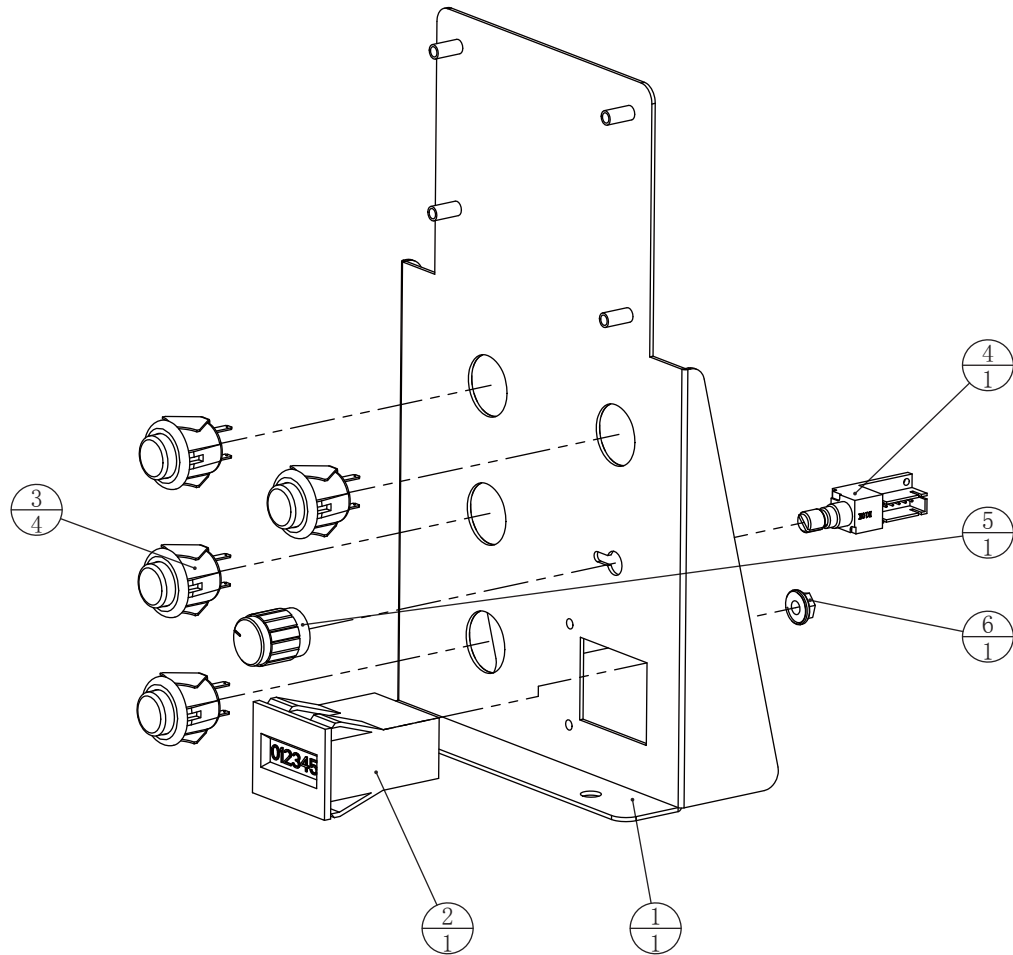

6		Hexagon nut with flange	M4 (Colour)	1	1.6.LM204013
5		Potentiometer knob	Φ13mm	1	1.4.VR201310
4		Volume VR components	VR-B10KΩ	1	1.4.VR160010
3		Round push button	SDP-103C-22RB	4	1.4.AJ500012#
2		Counter	DC 5V	1	1.4.JS100010
1	SRH-0601A01	Service button plate	SPCC-1.2T	1	1.1.WA16C00600
No.	Draw No.	Name	Material/Spec.	Qty.	Product Code

6.9 Control panel assembly

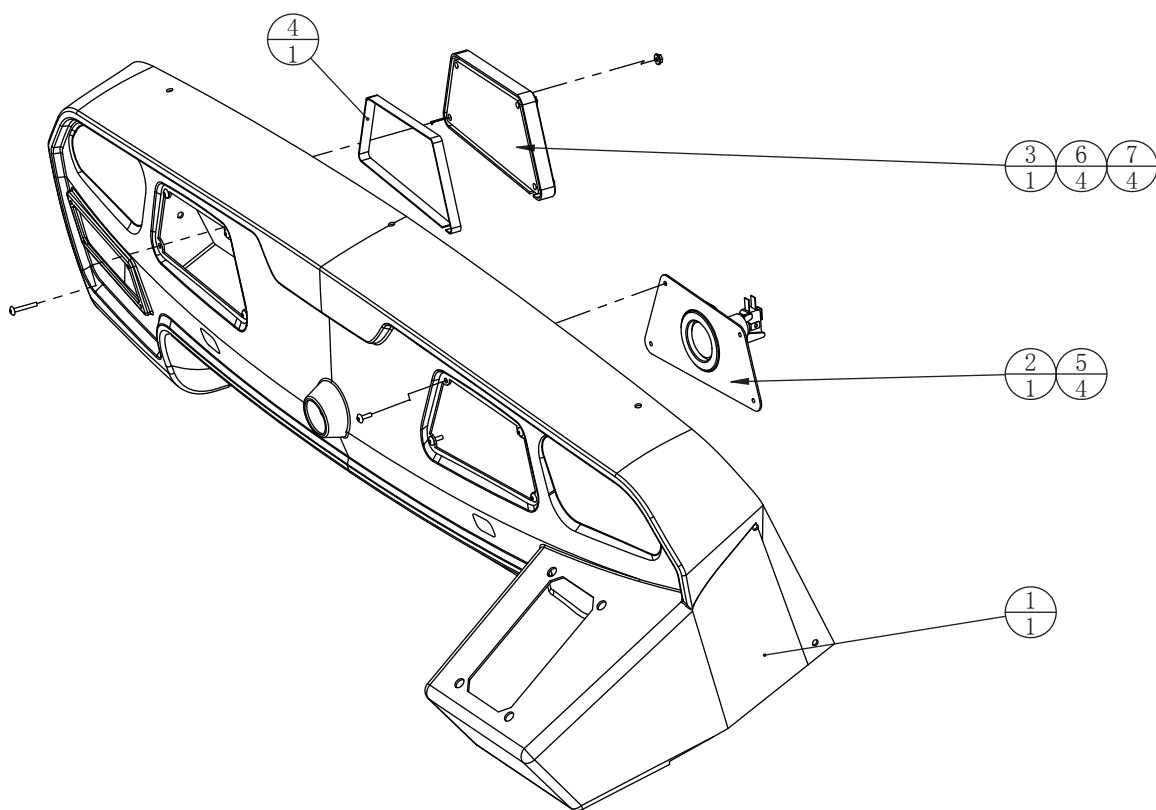

7		Hexagon nut with flange	M4 (Colour)	4	1.6.LM204013
6		Hex socket flat head screw	M4*25 (chrome)	4	1.6.LS142022
5		Hex socket flat head screw	M4*12 (chrome)	4	1.6.LS141022
4		5050 soft LED lamp panel of screen right and left	DC12V 60 L=450mm	1	1.4.ZM9E0930
3	SRH-P0003	Control panel acrylic	PMMA-15.0T	1	1.7.WA16C00140
2	SRH-0701000	Emergency-stop button assembly		1	
1	SRD-1300C01	Control panel plastic	ABS-2.0T	1	1.8.WA16A080
No.	Draw No.	Name	Material/Spec.	Qty.	Product Code

6.9.1 Emergency-stop button assembly

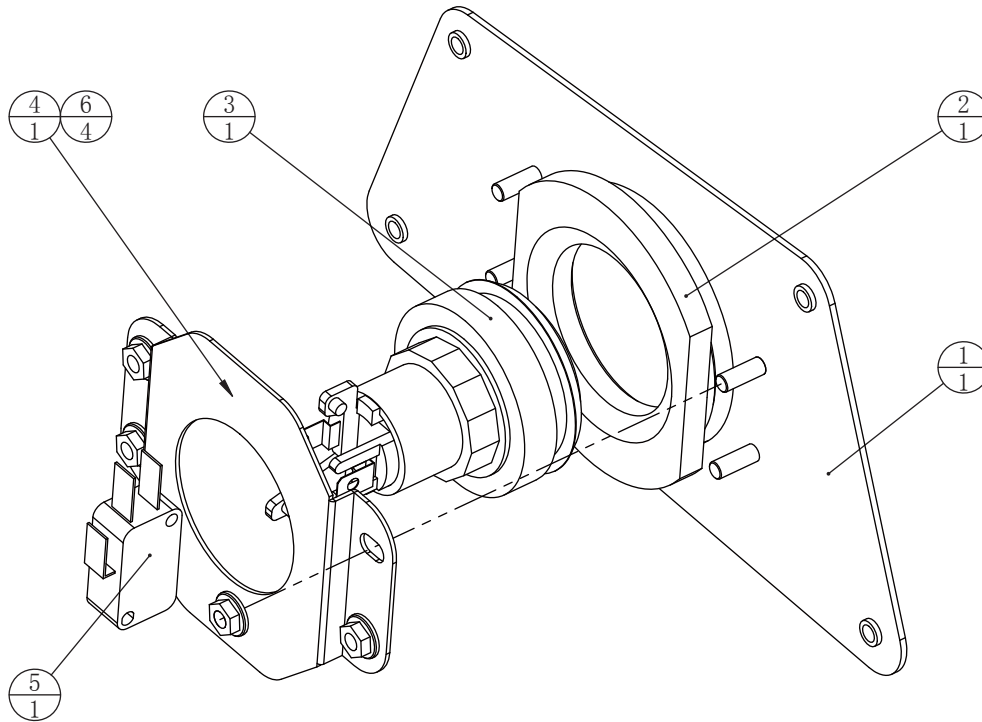

6		Hexagon nut with flange	M4 (Colour)	4	1.6.LM204013
5		Micro switch without plate	3P MN3-0300DB	1	1.4.SW103010
4	ME-1000A02	Control panel button fixed iron	SPCC-1.0T	1	1.1.IG22B01010
3		Round push button with lamp	Φ44 BLC-TN- BK-B-CW	1	1.1.IG22B00210
2	ME-1000D01	control panel button cover	PMMA-8.0T	1	1.7.IG22B00210
1	SRH-0701A01	Stop button mounted iron	SPCC-1.5T	1	1.1.WA16C00610
No.	Draw No.	Name	Material/Spec.	Qty.	Product Code

6.10 Start button assembly

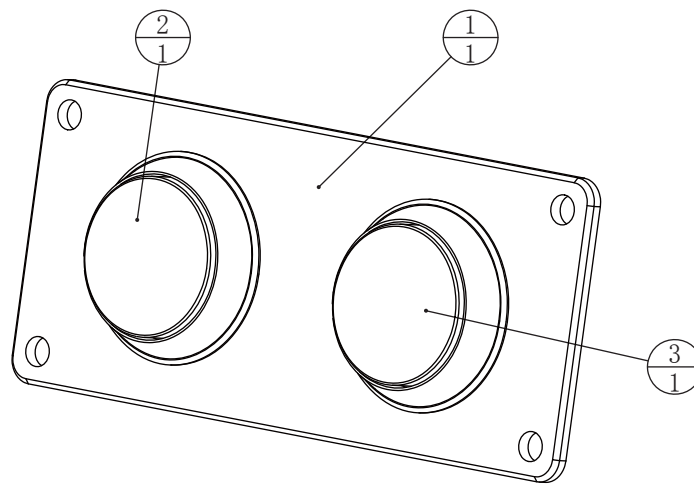

3		Round push button with lamp - blue	WLP-002	1	1.4.AJ130013#
2		Round push button with lamp - red	WLP-001	1	1.4.AJ130012#
1	SRH-0800D01	Push button acrylic	PMMA-3.0T	1	1.7.WA16C00080
No.	Draw No.	Name	Material/Spec.	Qty.	Product Code

6.11 Pedal component assembly

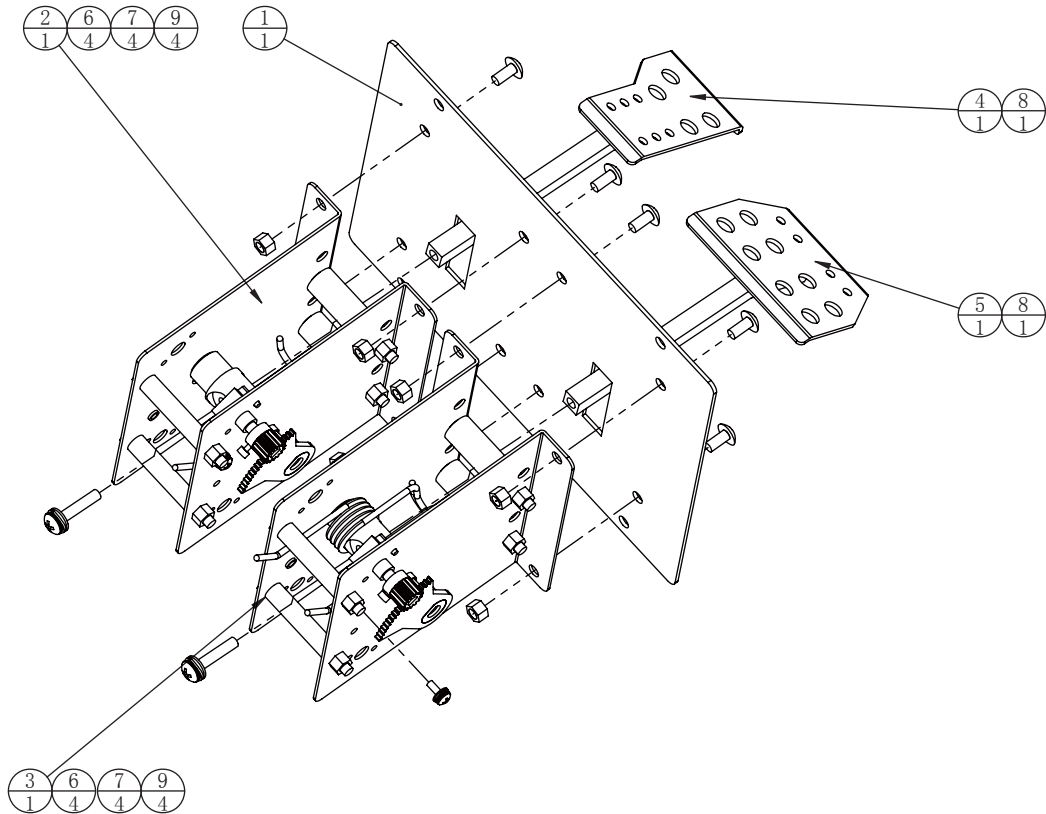

9		Cross recessed fillister head three-combination screw	M4*8 (Black)	2	1.6.LS840021
8		Cross recessed fillister head three-combination screw	M6*25 (Black)	2	*1.6.LS862021
7		Self-locking nut	M6 (Galvanization)	8	1.6.LM306014#
6		Cross recessed flat head screw	M6*12 (Black)	8	1.6.LS261021
5	SRH-0900A03	Accelerator component assembly		1	
4	SRH-0900A02	Brake-component assembly		1	
3	SRH-0902000	Brake-component assembly		1	
2	SRH-0901000	Accelerator component assembly		1	
1	SRH-0900A01		SPCC-2.0T	1	
No.	Draw No.	Name	Material/Spec.	Qty.	Product Code

6.11.1 Accelerator component assembly

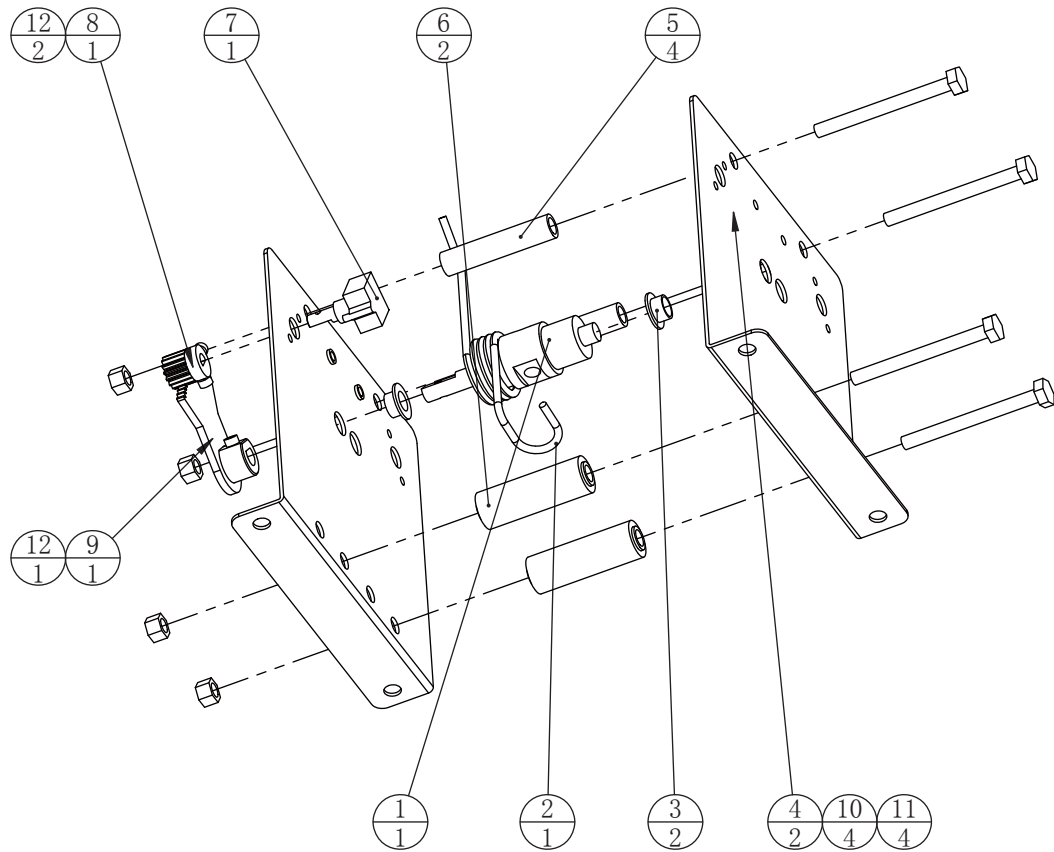

12		Hex socket fillister head screw	M3*8 (chrome)	3	1.6.LSF30012
11		Self-locking nut	M6 (Galvanization)	4	1.6.LM306014#
10		External hex socket screw	M6*60 (Black)	4	
9	SRH-0901A04			1	
8	SRH-0901A06		Q235	1	
7			308509090340110	1	
6	SRH-0901C02			2	
5	SRH-0901A05		Q235	4	
4	SRH-0901A03		SECC-1.5T	2	
3	SRH-0901C01		POM	2	
2	SRH-0901A02		65Mn	1	
1	SRH-0901A01		Q235	1	
No.	Draw No.	Name	Material/Spec.	Qty.	Product Code

6.11.2 Brake-component assembly

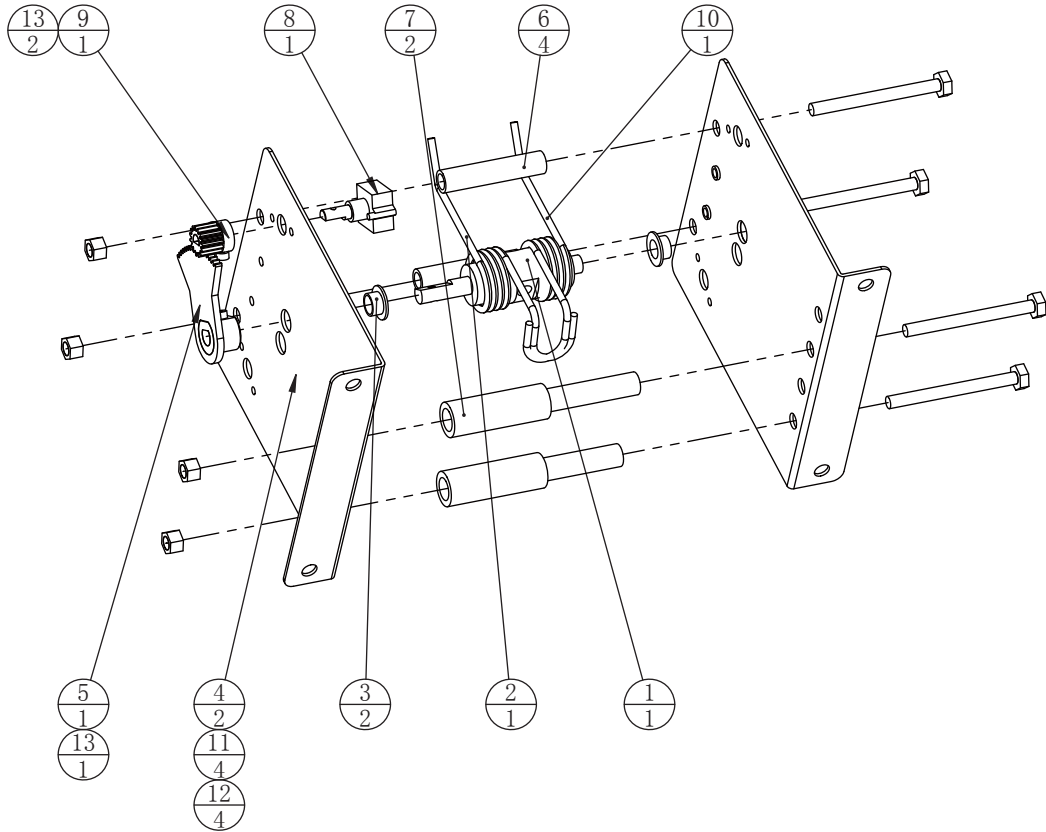

13		Hex socket fillister head screw	M3*8 (chrome)	3	1.6.LSF30012
12		Self-locking nut	M6 (Galvanization)	4	1.6.LM306014#
11		External hex socket screw	M6*60 (Black)	4	
10	SRH-0902A01		65Mn	1	
9	SRH-0901A06		Q235	1	
8			308509090340110	1	
7	SRH-0901C02			2	
6	SRH-0901A05		Q235	4	
5	SRH-0901A04			1	
4	SRH-0901A03		SECC-1.5T	2	
3	SRH-0901C01		POM	2	
2	SRH-0901A02		65Mn	1	
1	SRH-0901A01		Q235	1	
No.	Draw No.	Name	Material/Spec.	Qty.	Product Code

6.12 Rear-plastic assembly

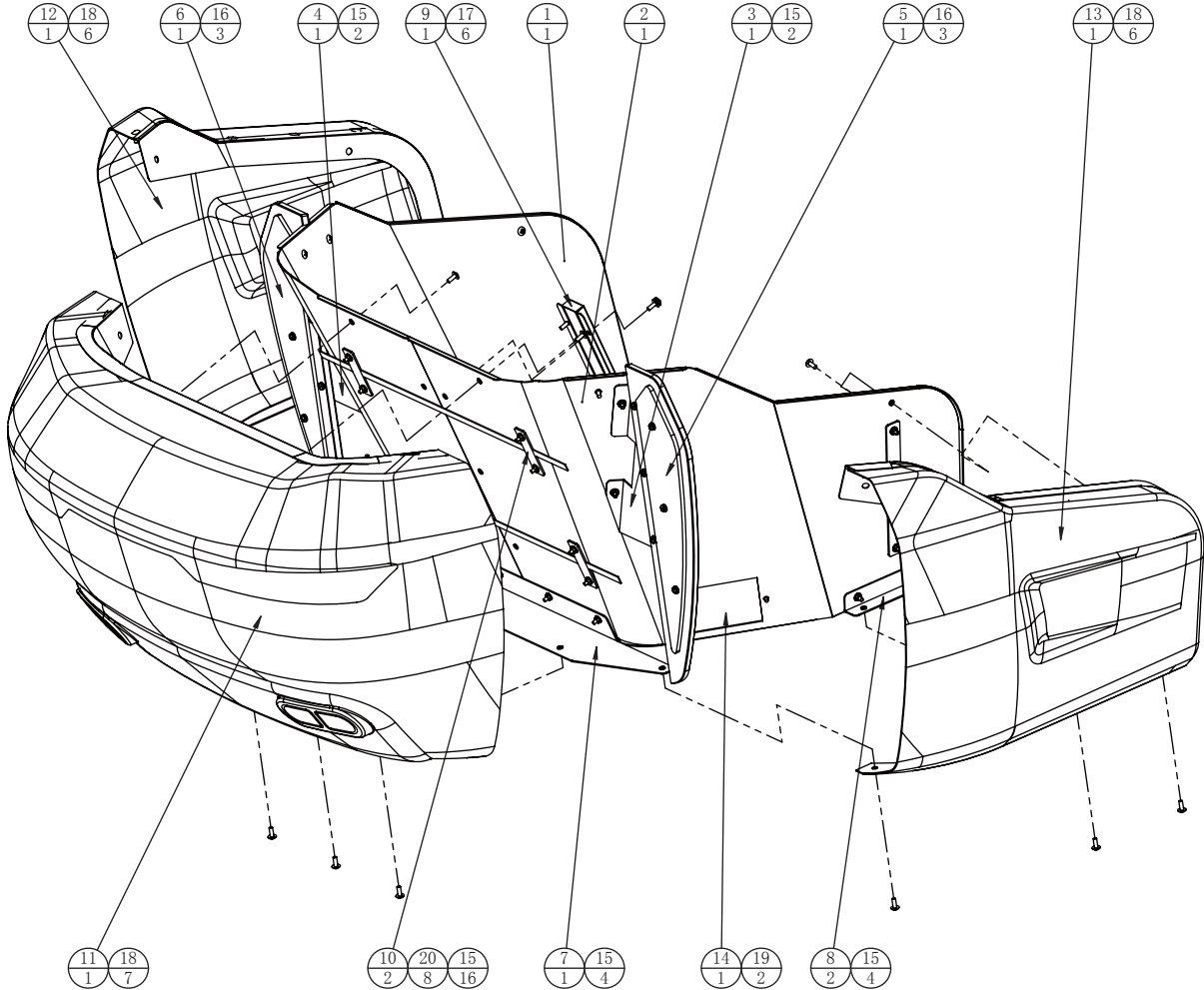

20	SRH-1000D01	The rear platen belt	PMMA-2.0T	8	1.7.WA16D00330
19		Cross recessed fillister head three-combination screw	M4*8 (Black)	2	1.6.LS840021
18		Cross recessed flat head screw	M5*12 (Black)	19	1.6.LS251021
17		Cross recessed fillister head three-combination screw	M5*12 (Black)	6	1.6.LS851021
16		Cross recessed fillister head three-combination screw	M4*16 (Black)	6	1.6.LS841031
15		Hexagon nut with flange	M4 (Colour)	28	1.6.LM204013
14	SRH-1000A08	Connectors cover plate	SPCC-1.0T	1	1.1.WA16C00690
13	SRH-1005000	Rear-side plastic (2) assembly		1	
12	SRH-1004000	Rear-side plastic (1) assembly		1	
11	SRH-1003000	Rear-plastic assembly		1	
10		5050 soft LED lamp panel of screen right and left	DC12V 60 L=1350mm	2	1.4.ZM9E0950
9	SRH-1000A07	Tail connecting iron	SPCC-1.0T	1	1.1.WA16C00680
8	SRH-1000A06	Tail plastic fixed iron 2	SPCC-1.5T	2	1.1.WA16C00670
7	SRH-1000A05	Tail plastic fixed iron 1	SPCC-1.5T	1	1.1.WA16C00660
6	SRH-1002000	Tail acryl 2 assembly		1	
5	SRH-1001000	Tail acryl 1 assembly		1	
4	SRH-1000A04	Tail plastic support iron 4	SPCC-1.5T	1	1.1.WA16C00650
3	SRH-1000A03	Tail plastic support iron 3	SPCC-1.5T	1	1.1.WA16C00640
2	SRH-1000A02	Tail plastic support iron 2	SPCC-1.5T	1	1.1.WA16C00630
1	SRH-1000A01	Tail plastic support iron 1	SPCC-1.5T	1	1.1.WA16C00620
No.	Draw No.	Name	Material/Spec.	Qty.	Product Code

6.12.1 Tail acryl 1 assembly

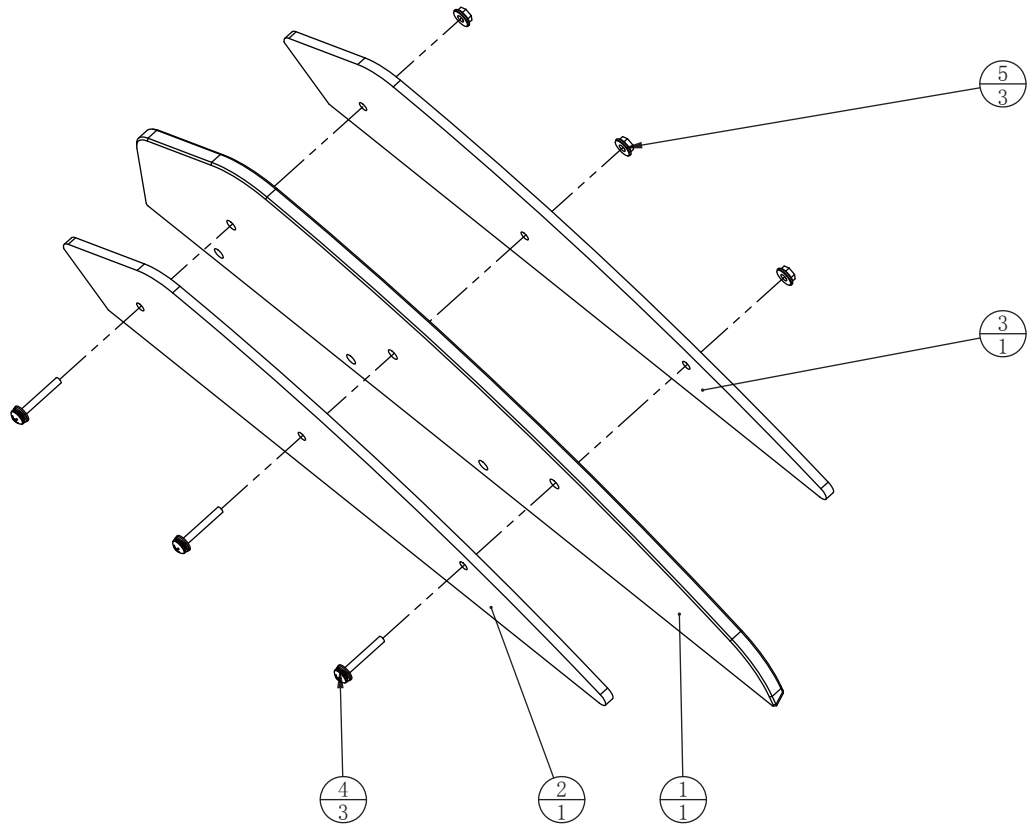

5		Hexagon nut with flange	M4 (Colour)	3	1.6.LM204013
4		Cross recessed fillister head three-combination screw	M4*25 (Black)	3	1.6.LS842021
3	SRH-1001D03	Seat back acrylic 3	PMMA-5.0T	1	1.7.WA16C00110
2	SRH-1001D02	Seat back acrylic 2	PMMA-5.0T	1	1.7.WA16C00100
1	SRH-1001D01	Seat back acrylic 1	PMMA-8.0T	1	1.7.WA16C00090
No.	Draw No.	Name	Material/Spec.	Qty.	Product Code

6.12.2 Tail acryl 2 assembly

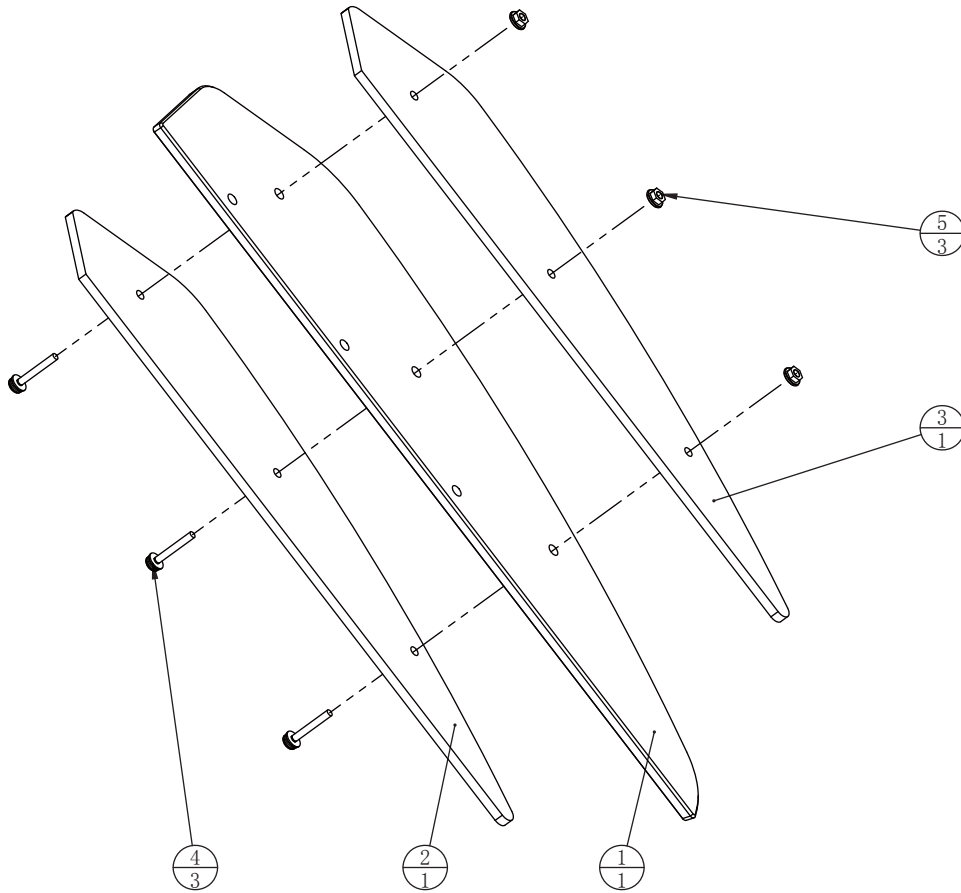

5		Hexagon nut with flange	M4 (Colour)	3	1.6.LM204013
4		Cross recessed fillister head three-combination screw	M4*25 (Black)	3	1.6.LS842021
3	SRH-1001D03	Seat back acrylic 3	PMMA-5,0T	1	1.7.WA16C00110
2	SRH-1001D02	Seat back acrylic 2	PMMA-5,0T	1	1.7.WA16C00100
1	SRH-1001D01	Seat back acrylic 1	PMMA-8,0T	1	1.7.WA16C00090
No.	Draw No.	Name	Material/Spec.	Qty.	Product Code

6.12.3 Rear-plastic assembly

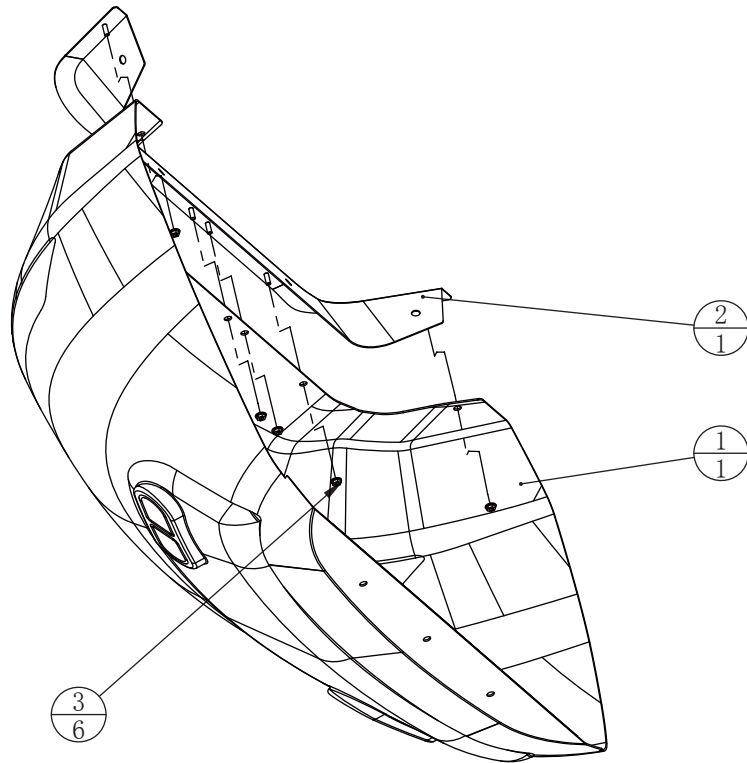

3		Hexagon nut with flange	M4 (Colour)	6	1.6.LM204013
2	SRH-1003A01	Tail plastic pressure iron 1	SPCC-1.0T	1	1.1.WA16C00700
1	SRD-1000C01	Seat back plastic - middle	PMMA-3.0T	1	1.8.WA16A050
No.	Draw No.	Name	Material/Spec.	Qty.	Product Code

6.12.4 Rear-side plastic (1) assembly

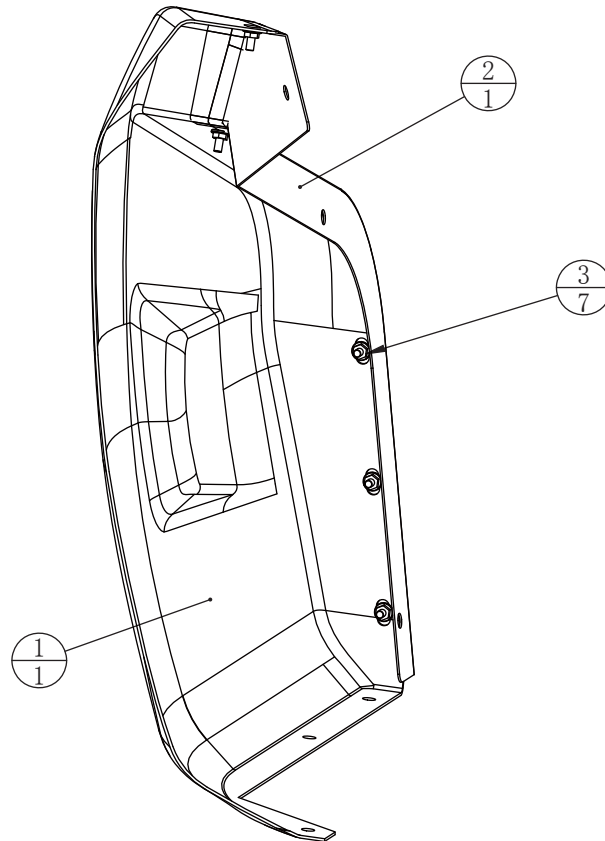

3		Hexagon nut with flange	M4 (Colour)	7	1.6.LM204013
2	SRH-1004A01	Tail plastic pressure iron 2	SPCC-1.0T	1	1.1.WA16C00710
1	SRD-1100C01	Seat back plastic - left	PMMA-3.0T	1	1.8.WA16A060
No.	Draw No.	Name	Material/Spec.	Qty.	Product Code

6.12.5 Rear-side plastic (2) assembly

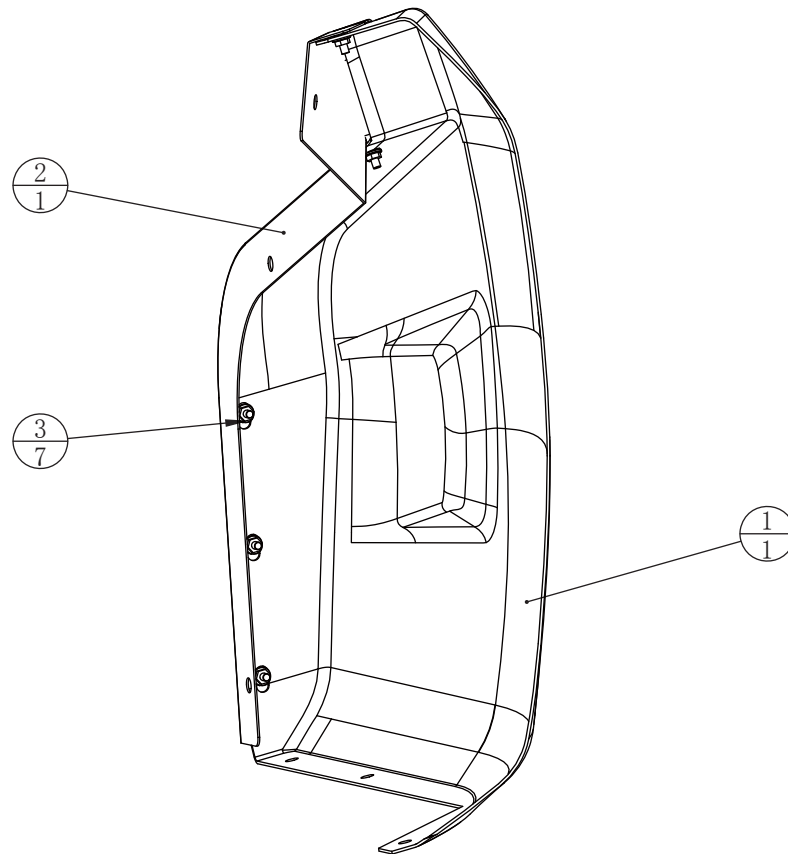

3		Hexagon nut with flange	M4 (Colour)	7	1.6.LM204013
2	SRH-1005A01	Tail plastic pressure iron 3	SPCC-1.0T	1	1.1.WA16C00720
1	SRD-1200C01	Seat back plastic - right	PMMA- 3.0T	1	1.8.WA16A070
No.	Draw No.	Name	Material/Spec.	Qty.	Product Code

6.13 Back-door assembly

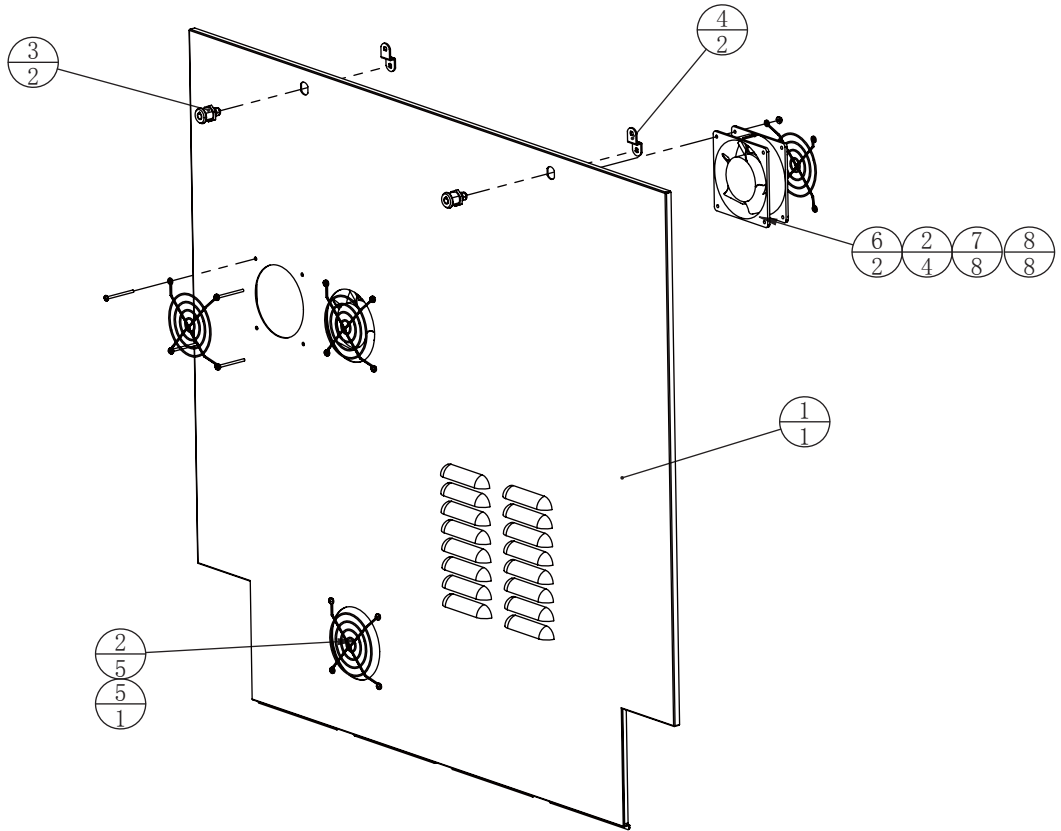

8		Hexagon nut with flange	M4 (Colour)	8	1.6.LM204013
7		Cross recessed fillister head screw	M4*50 (chrome)	8	1.6.LS745012
6		Fan with bearing	120*120/AC110V	2	1.4.FS200042
5		Cross recessed flat head screw	M4*12 (chrome)	4	1.6.LS241022
4		cam lock plate - bent	(NO. 002)	2	1.4.SJ500050
3		cam lock	5555-S	2	1.4.SJ120110
2		fan cover	120*120	5	1.4.FS300020
1	SRH-1100A01	Back door		1	1.1.WA16C00730
No.	Draw No.	Name	Material/Spec.	Qty.	Product Code

6.14 Steering-wheel assembly

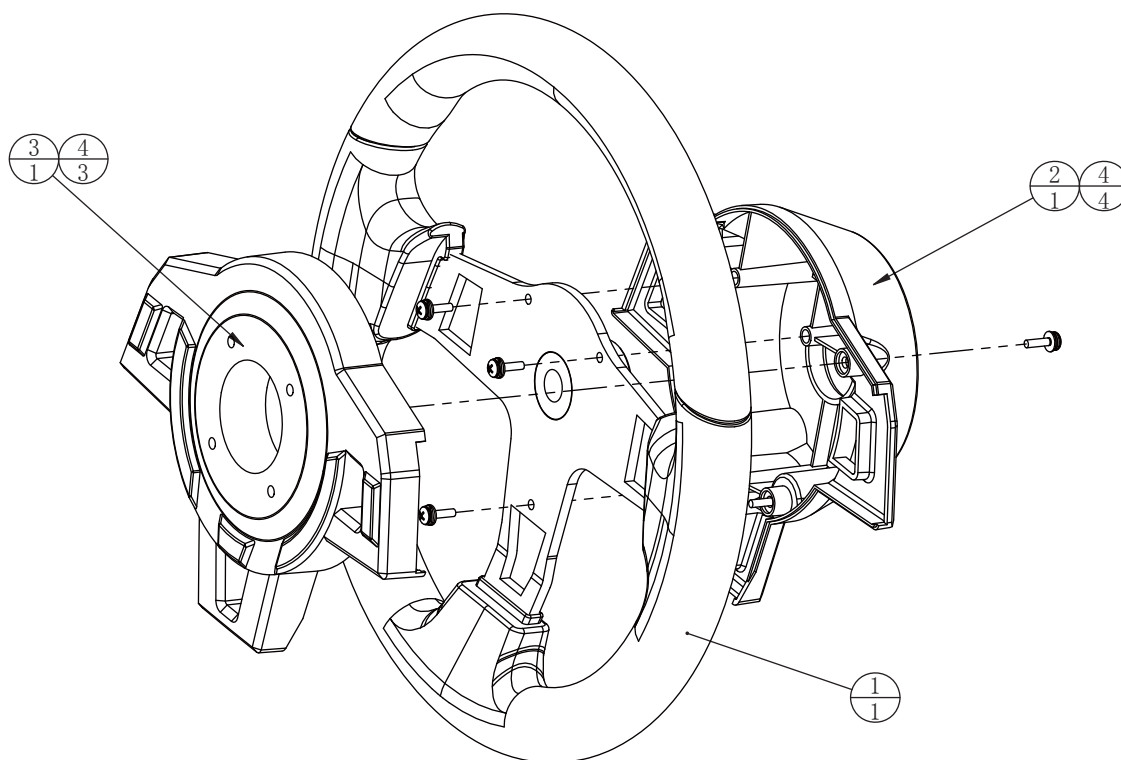

4		Cross recessed fillister head three-combination screw	M4*12 (Black)	7	1.6.LS841021
3	SR1-1300C01	Steering wheel upper cover	ABS	1	1.8.WA10A070
2	SR1-1300C02	Steering wheel lower cover	ABS	1	1.8.WA10A080
1	SR1-1300A01	Steering wheel		1	1.1.WA10A00490
No.	Draw No.	Name	Material/Spec.	Qty.	Product Code

7. Printing Pattern



8. Wiring Diagram

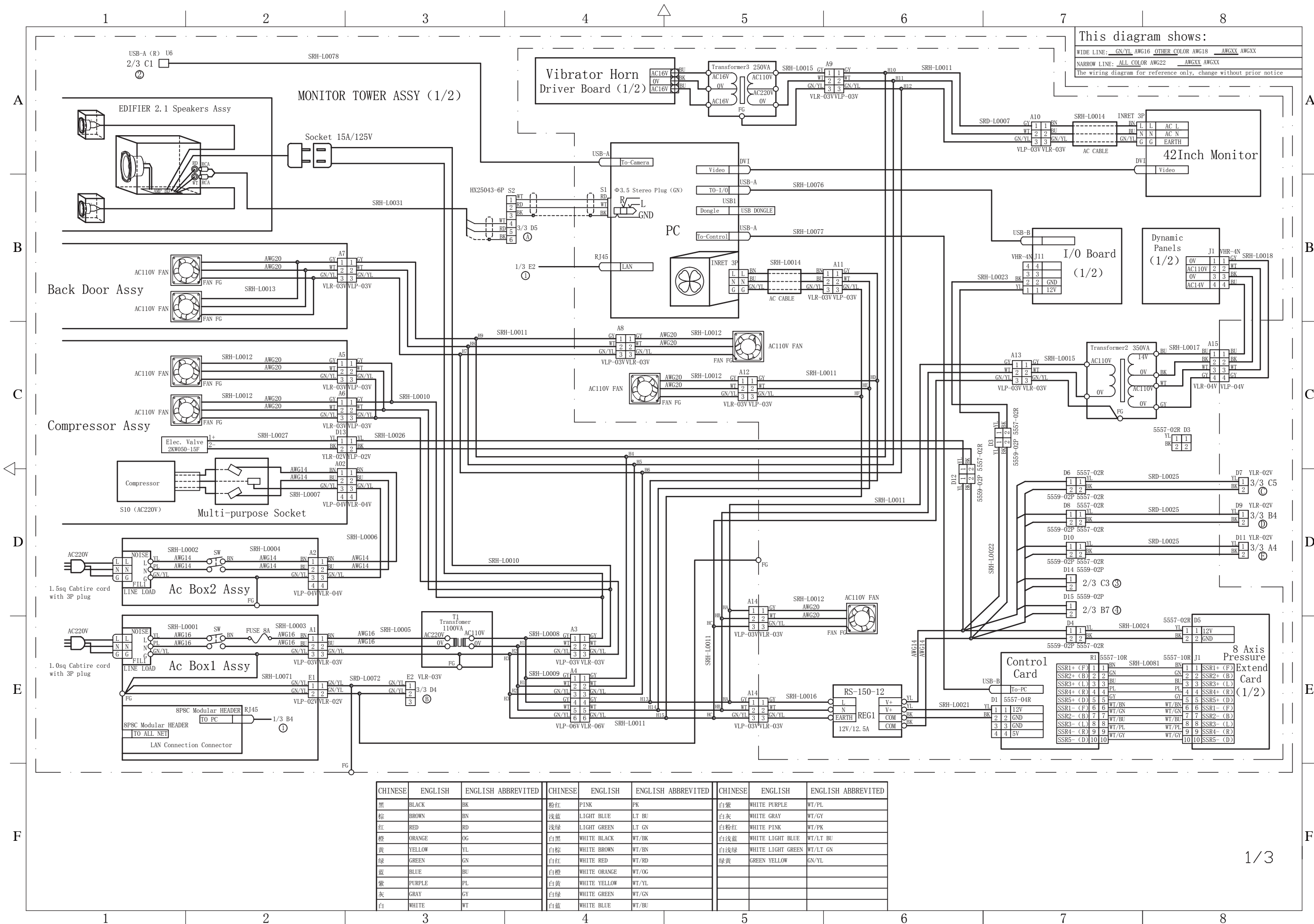

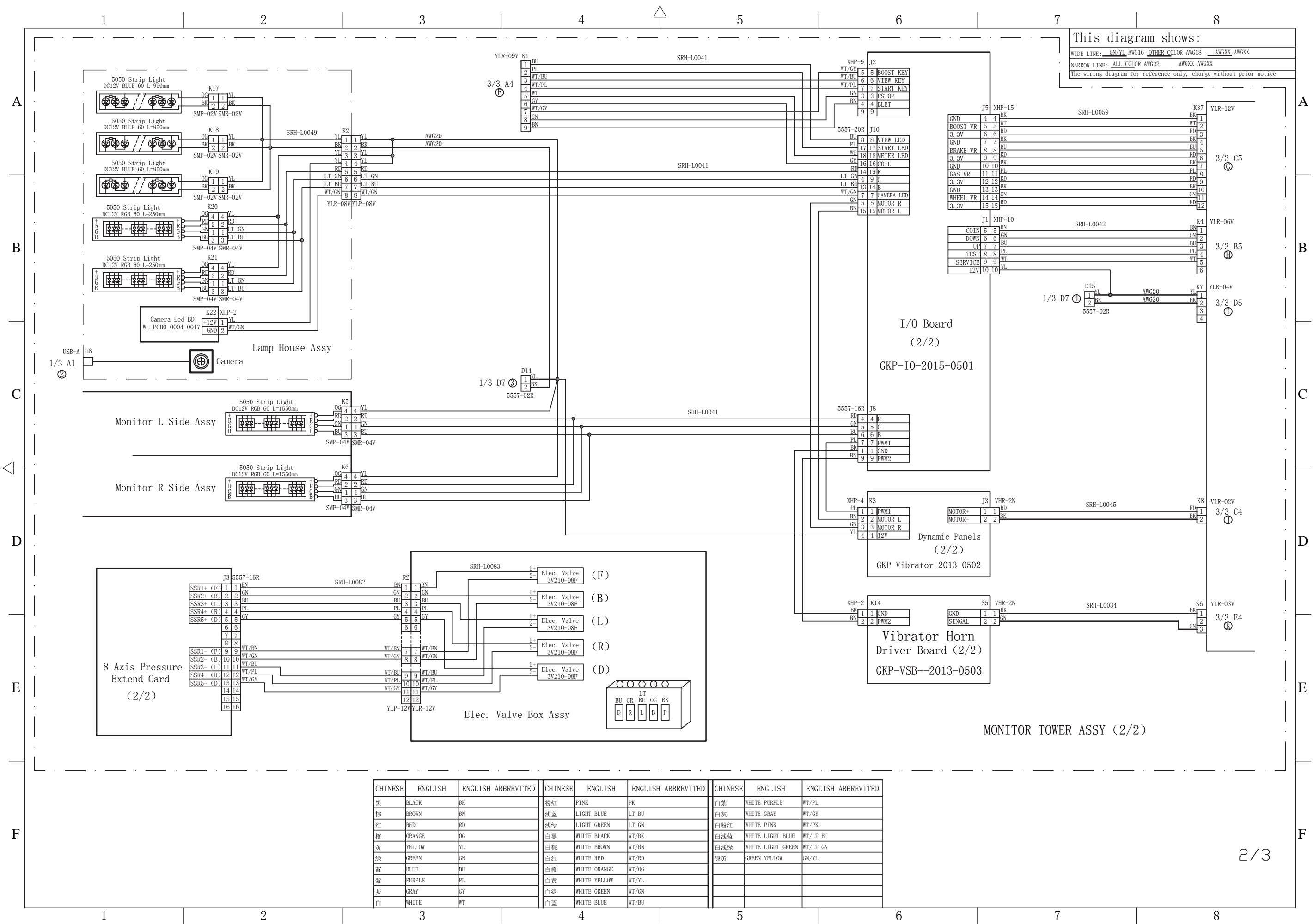

This diagram shows:
 WIDE LINE: GN/YL, AWG16, OTHER COLOR AWG18, AWGXX, AWGXX
 NARROW LINE: ALL COLOR AWG22, AWGXX, AWGXX
 The wiring diagram for reference only, change without prior notice

CHINESE	ENGLISH	ENGLISH ABBREVIATED	CHINESE	ENGLISH	ENGLISH ABBREVIATED	CHINESE	ENGLISH	ENGLISH ABBREVIATED
黑	BLACK	BK	粉红	PINK	PK	白紫	WHITE PURPLE	WT/PL
棕	BROWN	BN	浅蓝	LIGHT BLUE	LT BU	白灰	WHITE GRAY	WT/GY
红	RED	RD	浅绿	LIGHT GREEN	LT GN	白粉红	WHITE PINK	WT/PK
橙	ORANGE	OG	白黑	WHITE BLACK	WT/BK	白浅蓝	WHITE LIGHT BLUE	WT/LT BU
黄	YELLOW	YL	白棕	WHITE BROWN	WT/BN	白浅绿	WHITE LIGHT GREEN	WT/LT GN
绿	GREEN	GN	白红	WHITE RED	WT/RD	绿黄	GREEN YELLOW	GN/YL
蓝	BLUE	BU	白橙	WHITE ORANGE	WT/OG			
紫	PURPLE	PL	白黄	WHITE YELLOW	WT/YL			
灰	GRAY	GY	白绿	WHITE GREEN	WT/GN			
白	WHITE	WT	白蓝	WHITE BLUE	WT/BU			

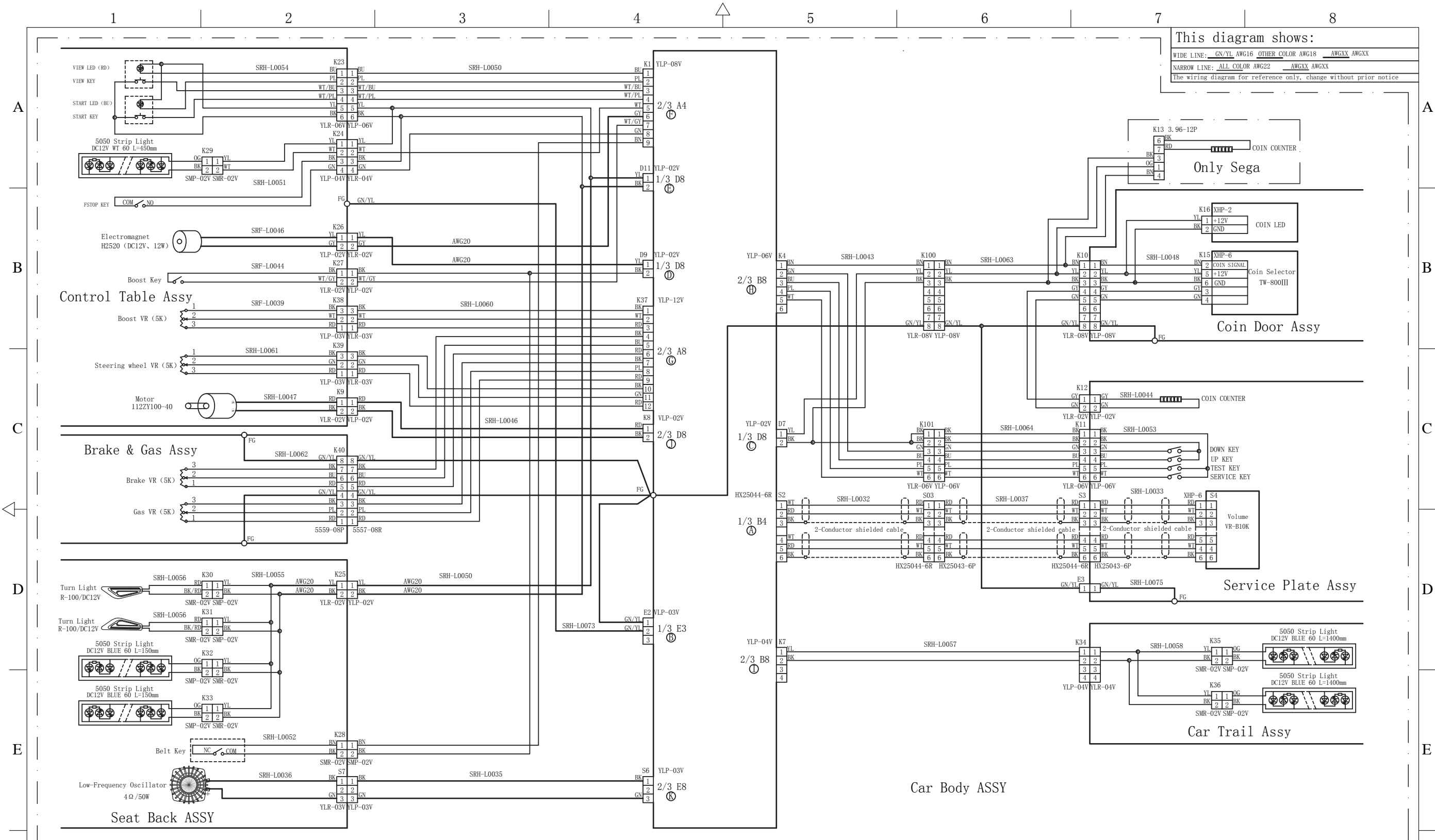

CHINESE	ENGLISH	ENGLISH ABBREVIATED	CHINESE	ENGLISH	ENGLISH ABBREVIATED	CHINESE	ENGLISH	ENGLISH ABBREVIATED
黑	BLACK	BK	粉红	PINK	PK	白紫	WHITE PURPLE	WT/PL
棕	BROWN	BN	浅蓝	LIGHT BLUE	LT BU	白灰	WHITE GRAY	WT/GY
红	RED	RD	浅绿	LIGHT GREEN	LT GN	白粉红	WHITE PINK	WT/PK
橙	ORANGE	OG	白黑	WHITE BLACK	WT/BK	白浅蓝	WHITE LIGHT BLUE	WT/LT BU
黄	YELLOW	YL	白棕	WHITE BROWN	WT/BN	白浅绿	WHITE LIGHT GREEN	WT/LT GN
绿	GREEN	GN	白红	WHITE RED	WT/RD	绿黄	GREEN YELLOW	GN/YL
蓝	BLUE	BU	白橙	WHITE ORANGE	WT/OG			
紫	PURPLE	PL	白黄	WHITE YELLOW	WT/YL			
灰	GRAY	GY	白绿	WHITE GREEN	WT/GN			
白	WHITE	WT	白蓝	WHITE BLUE	WT/BU			

9. After-sales Service

Honorable customer !

Thank you for purchasing our product !

For your benefits, if you find any fault during the operation of the product, please use a technician who obtains a certificate related to mechanical engineering, electrical engineering or who engages in routine maintenance, repair and management of amusement machine to check the machine and inform us the fault in a timely manner. Our company will take corresponding measures to assist you to solve the problem promptly.

NOTICE: Do not dismount or replace any part of the machine without our technician's permission, or you will solely undertake the consequence !

Please pay attention to our contact information as follow:

GuangZhou Wahlap Technology Limited

Add: H1-H6 Startoon city, Yingxing Dong Road, Donghuan Street, Panyu, Guangzhou, China

Tel: +86 20 39226222 Fax: +86 20 39226300

Service Hotline: +86 20 39226222 4006-926-222

E-mail: sales@wahlap.com Postcode: 511490

<http://www.wahlap.com>

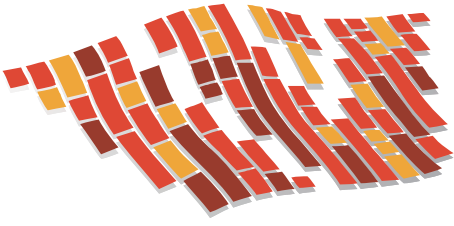

Ver.2.01

WAHLAP TECH
<http://www.wahlap.com.cn>

※ The specifications and operation instructions in this Manual are subject to change without notice for reasons such as performance.