

1st PRINTING
JULY 2018

SEGA®

Sega Amusements International Limited.
42 Barwell Business Park, Leatherhead Road, Chessington, Surrey, KT9 2NY. United Kingdom.
Telephone: +44 (0) 208 391 8090 Facsimile: +44 (0) 208 391 8099
mailbox@sega.co.uk segaarcade.com

Sega Games Co., Ltd.
1-2-12, Haneda, Ota-ku, Tokyo, 144-8531. Japan.
Telephone: +81-3-5736-7111 Facsimile: +81-3-6871-7672
sega-games.co.jp

© SEGA
Errors and omissions excepted (E&OE)

DAYTONA CHAMPIONSHIP USA

OWNER'S MANUAL

420-0028-05

SEGA®

OWNER'S MANUAL

DAYTONA®
CHAMPIONSHIP USA



IMPORTANT

- Before using this product, read this manual carefully to understand the contents herein stated.
- After reading this manual, be sure to keep it near the product or in a convenient place for easy reference when necessary.

Definition of 'Site Maintenance Personnel or Other Qualified Individuals

WARNING

Servicing and maintenance work of the contents herein stated should be performed by the **SERVICEMAN** stipulated as per IEC Standard. Those who do not have technical expertise and knowledge other than the **SERVICEMAN** are not allowed to perform the work herein stated. Executing aforementioned work by such non-technical personnel can cause serious accidents that may endanger life.

Parts replacement, maintenance inspections and troubleshooting should be carried out by site maintenance personnel or other qualified professionals. This manual includes directions for potentially dangerous procedures which should only be carried out by professionals with the appropriate specialised knowledge.

The site maintenance personnel or other qualified professionals mentioned in this manual are defined as follows:

Site maintenance personnel:

Individuals with experience in maintaining amusement equipment, vending machines, etc., working under the supervision of the owner/operator of this product to maintain machines within amusement facilities or similar premises by carrying out everyday procedures such as assembly, maintenance inspections, and replacement of units/expendable parts.

Activities to be carried out by site maintenance personnel:

Amusement equipment/vending machine assembly, maintenance inspection and replacement of units/expendable parts.

Other qualified professionals:

Persons employed by amusement equipment manufacturers, or involved in design, production, testing or maintenance of amusement equipment. The individual should have either graduated from technical school or hold similar qualifications in electrical/electronics/mechanical engineering.

Activities to be carried out by other qualified professionals:

Amusement equipment/vending machine assembly, repair/adjustment of electrical/electronic/mechanical parts.

SPECIFICATIONS

Installed Dimensions & Specifications per Cabinet

| | |
|---------------------|---|
| Machine Dimensions: | 1.07m (42.1in.) [Width] x 1.67m (65.7in.) [Depth] |
| Machine Height: | 2.25m (88.5in.) |
| Machine Weight: | 245kg Approx |

| | |
|-------------------|---------------|
| Installed Rating: | AC240V - 1.6A |
| | AC120V - 2.5A |
| | 313W |

Waste of Electrical and Electronic Equipment (WEEE) Statement

The WEEE (Waste of Electrical and Electronic Equipment) directive places an obligation on all EU based manufacturers and importers of Electrical and Electronic Equipment (EEE) to ensure waste equipment is disposed of in accordance with the directive at the end of their useful life.

The symbol shown below will be placed on all products manufactured from 13th August 2005, which indicates this product must NOT be disposed of with other normal waste. Upon purchasing any EEE from SEGA Amusements International Ltd. The user accepts responsibility to dispose of their waste equipment by arranging to return it to a designated UK collection point (AATF) or an Approved Exporter (AE) for the correct recycling of waste electrical and electronic equipment.

For more information on Approved Authorised Treatment Facilities (AATF) within the UK please consult the government website www.gov.uk

For users outside of the UK EEE should be disposed of in accordance with the local policy on the recycling of Waste Electrical and Electronic Equipment.

Battery Recycling Statement

The EC Directive on Batteries and Accumulators (2006/66/EC) aims to minimise the impact of batteries on the environment and encourage the recovery of the materials they contain. To achieve increased collection and recycling of waste batteries, the Directive places 'producer responsibility' obligations on manufacturers and importers of portable, industrial and automotive batteries.

The symbol shown below will be on all equipment fitted with batteries from 26th September 2008 and indicates they must NOT be disposed of with other normal waste. Instead, it is the user's responsibility to dispose of used batteries by arranging to return them to a designated collection point for the correct recycling.

For more information about where you can send your waste batteries for recycling, contact your local authority office.



REGISTERED IN ENGLAND REGISTERED NO. 1711515

REGISTERED OFFICE: BLOCK C 42 BARWELL BUSINESS PARK, CHESSINGTON, SURREY KT9 2NY

BEFORE USING THE PRODUCT, BE SURE TO READ THE FOLLOWING:

To maintain safety:

To ensure the safe operation of this product, be sure to read the following before usage:

The following instructions are intended for the users, operators and the personnel in charge of the operation of the product. After carefully reading and sufficiently understanding the warning displays and cautions, handle the product appropriately. Be sure to keep this manual close to the product or in a convenient place for future reference.

Herein, explanations which require special attention are enclosed with dual lines. Depending on the potentially hazardous degrees, the terms of DANGER, WARNING, CAUTION, etc. are used. Be sure to understand the contents of the displays before reading the text.

 **DANGER** Indicates that mishandling the product by disregarding this pictograph will cause severe injury or death.

 **WARNING** Indicates that mishandling the product by disregarding this warning will cause a potentially hazardous situation which can result in death or serious injury.

 **CAUTION** Indicates that mishandling the product by disregarding this caution will cause a slight hazardous situation which can result in personal injury and/or material damage.

For the safe usage of the product, the following pictographs are used:

 Indicates "HANDLE WITH CARE." In order to protect people and equipment, this display is attached to places where the Owner's Manual, Serviceman Manual and/or Service Manual should be referred to.

- **Perform work in accordance with the instructions herein stated.** Instructions for work are explained by paying attention to the aspect of accident prevention. Failing to perform work as per the instructions can cause accidents. In the case where only those who have technical expertise should perform the work to avoid hazardous situation, the instructions herein state that the site maintenance personnel should perform such work.
- **Be sure to turn off the power before working on the machine.** To prevent an electric shock, be sure to turn off the power before carrying out any work that requires direct contact with the interior of the product. If the work is to be performed in the power-on status, the Instruction Manual herein always states to that effect.
- **Be sure to ground the Earth Terminal** (This is not required in the case where a power cord with earth is used).
- **This product is equipped with the Earth Terminal.** When installing the product, connect the Earth Terminal to the "accurately grounded indoor earth terminal" by using an earth wire. Unless the product is grounded appropriately, the user can be subject to an electric shock. After performing repair, etc. for the control equipment, ensure that the Earth Wire is firmly connected to the control equipment.
- **Ensure that the Power Supply used is equipped with an Earth Leakage Breaker.** This product does not incorporate the Earth Leakage Breaker. Using a power supply which is not equipped with the Earth Leakage Breaker can cause a fire when earth leakage occurs.
- **Be sure to use fuses which meet the specified rating** (only for the machines which use fuses). Using fuses exceeding the specified rating can cause a fire and an electric shock (only for the machines which use fuses). Using fuses exceeding the specified rating can cause a fire and an electric shock.

- **Specification changes (removal of equipment, conversion and/or addition) not designated by SEGA are not allowed.** The parts of the product include warning labels for safety, covers for personal protection, etc. It is hazardous to operate the product by removing parts and/or modifying the circuits. Should doors, lids and protective parts be damaged or lost, refrain from operating the product, and contact where the product was purchased from or the office herein stated. SEGA shall not be held responsible for any accidents, compensation for damage to a third party, resulting from the specifications not designated by SEGA.
- **Ensure that the product meets the requirements of appropriate electrical specifications.** Before installing the product, check for electrical specifications. SEGA products have a nameplate on which electrical specifications are described. Ensure that the product is compatible with the power supply voltage and frequency requirements of the location. Using any electrical specifications different from the designated specifications can cause a fire and an electric shock.
- **Install and operate the product in places where appropriate lighting is available, allowing warning labels to be clearly read.** To ensure safety for the customers, labels and printed instructions describing potentially hazardous situations are applied to places where accidents can be caused. Ensure that where the product is operated has sufficient lighting allowing the warnings to be read. If any label is peeled off, apply it again immediately. Please place an order with where the product was purchased from or the office herein stated.
- **When handling the monitor, be very careful (applies only to products with monitors).** Some of the monitor parts are subject to high tension voltage. Even after turning off the power, some portions are still subject to high tension voltage sometimes. Monitor repair and replacement should be performed only by those technical personnel who have knowledge of electricity and technical expertise.
- **Be sure to adjust the monitor properly (applies only to products with monitors).** Do not operate the product leaving on-screen flickering or blurring as it is. Using the product with the monitor not properly adjusted may cause dizziness or a headache to an operator, a player, or the customers.
- **When transporting or reselling this product, be sure to attach this manual to the product.**
- *In the case where commercially available monitors and printers are used in this product, only the contents relating to this product are explained herein. Some commercially available equipment has functions and reactions not stated in this manual. Read this manual together with the specific instruction manual of such equipment.*
- *Descriptions herein contained may be subject to improvement changes without notice.*
- *The contents described herein are fully prepared with due care. However, should any question arise or errors be found, please contact SEGA.*

INSPECTIONS IMMEDIATELY AFTER TRANSPORTING THE PRODUCT TO THE LOCATION

Normally, at the time of shipment, SEGA products are in a status allowing for usage immediately after transporting to the location. Nevertheless, an irregular situation may occur during transportation. Before turning on the power, check the following points to ensure that the product has been transported in a satisfactory status.

- Are there any dented portions or defects (cuts, etc.) on the external surfaces of the cabinet?
- Are casters and adjusters damaged?
- Do the power supply voltage and frequency requirements meet with those of the location?
- Are all wiring connectors correctly and securely connected? Unless connected in the correct way, connector connections can not be made accurately. Do not insert connectors forcibly.
- Do power cables have cuts and dents?
- Are all accessories available?
- Can all doors and lids be opened with the accessory keys? Can doors and lids be firmly closed?

TABLE OF CONTENTS

| | | |
|-----------|--|-----------|
| | INTRODUCTION | vi |
| 1 | HANDLING PRECAUTIONS | 1 |
| 2 | PRECAUTIONS REGARDING INSTALLATION LOCATION | 4 |
| | 2-1 LIMITATIONS OF USAGE | 5 |
| | 2-2 OPERATION AREA | 6 |
| | 2-3 OPERATION AREA - MULTIPLE CABINETS | 7 |
| 3 | PRECAUTIONS REGARDING PRODUCT OPERATION | 9 |
| | 3-1 BEFORE OPERATION | 9 |
| | 3-2 DURING OPERATION (PAYING ATTENTION TO CUSTOMERS) | 12 |
| 4 | PARTS DESCRIPTION | 14 |
| 5 | ACCESSORIES | 15 |
| 6 | ASSEMBLY AND INSTALLATION | 17 |
| | 6-1 UNPACKING THE CABINETS | 20 |
| | 6-2 JOINING THE CABINETS | 22 |
| | 6-3 INSTALLING THE BILLBOARD | 25 |
| | 6-4 INSTALLING MULTIPLE CABINETS | 27 |
| | 6-5 LINKING THE CABINETS (COMMUNICATION) | 28 |
| | 6-6 APPLYING POWER | 29 |
| 7 | PRECAUTIONS WHEN MOVING | 32 |
| | 7-1 MOVING THE MACHINE | 33 |
| 8 | GAME DESCRIPTION | 35 |
| 9 | EXPLANATION OF TEST AND DATA DISPLAY | 46 |
| | 9-1 SWITCH UNIT | 47 |
| | 9-2 TEST MODE | 48 |
| 10 | VIDEO DISPLAY | 69 |
| | 10-1 GENERAL DESCRIPTION | 69 |
| | 10-2 CLEANING THE SCREEN | 70 |
| | 10-3 ADJUSTMENT METHOD | 71 |
| 11 | CONTROL UNITS | 75 |
| | 11-1 CONTROLLER - EXPLODED DIAGRAM | 77 |
| | 11-2 BRAKE AND ACCELERATOR UNIT | 78 |
| | 11-3 ADJUSTING/REPLACING THE VOLUME POT | 80 |
| | 11-4 GREASING | 81 |
| | 11-5 SHIFT LEVER | 82 |

| | | |
|-----------|--|------------|
| 12 | COIN HANDLING | 84 |
| | 12-1 CLEANING THE COIN SELECTOR | 84 |
| | 12-2 FAULT FINDING | 87 |
| | 12-3 ADJUSTING THE PRICE OF PLAY (EXCEL) | 88 |
| | 12-4 ADJUSTING THE PRICE COMMON (USA) | 89 |
| 13 | LAMPS AND LIGHTING | 90 |
| | 13-1 COIN DOOR LAMP | 90 |
| | 13-2 START/VIEW BUTTON PANEL | 91 |
| | 13-3 FOOTWELL LIGHTING | 93 |
| | 13-4 INNER PANEL LIGHTING | 95 |
| | 13-5 SEAT RING LIGHTING | 97 |
| | 13-6 BILLBOARD LIGHTING | 98 |
| | 13-7 UNDER SEAT LIGHTING | 100 |
| 14 | PERIODIC INSPECTION | 101 |
| | 14-1 GREASING | 103 |
| 15 | TROUBLESHOOTING & ERROR CODES | 104 |
| 16 | GAME BOARD | 109 |
| | 16-1 HOW TO REMOVE GAME BOARD | 110 |
| | 16-2 GAME BOARD CONNECTORS | 112 |
| 17 | DESIGN RELATED PARTS | 113 |
| 18 | PARTS LIST | 115 |
| 19 | WIRE COLOUR CODE TABLE | 139 |
| 20 | SCHEMATIC DIAGRAMS | 140 |

1 HANDLING PRECAUTIONS

When installing or inspecting the machine, be very careful of the following points and pay attention to ensure that the player can enjoy the game safely.

Non-compliance with the following points or inappropriate handling running counter to the cautionary matters herein stated can cause personal injury or damage to the machine.

WARNING

- Before performing work, be sure to turn the power off. Performing the work without turning the power off can cause an electric shock or short circuit. In the case that work should be performed in the status of power on, this manual always states to that effect.
- To avoid an electric shock or short circuit, do not plug in or unplug quickly.
- To avoid an electric shock, do not plug in or unplug with a wet hand.
- Do not expose power cords or earth wires on the surface, (floor, passage, etc.). If exposed, the power cords and earth wires are susceptible to damage. Damaged cords and wires can cause an electric shock or short circuit.
- To avoid causing a fire or an electric shock, do not put things on or damage the power cords.
- During/after installing the product, do not unnecessarily pull the power cord. If damaged, the power cord can cause a fire or an electric shock.
- In case the power cord is damaged, ask for a replacement through where the product was purchased from or the office herein stated. Using the cord as is damaged can cause fire, an electric shock or leakage.
- Be sure to perform grounding appropriately. Inappropriate grounding can cause an electric shock.
- Be sure to use fuses meeting the specified rating. Using fuses exceeding the specified rating can cause a fire or an electric shock.
- Be sure that connections such as IC BD are made properly. Insufficient insertion can cause an electric shock.
- Specification changes, removal of equipment, conversion and/or addition, not designated by SEGA are not permitted.
 - Failure to observe this may cause a fire or an electric shock. Non-compliance with this instruction can have a bad influence upon physical conditions of the players or the onlookers, or result in injury during play.
 - SEGA shall not be held responsible for damage, compensation for damage to a third party, caused by specification changes not designated by SEGA.
- Do not perform any work or change parts not listed in this manual. Doing so may lead to an accident.

If you need to perform any work not listed in this manual, request work from the office indicated in this manual or the point of purchase, or inquires for details.
- Be sure to perform periodic maintenance inspections herein stated.

2 PRECAUTIONS REGARDING INSTALLATION LOCATION

WARNING

This product is an indoor game machine. Do not install it outside. Even indoors, avoid installing in places mentioned below so as not to cause a fire, electric shock, injury and/or malfunction:

- Places subject to rain, water leakage, or places subject to high humidity in the proximity of an indoor swimming pool and/or shower, etc.
- Places subject to direct sunlight, or places subject to high temperatures in the proximity of heating units, etc.
- Places filled with inflammable gas or vicinity of highly inflammable/volatile chemicals or hazardous matter.
- Dusty places/areas.
- Sloped surfaces.
- Places subject to any type of violent impact.
- Vicinity of anti-disaster facilities such as fire exits and fire extinguishers.
- The operating (ambient) temperature range is not from 5°C to 30°C.
- Places near water or spray from water such as a jet wash or swimming pool.

2-1 LIMITATIONS OF USAGE

WARNING

- Be sure to check the Electrical Specifications. Ensure that this product is compatible with the location's power supply, voltage, and frequency requirements. A plate describing Electrical Specifications is attached to the product. Non-compliance with the Electrical Specifications can cause a fire and electric shock.
- This product requires a breaker and earth mechanism as part of the location facilities. Using the product without these can cause a fire and electric shock.
- Ensure that the indoor wiring for the power supply is rated at 15 A or higher (AC single phase 100 V ~ 120 V area), and 7 A or higher (AC 220 V ~ 240 V area). Non-compliance with the Electrical Specifications can cause a fire and electric shock.
- Be sure that the ring main has a rating of 32A (AC220V ~ 240V area).
- Be sure to use an independent power supply equipped with an earth leakage breaker. Using a power supply without an earth leakage breaker can cause an outbreak of fire if a power surge occurs.
- Putting many loads on one electrical outlet can cause generation of heat and a fire resulting from overload.
- When using an extension cord, ensure that the cord is rated at 15 A or higher (AC 100 V ~ 120 V area) and 7 A or higher (AC 220 V ~ 240 V area). Using a cord rated lower than the specified rating can cause a fire and electric shock.

2-2 OPERATION AREA

 **WARNING**

- For the operation of a single machine, secure a minimum area of 2.1m (82.6in) (W) x 2.3m (90.5in) (D). If the machine rolls during play it could lead to serious injury. You must secure an area equal to or greater than the space specified in this document.
- Be sure to provide sufficient space specified in this manual. Do not allow objects to block the ventilation ports. Doing so can cause generation of heat and fire.
- SEGA shall not be held responsible for damage or compensation for damage to a third party, resulting from the failure to observe this instruction.
- If the machine does not fit through the entryway to the installation location, do not disassemble it without first consulting the instructions. If the machine still does not fit through the entryway after following the procedures in this manual, contact your retailer or the office listed in this manual.

 **IMPORTANT**

To install this product, the entrance must be at least 1.07 m in width and 1.5 m in height.

Secure an area of no less than 2.1m (82.6in) x 2.3m (90.5in) for operation, taking into consideration the safety of the players and spectators of this game.

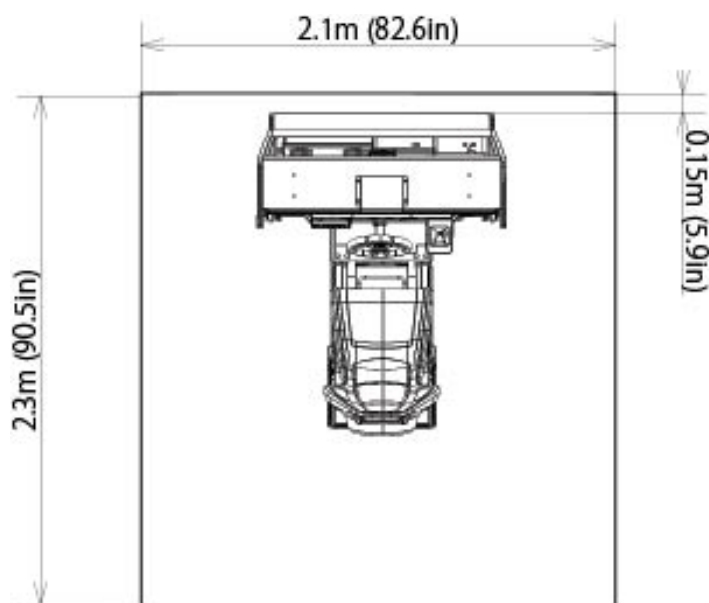

2-2 fig. 01

2-3 OPERATION AREA - MULTIPLE CABINETS

STOP IMPORTANT

Secure an area of no less than 3.3m (129in) x 2.3m (90.5in) for operation of the TWIN cabinet, taking into consideration the safety of the players and spectators of this game.

To install this product, the entrance must be at least 1.05 m in width and 1.5m in height.

When installing multiple cabinets, make sure the rules are followed below.

1. Keep a distance of no greater than 5mm (3/16in) between each Monitor Cabinet.
2. Keep a distance of a minimum of 0.5m either side of the end cabinets.
3. Keep a minimum distance of 0.15m at the rear of the cabinet for ventilation.

Two cabinet formation. (Twin)

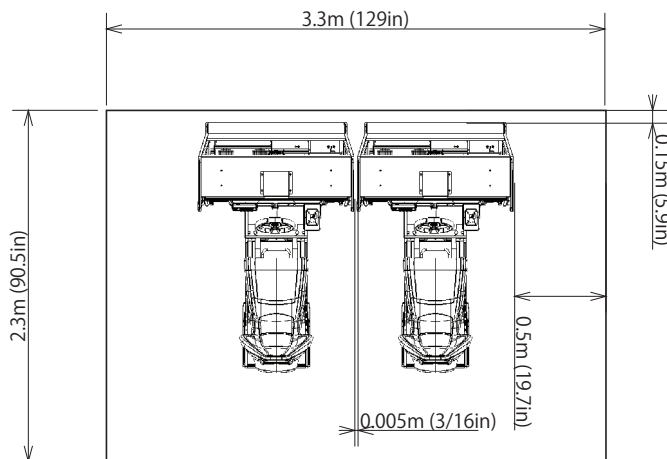

2-2 fig. 02

Four cabinet formation.

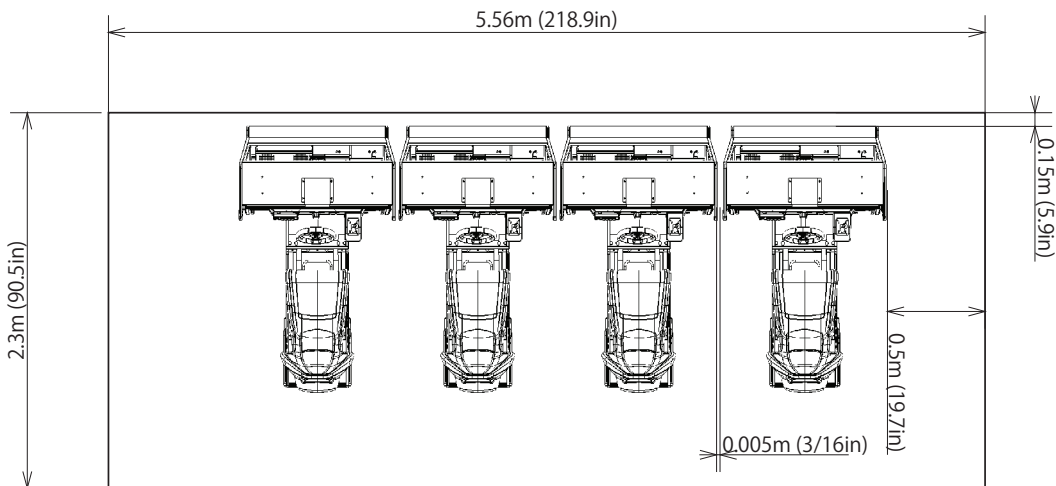

2-2 fig. 03

Eight cabinet formation.

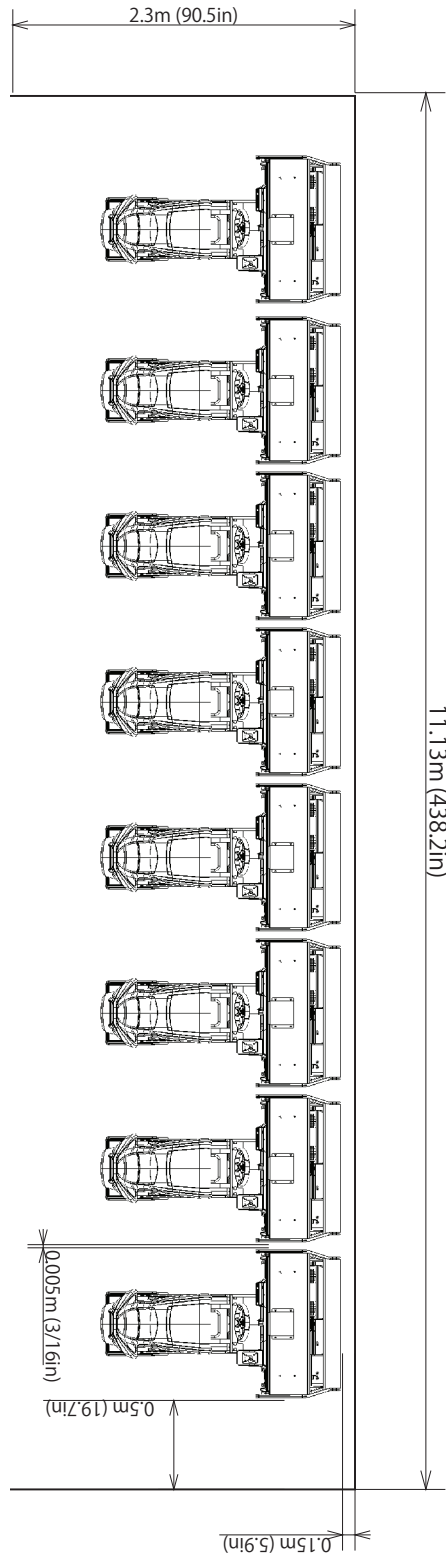

2-2 fig. 04

3 PRECAUTIONS REGARDING PRODUCT OPERATION

To avoid injury and trouble, be sure to pay attention to the behavior of visitors and players.

3-1 BEFORE OPERATION

WARNING

In order to avoid accidents, check the following before starting the operation:

- To ensure maximum safety for the players and customers, ensure that where the product is operated has sufficient lighting to allow any warnings to be read. Operation under insufficient lighting can cause bodily contact with each other, hitting accidents, and/or trouble between customers.
- Be sure to perform appropriate adjustment of the monitor. For operation of this machine, do not leave monitor flickering or deviation as is. Failure to observe this can have a bad influence upon the players' or customers' physical conditions.
- It is suggested to ensure a space allowing the players who feel sick while playing the game to take a rest.
- Check if all of the adjusters are in contact with the surface. If they are not, the Cabinet can move and cause potential accidents.

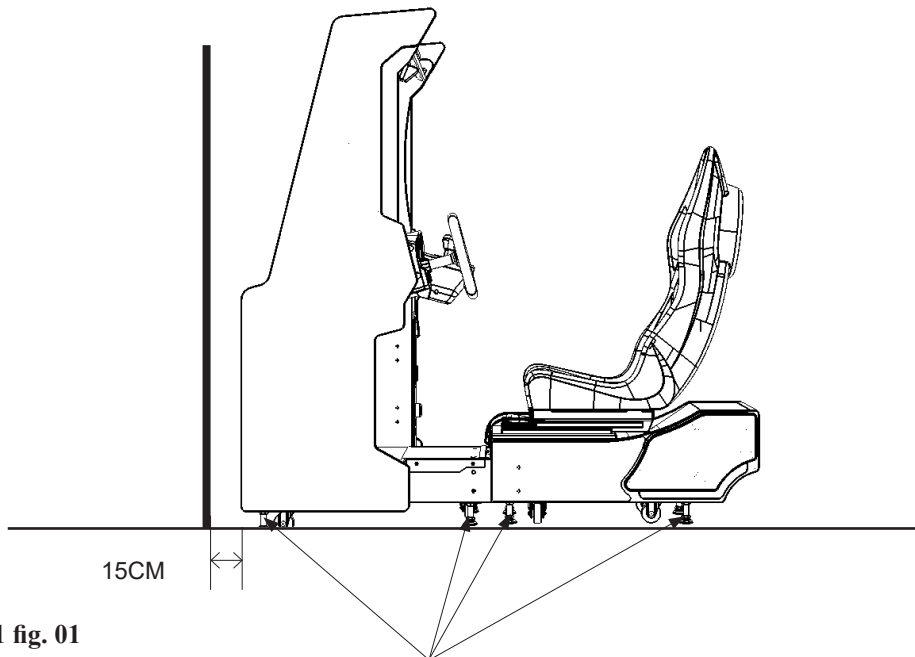

03-1 fig. 01

Ensure that all of the 8 adjusters are in contact with the floor.
Provide a gap at the back of the cabinet of no less than 15cm.

⚠ WARNING

- Do not put any heavy item(s) on this product. Placing any heavy item on the product can cause falling accidents or parts damage.
- Do not climb on the product. Climbing on the product can cause falling accidents. To check the top portion of the product, use a step ladder.
- When using a stepladder or stool while working, do not hold onto the billboard by any electrical components. Holding the billboard in these areas may cause damage, electronic component failure or personal safety issues.
- To avoid electric shock, check to see if door & cover parts are damaged or omitted.
- To avoid electric shock, short circuit and/or parts damage, do not put the following items on or in the periphery of the product:
 - Flower vases, flowerpots, cups, water tanks, cosmetics, and receptacles/containers/vessels containing chemicals or water

⚠ CAUTION

- To avoid injury, be sure to provide sufficient space by considering the crowd situation at the installation location. Insufficient installation space can cause customers to bump into each other and could cause injury.
- Every day when cleaning the Controller (Steering Wheel), inspect the hoop and buttons, making sure that there are no scratches or cracks in the surface, and that the fastening screws are not loose. If the game is played with scratches, cracks, or loose screws, it can cause injuries to the player or to people nearby.

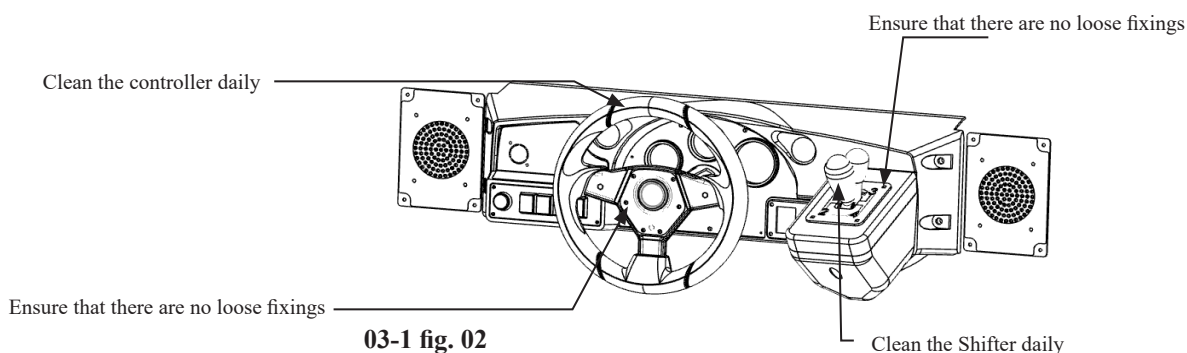

- When you clean the cabinet each day, always make sure that there is nothing placed on the seats and that they are not damp or wet.

STOP IMPORTANT

To ensure customers enjoy playing the game, clean the Control Unit regularly. If there is any dirt buildup, the hoop may become slippery or tacky, resulting in an unpleasant experience for the player.

DURING OPERATION (PATRON CONDUCT)

To avoid injury and unacceptable behavior, be sure to constantly give careful attention to the behavior and manner of the spectators and players alike.

WARNING

To avoid injury and accidents, those who fall under the following categories are not allowed to play the game:

- Those who need assistance such as the use of an apparatus when walking.
- Those who have high blood pressure or a heart problem.
- Those who have experienced muscle convulsion or loss of consciousness when playing video game, etc.
- Those who have neck and/or spinal cord problems.
- Intoxicated persons.
- Pregnant women or those who are in the likelihood of pregnancy.
- Persons susceptible to motion sickness.
- Persons whose actions run counter to the product's warning displays.

A player who has never been adversely affected by light stimulus might experience dizziness or headache depending on his physical condition when playing the game.

Instruct those who feel sick during play to have a medical examination.

To avoid injury resulting from falling down and electric shock due to spilled drinks, instruct the player not to place heavy items or drinks on the product.

To avoid electric shock and short circuit, do not allow patrons to put hands, fingers or extraneous matter in the openings of the product or small openings in or around the doors.

To avoid injury resulting from falling down, immediately stop patrons leaning against or climbing on the product, etc.

To avoid electric shock and short circuit, do not allow patrons to unplug the power plug without a justifiable reason.

Players should be warned not to place children on their lap while playing the game. Doing so may cause the child or part of the child to become trapped within the working of the machine. i.e. Controller, Seat, Pedals.

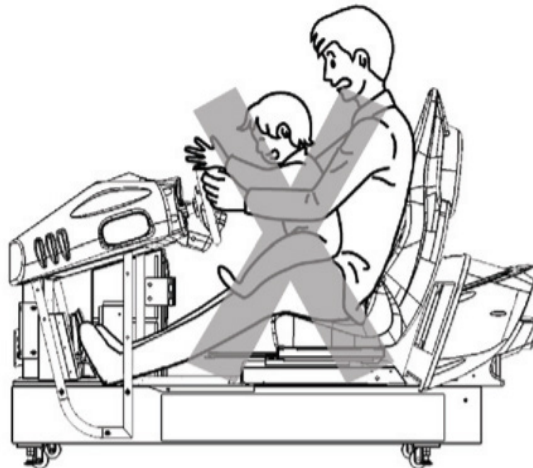

Never have more than 1 player playing the game at any one time. Having two or more people playing this game at the same time may result in injuries.

03-1 fig. 03

3-2 DURING OPERATION (PAYING ATTENTION TO CUSTOMERS)

To avoid injury and trouble, be sure to pay attention to the behavior of visitors and players.

WARNING

- For safety reasons, do not allow any of the following people to play the game:
 - Those who require supporting devices (or the like) to walk.
 - Those who have high blood pressure or a heart problem.
 - Those who have experienced muscle convulsion or loss of consciousness when playing video games, etc.
 - Those who have neck or spinal cord problems.
 - Intoxicated persons.
 - Pregnant women.
 - Persons susceptible to motion sickness.
 - Persons who disregard the product's warning displays.
- Even players who have never been adversely affected by light stimulus might experience dizziness or headache depending on their physical condition when playing the game. Small children are especially likely to experience these symptoms. Caution guardians of small children to keep watch on them during play.
- Instruct those who feel sick during play to have a medical examination.
- To avoid injury from falls and electric shocks due to spilled drinks, instruct the player not to place heavy items or drinks on the product.
- To avoid electric shocks and short circuits, do not allow customers to put hands and fingers or extraneous matter in the openings of the product or small openings in or around the doors.
- To avoid falls and resulting injury, stop the customer from leaning against or climbing on the product, etc.
- To avoid electric shock and short circuit, do not allow customers to unplug the power plug without a justifiable reason.

CAUTION

- Immediately stop such violent acts such as hitting and kicking the product. Such violent acts can cause parts damage or falling down, resulting in injury due to fragments.
- Two or more players must never be allowed to play using a single Control Unit. Playing in such a way could lead to physical injuries.
- Players should be warned not to place personal effects or other objects on the base of the machine. If the safety sensor fails to detect these items, the motion of the machine may cause them to fly out and strike other patrons.
- Players should be instructed to adjust the seat by moving it forward or backward to fit their body size before playing the game. Playing the game in an unnatural position can lead to unforeseen accidents.
- Persons other than the player should not be allowed to touch the controls during play. They may brush against or collide with the controls or the player, possibly resulting in accidents.
- Player should be informed/instructed to consider their environment before adjusting the seat.

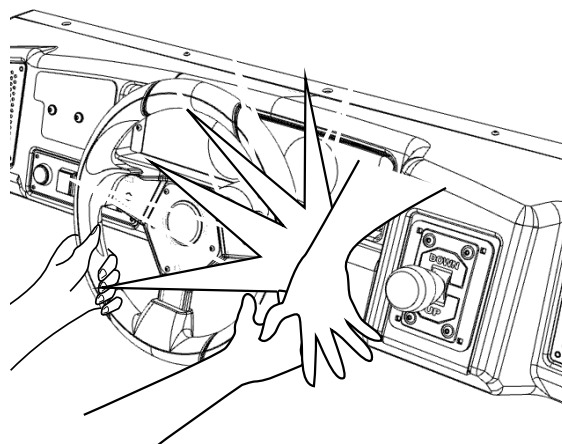

03-2 fig. 01

4 PARTS DESCRIPTION

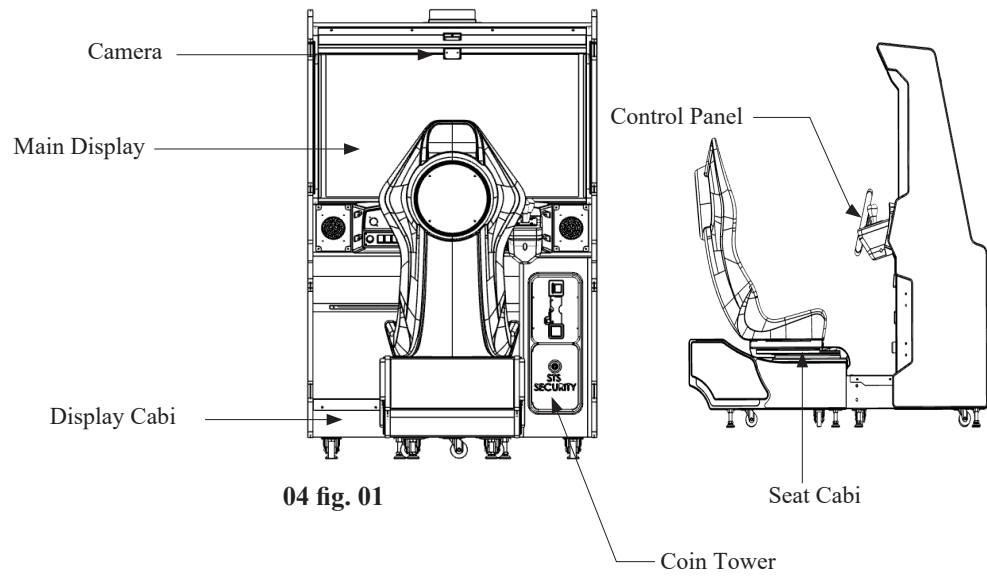

04 fig. 01

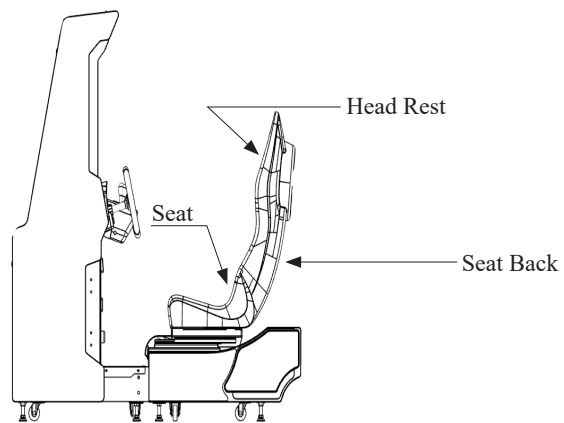

04 fig. 02

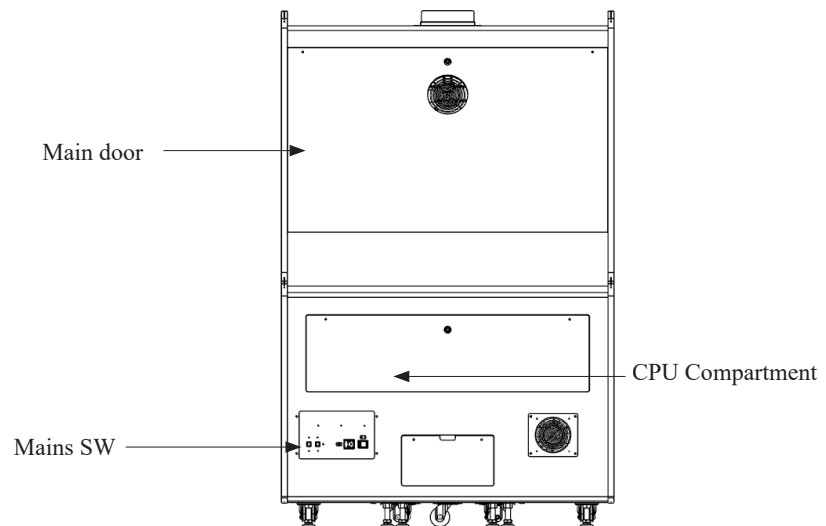

04 fig. 03

5 ACCESSORIES

Confirm that the accessories listed on this page are present when setting up the product.
Accessories marked “Spare” in the note column are consumable items but included as spares.

OWNER’S and SERVICE MANUAL

420-0028-05UK (1)

This manual

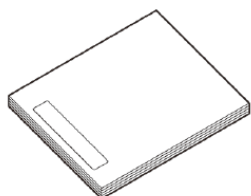

05 fig. 01

POWER CABLE

LM1227 (1) <UK>

LM1246 (1) <European>

LM1550 (1) <America>

For installation, see chapter 6

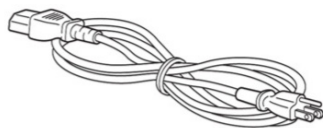

05 fig. 02

KEY

(2)

For the cashbox door
(Attached to the Steering Wheel
at time of shipment)

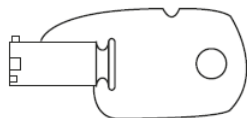

05 fig. 03

MASTER KEY

220-5575UK (4)

For opening/closing the doors
(Packaged with this manual, in the box supplied with
the product)

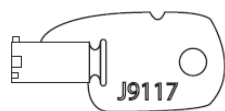

05 fig. 04

STICKER SHEET C EPILEPSY MULTI

440-CS0186UKUK (1)

Multilingual caution label - epilepsy seizure
(English version fitted as standard)

*Please see “Introduction” section of this manual for
label positioning.*



05 fig. 05

Network (Lan) Cable

(2m)

For linking a twinned cabinet for
network play.



05 fig. 06

The parts listed in Table 5b are needed to finalise the installation. These are traditionally parts that are applied by the customer at location. Please take a moment to check the contents. If for some reason some the parts are not present, call your local office along with the machine serial number to arrange for the relevant parts to be sent to you (PLEASE NOTE THAT SOME ITEMS ARE ALREADY FITTED TO LOCATION TO AID INSTALL)

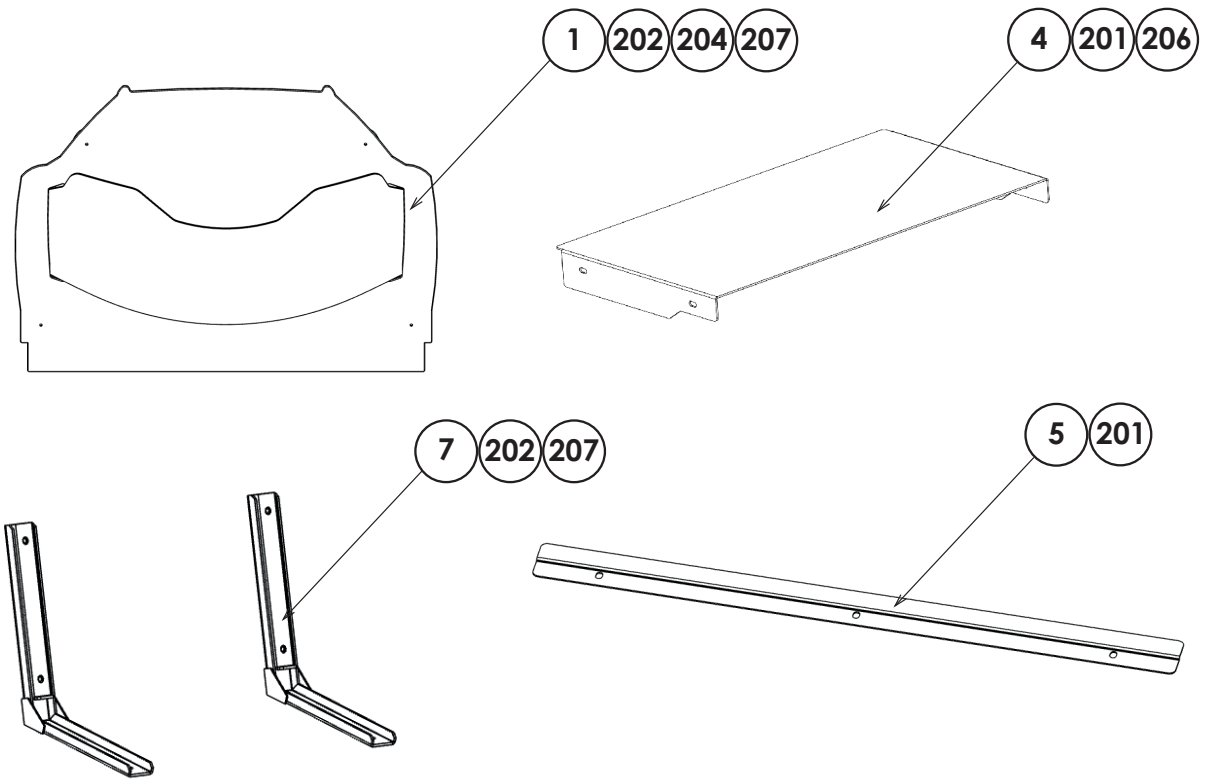

| ITEM NO | PART NO | DESCRIPTION | REFERENCE | QTY |
|---------|------------|----------------------|----------------|-----|
| **1 | DA-7800UK | ASSY BILLBOARD | | 1 |
| **4 | DA-7053UK | FOOTWELL LID | FITTED IN SITU | 1 |
| **5 | DA-7054UK | SASH FOOTWELL LID | FITTED IN SITU | 1 |
| **7 | DA-7011UK | MOUNT BILLBOARD CABI | | 2 |
| **201 | 029-B00425 | M4X25 SKT BH PAS | | 7 |
| **202 | 029-B00625 | M6X25 SKT BH PAS | | 11 |
| **204 | 060-S00600 | M6 WSHR SPR PAS | | 3 |
| **206 | 068-441616 | M4 WSHR 16OD FLT PAS | | 7 |
| **207 | 068-652016 | M6 WSHR 20OD FLT PAS | | 11 |

6 ASSEMBLY AND INSTALLATION

WARNING

- Perform assembly work by following the procedure herein stated. Failure to comply with the instructions can cause electric shock.
- Perform assembling as per this manual. Since this is a complex machine, incorrect assembling can cause an electric shock, machine damage and/or improper functioning as per specified performance.
- When assembling, more than one person is required. Depending on the assembly work, there are some cases in which working by one person alone can cause personal injury or parts damage.
- Ensure that connectors are properly connected. Improper connections can cause electric shock.
- Be careful not to damage any wires. Damaged wires may cause electric shock or short circuit or present a risk of fire.
- This work should be carried out by site maintenance personnel or other qualified professionals. Work performed by non-technical personnel can cause a severe accident such as electric shock. Failing to comply with this instruction can cause a severe accident such as electric shock to the player during operation. If no one with proper technological expertise is available, request service from the office indicated in this document or the point of purchase so as to ensure safety.
- Provide sufficient space so that assembling can be performed. Performing work in places with narrow space or low ceiling may cause an accident and assembly work to be difficult.
- To perform work safely and avoid serious accident such as the cabinet falling down, do not perform work in places where step-like grade differences, a ditch, or slope exist.
- Do not leave power cords or ground wires exposed in areas of heavy foot traffic. Doing so may cause them to become damaged, possibly resulting in electric shock and/or short circuits. When laying wiring across the floor, always use safety covers to protect the wires (wiring diameter: power cable - approx. \varnothing 8).
- Have a flashlight or another supplementary lighting unit available while working. With indoor lighting alone, the cabinet interior may be too dark. Working without proper lighting can lead to accidents. It also hinders proper work performance.
- The cabinet has ventilation ports. Be sure not to block them. If they are blocked, heat can build up, leading to fire. This can also accelerate wearing of parts and malfunctions.
- Secure ample ventilation space around the cabinet. If heat builds up, there could be accidents associated with heat or smoke generation.
- This product does not use any connectors other than those connected to and used by the game board when it leaves the factory. Do not needlessly connect wires to unused connectors. This could lead to overheating, generation of smoke and burn related injuries.

 **CAUTION**

- Handle molded parts with care. Excessive weight or pressure may cause them to break and the broken pieces may cause injury.
- To perform the operation safely and accurately, use a safe, steady footstool or stepladder. Working without this may lead to a fall and possible injury.
- Attempting to forcefully connect the incorrect connector or connecting a connector at the wrong angle or facing may damage the connector and could lead to overheating and burn related injuries.
- When attaching or removing doors or lids, be careful that your hand or finger does not get caught in anything.

 **IMPORTANT**

- Be very careful when handling LCD screen. The screen can be damaged easily and cannot be repaired once damaged. Such damage can only be repaired by completely replacing the screen.
- Be careful not to damage parts surfaces. In some cases, if such surfaces are damaged, the part must be replaced; it cannot be reinforced or repaired.

The assembly of this product is performed in the following 6 steps:

- 6.1 UNPACKING THE CABINET
- 6.2 JOINING THE CABINETS
- 6.3 INSTALLING THE BILLBOARD
- 6.4 INSTALLING MULTIPLE CABINETS (COMMUNICATION)
- 6.5 LINKING THE CABINETS (COMMUNICATION)
- 6.6 APPLYING POWER

Tools Required for Assembly Operation



- Philips screwdriver (for M4, M6 screws)

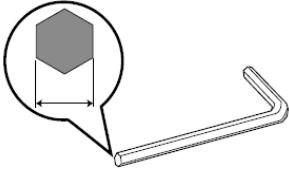

- Hex Drive for (M4, M6 & M8 screws)

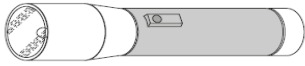

- A torch or any additional lighting

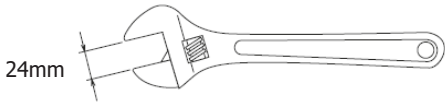

- A wrench or 24mm Spanner.



- Machine Keys (Supplied)

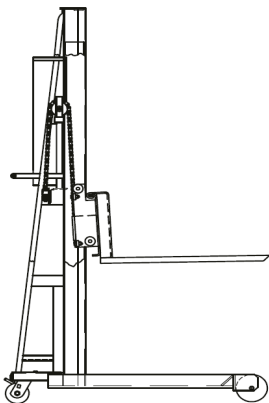

- Lifting equipment capable of lifting a weight of 250kg

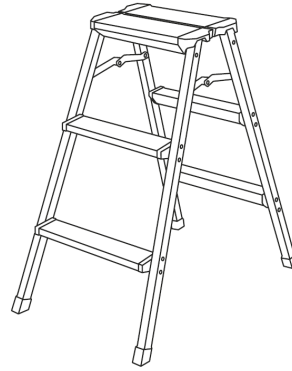

Locking Step Ladders -

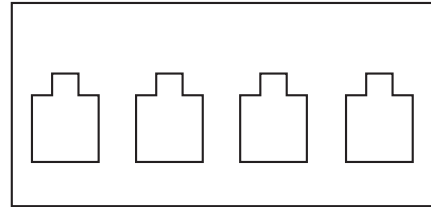

100Mb Network Switch
(Required for linking 3 or more cabs.
Sold separately).

6-1 UNPACKING THE CABINETS

STOP IMPORTANT

- Be very careful when removing the Monitor and Seat cabinets from the pallet. Use only hydraulic lifting equipment such as a fork lift. Some parts weigh in excess of 200Kgs. DO NOT attempt to remove the machine from the pallet by hand. Doing so may result in serious personal injury and/or damage to the cabinet and its components.
- There are 2 "LIFTING POINTS" highlighted on the lower front and rear parts of the machine by a  symbol. Always use these points when lifting.

Display Cabinet

This product is delivered as 3 individual components. 2 x Pallets for the two ASSY DISPLAY CABINETS and a single pallet for both ASSY SEATS. Take care when removing the machine from it's pallet. Only use appropriate lifting equipment such as a Fork Truck or similar lifting equipment. DO NOT attempt to remove by hand. Removing this product from its pallet by hand can cause severe injury and/or damage to the product and surrounding area.

The plastic outer covering is specially designed to fix the cabinet to the pallet. Once the plastic covering is removed, the machine will no longer be held securely to the pallet.

Remove the cabinet from it's pallet by approaching it from the rear. Using lifting equipment, carefully lift the machine up enough so that the pallet can be dragged from beneath it.

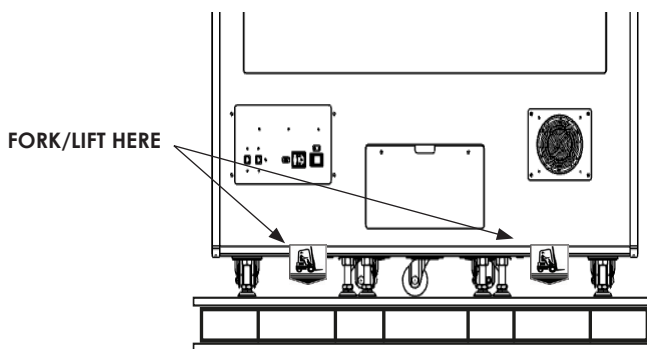

6-1 fig. 01

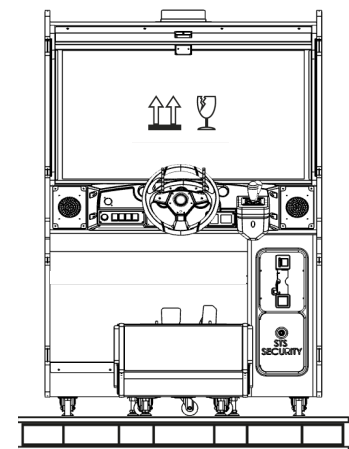

6-1 fig. 02

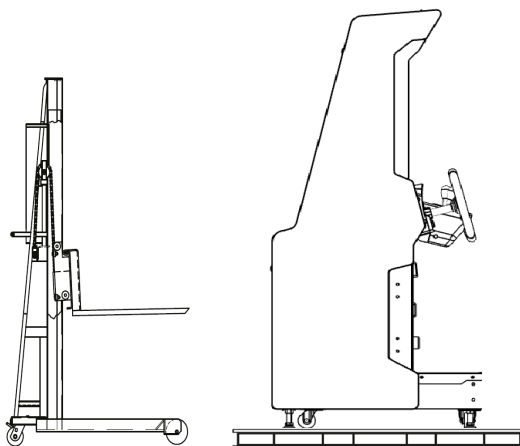

6-1 fig. 03

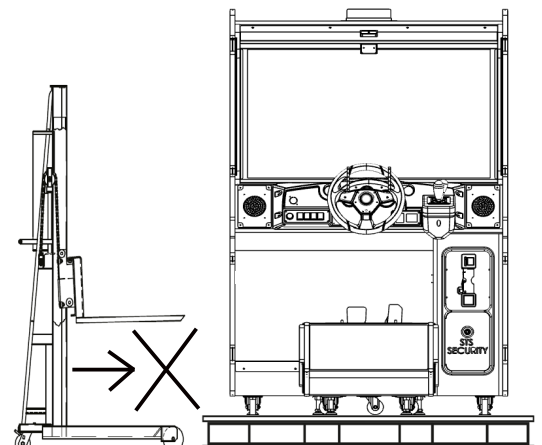

6-1 fig. 04

Seat Cabinet

The ASSY SEAT CABI are packed as pairs along with the INSTALLATION KIT. Like the DISPLAY CABI, the ASSY SEAT CABI's are attached to the pallet by means of a strong clear bag which is shrunk down to fit the contents within. Using a blade or scissors, carefully cut away the bag, from around the top edge of the pallet, taking care not to damage its contents.

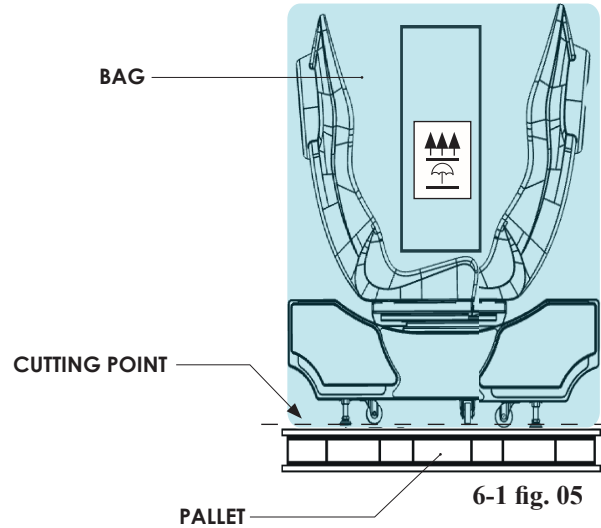

Using (2) people, carefully lift and remove the INSTALLATION KIT which rests across the top of the SEATS. DO NOT attempt to remove the INSTALLATION KIT single-handedly. Removing the Installation Kit single-handedly may result in either damage to components and/or personal injury.

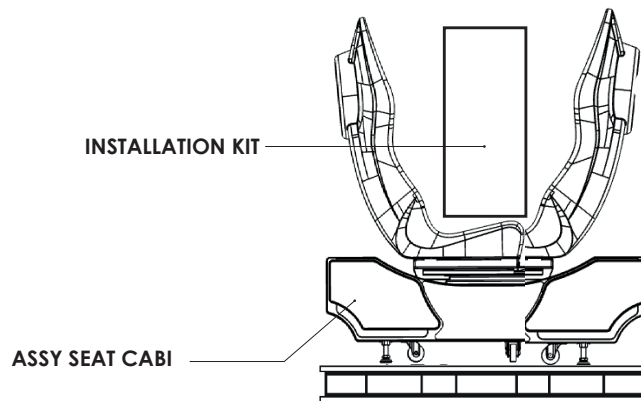

Remove the ASSY SEATS from the pallet using adequate lifting equipment. Failing to use such equipment may result in damage to components or personal injury.

⚠ HEAVY!

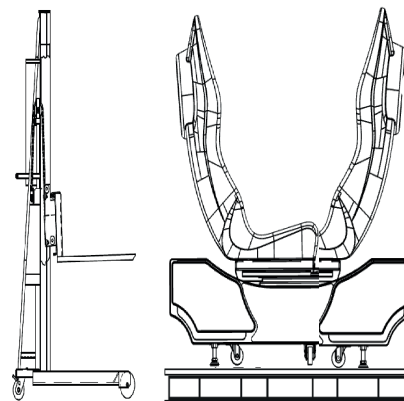

6-2 JOINING THE CABINETS

It is important that a suitable location is secured to enable installation to be carried out safely.
Please refer the beginning of this manual for Operational Area.

- 1 Making sure that the castors come into contact with the floor, carefully place and align both front and rear cabinets into position. Follow the guidelines in the OPERATIONAL AREA in the beginning of this manual.

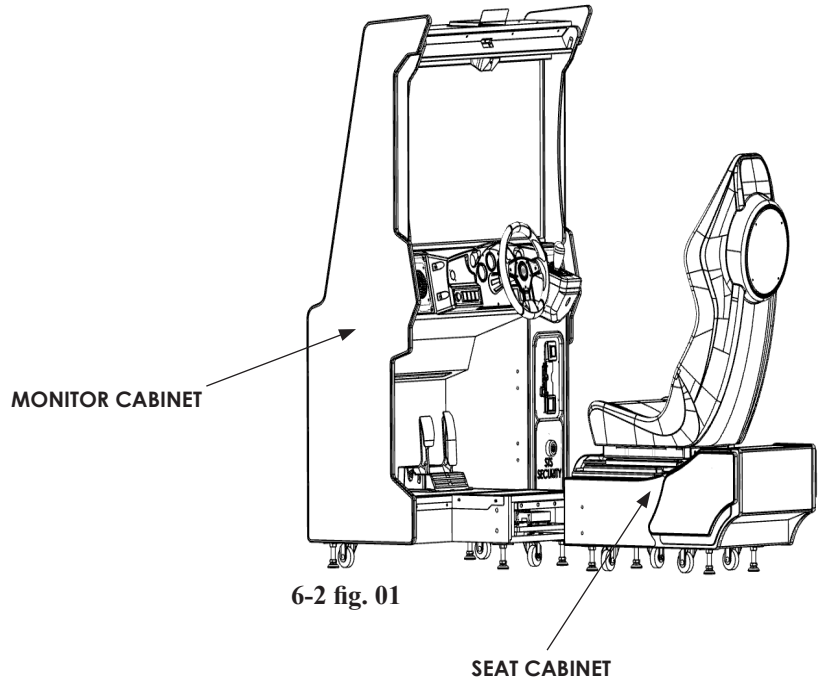

- 2 Connect the harnesses between the ASSY SEAT CABI and the ASSY MONITOR CABI.

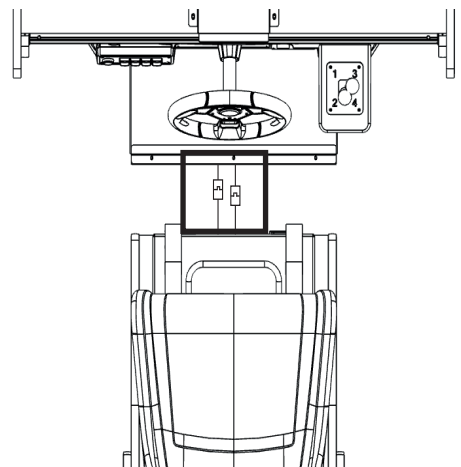

- 3** Carefully push the ASSY SEAT CABI up towards the ASSY MONITOR CABI, taking care not to trap any harnesses.

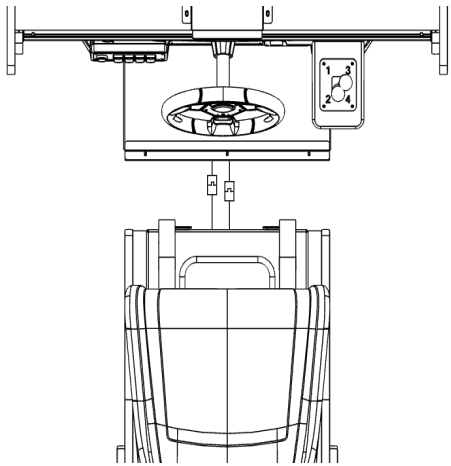

6-3 fig. 03

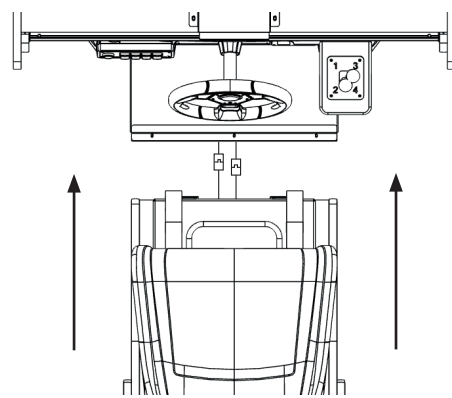

6-3 fig. 04

- 4** Once the SEAT CAB and MONITOR CAB are together, secure them using (4) M8 fixings in the positions illustrated below.

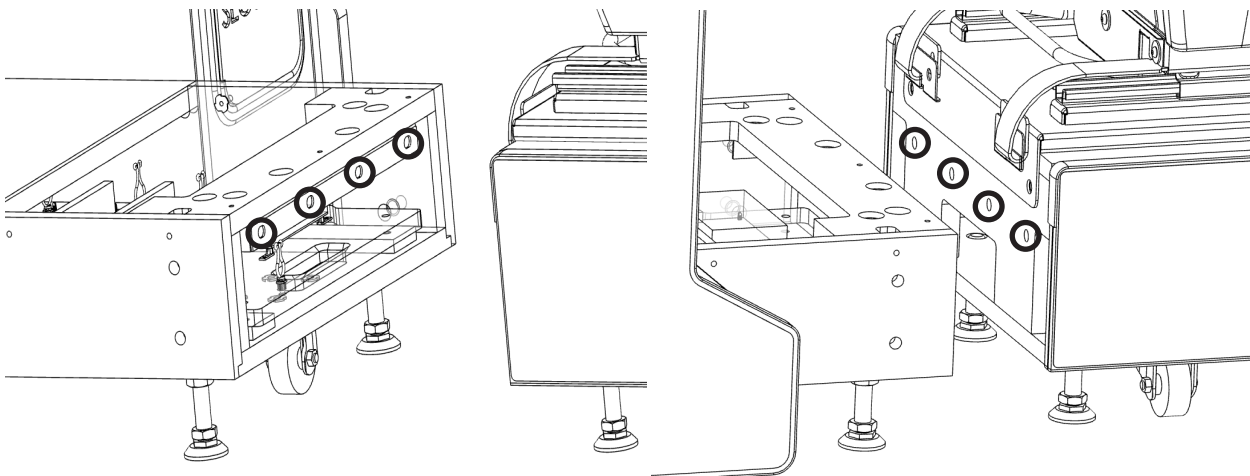

6-3 fig. 05

- 5 Secure the BRACKET JOINT INNER on the inside of the cabinets on both sides with (4) M4X25 fixings.

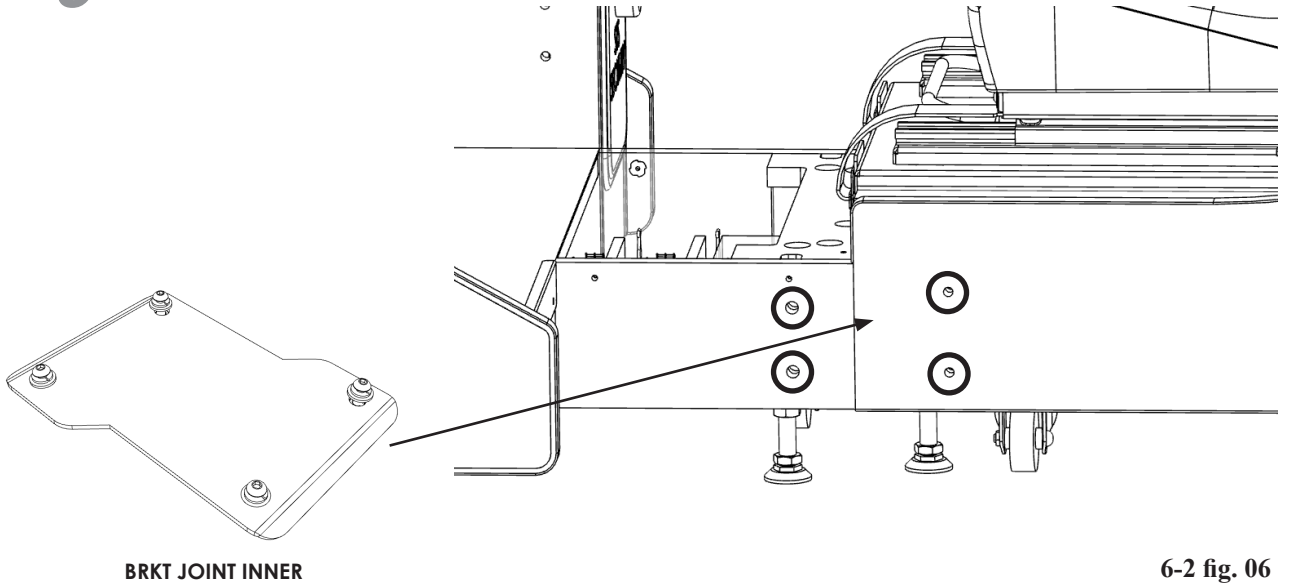

- 6 Secure the FOOTWELL LID from the Installation Kit with (4) M4X25 fixings.

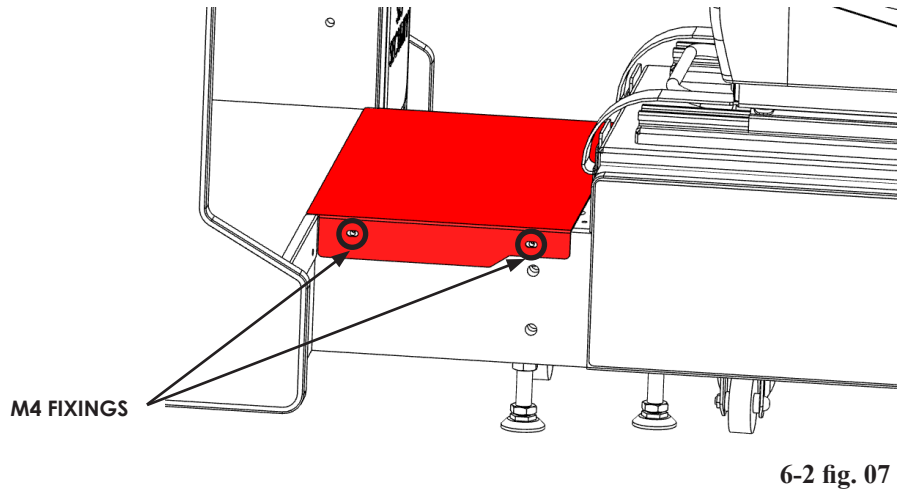

- 7 Secure the FOOTWELL LID SASH from the Installation Kit with (3) M4X25 fixings.

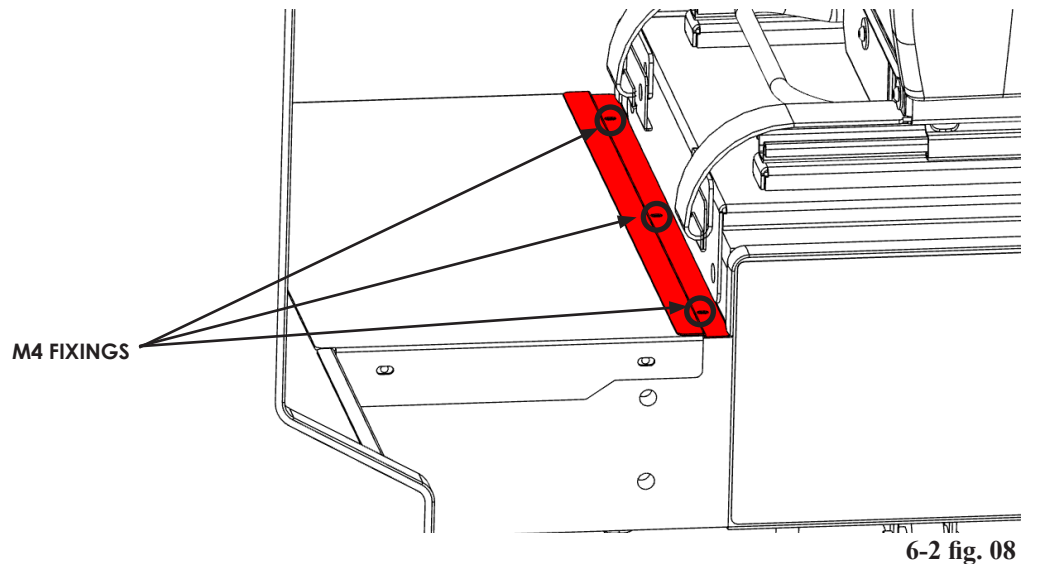

6-3 INSTALLING THE BILLBOARD

- 1 Attach the BILLBOARD MOUNT BRKTS using (2) M6X25 fixings on each bracket.

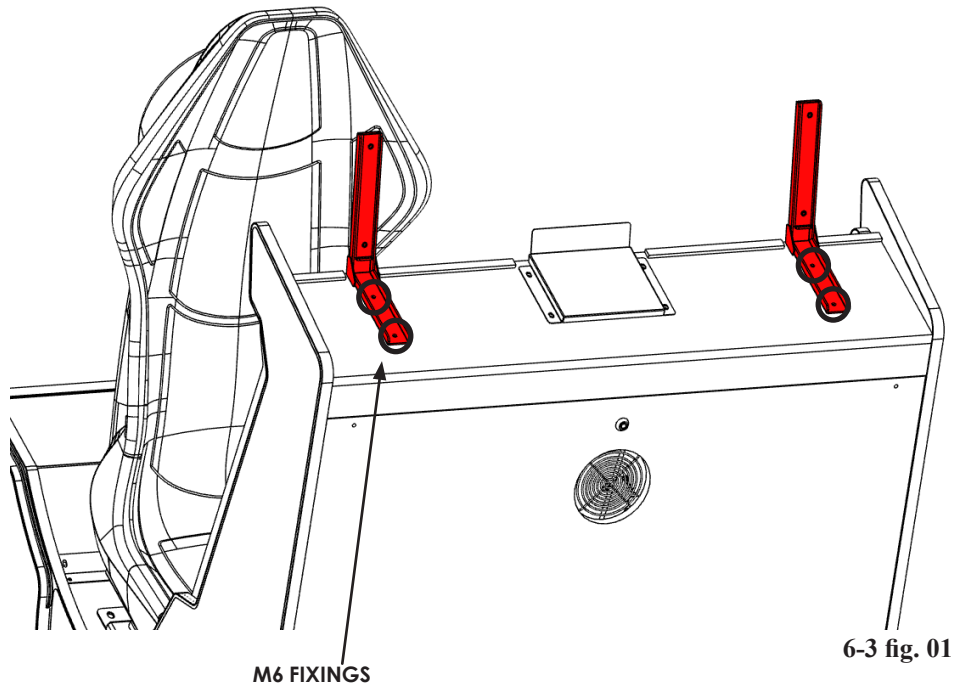

- 2 Mount the ASSY BILLBOARD by inserting the BRKT BILLBOARD over the BILLBOARD MOUNT BRKT.

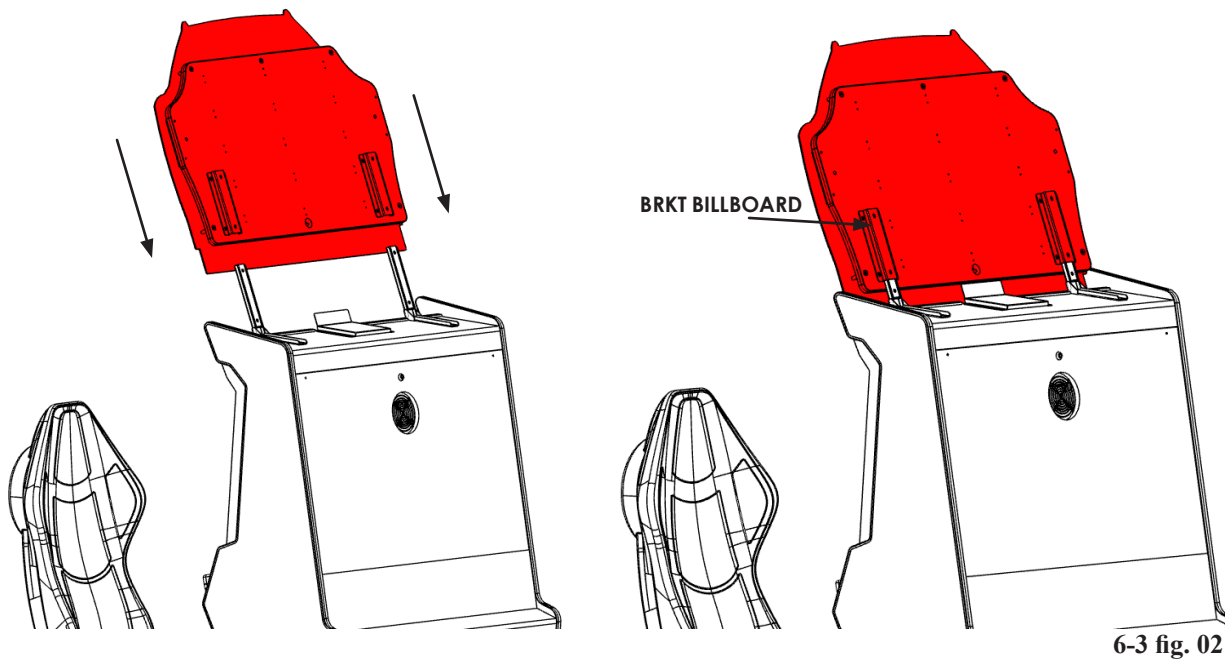

- 3 Secure the BILLBOARD in place using (2) M6X25 fixings on each bracket.

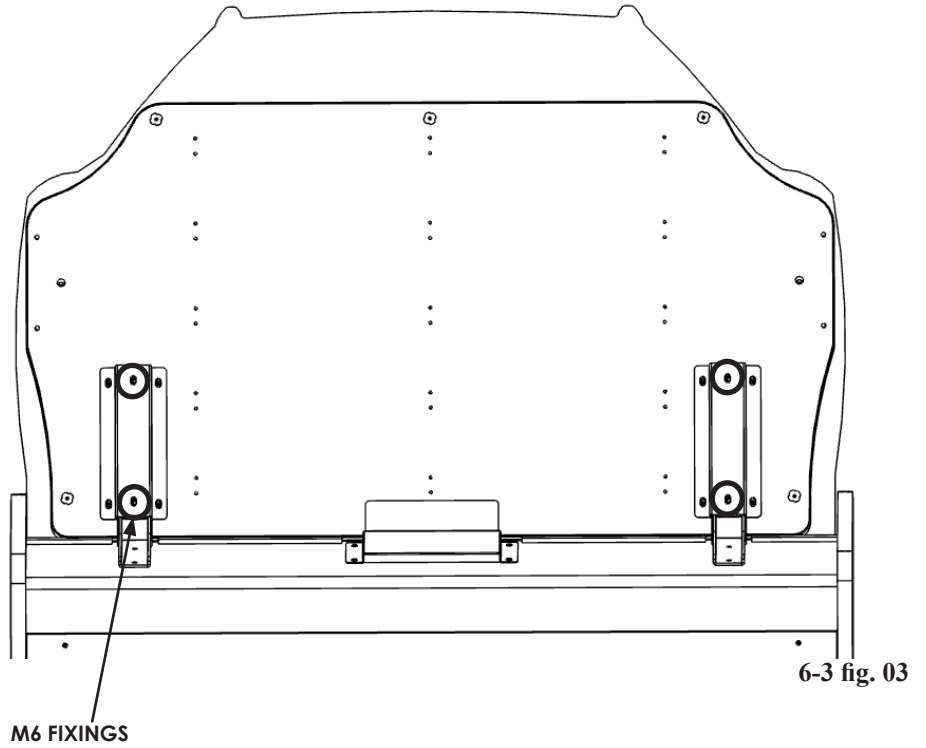

- 4 Secure the BILLBOARD BUMPER in place by inserting either the left or right side, then gently bending the bumper into position on the opposite side. Secure with (2) M4x50 fixings (1 on each side).

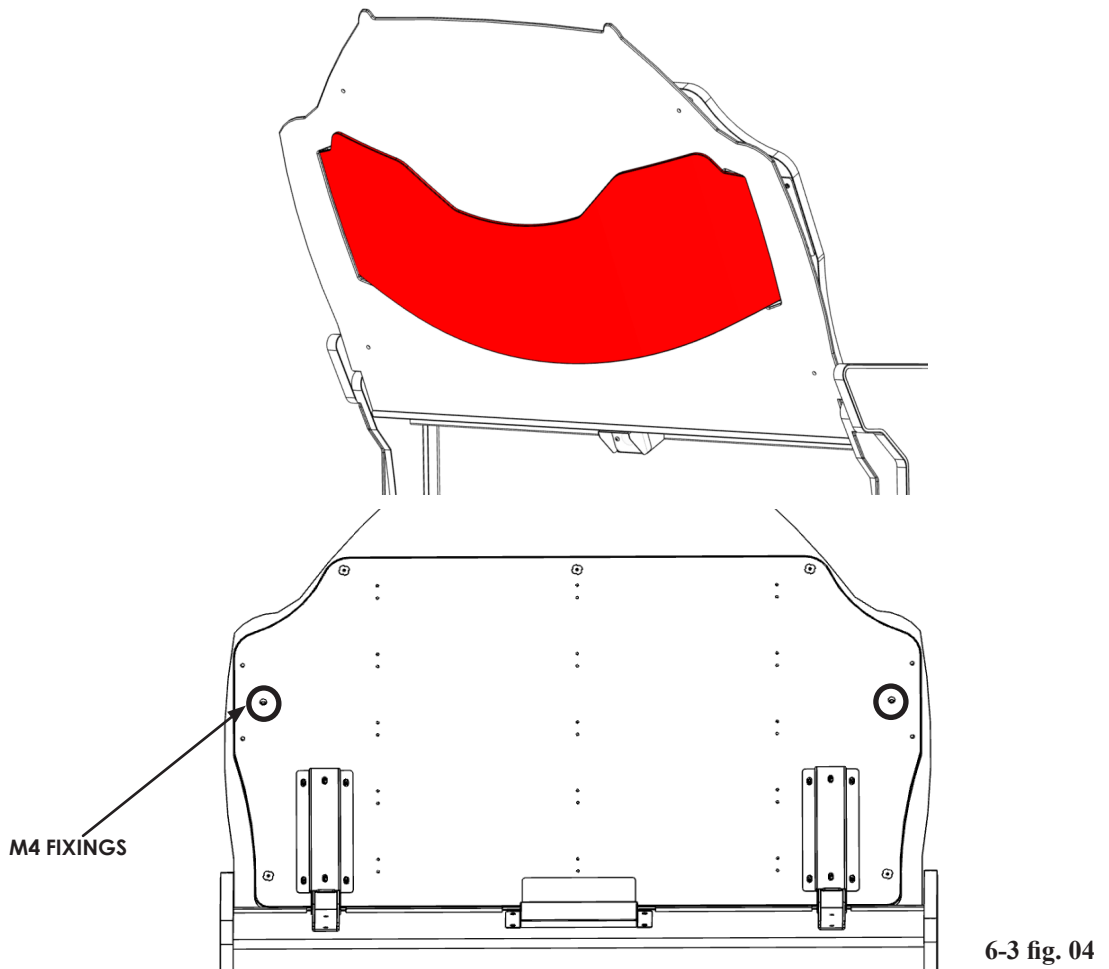

6-4 INSTALLING MULTIPLE CABINETS

It is important that a suitable location is secured to enable installation to be carried out safely.

Please refer the beginning of this manual for Operational Area.

For this exercise we will show the procedures for installing (2) cabinets. This will reflect the procedures for installing 4, 6 or 8 cabinets.

- 1 Carefully place (2) car units into position. Follow the guidelines in the OPERATIONAL AREA in the beginning of this manual.

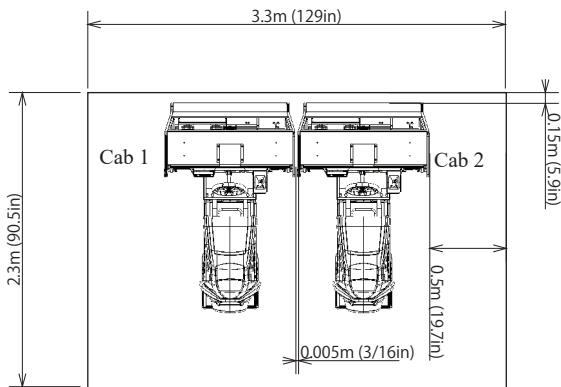

6-4 fig. 01

STOP IMPORTANT

Each cabinet has its own dedicated mains power input. Only use the power leads supplied with this machine. When connecting 4 or more cabinets together, please refrain from using Multi-socket extension cables. **DO NOT** place more than 2 units in a single Multi-socket extension cable (not supplied). Connecting more than 2 units in a single power extension cable may overload the circuit and cause possible electrical damage or even fire.

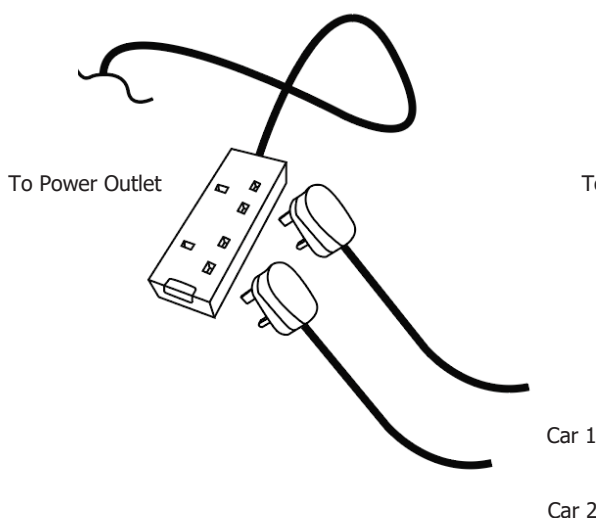

6-4 fig. 02

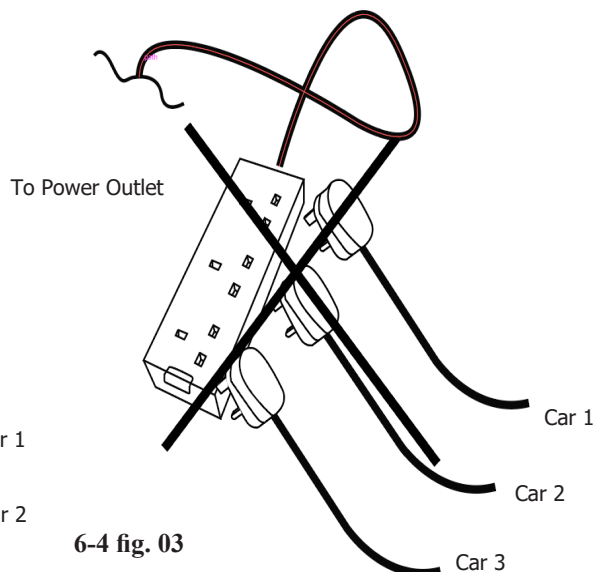

6-4 fig. 03

6-5 LINKING THE CABINETS (COMMUNICATION)

When installing two or more cabinets, it is recommended that they be linked together via a Network cable (supplied) to encourage multiple play, whereby players race together in the same race. Note: The provided LAN cable will connect two cabinets only. To connect 3 or more cabinets, a network switch and multiple LAN cables are required. A network switch is not included in the installation kit but can be purchased through Sega on request.

STOP IMPORTANT

When powering the machine on for the first time, be sure NOT to have the network cables connected. Having the network cables connected when powering up for the first time will cause a network malfunction and incorrect IP addresses will be assigned.

- 1 Make sure the ASSY BILLBOARD is fitted and all connections made (see the beginning of this chapter)
- 2 Apply power to the cabinet and enter the TEST menu using the TEST SW located behind the coin door on the credit board
- 3 Select NETWORK SETTINGS > CABINET ID. Assign ID 1 to the first cabinet, ID 2 to the second cabinet and so on
- 4 Select NETWORK SETTINGS > TOTAL LINKED CABINETS. Assign the number of total cabinets to be linked in the network
- 5 Confirm changes. The Game BD and BILLBOARD will reboot. Repeat steps 1 to 5 until all cabinets within the network are assigned identification
- 6 Using the LAN Cable (supplied), connect each cabinet network port situated on the AC Bracket together. The example below shows a typical set up. To connect 3 or more cabinets using a network switch (sold separately), see 6-5 Fig 2 & 3. A maximum of 8 cabinets can be linked together

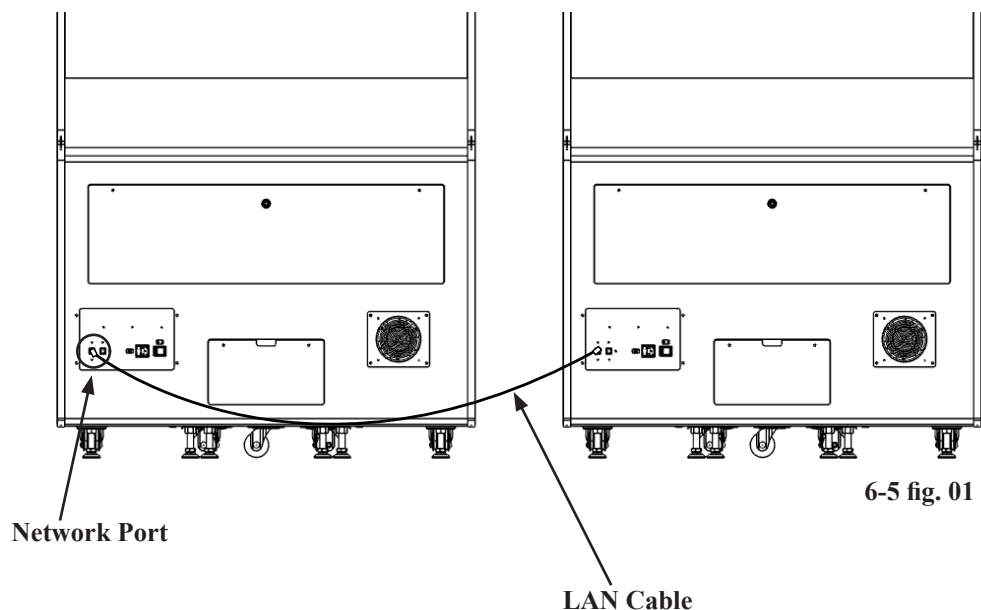

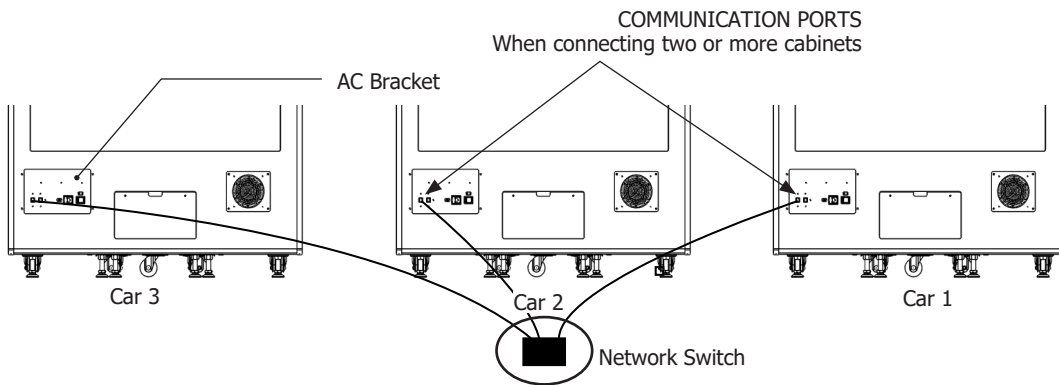

6-5 fig. 02

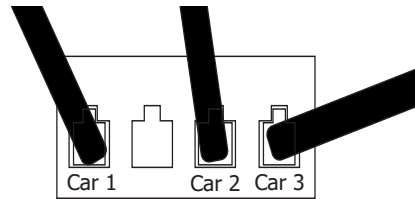

6-5 fig. 03

6-6 APPLYING POWER

STOP IMPORTANT

Each cabinet has its own dedicated mains power input. Only use the power leads supplied with this machine. **DO NOT** connect more than 2 units in any one extension power lead. Using power leads not supplied with this product may cause an overload situation resulting in overheating, power failure or possibly fire hazard.

⚠ WARNING

- Use the power supply equipped with an earth leakage breaker. Use of power supply without such a breaker could result in fire if there is a current leakage.
- Do not expose the power cord or ground wire. If these are exposed, customers could stumble over them, for instance, and easily damage them. Additionally, if these lines are damaged, there could be a risk of electrical shock or short circuit. Set these lines at locations where they will not interfere with customer traffic, or attach covers to them.
- After laying out the power cord on the floor, be sure to always protect it. If the power cord is left exposed, it can easily be damaged, resulting in electrical shock.
- This product must only be used within the countries that it has been designed for. If the information within this section does not appear to match your electrical requirements then please contact the offices where purchased before applying power.

! WARNING

- Proceed with checks and tasks as indicated in these instructions. If instructions are not followed, or if tasks and/or checks are neglected, an electric shock or other very serious accident, even fatal accident, can occur. Also, customers could be injured while operating the product.
- For safe operation, inspect and check the operation of each part of the product when turning on the power. If any defects are found, deal with them immediately. Never operate the product with defects still present.

The AC units are attached to the rear of the ASSY MONITOR CABINET.

- Main switch
- Inlet for power cable connection
- Network (RJ45) for communication play.
- Fuses and fuse holder

1 Confirm that the main switch is at OFF.

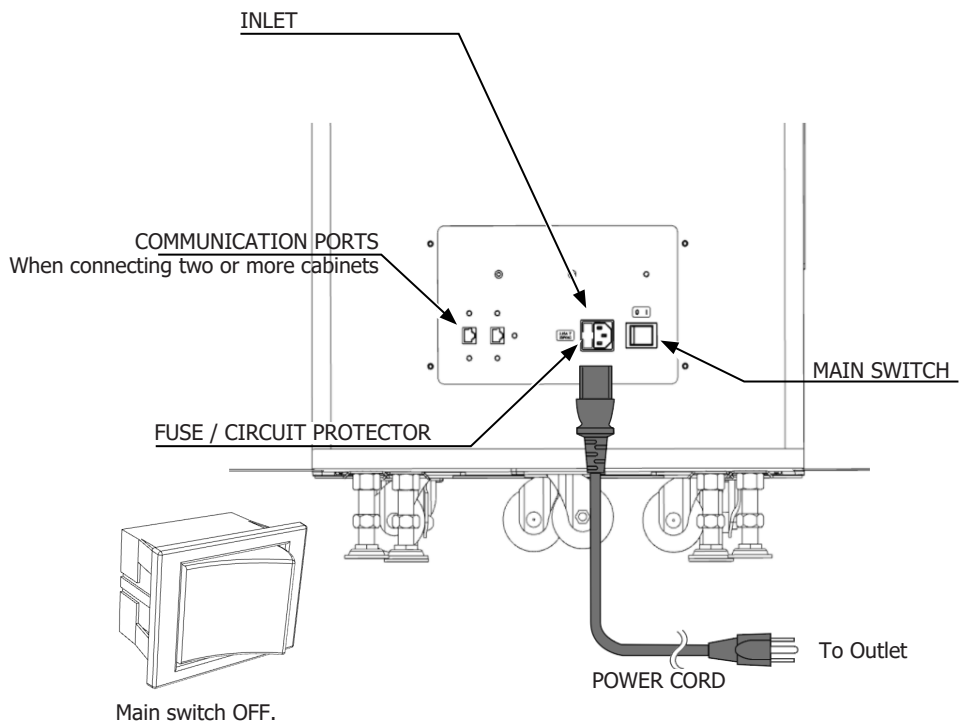

6-6 fig. 01

2 Fully insert the power cord connector on the side opposite the power plug into the AC unit inlet.

3 The power cord is laid out indoors. Protect the power cord by attaching wire cover to it. If ground will be established with a ground wire made available separately, lay out the ground wire indoors and have it protected.

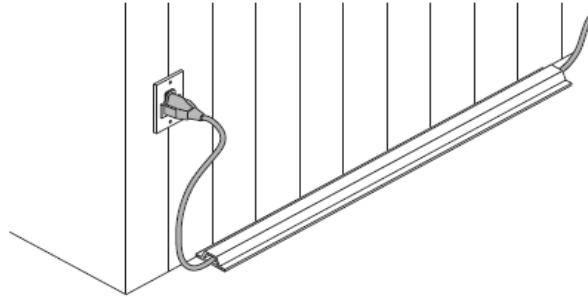

6-6 fig. 02

STOP IMPORTANT

After starting the initialization operation, wait until the advertising screen is displayed or until an error screen is displayed due to the detection of an error. If switches, etc. are inadvertently operated, faults or parts damage may occur.

1 Reinspect the assembly work, paying special attention to the points below. Finally, check that there are no persons near the cabinet. Have all the adjusters been properly grounded, and are no casters contacting the floor surface? Have all power cables been connected correctly? Have the covers/doors been refitted to the cabinet? Have all fastening bolts and screws been tightened? Have any foreign objects been placed near the seat, or have any tools or spare screws, etc. been left on or in the product? Have any foreign objects been placed near the steering wheel?

2 Turn the main switch, located on the rear of the cockpit ON. This sends power throughout the product. Following the order below, output locations will activate. 1) WINDOWS/SEGA logo is displayed on LCD screen. 2) Steering Wheel calibrates - moves fully left/right then returns to the centre position. 3) Inter-cabinet communication check (in case of communication connection setting). 4) The Game loading Screen appears on screen. 5) Game attract sequence begins

3 If (after the initialization operation ends) the steering wheel is not at its center position (facing straight ahead) for example, re-engage the power and conduct the initialization operation again. If the problem is not corrected after repeating the initialization, there is most likely a fault in the volume settings. Enter Test Mode, and check the settings. For this product, the following data and settings are still saved even if the power is turned off. Coin numbers represented in fractions (number of coins deposited that are not enough for one credit) and bonus adder count data are not saved.

4 Once the machine has initialised, enter the TEST screen by engaging the TEST button.

5 Carry out a routine check to make sure all INPUTS/OUTPUTS are functioning correctly. Please refer to section 9 of this manual for information on the I/O tests and functionality.

7 PRECAUTIONS WHEN MOVING

WARNING

- As used in these instructions, the term “moving” refers to moving of the product within the same building, store or facility. These instructions do not cover moving between different buildings, areas, stores or facilities, since diverse factors are involved, not only packaging but also loading onto transport vehicles and securing the product in place during transport. To transport the product to a different building or store, contact the vendor where the product was purchased, the office indicated in these instructions, or request that the moving be done for you. This product is made up of parts that are of large size and heavy weight. Unless work is entrusted to someone with expertise in packaging and transport of such parts, a serious accident might occur.
- Even when the product is to be moved within the same building, store or facility, contact the point of purchase or the office indicated in these instructions if there will be level differences and/or narrow or low level entrances while moving. Alternatively, request that moving be done for you. Never disassemble the product in any way not covered in these instructions as this could cause fire, electric shock and/or short circuit.
- Always disconnect the power cable before moving the product. If it is moved with the power cable connected, the cable could be damaged, causing fire or electric shock.
- A qualified electrician is required for moving product parts within a store and for changing indoor wiring. Do not have work performed by anyone who is not qualified, otherwise there could be electric shock.
- Have work performed by site maintenance personnel or other qualified individuals. Do not allow people without proper knowledge and technical expertise to work on the product as this could cause electric shock or other serious accident. Also, customers could be injured while operating the product.
- Proceed with checks and tasks as indicated in these instructions. If instructions are not followed or if tasks and/or checks are neglected, an electric shock, serious, or fatal accident can occur. Also, customers could be injured while operating the product.
- Be careful not to damage wiring. Before separating parts that have wiring connections, disconnect the wiring connections, unravel wire bundles and undo fastenings. Only after that, remove fasteners (screws, nuts, etc.). If wiring becomes damaged, there could be an electric shock, short circuit or fire.

7-1 MOVING THE MACHINE

WARNING

- Always disconnect the power cable before moving the product. If it is moved with the power cable connected, the cable could be damaged, causing fire or electric shock.
- To move the unit over the floor, pull in the adjustors and have the casters contact the floor. While moving the unit, be careful that the casters do not roll over the power cord or the ground wire. If cord or wire is damaged, there could be electrical shocks and/or short circuits.
- When crossing a sloped or stepped area, disconnect the Main Cabinet and Seat Cabinet. If you tilt them while connected together, the connection points may be damaged and personnel could be injured.
- When lifting the Cabinet up steps, it must be held by the designated handles or by the bottom surface. Lifting it by any other area may lead to damage or disfiguring that part or surrounding parts due to the weight of the cabinet and could also lead to injury of personnel.
- When tilting the cabinet to move it across a sloped or stepped area, always use at least two people. Attempting such an operation alone can lead to accident or injury.
- Do not press the LED screen. The screen can be easily damaged and cannot be repaired if it is, meaning complete replacement will be necessary.

CAUTION

- When moving the components, do not push any of the plastic elements, shaped parts or use them to pull the components along. This may damage the parts or the surrounding parts and this could lead to accidents or injury.
- Do not use the Control Units on the Main Cabinet to push or pull the cabinet. This may damage or disfigure these parts and lead to malfunctions or injury.
- When moving the cabinet, be sure to push/pull each cabinet lengthways. Trying to move the cabinet any other way may cause the cabinet to topple over.

CAUTION

- To work safely and precisely prepare a steady, safety stool or ladder to stand on. Climbing onto the cabinet or hanging down from it can lead to accidents.

STOP IMPORTANT

- If you need to move components through a narrow or low door and the only way to get the separated components through is to turn them on their side (or if a separation method other than those described in this manual is required), either make a request to the office listed in this document or the place of purchase to perform the operation or contact them regarding how to perform it. Carelessly turning the components onto their side or separating them in ways other than those depicted in this manual may lead to irreparable damage.

The machine can be moved over short distances within the same environment without the need to disassemble. However, when transporting the machine to a different location it is advised that the machine be disassembled into two individual components. These components are the (1) Display Cabinet Assembly and (2) Seat Cabinet Assembly.

For a detailed instruction on how to disassembly the machine into these 2 parts, please refer to Chapter 6 in this manual and follow the instructions of "Installation" in reverse order.

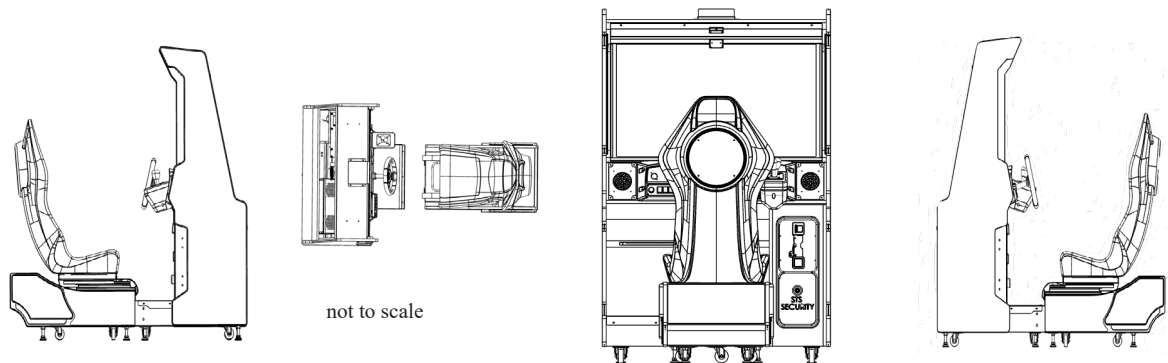

7-1 fig. 01

STOP IMPORTANT

- When relocating the machine to a different area within the same environment, be sure to raise all leg adjusters. Failing to fully raise all leg adjusters may cause them to hit the ground and become damaged. If the leg adjusters become damaged, replace them immediately. Do not locate the machine using damaged leg adjusters. Locating the machine using damaged leg adjusters will make the product unstable.

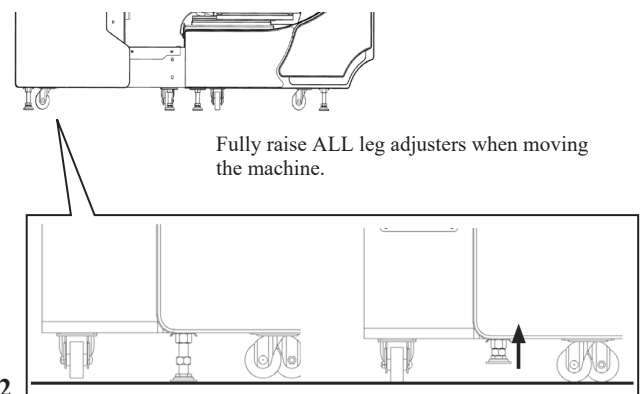

7-1 fig. 02

8 GAME DESCRIPTION

DAYTONA CHAMPIONSHIP USA

Daytona Championship USA is the latest racing game from legendary arcade machine manufacturer Sega Amusements. *Daytona Championship USA* is a reimagining of the classic arcade racing hit, *Daytona USA*. This new release contains 6 action packed tracks; 3 brand new courses accompanied by 3 beautifully redesigned classic tracks from the original game. Players will race against the computer and up to 7 other real players, with the new billboard system allowing drivers to see their competitors' reactions in real time. With improved handling, updated graphical designs, and challenging gameplay, *Daytona Championship USA* is the return of the titan of arcade racing.

MULTIPLAYER LOBBY (LINKED CABINETS)

WHEN THE MACHINE IS IN CREDIT AND THE START BUTTON IS PRESSED, THE FOLLOWING SCREEN IS DISPLAYED, INDICATING THE GAME PLAY AVAILABLE.

The first action for the player is to select whether to enter into a Multiplayer or Single Player game. When connected, the player will automatically be entered in to a Multiplayer lobby, at which point any connected cabinets can join. To enter a Single Player game by themselves, a player must hold the START button and press down on the accelerator. If the timer expires and no other players have entered the lobby, the game will automatically enter a Single Player lobby.



Single Player

If the player inserts a credit when a cabinet is not linked to any other machines (or if no other players join the lobby) and then presses the Start button, they will be taken in to a Single Player game where they are given the option between QUICK RACE, CHAMPIONSHIP* and TOURNAMENT* (*if enabled in the Game Settings of the Test & Service menu).



To make a selection, the player must turn the steering wheel left and right to highlight an option and press the accelerator to confirm their choice.

During this selection process, a countdown is displayed in the top right hand corner of the screen. If the player does not make a selection within this time, Quick Race will be selected.

Quick Race

This game mode is available in Single and Multiplayer. It allows all 6 tracks to be played in either standard or time lap mode.



Standard Quick Race

On the transmission screen, the player will be able to choose from standard quick race against AI players or compete in time lap mode.



Quick Race is the default race type. To select time lap mode, the player must hold the start button and press down on the accelerator pedal when selecting transmission type (this is also detailed on the screen itself).



Standard Quick Race is against a number of AI racers. The race will finish regardless of where the player finishes or if the timer expires.

Time Lap Mode

Time Lap mode is available in Single Player only. In this mode, only the player will be racing around the track, competing to set the fastest possible lap time.



The player must reach checkpoints to extend the timer. If the player does not reach a checkpoint in time, the race will end.



If the player receives a high score upon completing the track, they will be prompted to enter a three letter name at the name entry screen. This will then be displayed on the attract menu when the high scores for the relevant tracks are shown.



The player turns the steering wheel left and right to highlight a letter and selects their choice by pressing down on the accelerator. During this time, a countdown timer will appear in the top right hand corner. If no name is selected before the timer reaches zero or if the START button is pressed, the game will generate a three letter name for the player.



Championship

This game mode is available in Single Player only. It challenges the player to three races, one beginner track, one advanced track, and one expert track. The goal of this game mode is to place in one of the top three positions to advance to the next race. If the player fails, they can insert a credit to retry the current race they are on* (*if 'CHAMPIONSHIP CONTINUE' is set to 'YES' in the 'GAME SETTINGS').



If the player receives a high score upon completing the third track, they will be prompted to enter their name at the name entry screen. This will then be displayed on the attract menu high score table.



Tournament

Tournament is a specific mode that allows the operator to create a time limited event that will run between 1 and 30 days. During the selected time period, players compete for the fastest time on a track determined by the operator in the test menu.



When enabled, tournament provides its own high score table with time and date stamps. These scores remain on display after the event has expired. Until tournament is turned off in the test menu, the high score table will continue to be displayed.

See the Test and Service Menu section for more details on how to set up Tournament mode.

Track Select

If a player selects Quick Race in Single Player, the track select screen will then be displayed.



To select a track, the steering wheel must be turned left or right and the accelerator pressed down to confirm. The player can choose from six tracks:

| | |
|---------------------------------|----------|
| Daytona International Speedway | Beginner |
| Three-seven Speedway (Classic) | Beginner |
| Lakeside Castle | Advanced |
| Dinosaur Canyon (Classic) | Advanced |
| Metro City | Expert |
| Seaside Street Galaxy (Classic) | Expert |

The difficulty of each track is labelled on the select screen. During this time, a countdown timer will appear in the top right hand corner. If no track is selected before the timer reaches zero, the track that is currently highlighted by the player will be selected.

Transmission/Car Select

After selecting a track, the player will be prompted to select either automatic or manual transmission.

Automatic is recommended for new players. In this transmission, the player will not be required to change gears as it will be done for them.



Manual transmission is recommended for more experienced players. This will require the player to change the gears themselves.

During this time, a countdown timer will appear in the top right hand corner. If no car transmission is selected before the timer reaches zero, automatic transmission will be chosen.



From here, the player will enter the track preview screen, after which the race will begin.



Multiplayer

Multiplayer Track Select

After all players have entered the lobby, the track select screen will be shown allowing players to vote on what track they wish to race on. The track with the most votes will be selected.

During this time, a countdown timer will appear in the top right hand corner. If no track is selected before the timer reaches zero, the track that is currently highlighted by the player will be chosen automatically.

If the votes are tied, the track that is the easiest difficulty will be selected.



Multiplayer Transmission Select

After selecting a track, the player will be prompted to select either automatic or manual transmission.

Automatic is recommended for new players. In this transmission, the player will not be required to change gears as it will be done for them.

Manual transmission is recommended for more experienced players. This will require the player to change the gears themselves.

During this time, a countdown timer will appear in the top right hand corner. If no car transmission is selected before the timer reaches zero, automatic transmission will be chosen.

Real Racers Only

This option is only available in multiplayer. This determines whether the AI will be in the race with the players. To initiate Real Racers Only, the players must hold the start button while selecting car transmission. Real racers on or off is determined by the players voting. The majority option will be chosen.

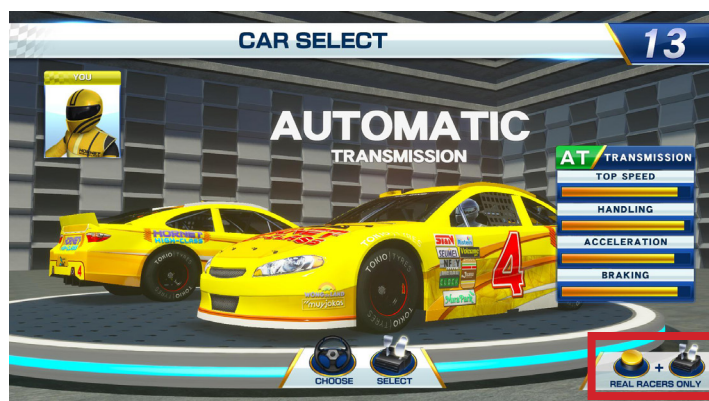

HUD (Heads up Display)

The image below represents the standard HUD screen in a single player race. It displays:



- | | |
|-----------------------------|--|
| 1 - LAP NUMBER | Indicates the current lap the player is on and how many laps the race is in total |
| 2 - LAP TIME COUNTER | Indicates the current lap time as well as any previous lap times |
| 3 - TIMER | Indicates how much time the player has to reach the next checkpoint. If the timer reaches zero, the race will end |
| 4 - RACE POSITION | Indicates the current ranking of the player in the race (e.g. 10th out of 20 racers) |
| 5 - MINI-MAP | This displays a section of the map surrounding the player. The player car is shown as a blue arrow, with other players/AI racers as red arrows. Checkpoint markers are denoted with a black line |
| 6 - SPEEDOMETER | Indicates the speed the player is currently travelling at. If in manual transmission, this displays the gear the player is in |
| 7 - RACE BANNER | This indicates what car is in what position in the race. This is displayed in a scrolling style from right to left |

Single Player Time Lap HUD

The Time Lap mode HUD contains all the elements of the standard HUD with some other included features:

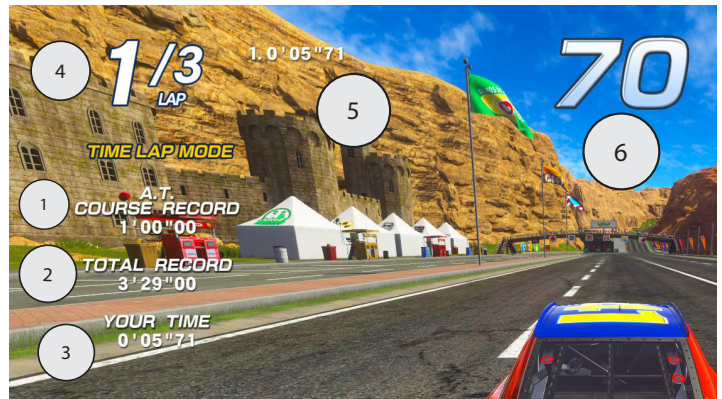

1 - COURSE RECORD TIME

This displays the current record time for a single lap. There are separate record times for Automatic and Manual transmissions

2 - TOTAL RECORD TIME

This displays the player's current best time for the entire track

3 - YOUR TIME

This displays the player's current lap time

4 - LAP NUMBER

Indicates the current lap the player is on and how many laps the race is in total

5 - LAP TIME COUNTER

Indicates the current lap time as well as any previous lap times

6 - TIMER

Indicates how much time the player has to reach the next checkpoint. If the timer reaches zero, the race will end

Player Views

Players can select from one of four views. These views can be selected by pressing the different view buttons on the cabinet. The views are labelled and shown below:

View 1



View 2



View 3



View 4



9 EXPLANATION OF TEST AND DATA DISPLAY

Perform tests and data checks periodically by manipulating the TEST Button and SERVICE Button in the cabinet. Follow the instructions in this chapter to conduct checks when the game machine is first installed, when money is being collected, or when the game machine does not operate properly.

Shown overleaf are the tests and screens to be used for different problems.

WARNING

When installing 2 or more cabinets which are networked together, the **GAME SETTINGS** which are adjusted within the first cabinet are reflected throughout all cabinets within that network.

IMPORTANT

When changing the game configuration within the **TEST MODE**, be sure to exit all screens in the correct manner by choosing exit. **DO NOT** turn the machine **ON/OFF** to resume game. Changes **WILL NOT** take effect unless the correct method is used.

9-1 SWITCH UNIT

WARNING

Never touch places other than those specified. Touching places not specified can cause electric shock and short circuit accidents.

IMPORTANT

Adjust the sound to the optimum volume, taking into consideration the environmental requirements of the installation location.

Removing the Coin Meter circuitry renders the game inoperable.

SWITCH UNIT

Open the service panel and the switch unit shown will appear.
The functioning of each SW is as follows:

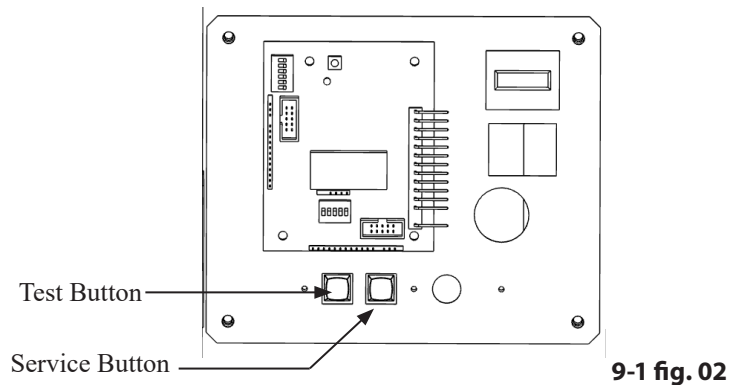
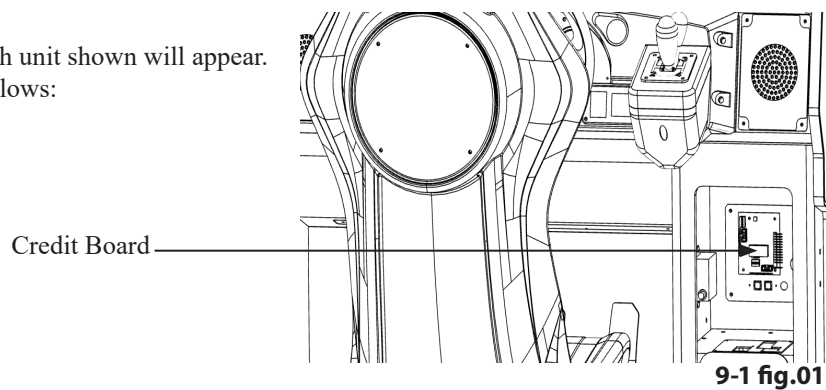

| | |
|---------------------------|--|
| TEST Button (TEST): | For the handling of the Test Button, refer to the following pages. |
| SERVICE Button (SERVICE): | Gives credits without registering on the coin meter. |

9-2 TEST MODE

STOP IMPORTANT

- The details of changes to Test Mode settings are saved when you exit from Test Mode by selecting EXIT from the System Test Mode Menu. If power is turned off before that point, changes to the settings will be lost.
- Entering the Test Mode clears fractional number of coins less than one credit and bonus adder data.
- Use with the specified settings. If settings other than those specified are used, inappropriate operations or malfunction may occur.

Test & Service Menu

The Test Menu is the area where you can perform a variety of tests and change numerous settings to best suit the customers' needs and those of your business. It also stores and contains data that will allow you to see when it is most popular, set up tournaments and check and troubleshoot any errors. The TEST button and the SERVICE buttons control navigation of the menu system.

The following options are available from the Test Menu:

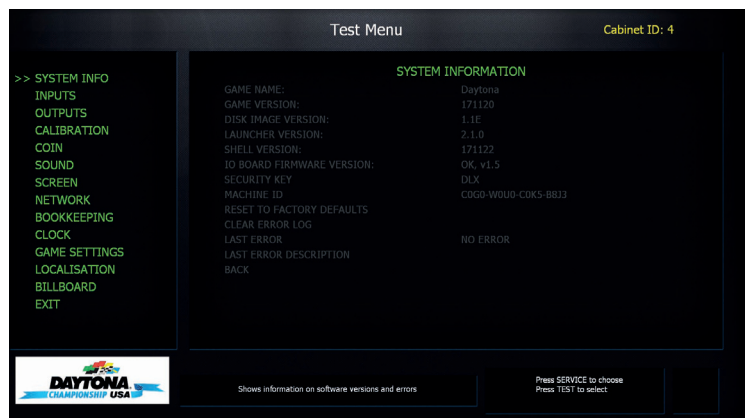

9-2 fig.01

The user will use the SERVICE button to select the desired test and the TEST button to activate the test in the left hand pane of the display.

SYSTEM INFORMATION:

INPUTS:

OUTPUTS:

CALIBRATION:

COIN:

SOUND:

SCREEN:

NETWORK:

BOOKKEEPING:

CLOCK:

GAME SETTINGS:

LOCALISATION:

BILLBOARD:

EXIT:

General Information on installed software and hardware

Test routine for input peripherals

Test routine for output peripherals

Calibration routines for input peripherals

Test routine for coin handling

Test routine for audio outputs

Test routine for display screen

Test routine for Ethernet link

System meters and bookkeeping

System clock setting

Test routine for Game Specific settings

Routine to change in game languages

Test routine for Video Billboard (If fitted)

Leave System Menu and launch game

STOP IMPORTANT

- When changing the game configuration within the TEST MODE, be sure to exit all screens in the correct manner by choosing exit. DO NOT turn the machine ON/OFF to resume game. Changes WILL NOT take effect unless the correct method is used.

System Information

Select 'System Information' from the Test Menu to display the System Information menu. This test displays general system information regarding the hardware configuration and installed software.

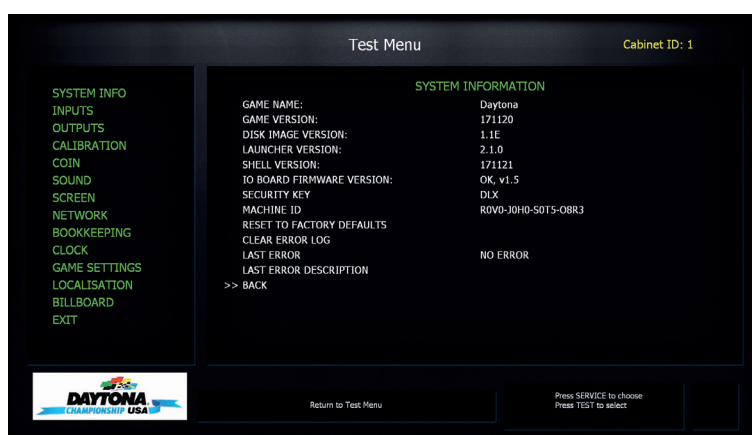

9-2 fig.02

| | |
|-----------------------------------|---|
| GAME NAME: | Name of the installed game. |
| GAME VERSION: | Version number of installed game. |
| DISK IMAGE VERSION: | Version number for master disk image. |
| LAUNCHER VERSION: | Version number for System Launcher. |
| SHELL VERSION: | Version number for Shell. |
| IO BOARD F/W VERSION: | Displays I/O Board Firmware Revision if valid IO Board is fitted, otherwise displays FAILED . |
| SECURITY KEY: | Displays Security Key Data or if not present NOT FITTED . |
| MACHINE ID: | Displays unique machine ID or UNKNOWN SECURITY KEY . |
| RESET TO FACTORY DEFAULTS: | If Test is pressed when this item is highlighted then all settings are returned to factory defaults and the cabinet will restart (Requires confirmation). |
| CLEAR ERROR LOG: | Clears all recorded errors. |
| LAST ERROR: | Displays Last recorded error with Time & Date stamp or NO ERRORS. Pressing Test whilst over this item scrolls through the last 10 errors. |
| LAST ERROR: | Displays Verbose description of current error and troubleshooting advice . |
| BACK: | Exit this test and return to Test & Service Menu. |

Inputs

Select 'Input Test' from the Test Menu to display the Input Test menu. This test is used to test system inputs such as steering wheels, pedals and switches.

To implement the test, press each device that is listed and check the results on screen.

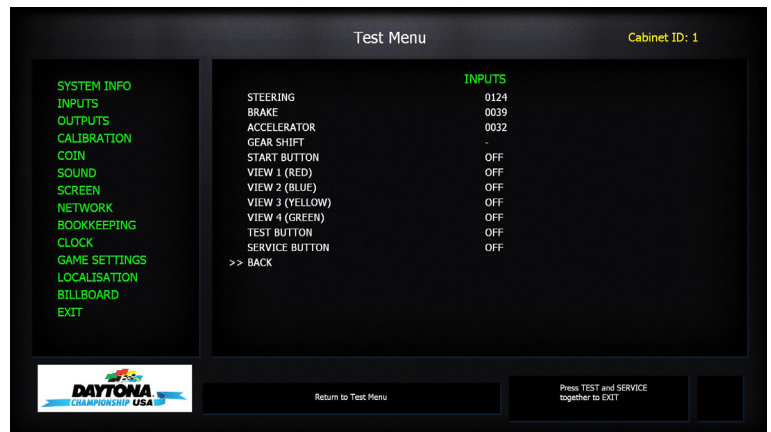

9-2 fig. 03

| | |
|------------------------|---|
| STEERING: | 0-255 Maximum range |
| BRAKE: | 0-255 Maximum range |
| ACCELERATOR: | 0-255 Maximum range |
| GEAR SHIFT: | - (not in use), UP, DOWN, 1,2,3,4 |
| START BUTTON: | ON = pressed, OFF = not pressed |
| VIEW 1: | ON = pressed, OFF = not pressed |
| VIEW 2: | ON = pressed, OFF = not pressed |
| VIEW 3: | ON = pressed, OFF = not pressed |
| VIEW 4: | ON = pressed, OFF = not pressed |
| TEST: | ON = pressed, OFF = not pressed |
| SERVICE BUTTON: | ON = pressed, OFF = not pressed |
| EXIT: | Press TEST and Service simultaneously to exit |

To exit this menu you must press the TEST and SERVICE buttons simultaneously.

Outputs

Select 'OUTPUT TEST' from the Game Test menu to display the Output Test Menu. This test is used to test system outputs such as lamps or actuators.

Press the SERVICE button to move the cursor to the desired test item.

Press the TEST button to test the selected item.

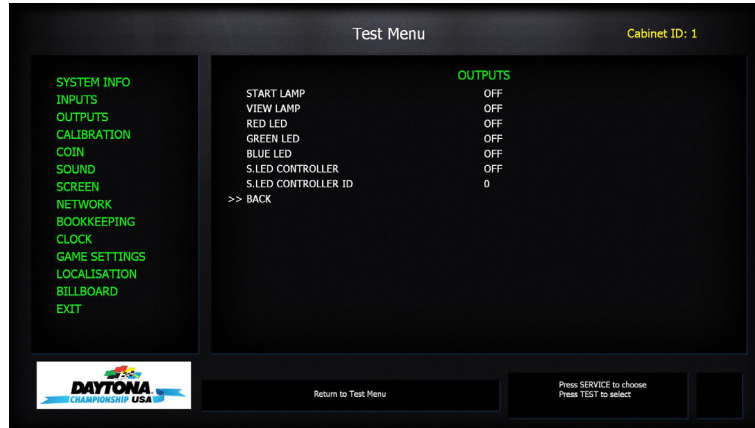

9-2 fig.04

| | |
|-----------------------------|--|
| START LAMP: | ON = Lamp ON, OFF = Lamp OFF |
| VIEW LAMP: | ON = Lamp ON, OFF = Lamp OFF |
| RED LED: | ON = Lamp ON, OFF = Lamp OFF |
| GREEN LED: | ON = Lamp ON, OFF = Lamp OFF |
| BLUE LED: | ON = Lamp ON, OFF = Lamp OFF |
| S.LED CONTROLLER: | OFF = OFF, ATTRACT, IN GAME, RACE LEADER, CRASH, OVERTAKE = Test lighting animation |
| S.LED CONTROLLER ID: | Test Lighting routine specific to cabinet ID |
| BACK: | Exit this test and return to Test & Service Menu |

Please note that turning on more than one LED will change the colour accordingly:

| | |
|----------------------|-----------------------|
| RED and GREEN: | Panel will be YELLOW |
| RED and BLUE: | Panel will be MAGENTA |
| GREEN and BLUE: | Panel will be CYAN |
| RED, GREEN and BLUE: | Panel will be WHITE |

The user will use the SERVICE button to select the desired output and the TEST button to change the output status.

EXIT: This will exit the menu and turn all lamps and LED's off.

Move the cursor to EXIT and press the TEST button to return to the TEST MENU screen.

Calibration

Select 'Calibration Test' from the Test Menu screen to display the Calibration Test menu.

This test is used to calibrate analogue inputs and to test and set steering force feedback. Use the SERVICE button to move the cursor to the desired test item. Press the TEST button to enter the selected item.

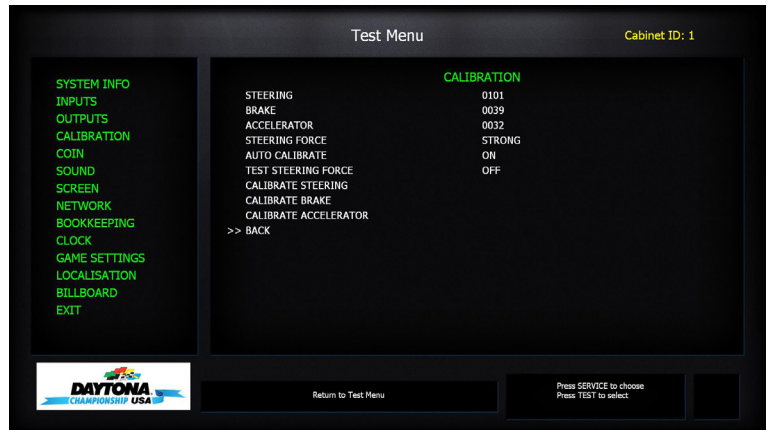

9-2 fig. 05

- STEERING:** This displays the current Calibration setting for the steering wheel.
Current input value (0-255)
- BRAKE:** This displays the current Calibration setting for the Brake Pedal.
Current input value (0-255)
- ACCELERATOR:** This displays the current Calibration setting for the Accelerator Pedal.
Current input value (0-255)
- STEERING FORCE:** This sets the amount of force feedback used in the steering wheel when playing the game. There are four options available:
OFF – No steering force will be used
WEAK – Minimal steering force will be used
NORMAL – Normal steering force will be used
STRONG – Maximum steering force will be used
- AUTO CALIBRATE:** **ON/OFF** Enables or disables automated calibration of steering at start up.
- TEST STEERING FORCE:** This will give an indication of what the currently selected Steering Force is like by automatically turning the wheel to a full lock in each direction.

NOTE: If STEERING FORCE is set to **OFF**, selecting TEST STEERING FORCE will not move the steering wheel.

- CALIBRATE STEERING*** Launches Calibration routine
- CALIBRATE BRAKE*** Launches Calibration routine
- CALIBRATE ACCELERATOR*** Launches Calibration routine

CALIBRATE STEERING ROUTINE*

Starts the steering calibration routine. The wheel will automatically be calibrated by turning full left and then full right. No input is needed from the user once the test has been started. If Auto Calibration has been disabled please follow the on-screen instructions to manually calibrate

CALIBRATE BRAKE ROUTINE*

Starts the brake calibration routine. The user must follow the on screen prompts to fully depress and then release the brake pedal for 5 seconds.

CALIBRATE ACCELERATOR ROUTINE*

Starts the accelerator calibration routine. The user must follow the on screen prompts to fully depress and then release the accelerator pedal for 5 seconds.

- BACK** Exit this test and return to Test & Service Menu

Coin Settings

This part of the test menu is used to set credit related parameters. Select COIN from the Test menu to display the Coin Settings Menu.

Use the SERVICE button to move the cursor to the desired test item.
Press the TEST button to enter the selected item.

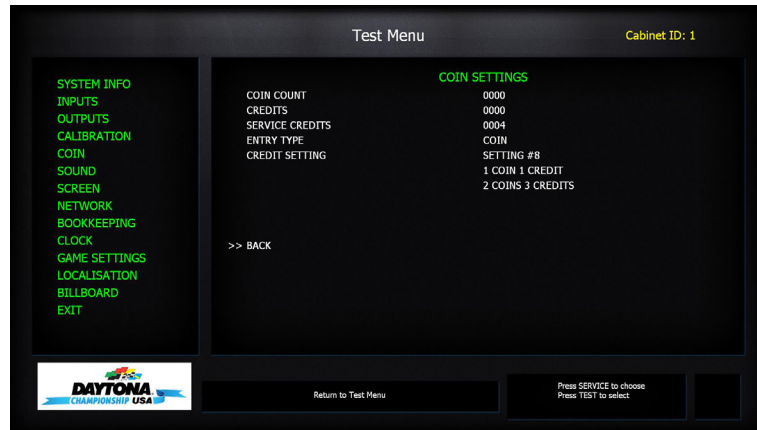

9-2 fig.06

This text displays the accumulative coins and credits values. Freeplay can be turned on/off by cycling through the Credit Settings options.

COIN COUNT: Coin count value from I/O board (cannot be reset)
CREDITS: Total number of credits added to system
SERVICE CREDITS: Total number of Service credits added to system
ENTRY TYPE: Payment Method (COIN*\CARD\ SWIPE)
COIN SETTING: The following coin settings are available:

| | |
|----|---|
| 1 | 1 COIN 1 CREDIT |
| 2 | 1 COIN 2 CREDITS |
| 3 | 1 COIN 3 CREDITS |
| 4 | 1 COIN 4 CREDITS |
| 5 | 1 COIN 5 CREDITS |
| 6 | 1 COIN 6 CREDITS |
| 7 | 2 COINS 1 CREDIT |
| 8 | 1 COIN 1 CREDIT, 2 COINS 3 CREDITS |
| 9 | 3 COINS 1 CREDIT |
| 10 | 4 COINS 1 CREDIT |
| 11 | 1 COIN 1 CREDIT, 2 COINS 2 CREDITS, 3 COINS 3 CREDITS, 4 COINS 5 CREDITS |
| 12 | 5 COINS 1 CREDIT |
| 13 | 3 COINS 1 CREDIT, 5 COINS 2 CREDITS |
| 14 | 2 COINS 1 CREDIT, 4 COINS 2 CREDITS, 5 COINS 3 CREDITS |
| 15 | 1 COIN 1 CREDIT, 2 COINS 2 CREDITS, 3 COINS 3 CREDITS, 4 COINS 4 CREDITS, 5 COINS 6 CREDITS |
| 16 | FREEPLAY |

BACK: Exit this test and return to Test & Service Menu. This will save any changes to freeplay on this cabinet only.

Use the TEST button on the EXIT option to return to the System Menu.

Sound Settings

This test is used to set audio levels for the game and to test function of the speaker system. Select ‘Sound Settings’ from the test menu to display the Sound Settings Menu.

Use the SERVICE button to move the cursor to the desired test item.
Press the TEST button to enter the selected item.

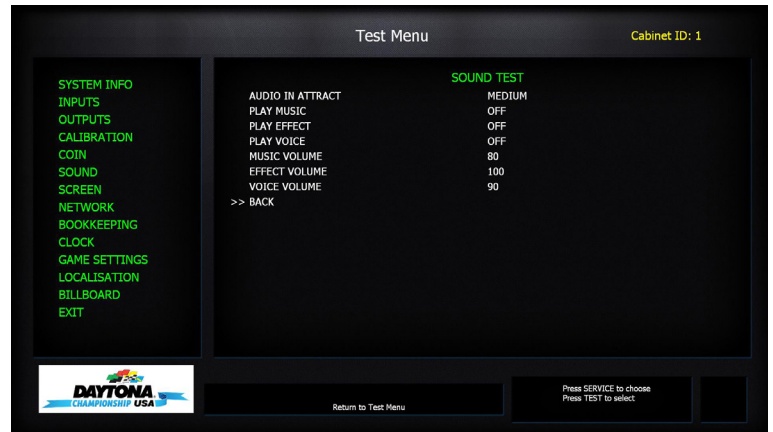

9-2 fig. 07

| | |
|-------------------------|---|
| AUDIO IN ATTRACT | Volume in attract mode (OFF/LOW/MEDIUM*/HIGH) |
| PLAY MUSIC | Play a sample of game music |
| PLAY EFFECT | Play a sample of game sound effects |
| PLAY VOICE | Play a sample of game voice |
| MUSIC VOLUME | Game Music level 00 to 100 (Default 100) |
| EFFECT VOLUME | Game Sound Effect level 00 to 100 (Default 100) |
| VOICE VOLUME | Game Voice level 00 to 100 (Default 100) |

* Denotes default values

The user will use the SERVICE button to select the desired test and the TEST button to activate the test. Move the cursor to BACK and press the TEST button to return to the Test Menu screen.

Screen

This test is used to test the game display is working correctly.

Use the SERVICE button to move the cursor to the desired test item.
Press the TEST button to enter the selected item.

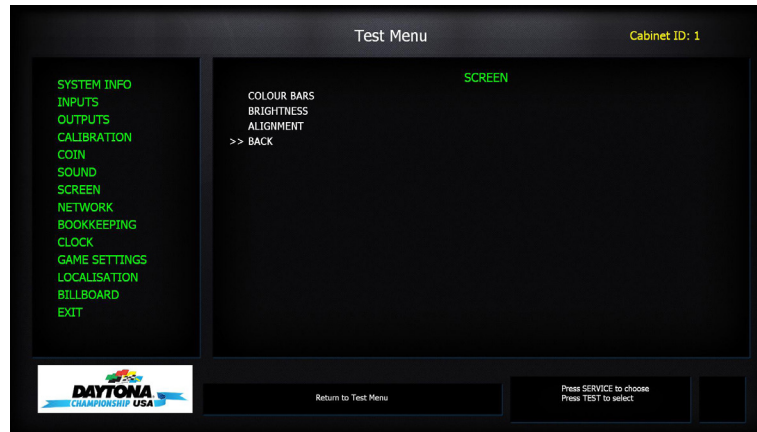

9-2 fig. 08

Colour Bars:

Selecting this will display the following screen.

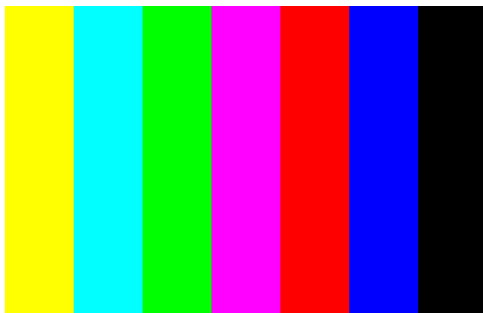

9-2 fig. 09

Brightness:

Selecting this will display the following screen.



9-2 fig. 10

Grid Alignment:

Selecting this will display the following screen.

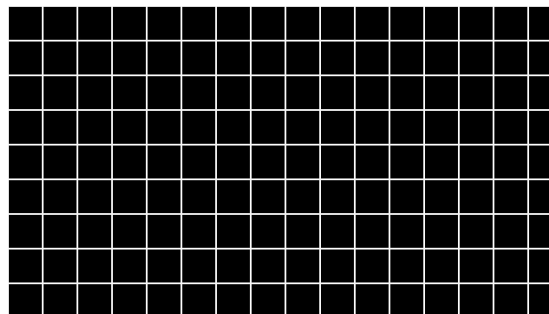

9-2 fig. 11

Network Test

This test is used to test the network link between cabinets (if connected). Select 'NETWORK' from the Test menu to display the Network Test Menu.

IMPORTANT NOTES:

In any cabinet configuration one cabinet must be set to ID=1, this is the Server that will control the network operation.

When making changes to "Cabinet ID" the cabinet should not be networked to any other cabinets.

Once Changes are made "CONFIRM CHANGES" must be selected to commit the change and restart the cabinet.

Use the SERVICE button to move the cursor to the desired test item.

Press the TEST button to enter the selected item.

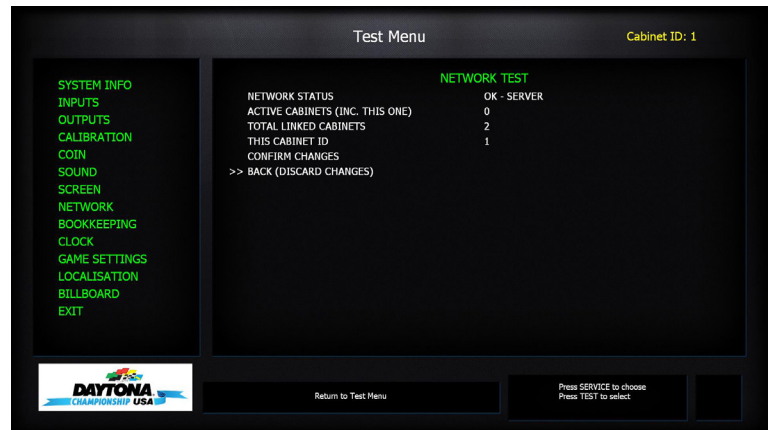

9-2 fig . 12

NETWORK STATUS:

OK SERVER = Connected as server. OK CLIENT = Connected as client

ACTIVE CABINETS

(INC THIS ONE):

The total number of cabinets connected or UNKNOWN

TOTAL LINKED CABINETS:

The total number of cabinets networked together. Must be set identically on all connected cabinets. If this value is changed, the user must use CONFIRM CHANGES and the cabinet will restart.

CABINET ID:

ID of cabinet from 1 to 8. If this value is changed, the user must use CONFIRM CHANGES and the cabinet will restart.

CONFIRM CHANGES:

The user will be prompted to press TEST again to confirm. If the user presses TEST again, the action is confirmed and the Cab will reset. If the user presses SERVICE the action is aborted and settings discarded.

BACK

Exit this test and return to Test & Service Menu

Move the cursor to BACK and press the TEST button to return to the Test Menu screen.

Bookkeeping – Screen 1

This test is used to review statistical data from the system. It consists of 7 screens of data. Screen 1 contains an overview of game play data. Select 'BOOKKEEPING' from the Test menu to display the Bookkeeping Test Menu.

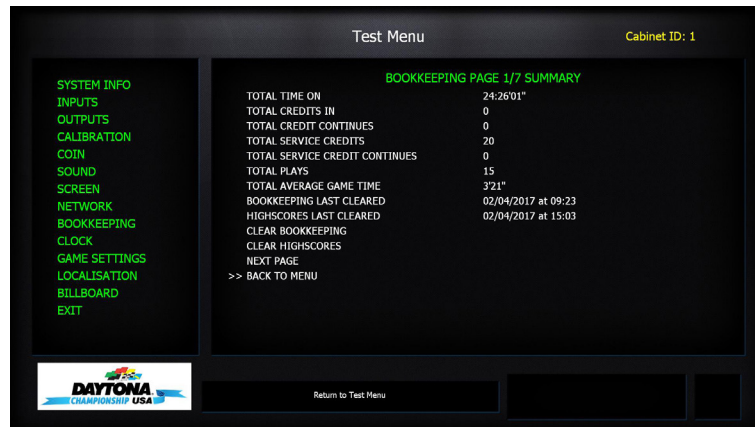

9-2 fig. 13

| | |
|----------------------------------|--|
| TOTAL TIME ON: | The total time the cabinet has been switched on in HH:MM:SS |
| TOTAL CREDITS IN: | The total number of credits entered |
| TOTAL CREDIT CONTINUES: | The total number of credits used for continue games |
| TOTAL SERVICE CREDITS: | The total number of service credits entered |
| TOTAL SERVICE CONTINUES: | The total number of service credits used for continue games |
| TOTAL PLAYS: | The total number of games played |
| TOTAL AVERAGE GAME TIME: | The average game time for all games |
| BOOKKEEPING LAST CLEARED: | The time the bookkeeping meters were last cleared |
| HIGH SCORES LAST CLEARED: | The time the High Score tables were last cleared |
| CLEAR HISCORES: | When selected, the user will be prompted to confirm. If the user confirms (with the TEST button), the High Score table is reset. If the user presses SERVICE, then no action is taken. |
| CLEAR BOOKKEEPING: | When selected (with the TEST button), the user will be prompted to confirm. If the user confirms, the bookkeeping meters are reset to zero. If the user presses SERVICE, then no action is taken. |
| NEXT PAGE: | Proceed to bookkeeping screen #2 |
| EXIT: | Exit to System Menu |

Move the cursor to NEXT PAGE and press the TEST button to proceed to bookkeeping screen #2.

Move the cursor to EXIT and press the TEST button to return to the Test Menu.

Bookkeeping – Screen 2

This page displays cumulative individual modes and total plays. This is from the last point in time that the Bookkeeping was cleared.

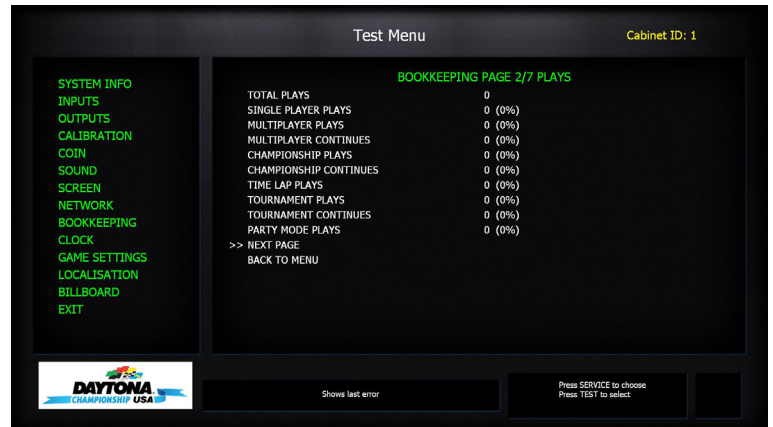

9-2 fig. 14

| | |
|-----------------------------|---|
| TOTAL PLAYS: | The total number of games played |
| SINGLE PLAYER PLAYS: | The total number of single player games |
| MULTIPLAYER PLAYS: | The total number of multiplayer games |
| CHAMPIONSHIP PLAYS: | The total number of Championship games |
| TOURNAMENT PLAYS: | The total number of Tournament games |
| PARTY MODE PLAYS*: | The total number of party mode games* |
| NEXT PAGE: | Proceed to bookkeeping screen #3 |
| BACK TO MENU: | Return to Test & Service Menu |

Move the cursor to NEXT PAGE and press the TEST button to proceed to bookkeeping screen #3.
Move the cursor to EXIT and press the TEST button to return to the Test Menu.

*Feature only available on DLX cabinets

Bookkeeping – Screen 3

This page displays total game time and average game times for single and multiplayer modes. This is a cumulative total from the last point in time that Bookkeeping was cleared. All times are displayed in the format **HHHH:MM:SS**

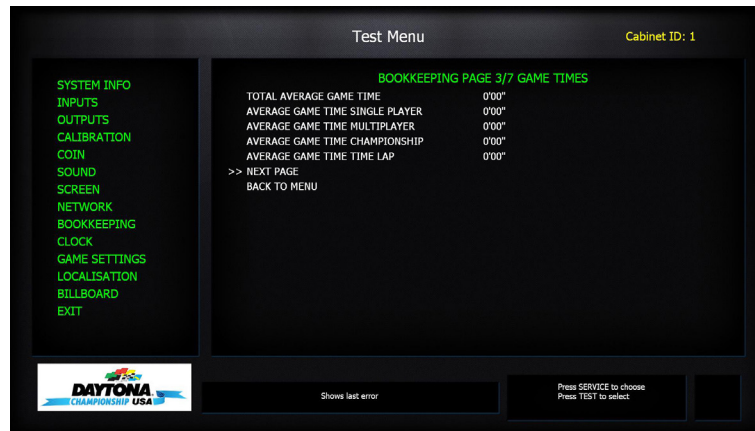

9-2 fig. 15

| | |
|--|---|
| TOTAL AVERAGE GAME TIME | Total average game time, all modes combined |
| AVERAGE GAME TIME SINGLE PLAYER | Average game time for all single player modes |
| AVERAGE GAME TIME MULTIPLAYER | Average game time for all multiplayer modes |
| AVERAGE GAME TIME CHAMPIONSHIP | Average game time for Championship mode |
| AVERAGE GAME TIME TIME LAP | Average game time for Time Lap |
| NEXT PAGE | Proceed to bookkeeping screen #4 |
| BACK TO MENU | Return to Test & Service Menu |

Move the cursor to NEXT PAGE and press the TEST button to proceed to bookkeeping screen #4.
Move the cursor to EXIT and press the TEST button to return to the Test Menu.

Bookkeeping – Screen 4

This page displays a breakdown of the games on individual days. This is a cumulative total from the last point in time that the bookkeeping was cleared.

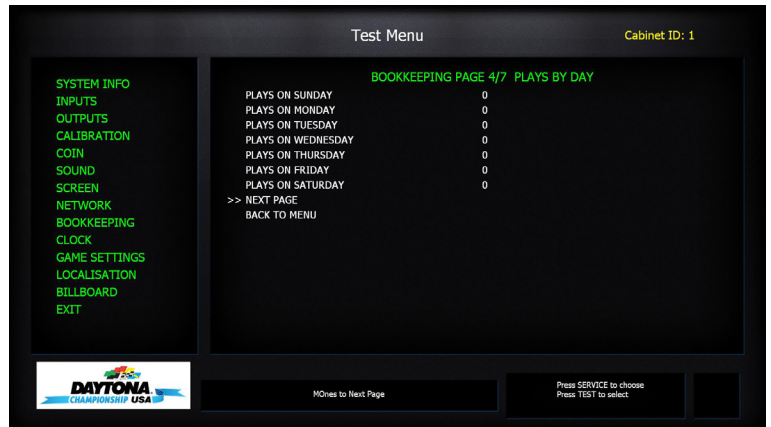

9-2 fig. 16

| | |
|----------------------------|--|
| PLAYS ON SUNDAY: | Cumulative count of plays for this day |
| PLAYS ON MONDAY: | Cumulative count of plays for this day |
| PLAYS ON TUESDAY: | Cumulative count of plays for this day |
| PLAYS ON WEDNESDAY: | Cumulative count of plays for this day |
| PLAYS ON THURSDAY: | Cumulative count of plays for this day |
| PLAYS ON FRIDAY: | Cumulative count of plays for this day |
| PLAYS ON SATURDAY: | Cumulative count of plays for this day |
| NEXT PAGE: | Proceed to bookkeeping screen #5 |
| BACK TO MENU: | Return to Test & Service Menu |

Move the cursor to NEXT PAGE and press the TEST button to proceed to bookkeeping screen #5.
 Move the cursor to EXIT and press the TEST button to return to the Test Menu.

Bookkeeping – Screen 5

This page displays a breakdown of the games into individual hours. This is a cumulative total from the last point in time that the bookkeeping was cleared.

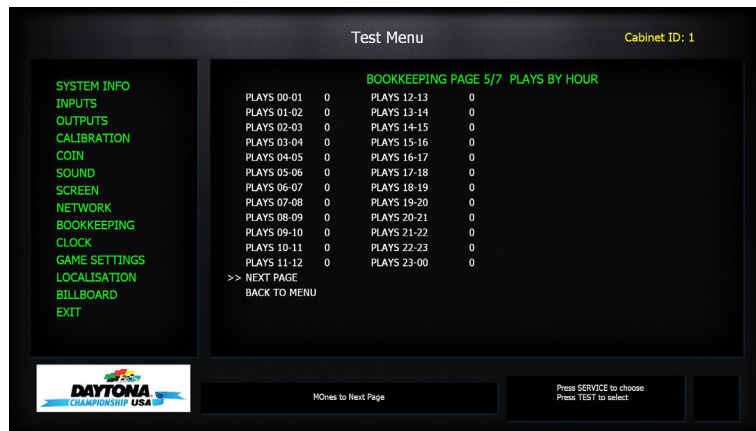

9-2 fig. 17

- PLAYS XX-XX:** Cumulative count of plays during the specified hour
- NEXT PAGE:** Proceed to bookkeeping screen #6
- BACK TO MENU:** Return to Test & Service Menu

Each hour is logged separately in 24 hour format therefore:

logs games played between 12am and 1am

logs games played between 1am and 2am and so on. 23-24 logs games played between 11pm and 12am.

Move the cursor to NEXT PAGE and press the TEST button to proceed to bookkeeping screen #6.

Move the cursor to EXIT and press the TEST button to return to the Test Menu.

Bookkeeping – Screen 6

This page displays a breakdown of the races into individual tracks. This is a cumulative total from the last point in time that the bookkeeping was cleared.

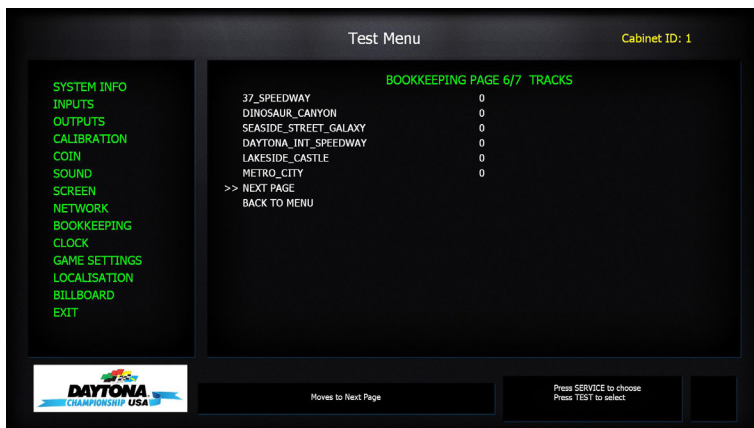

9-2 fig. 18

- TRACK #1 -6:** Cumulative count of plays on the specified track
- NEXT PAGE:** Proceed to bookkeeping screen #7
- BACK TO MENU:** Return to Test & Service Menu

Move the cursor to NEXT PAGE and press the TEST button to proceed to bookkeeping screen #7.
 Move the cursor to EXIT and press the TEST button to return to the Test Menu.

Bookkeeping – Screen 7

This page displays a breakdown of the different cars used in all game modes. This is a cumulative total from the last point in time that the bookkeeping was cleared.

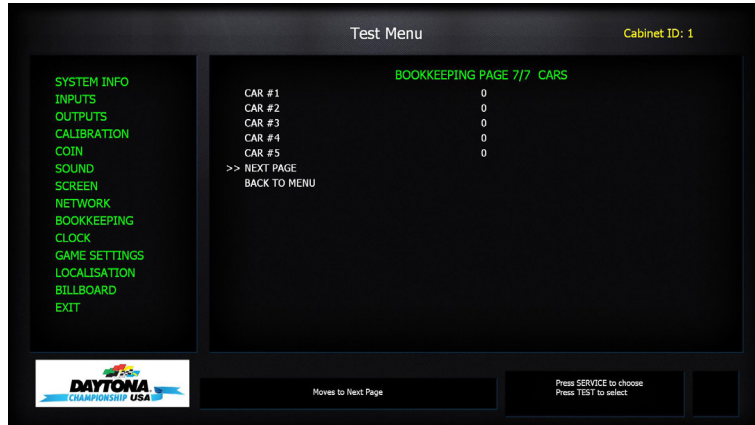





0-2 fig. 19

CAR #1 -5: Cumulative count of plays using the specified car
NEXT PAGE: Proceed to bookkeeping screen #1
BACK TO MENU: Return to Test & Service Menu

Use the SERVICE button to navigate and the TEST button to action changes to the following options. Move the cursor to BACK TO MENU and press the TEST button to return to the Test Menu.

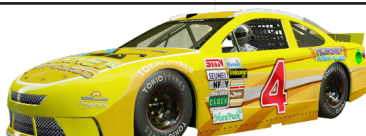
CAR REFERENCE TABLE

| | |
|--------------|--|
| CAR 1 |  9-2 fig. 20 |
| CAR 2 |  9-2 fig. 21 |
| CAR 3 |  9-2 fig. 22 |
| CAR 4 |  9-2 fig. 23 |
| CAR 5 |  9-2 fig 24 |

Clock Setting

This test is used to set the current time and date of the computer system. Select 'CLOCK' from the Test Menu to enter the Clock Setting screen. When selected, the screen will show fields for YEAR, MONTH, DATE, HOURS, MINUTES and SECONDS. The SERVICE button is used to select the desired option and the TEST button will increment the value of that option between specified parameters.

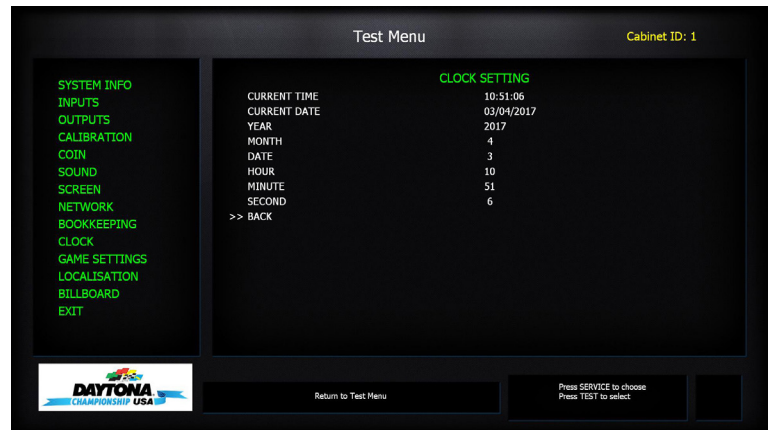

9-2 fig 25

| | |
|----------------------|--|
| CURRENT TIME: | Shows the current time, displayed in 24 hour clock format |
| CURRNT DATE: | Shows the Current Date, displayed in the following format DD/MM/YYYY |
| YEAR: | Variable from 2016 to 2070 |
| MONTH: | Variable from 01 to 12 |
| DATE: | Variable from 1 to 28, 29, 30 or 31 (dependant on MONTH & YEAR) |
| HOURS: | Variable from 0 to 23 |
| MINUTES: | Variable from 0 to 59 |
| SECONDS: | Variable from 0 to 59 |
| BACK: | Return to Test & Service Menu after adjusting clock to new value |

Use the SERVICE button to navigate and the TEST button to action changes to the following options. Move the cursor to BACK and press the TEST button to return to the Test Menu.

Game Settings 1

This allows game parameters to be viewed and changed. Select GAME SETTINGS from the Test Menu screen to enter the Game Settings screen.

If more than one cabinet is linked then game settings must be made from Cabinet 1 (Player 1) Test & Service Menu

CABINET 2-8 IN LINKED GAME

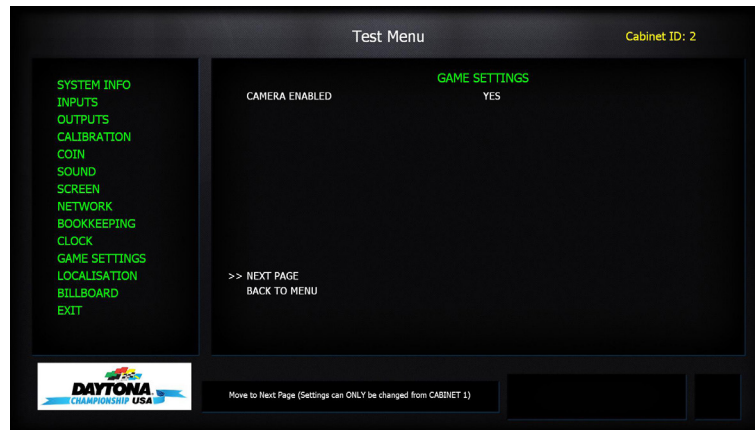

9-2 fig 26

Limited options can be changed when a linked cabinet that is not ID=1

| | |
|------------------------|---|
| CAMERA ENABLED: | Use the player camera in game (YES*/NO) |
| NEXT PAGE: | Proceed to Game Settings screen #1 |
| BACK TO MENU: | Return to Test & Service Menu |

WARNING

- When installing 2 of more cabinets which are networked together, the GAME SETTINGS which are adjusted within the first cabinet are reflected throughout all cabinets within that network.

Single Player/Cabinet 1 in Linked Game

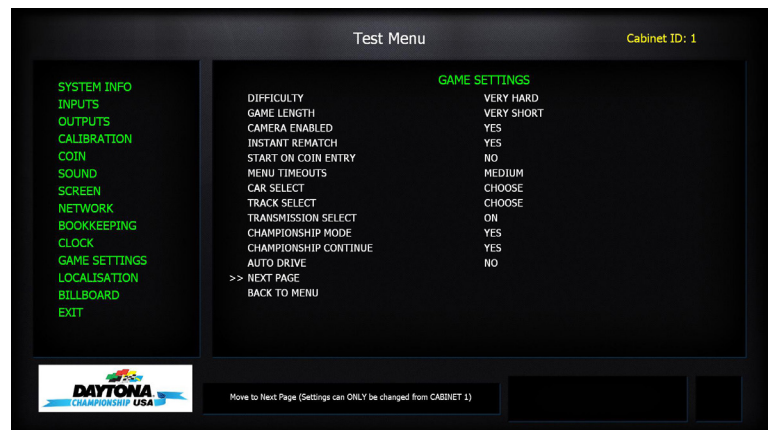

9-2 fig 27

| | |
|-------------------------------|---|
| DIFFICULTY: | Set the game difficulty (V EASY/EASY*/MEDIUM/HARD/V HARD) |
| GAME LENGTH: | Set the game length (V SHORT/SHORT*/MEDIUM*/LONG/V LONG) |
| CAMERA ENABLED: | Use the player camera in game (YES*/NO) |
| INSTANT REMATCH: | Offer instant rematch after multiplayer game (ON*/OFF) |
| START ON COIN ENTRY: | Game starts as soon as credit is available (YES/NO*) |
| MENU TIMINGS: | Length of time given to make menu selections (SHORT/MEDIUM*/LONG) |
| CAR SELECT: | Is player offered a choice of Cars (CHOOSE*/RANDOM/FIXED) |
| TRACK SELECT : | Is player offered a choice of tracks (CHOOSE*/RANDOM/FIXED) |
| TRANSMISSION SELECT: | Is player offered a choice of transmission (ON*/AUTO ONLY/MANUAL ONLY) |
| CHAMPIONSHIP MODE: | Is Championship Mode Enabled (YES*/NO) |
| CHAMPIONSHIP CONTINUE: | Is Championship Continue offered (YES*/NO) |
| AUTO DRIVE: | Is Auto drive feature enabled (YES/NO*) This will accelerate automatically if the player does not use the pedal |
| NEXT PAGE: | Proceed to Game Settings (Advanced) |
| BACK TO MENU: | Return to Test & Service Menu |

* Denotes default values

Use the SERVICE button to navigate and the TEST button to action changes to the following options. Move the cursor to BACK and press the TEST button to return to the Test Menu. Alternatively highlight NEXT PAGE and push the TEST button to go to the advanced game settings page.

Game Settings (Advanced)

This page allows for advanced game parameters to be viewed and changed. Select GAME SETTINGS from the Test Menu screen to enter the Game Settings screen. From there highlight NEXT PAGE and push the TEST button to reach the GAME SETTINGS (ADVANCED) screen.

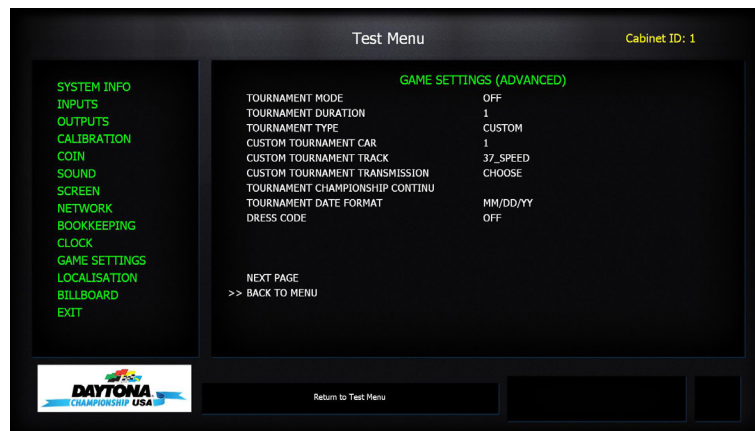

9-2 fig 28

| | |
|---------------------------------|---|
| TOURNAMENT MODE: | Enables or Disables Tournament Mode (YES/NO*) |
| TOURNAMENT DURATION: | Sets the duration of tournament in days (*1-30 days) |
| TOURNAMENT TYPE: | Define tournament type (CHAMPIONSHIP/CUSTOM*) |
| CUSTOM TOURNAMENT CAR: | Defines Car for tournament if custom is enabled (1,2,3,4,5, *Choice) |
| CUSTOM TOURNAMENT TRACK: | Defines Track for tournament if custom is enabled (1,2,3,4,5,6, *Choice) |
| CUSTOM TOURNAMENT TRANS: | Defines Transmission for tournament if custom is enabled (MANUAL/AUTO/ *Choice) |
| TOURNAMENT CSHIP CONT: | When Tournament is set to CHAMPIONSHIP, is continue option available (YES*/NO) |
| TOURNAMENT DATE FORMAT: | Defines how Tournament duration date is displayed (MM/DD/YY*, DD/MM/YY, YY/MM/DD) |
| NEXT PAGE: | Proceed to Game Settings screen #1 |
| BACK TO MENU: | Return to Test & Service Menu |

Tournament Set Up

Tournament allows an operator to set up a time limited single player event. This can be customised and records are stored in a unique “Tournament” high score table. Once the time has elapsed the high score table will still be displayed but no further record can be set.

To set up a tournament, please make the desired adjustments in the Game Settings (advanced) screen as described on the previous page.

Before attempting to change the duration of days for tournament mode, please follow these instructions:

- Turn Tournament mode off via “Game Settings” in the Test Menu
- Start the game up (load to attract screen)
- Return to the Test Menu
- Turn Tournament mode back on
- Change duration to whichever amount of days you wish to test

Failure to follow steps will cause the cabinet to not give the option of tournament mode in the menu.

Use the SERVICE button to navigate and the TEST button to action changes to the following options. Move the cursor to BACK and press the TEST button to return to the Test Menu.

Localisation

This allows the game language to be selected. On linked cabinets this can only be carried out from Cabinet ID 1. (Player 1).

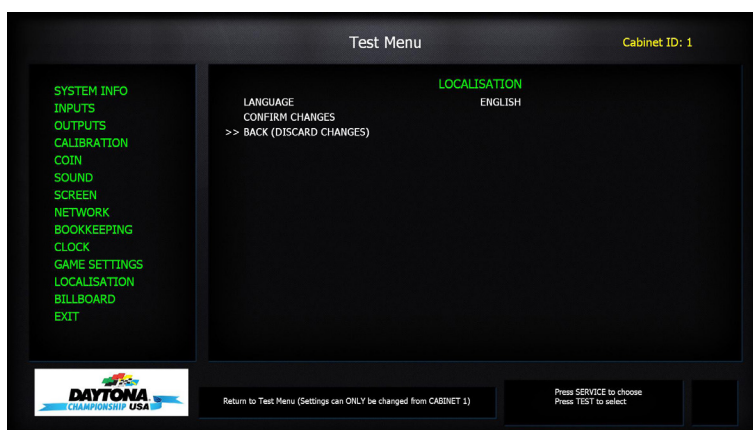

9-2 fig 29

LANGUAGE:

Select the game language:

ENGLISH/FRENCH/ITALIAN/SPANISH/PORTUGUEUSE/RUSSIAN/
TURKISH

CONFIRM CHANGES:

The user will be prompted to press TEST again to confirm. If the user presses TEST again, the action is confirmed and the Cab will reset. If performed on Cabinet 1 of a group of linked cabinets, all will be changed and restarted

If SERVICE is pressed the action is aborted and settings discarded.

BACK TO MENU:

Return to Test & Service Menu

10 VIDEO DISPLAY

CAUTION

The LCD display screen is adjusted prior to leaving the factory. Avoid any unnecessary adjustment.

IMPORTANT

- If the adjustment method in this manual does not resolve the problem, contact the customer service number in this manual or your supplier.
- Do not stick tape, stickers, or anything else onto the screen. Any kind of adhesive may damage the surface of the screen.

10-1 GENERAL DESCRIPTION

This specification applies to the 46.0 inch Color TFT-LCD Module P460HVN02.0. This LCD module has a TFT active matrix type liquid crystal panel 1920x1080 pixels, and diagonal size of 46.0 inch. This module supports 1920x1080 resolution display. Each pixel is divided into Red, Green and Blue sub-pixels or dots which are arranged in vertical stripes. Gray scale or the brightness of the sub-pixel color is determined with a 10-bit gray scale signal for each dot.

The P460HVN02.0 has been designed to apply the 10-bit 2 channel LVDS interface method. The main feature of P460HVN02.0 would be high brightness, high contrast, wide viewing angle, high color saturation, symmetry narrow bezel, edge LED backlight and high color depth.

* General Information

| Items | Specification | Unit | Note |
|------------------------|---------------------------------|------------|------|
| Active Screen Size | 46.0 | Inch | |
| Display Area | 1018.08(H) x 572.67(V) | mm | |
| Outline Dimension | 1044.08(H) x 598.67(V) x 9.9(D) | mm | 1 |
| Driver Element | a-Si TFT active matrix | | |
| Display Colors | 10 bit (8bit+FRC), 1073.7M | Colors | |
| Number of Pixels | 1920x1080 | Pixel | |
| Pixel Pitch | 0.53025 (H) x 0.53025(W) | mm | |
| Pixel Arrangement | RGB vertical stripe | | |
| Display Operation Mode | Normally Black | | |
| Display Orientation | Landscape/Portrait Enable | | |
| Surface Treatment | AG | Haze = 11% | |

Note:

(1) Dmax: 26.5mm (Front bezel to Driver cover); Dmin: 9.9mm (Front bezel to Bezel back)

10-2 CLEANING THE SCREEN

⚠ CAUTION

- Since the LCD display screen is susceptible to damage, pay careful attention to its handling. When cleaning, refrain from using water or volatile chemicals.
- Do not climb onto the control panel as this could lead to injuries.
- When reaching across the control panel to clean the screen, there is a risk of hurting your shoulder or arm. Use a mop with a non-feathery, soft, dry cloth mop head and wipe the surface of the screen.

When the screen surface becomes dirty with dust, etc., clean it by using a soft cloth such as gauze. When water, and volatile chemicals such as benzene, thinner, etc., spill on the screen surface, it may be subject to damage, therefore, do not use them.

Also, since the surfaces are susceptible to damage, refrain from rubbing them with a hard material or using a duster. If the screen is especially dirty, call in a professional cleaner.

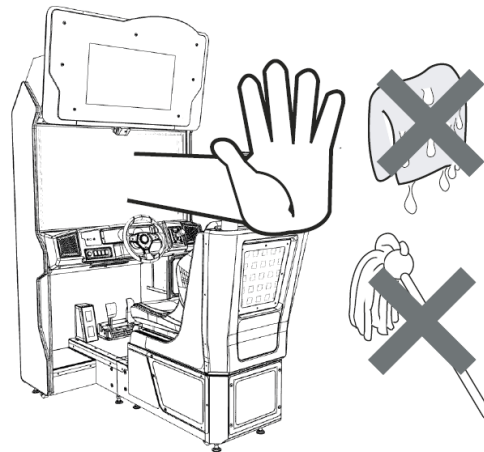

10-2 fig. 01

10-3 ADJUSTMENT METHOD

All adjustment values are set accurately at the time of shipping from the factory. Do not adjust these values needlessly or apply adjustments not specified in this manual. The display may not appear properly if the values are incorrect.

CONTROL - ADJUSTMENT PROCEDURE

This sections explains basic control procedures for making adjustments using the buttons on the 'Monitor Adjustment Board'

LOCATION

The DISPLAY CONTROL BD is located on the rear of the Display Panel. Remove the Back Door to gain access.

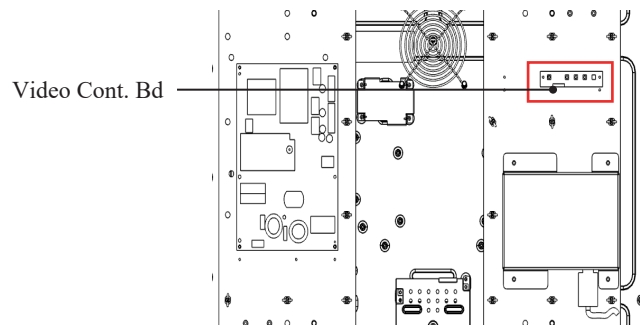
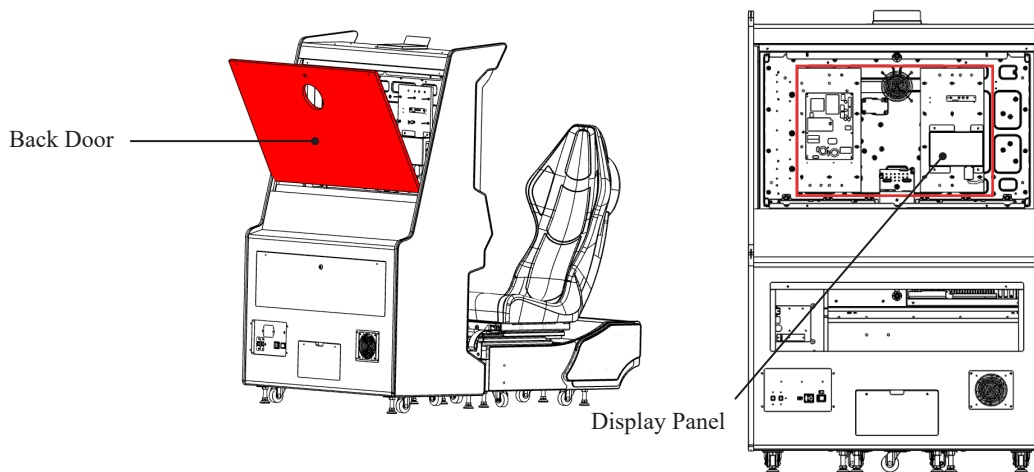

Button Names and Functions

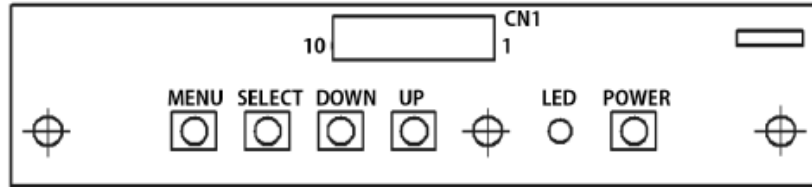

10-3 Fig. 04

- MENU:** Turn the Picture Menu display ON and OFF.
- SELECT:** Gains entry to the Item selected in the menu. (Highlights in Yellow when selected)
Exits the Item adjustment. Any changes made during this operation are actioned.
- DOWN:** Moves the cursor (Black Bar) down to select a menu item.
Decrease the value of, or change, a selected menu item.
- UP:** Move the cursor (Black Bar) up to select a menu item.
Increase the value of, or change, a selected menu item.
- LED:** LED illuminates green: Monitor is operating.
LED flashes red: Power is off.
- POWER:** Turns the LCD Display ON and OFF (usually, this is not necessary to operate)

On-Screen Display (OSD)

Press the MENU Button while the OSD is not displayed to bring up the Picture Menu.
On the Picture Menu, it is possible to perform various screen adjustments.



10-3 Fig. 05

Use the UP and DOWN Buttons to move the 'Black Bar' to the item you want to adjust.
After selecting the desired item, pressing the SELECT Button will extend the MENU Screen and allow adjustments to be changed.

Within each item, press the SELECT Button to exit the adjustment screen. The adjustment values at this time will be saved simultaneously.

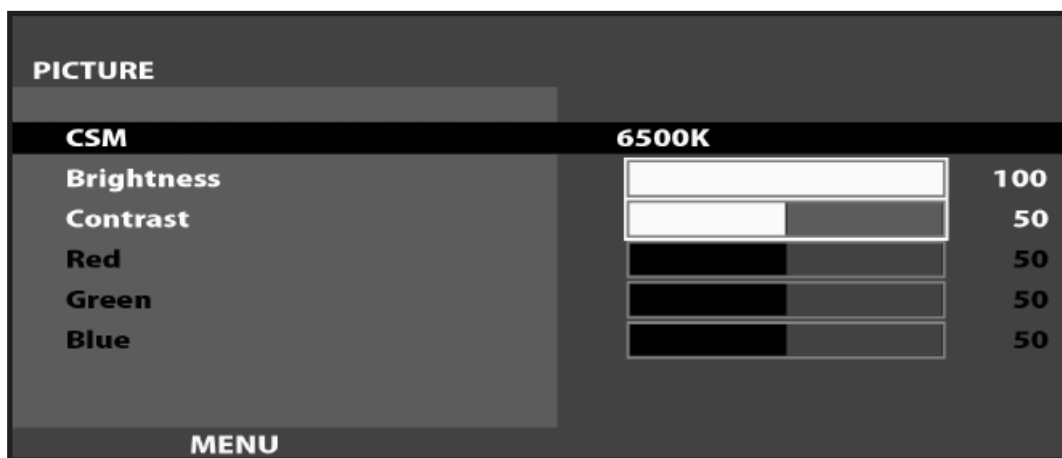

10-3 Fig. 06

The current options are set at :

| | | |
|------------|---|-------|
| CSM | - | 6500K |
| Brightness | - | 100 |
| Contrast | - | 50 |

On-Screen Display (OSD) <continued>

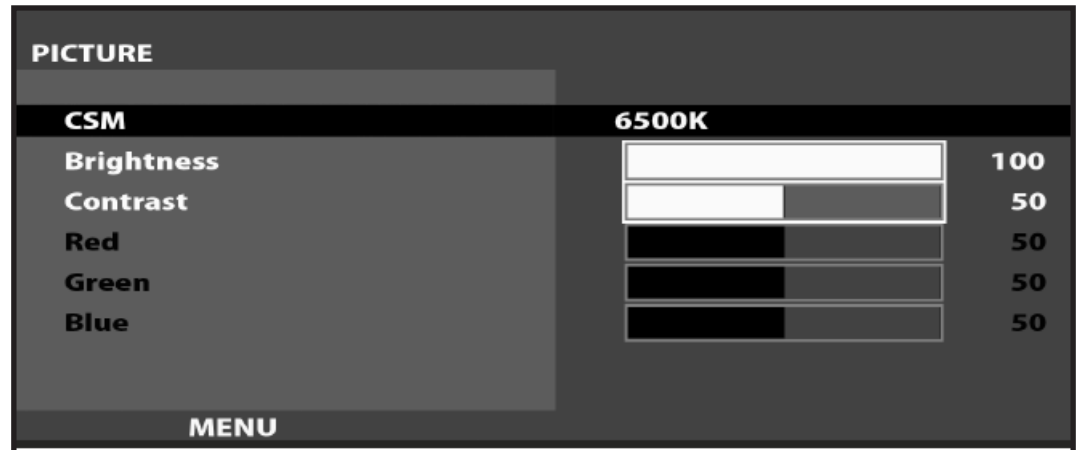

10-3 Fig. 07

Available Settings

CSM (Selects Operation Mode)
Selection available - 6500K - 9300K - USER

BRIGHTNESS (Adjust Brightness)
Adjust screen Brightness. - Values: 0 - 100
(0" being the darkest setting, and "100" being the brightest)

CONTRAST (Adjust Contrast)
Adjust Contrast level. - Values: 0 - 100
(0" having the least amount of difference between light and dark, and "100" having the most)

NOTE : The Red, Green, and Blue adjustments are unavailable in the Mode of Operation selected on the Screen shown in 11-3 Fig. 06. These adjustments can only be made if the CSM option is set to 'User'.

11 CONTROL UNITS

WARNING

- When working with the product, be sure to turn the power off. Working with the power on may cause an electric shock or short circuit.
- Be careful not to damage the wires. Damaged wires may cause an electric shock, short circuit or present a risk of fire.
- Do not touch any parts that are not specified in these directions. Touching unspecified locations may lead to electric shock or cause short circuits.
- This work should be performed by site maintenance personnel or other skilled professionals. Work performed by non-technical personnel can cause a severe accident such as an electric shock.
- Exercise due caution in performing soldering procedures. If soldering iron is handled carelessly, there could be fires or burns.
- Proceed very carefully when heating thermal contraction tube. Careless operations can result in fires or burns.

CAUTION

- When fastening plastic parts, be careful not to tighten screws and nuts excessively or parts may be damaged, resulting in injuries from fragments, etc.
- Be careful not to get hand or finger caught when removing or attaching the parts.
- Disconnection and connection of connectors will be performed within the narrow cabinet space. Take due care not to scratch or otherwise injure yourself.
- Take care when carrying the removed Control Units. Such heavy lifting carries a risk of injury to back or shoulders.

IMPORTANT

- After the Potentiometer has been replaced, be sure to set the values on the test mode CALIBRATION and INPUT test screen, and check variations in the volume value.
- Handle parts inside the Control Unit very carefully. Be especially careful to avoid damage, deformation, or loss of these parts. If any one of these parts is lost or defective, it can result in damages and/or faulty operations.

 **CAUTION**

- After the unit has been disassembled and reassembled again, check carefully that the unit has been reassembled correctly.
- Be sure to inspect the outer covers on both gear and brake units.
- Assemble so that there is no gap between the L and R covers. If there is a gap or rattling, the players could get fingers or hands caught, resulting in injury.

 **IMPORTANT**

- Once the product has been disassembled, use slack preventive agent. Coat screws with suitable amounts of this agent and then tighten them. If this agent is not used, the product might start rattling or come apart.
- Use the slack preventive agent prescribed in these instructions. If any other agent is used, there could be chemical changes that inhibit the use of screws and part surfaces could be damaged.
- Be careful not to damage or lose small parts or screws.
- When a part has been replaced, be sure to always make adjustments and check conditions in Test Mode.

11-1 CONTROLLER - EXPLODED DIAGRAM

The exploded diagram below shows the Active Steering Wheel Assy. Each part is tagged with a part number. Please quote this number when ordering spare parts.

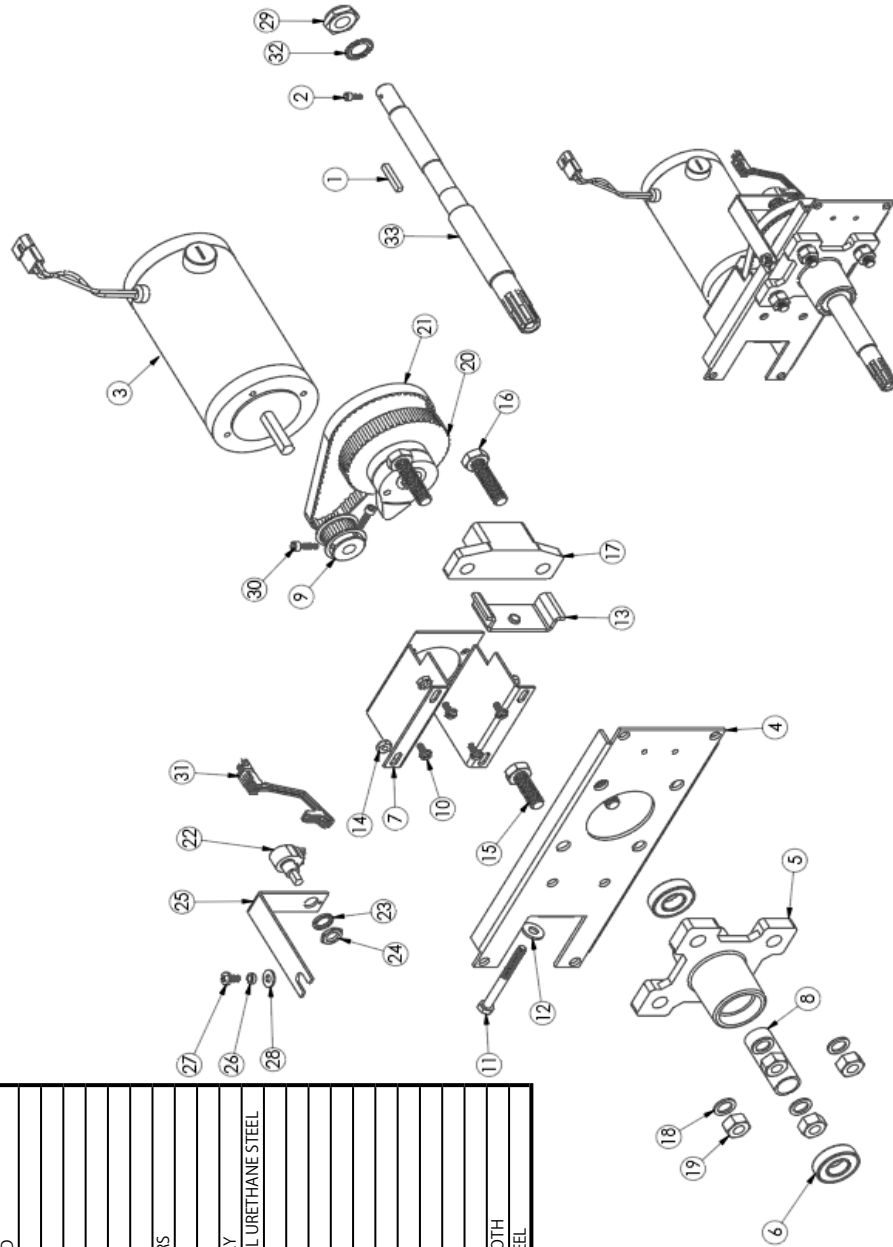

| ITEM No | QTY | PART No | DESCRIPTION |
|---------|-----|---------|---|
| 1 | 1 | DA-0101 | KEY SHAFT 4MM X 4MM X 25MM |
| 2 | 1 | DA-0102 | SCREW #6-32 X 3/8" SHCS |
| 3 | 1 | DA-0103 | MOTOR & CONNECTOR ASSY |
| 4 | 1 | DA-0104 | WHEEL MTG BKT |
| 5 | 1 | DA-0105 | BEARING HOUSING |
| 6 | 2 | DA-0106 | BEARING .9843ID X 1.2590OD X 1.575W |
| 7 | 1 | DA-0107 | MOTOR MTG BKT |
| 8 | 1 | DA-0108 | BEARING SPACER |
| 9 | 1 | DA-0109 | PULLEY 16T ALUMINIUM |
| 10 | 4 | DA-0110 | SCREW #8-32 X 3/8" HEX WSHR HD |
| 11 | 1 | DA-0111 | SCREW M6 X 60MM HHCS |
| 12 | 1 | DA-0112 | 5/16 FLAT WSHR .06T ZINC PLT |
| 13 | 1 | DA-0113 | BKT BELT TENSION |
| 14 | 4 | DA-0114 | NUT 10-32 HEX SEAMS ZINC PLT |
| 15 | 2 | DA-0115 | SCREW M10 X 30MM HHCS |
| 16 | 2 | DA-0116 | SCREW M10 X 40MM HHCS |
| 17 | 1 | DA-0117 | DIE CAST WHEEL STOP W/BUMPERS |
| 18 | 4 | DA-0118 | LOCKWASHER M10 RIBBED |
| 19 | 4 | DA-0119 | NUT HEX M10 |
| 20 | 1 | DA-0120 | STOPPER PIE CAM & PLASTIC PULLEY |
| 21 | 1 | DA-0121 | TIMING BELT FOR STEERING WHEEL URETHANE STEEL |
| 22 | 1 | DA-0122 | SK POT NEI SENSOR CUBE |
| 23 | 1 | DA-0123 | LOCKWASHER INT 3/8" X 9/16" |
| 24 | 1 | DA-0124 | NUT HEX 3/8" - 24 X 3/32 THK |
| 25 | 1 | DA-0125 | POT MTG BKT |
| 26 | 1 | DA-0126 | SPACER POT MTG BKT |
| 27 | 1 | DA-0127 | SCREW #10-32 X 3/8" PHPNHD |
| 28 | 1 | DA-0128 | #10 FLAT WASHER |
| 29 | 1 | DA-0129 | NUT HEX NYLOCK 1/2-20 |
| 30 | 2 | DA-0130 | SCREW #8-32 X 5/8" SHCS |
| 31 | 1 | DA-0131 | HARNES FOR NEI POT |
| 32 | 1 | DA-0132 | STAR WASHER M14 EXTERNAL TOOTH |
| 33 | 1 | DA-0133 | SEGA SHAFT 270 DEG ACTIVE WHEEL |

11-1 fig. 01

11-2 BRAKE AND ACCELERATOR UNIT

WARNING

When working with the product, be sure to turn the power off. Working with the power on may cause an electric shock or short circuit. However, the unit must be switched on when using test mode. Do not touch any part of the unit except the areas indicated.

Be careful not to damage wires. Damaged wires may cause an electric shock, short circuit or present a risk of fire.

This work should be performed by site maintenance personnel or other skilled professionals. Work performed by non-technical personnel can cause a severe accident such as an electric shock.

To prevent accidents while working or while operating the product after it has been installed, be sure not to conduct any procedures other than those given in this manual. There are cases in which procedures not covered in this manual require special tools and skills.

If a procedure not given in this manual is required, request service from the office given in this manual or from the point of purchase.

IMPORTANT

Be sure to perform volume's move value setting in the Input Test in the Game Test Mode after replacing or adjusting the Volume.

If the accelerator or brake pedals are not functioning correctly, you may need to adjust the positioning of the volume or replace it with a new one. In addition, you should apply grease to the gear contacts and spring parts once every three months.

When the accelerator pedal is not being pressed, the accelerator volume should have a value of 30H or less. When the pedal is being pressed, the value should be C0H or greater.

When the brake pedal is not being pressed, the value should be 35H or less. When the pedal is being pressed, it should be D0H or more. You can view these values in test mode. Note that the unit must be switched on to use test mode. Do not touch any part of the unit except those areas indicated when the unit is switched on, as there is a danger of electrical shock or short-circuit.

For this task, you will need a Phillips-head screwdriver (for M4, M5 screws).

Adjusting Procedure

- 1 On the accelerator and brake pedal unit, remove the two truss screws and lift off the front cover.

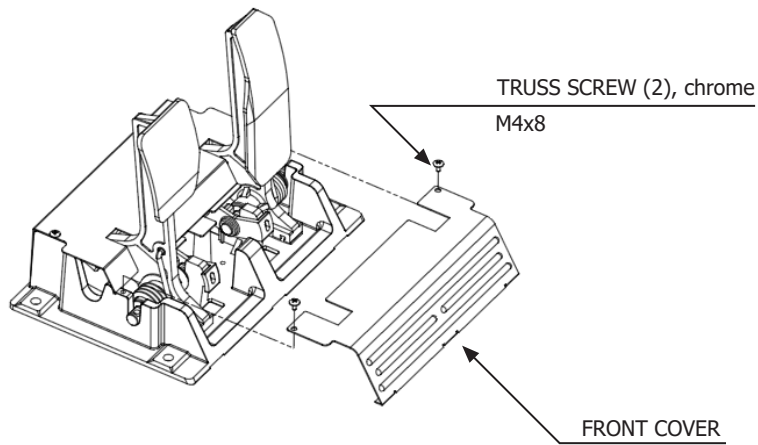

11-2 fig. 01

- 2 Loosen the single screw that secures the potentiobase, and move the base to adjust the volume values.

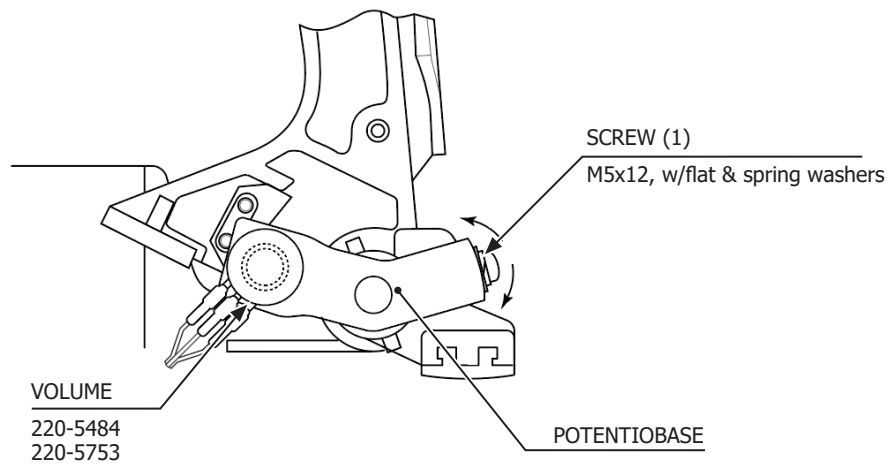

11-2 fig. 02

- 3 Secure the potentiobase.
- 4 Configure the volume values on the INPUT ASSIGNMENTS screen in Game Test Mode.
- 5 Check that the values change smoothly in response to pedal input.

11-3 ADJUSTING/REPLACING THE VOLUME POT

Replacing the Volume

- 1 Remove power from the cabinet.
- 2 Remove the two screws and lift off the potentiometer cover.

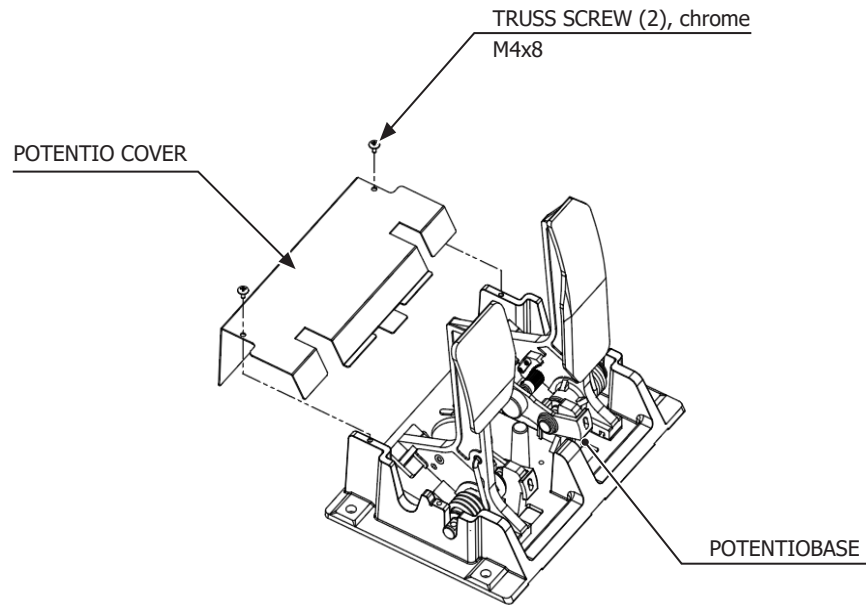

11-3 fig. 01

- 3 Detach the connector from the volume to be replaced.
- 4 Remove the single screw that secures the potentiometer base. (see 11-3 FIG. 01).
- 5 Without detaching the volume, remove the potentiometer base. (see 11-3 FIG 02).
- 6 The wire connected to the volume pot will be reused. Use a tool such as a pair of snips or cutters to remove the old heatshrink tubes which cover the contacts.

- 7** Use a soldering iron to melt the solder and separate the wires from the old volume pot. Be very careful when using a soldering iron.

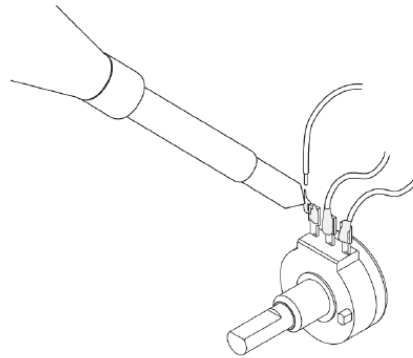

11-3 fig. 02

- 8** If the exposed conductive wire at the end is less than 5mm, use a tool such as a wire stripper or cutter to cut the wire insulation back to a workable length. Place new sleeving over the wire before resoldering them to the pot.
- 9** Once soldered, cover the bare contacts with the sleeving. If heatshrink is used, apply heat from an appropriate hot air blower to shrink the sleeving tightly over the contacts.
- 10** Reassemble the pot to the pot bracket by working in reverse order of these instructions. Refer to the POT VOLUME ADJUSTMENT section of this manual.

11-4 GREASING

STOP IMPORTANT

Use only the specified grease. Using any other kind of grease can result in damage to parts.

Once every three months, you should apply grease to the gear contacts and spring parts. Use Grease Mate-brand spray grease (Part No.: 090-0066).

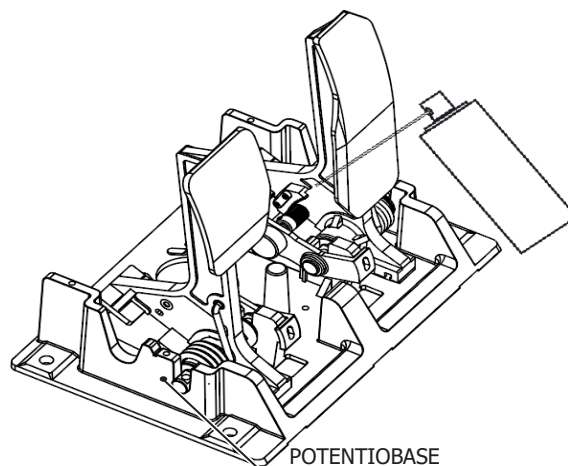

11-4 fig. 01

11-5 SHIFT LEVER

WARNING

- When working with the product, be sure to turn the power off. Working with the power on may cause an electric shock or short circuit.
- Be careful not to damage the wires. Damaged wires may cause an electric shock, short circuit or present a risk of fire.

If the shift lever switch input does not function correctly on the INPUT TEST screen, the switch may need to be replaced. To carry out this maintenance, you must first remove the shift lever unit. For this task, you will need a tamper proof wrench (for M5 screws), /and a Phillips-head screwdriver (for M4 screws).

11-6 REMOVING THE SHIFT LEVER

- 1 Turn the power OFF
- 2 Using the M5 tamper proof wrench remove the four tamper proof screws, 1 located in each of the corner of the Shift Lever.
- 3 Gently lift out the Shift Lever to reveal the wiring harness, locate the plug connecting it to the Control panel and remove the connection. The Shift Lever can now be extracted.
- 4 When re-installing the Shift Lever follow the above instructions in the reverse order.
- 5 After the re-installation of the Shift Lever, be sure to check the INPUT TEST in the Game Test mode to determine it's correct operation.

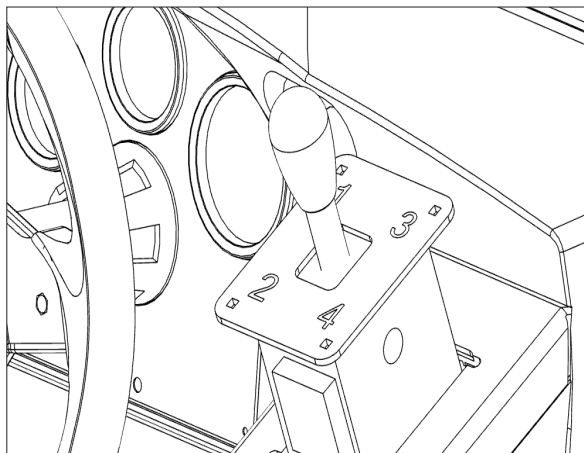

11-6 fig. 01

11-7 SHIFT SWITCH REPLACEMENT

Follow the instructions below to change the microswitch.

- 1** Unscrew and remove the M3x16 Self Tapping Screws which secure the microswitch to the Gear Shift base.
- 2** Remove the microswitch
- 3** Remove the wiring harness from the old microswitch and re-attach it to the replacement switch in the same manner

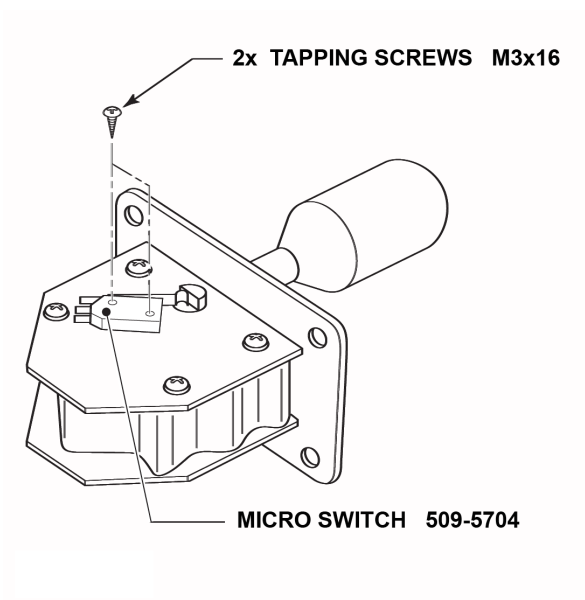

11-7 fig. 01

- 4** Using the M3x16 Self Tapping Screws, refit the replacement microswitch to the Gear Shift base.
- 5** The unit is now ready to be refitted into the Control Panel. To do this, follow the instructions in reverse order

12 COIN HANDLING

Handling the Coin Jam

If the coin is not rejected when the REJECT button is pressed, open the coin chute door and open the selector gate. After removing the jammed coin, put a normal coin in and check to see that the selector correctly functions.

12

COIN HANDLING

12-1 CLEANING THE COIN SELECTOR

STOP IMPORTANT

- Remove and clean smears by using a soft cloth dipped in water or diluted chemical detergent and then squeezed dry.
- Never apply machine oil, etc. to the Coin Selector.
- After cleaning the Coin Selector, insert a regular coin in the normal working status and ensure that the selector correctly functions.

The Coin Selector should be cleaned once every 3 months.
When cleaning, follow the procedure below:

- 1 Turn the power for the machine OFF. Open the Coin Chute Door
- 2 Remove the Coin Selector from the Coin Chute Door
- 3 Open the gate and dust off by using a soft brush (small soft Paint Brush, etc.)

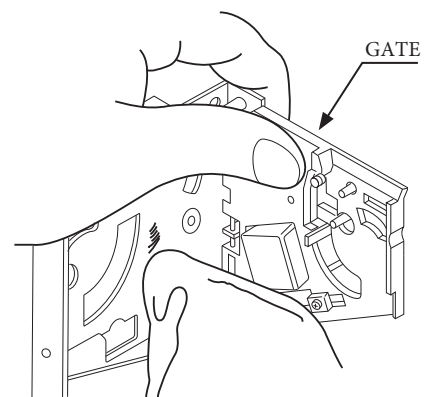

12-1 FIG 1

CLEANING THE COIN SELECTOR (MECHANICAL).

1 Remove and clean smears by using a soft cloth dipped in water or diluted chemical detergent and then squeezed dry.

2 Remove the CRADLE. When removing the retaining ring (E ring) be very careful so as not to bend the rotary shaft.

3 Remove stain from the rotary shaft and shaft receiving portions by wiping off with a soft cloth, etc.

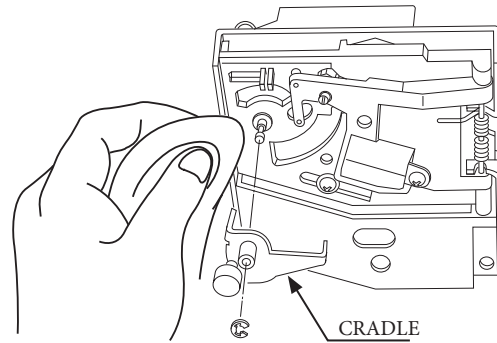

12-1 FIG 2

4 After wiping off as per previous step, further apply a dry cloth to completely dry the Coin Selector.

Coin Insertion Test

Once every month, when performing the Coin SW Test, simultaneously check the following:

Does the Coin Meter count satisfactorily?

Does the coin drop into the cashbox correctly?

Is the coin rejected when inserted while keeping the REJECT Button pressed down?

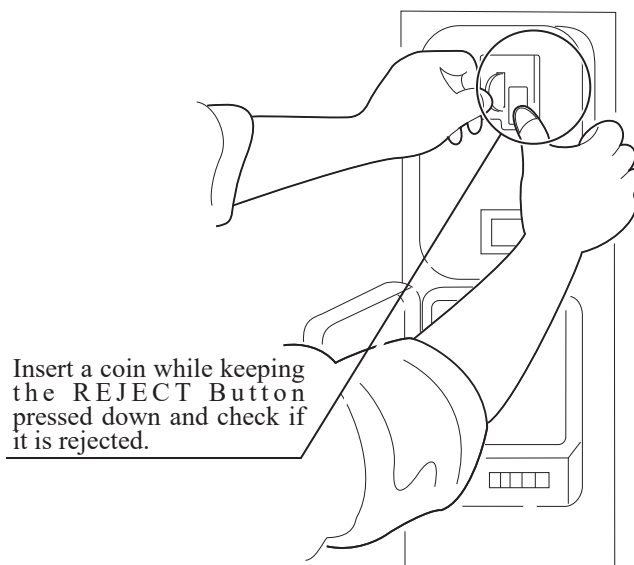

12-1 FIG 3

CLEANING THE COIN SELECTOR (SR3 / NRI)

12

COIN HANDLING

- 1 Remove and clean smears by using a damp soft cloth dipped in water. DO NOT use any diluted chemical detergent or cleansing agent as this will impair the workings of the component.

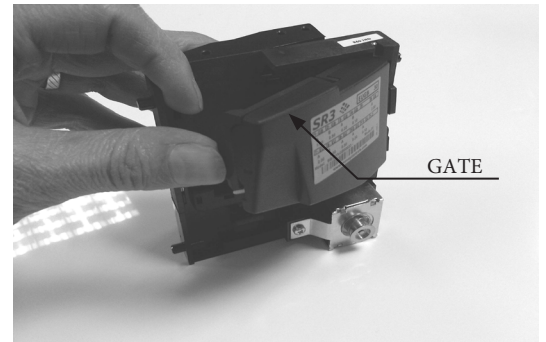

- 2 Open the reject gate to gain access to the rundown path.

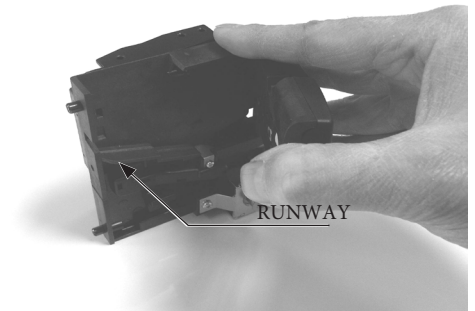

- 3 Remove the dirt and stains from the runway by wiping off with a soft damp cloth.



- 4 After wiping off as per previous step, further apply a dry cloth to completely dry the coin Selector.

12-2 FAULT FINDING

Fault Finding

The following information is presented for customers' guidance in rectifying a fault but does not cover all possible causes.

All acceptors with electronic faults should be returned to an approved service centre for repair.

| SYMPTOM | INVESTIGATE | POSSIBLE CAUSE |
|--|-----------------------|--|
| Acceptor does not work (all coins reject) | Connector | Poor Contact |
| | | Loose Wire |
| | Power Supply | Not switched on |
| | | Incorrect voltage |
| | | Inadequate current |
| | | Rise time too slow |
| | Inhibit all inputs | Acceptor Inhibited |
| | Accept gate | Gate not free or dislocated |
| | Accept channel | Obstruction |
| | Reject gate | Not fully closed |
| | LED on rear cover RED | EEPROM chksm error |
| | | SR Sensor fault |
| | | Credit opto fault |
| Credit sensor blocked | | |
| | Reject lever pressed | |
| LED on rear cover YELLOW | Reinstall power | |
| Poor Acceptance | Power Supply | Voltage less than 10v (Voltage drops when coil engages) |
| | Accept gate | Gate jam or dislocated |
| | Connector | Loose |
| | Coin rundown | Dirty |
| | Bank Select | Both banks enabled |
| Coin stick or jam in acceptor | Accept channel | Acceptor dirty or may have some damage |
| | Accept gate | |
| | Reject gate | |
| A true coin type rejects | Label | Coin not programmed |
| No accept signal | Connector | Loose or broken wire |
| | Accept channel | Path dirty or obstructed |

12-3 ADJUSTING THE PRICE OF PLAY (EXCEL)

STOP IMPORTANT

- The price of play is determined by the configuration of switches located on either the EXCEL or VTS board. The type of board used is determined by product location. Switch settings for both types of board remain the same.

This product comes equipped with a Crane NRI Coin Acceptor. To adjust the price of play ALL CREDIT SETTINGS are adjusted via the EXCEL CREDIT BOARD.

IMPORTANT!

The CREDIT SETTINGS within the SYSTEM TEST MODE must be set to 1 coin 1 credit to allow the CREDIT BOARD to function correctly.

The CREDIT BD has a built in accumulator. This is controlled by 2 DIL Switches. These allow the operator to select the price of play, type of coin acceptor and region.

EXCEL Credit Board

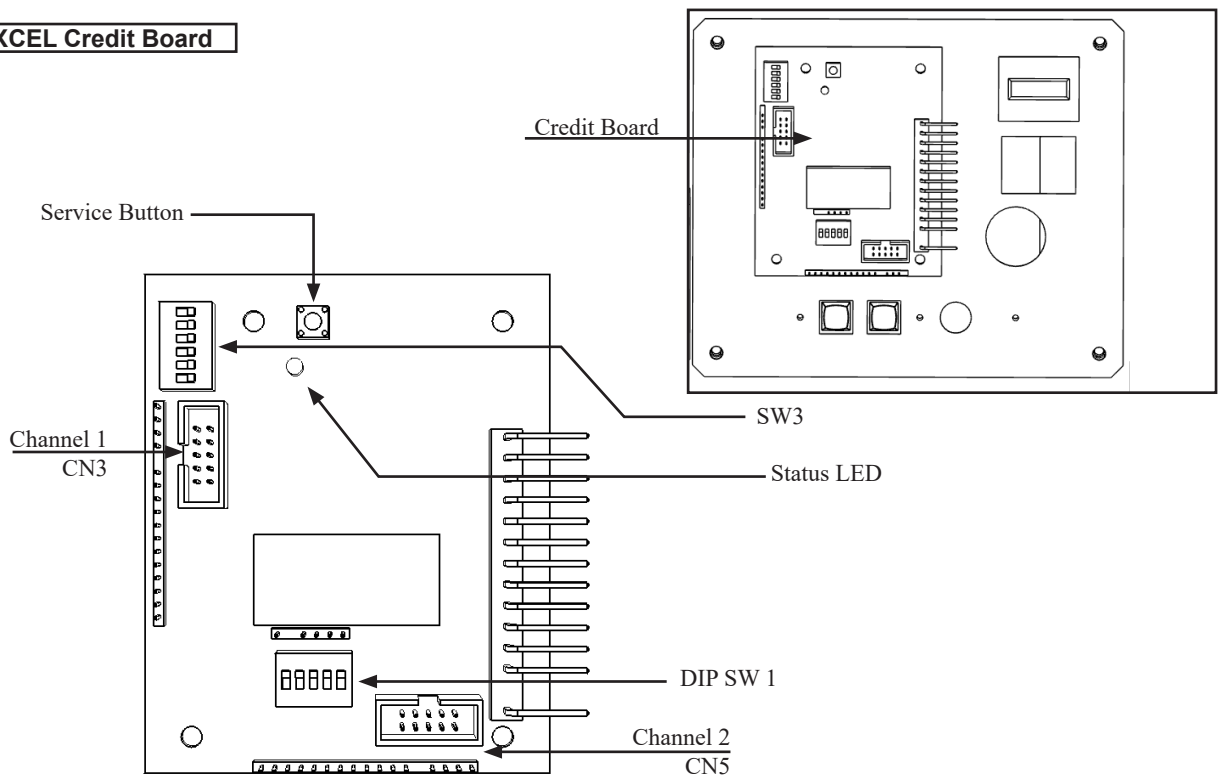

DIL SW3 (Regional Settings)

Adjust these switches to specify the type of Coin Acceptor used and currency.

Default = SW1&SW2 ON - SR3/NRI in parallel mode, Sterling.

SERVICE BUTTON

Status LED

CHANNEL 1

DIL SW1 (credit settings)

VOL CONTROL

Provides a SERVICE CREDIT when pressed

Flashes when functioning.

To Coin Acceptor (SR3 TYPE.)

Adjust to required price of pay.

MAIN VOLUME ADJUSTMENT (FRONT SPEAKERS)

12-4 ADJUSTING THE PRICE OF PLAY (VTS)

This product comes equipped with a Crane NRI Coin Acceptor. To adjust the price of play ALL CREDIT SETTINGS are adjusted via the VTS CREDIT BOARD.

IMPORTANT!

The CREDIT SETTINGS within the SYSTEM TEST MODE must be set to 1 coin 1 credit to allow the CREDIT BOARD to function correctly.

The VTS BD has a built in Credit Board. This is controlled by 2 DIL Switches. These allow the operator to select the price of play, type of coin acceptor and region.

VTS Board

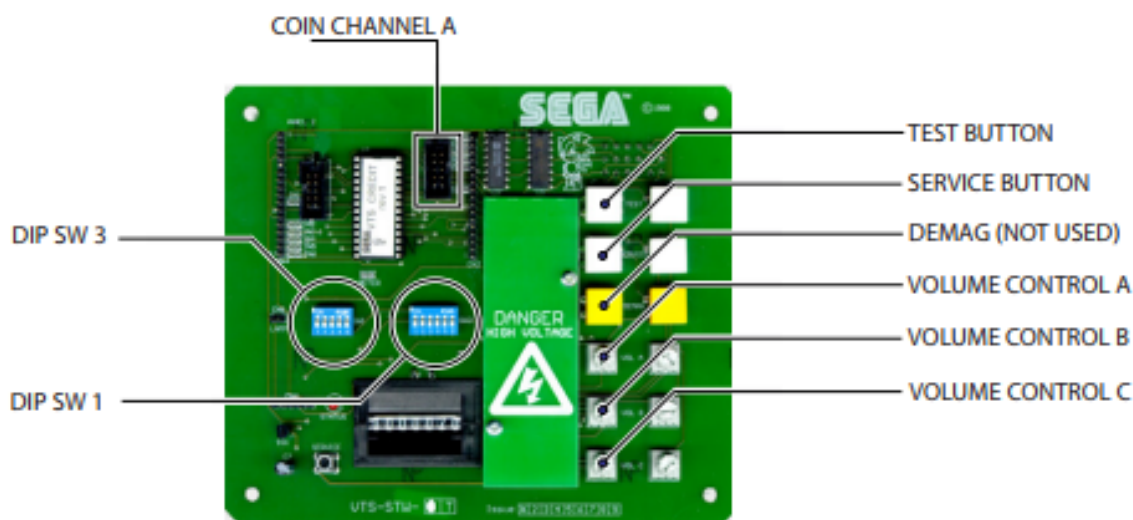

DIL SW3 (Regional Settings)

Adjust these switches to specify the type of Coin Acceptor used and currency.

Default = SW1&SW2 ON - SR3 in parallel mode, Sterling.

| | |
|---------------------------|--|
| TEST BUTTON | Provides access to the TEST MENU when pressed. |
| SERVICE BUTTON | Provides a SERVICE CREDIT when pressed |
| Status LED | Flashes when functioning. |
| CHANNEL A | To Coin Acceptor (SR3 TYPE.) |
| DIL SW1 (credit settings) | Adjust to required price of pay. |
| DEMAG | NOT USED |
| VOL CONTROL A | MAIN VOLUME ADJUSTMENT (FRONT SPEAKERS) |
| VOL CONTROL B | SECONDARY VOL ADJUSTMENT (GUN SPEAKERS) |
| VOL CONTROL C | NOT USED |

13 LAMPS AND LIGHTING

⚠ WARNING

- When working with the product, be sure to turn the power off. Working with the power on may cause an electric shock or short circuit.
- You may get burned by a hot fluorescent lamp or other lamps. Pay full attention to the lamps when performing work.
- Be sure to use lamps of the designated rating. Using lamps of undesignated rating can cause fire or malfunctioning.
- There is the danger of short circuits or smoke generation due to deterioration of insulation in lighting fixtures resulting from age deterioration. Check for anomalies such as the following: Does it smell like something is burning? Is there socket discoloration? Are any lamps being replaced frequently? Do lamps not go on properly?

⚠ CAUTION

The Coin Door Lamp utilises a 12v 1.2w Wedge Bulb. It is important that you replace this bulb or any other bulb of that of the same voltage and rating. Failing to observe this caution may result in PCB failure or possible fire hazard.

13-1 COIN DOOR LAMP

Step 1. Open the Coin Door and locate the Lamp Housing directly behind the Coin Insert Bezel. 

Step 2. Hold the Lamp Housing firmly between your index finger and thumb and gently pull upwards. Do not try to remove the Lamp Housing whilst holding the bulb as the bulb may break causing injury.

Step 3. Once the Lamp Housing has been removed, carefully hold the bulb between your fingers and pull the Lamp Housing away.

Do not twist either bulb or Lamp Housing whilst removing the bulb as this may cause damage to both bulb and/or Housing.

Type: Wedge Bulb - 12v, 1.2w

Step 4. Simply push-fit a replacement bulb of the same type and follow these steps in reverse to refit.

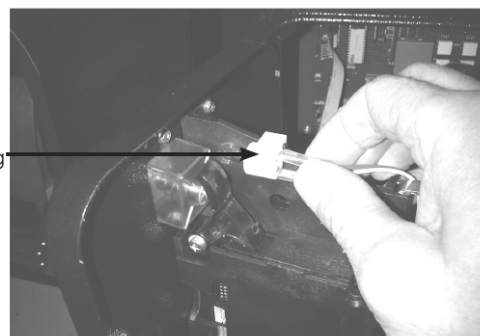

13-2 START/VIEW BUTTON PANEL

- 1 Turn off the power.
- 2 Remove the (4) M4x16 Hex Key machine screws from the START/VIEW Button Panel.

MSCR HEX (4)
M4x16

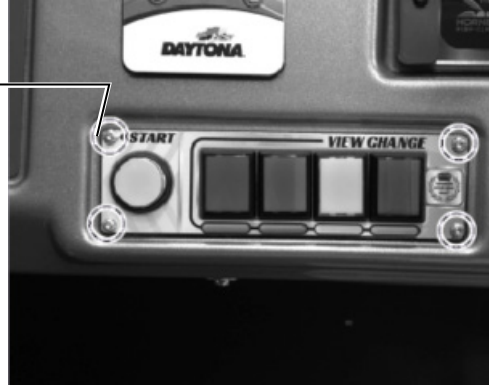

- 3 Remove the START/VIEW button panel part way to gain access to the connector. Disconnect the connector and remove.

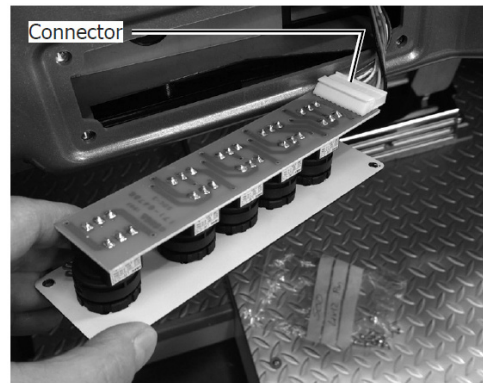

- 4 There is a metal clasp fitted at the base of each button. Rotate this metal clasp to unlock it, then remove the printed circuit board from the button plate.

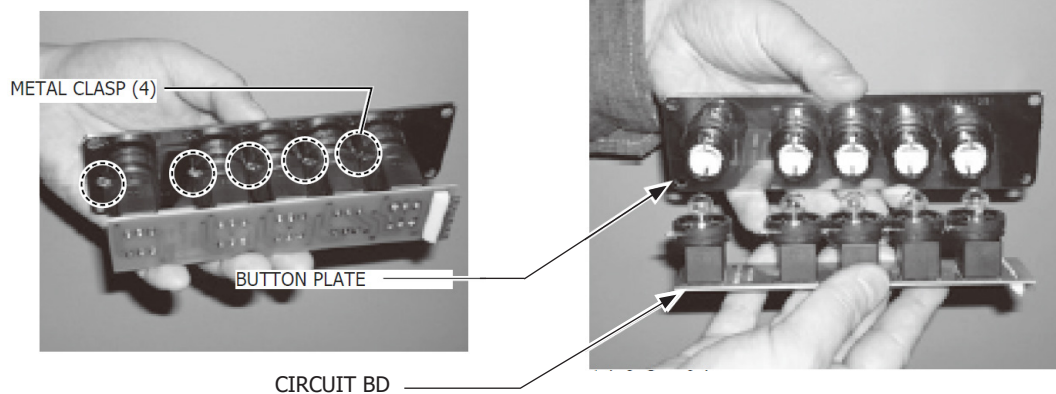

-
- 5** Carefully press on the lamp and turn it counter clockwise to remove.

LAMP 6.3V, 1W

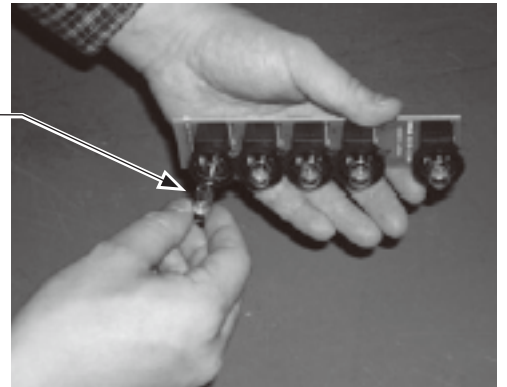

-
- 6** Follow these instructions in reverse order to re-assemble and re-fit the START/VIEW Button Panel..

13-3 FOOTWELL LIGHTING

The FOOTWELL LIGHTING provides an ambient coloured lighting effect to the FOOTWELL area. When the cabinets are joined in a network, each cabinet is assigned a different colour by means of illuminating various lighting around the cabinet. The FOOTWELL lighting forms part of this group.

- 1 Turn off the power.
- 2 Locate the Footwell lighting cover positioned beneath the Control Panel.

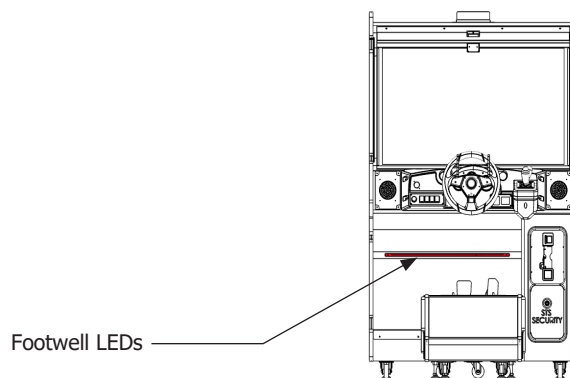

- 3 Remove the (2) M4x25 HEX KEY MSCR located at either end of the FOOTWELL LIGHTING COVER. Locate the LED strip and carefully peel away from the surface.

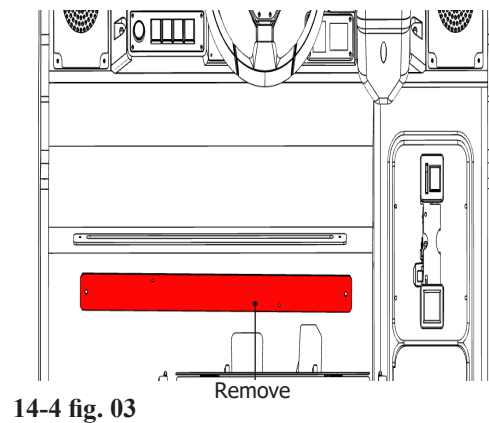
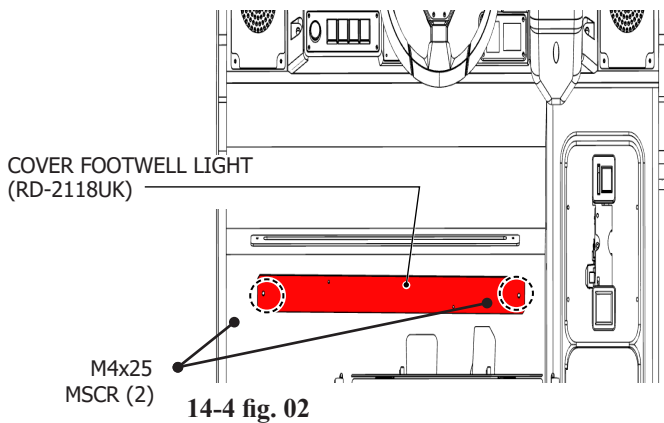

FLEX STRIP RGB LED 20CM
390-2012-020RGB

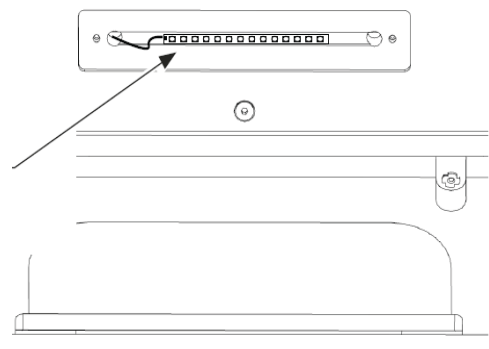

4 Remove the BACK DOOR of the DISPLAY CABINET. Locate and disconnect the connector for the FOOTWELL LED STRIP.

(2) Unlock the Back door using the back door key (supplied)

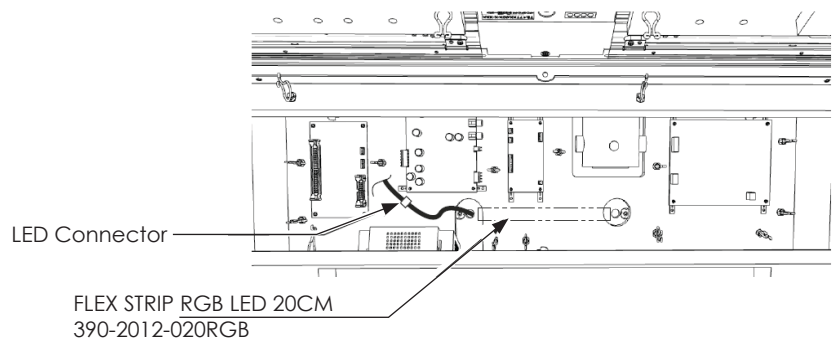
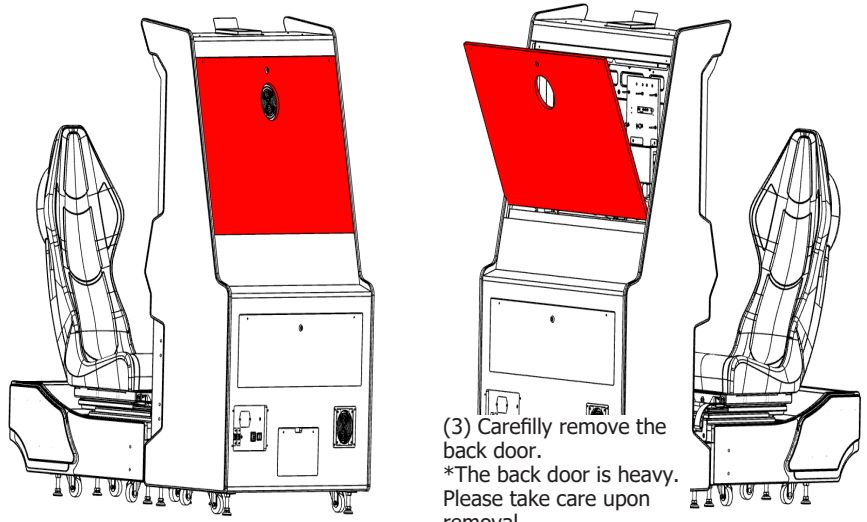

5 Carefully pull the LED STRIP through the access hole and discard. Fit a NEW LED STRIP by following these instructions in reverse order.

13-4 INNER PANEL LIGHTING

- 1 Turn off the power.
- 2 Unlock and remove upper back door..

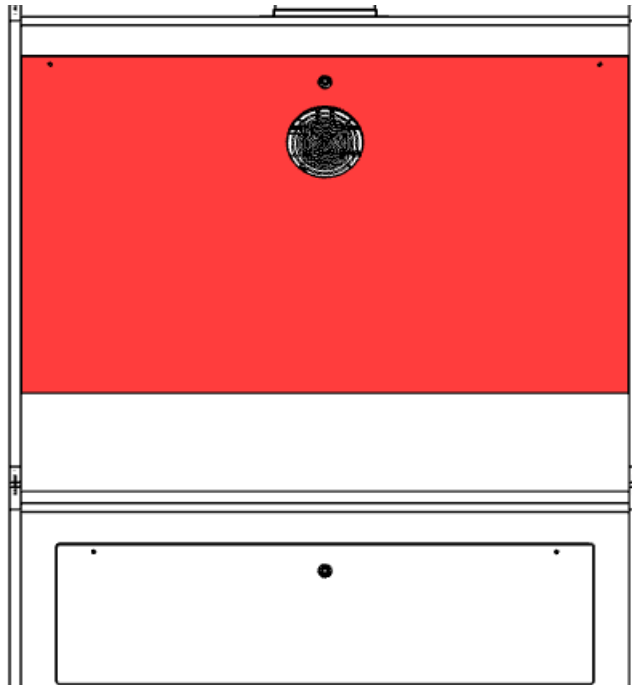

- 3 Remove the (3) M4 fixings highlighted.

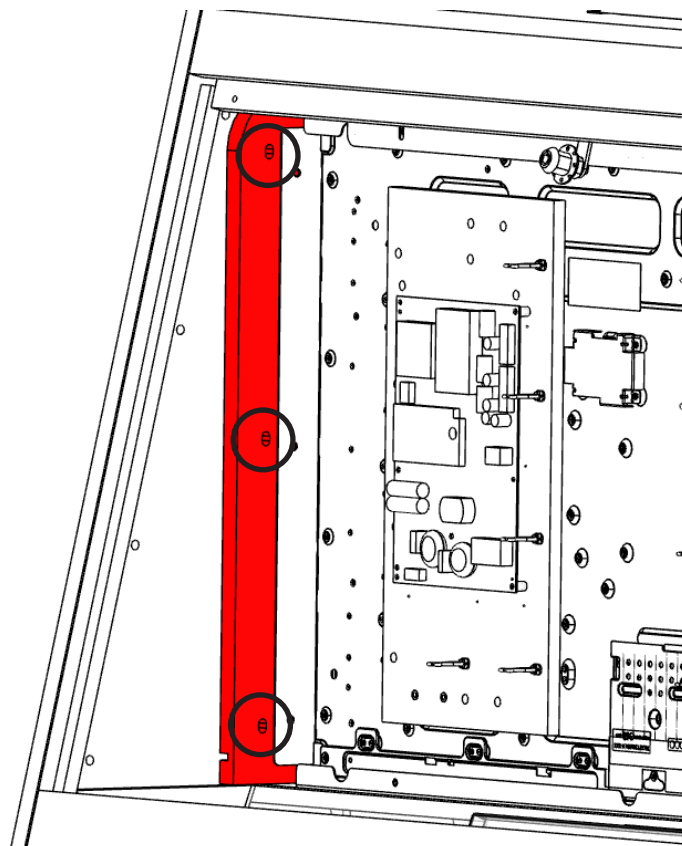

4 Slide the INNER PANEL out and away from the cabinet.

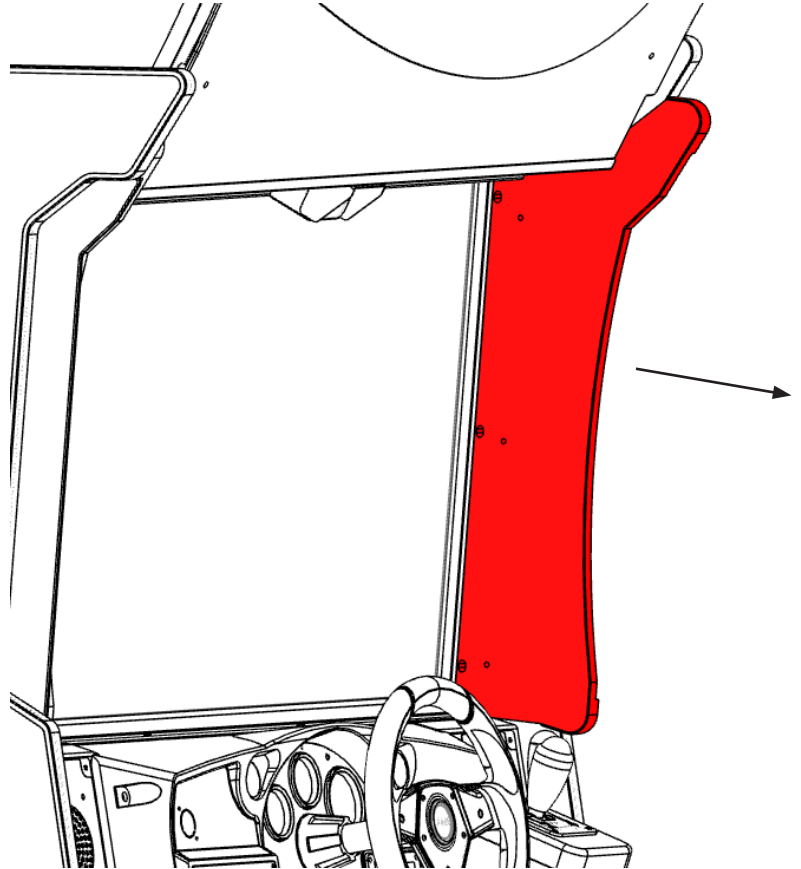

5 Replace the faulty LED strip on the inner side of INNER PANEL.

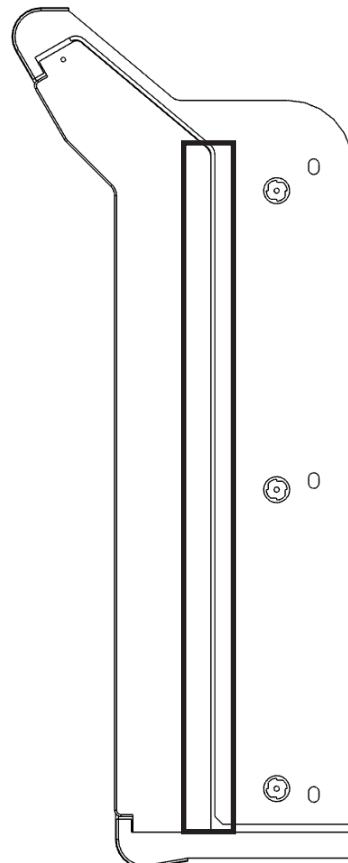

13-5 SEAT RING LIGHTING

- 1 Turn off the power.
- 2 Remove (4) M4 fixings highlighted and remove SEAT RING DISC..

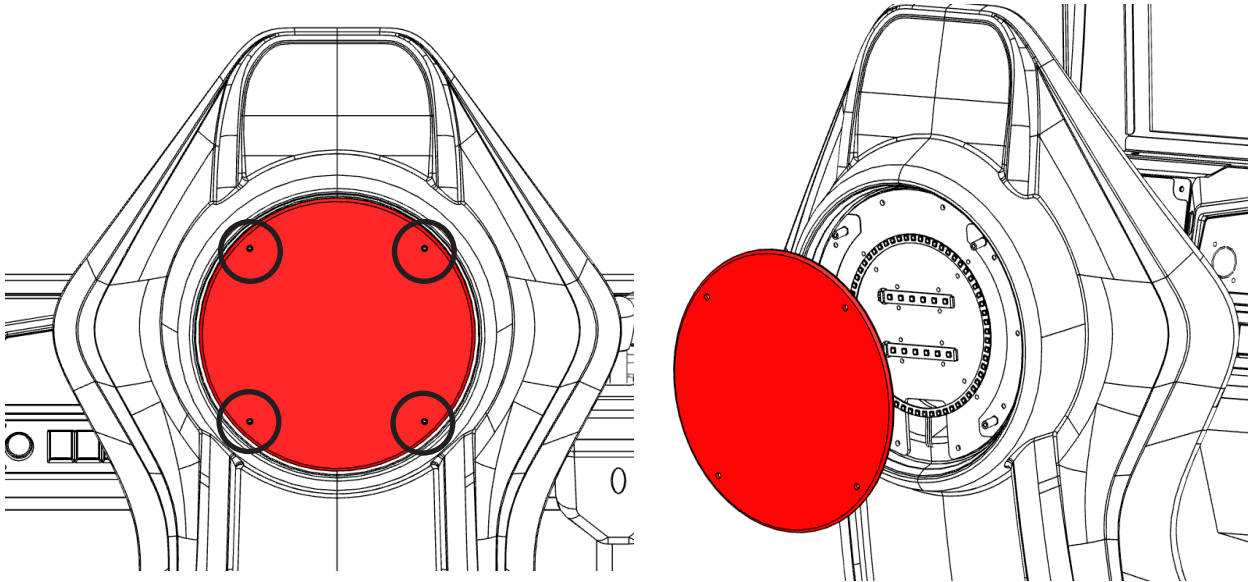

- 3 Remove and replace any faulty LED strips.

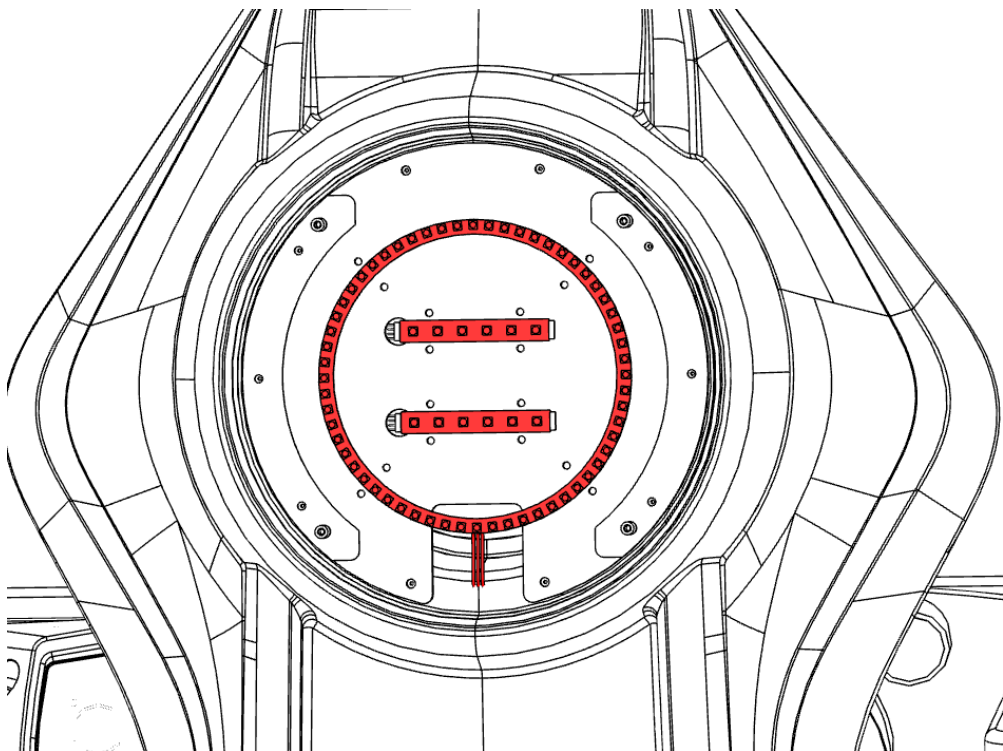

- 4 Resecure by following steps in reverse

13-6 BILLBOARD LIGHTING

- 1 Turn off the power.
- 2 Remove (2) M4 fixings highlighted and remove BILLBOARD BUMPER.

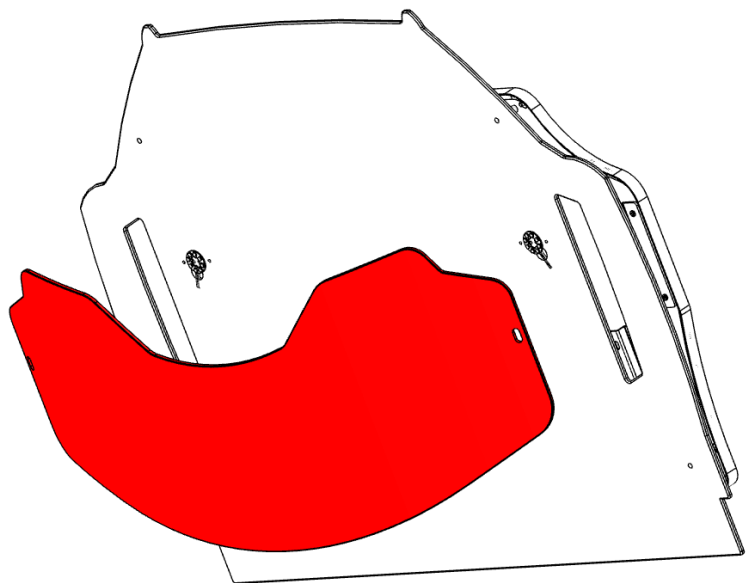
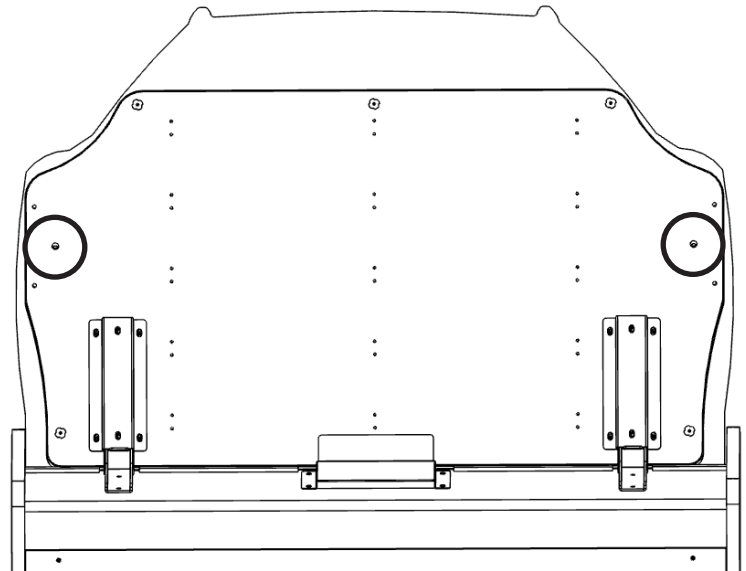

3 Remove and replace any and all faulty SLED RINGS.

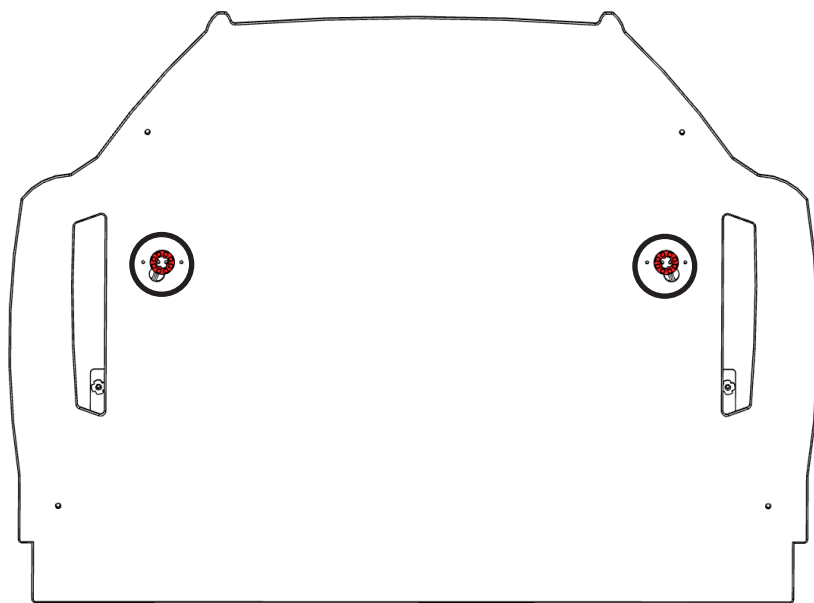

4 Resecure by following steps in reverse

13-7 UNDER SEAT LIGHTING

1 Turn off the power.

2 Remove (6) M4 fixings highlighted and remove COVER FLOOR LED.

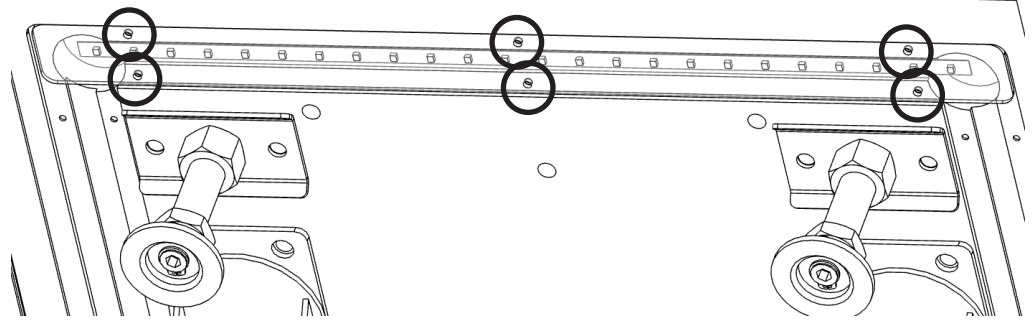

3 Remove and replace faulty LED strip.

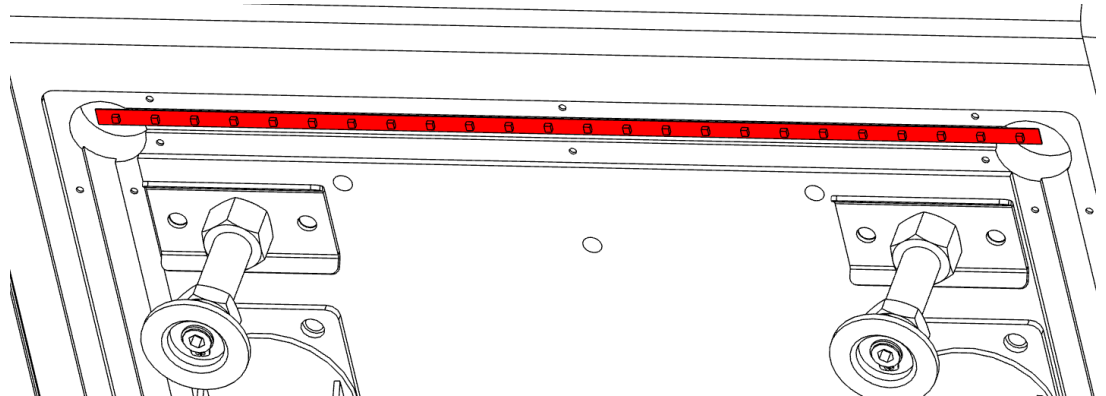

4 Resecure by following steps in reverse

14 PERIODIC INSPECTION

WARNING

- Once a year, check to see if power cords are damaged, if the plug is securely inserted, dust has not accumulated between the socket outlet and the power plug, etc. Using the product with accumulated dust in the interior may cause fire or electric shock.
- Never use a water jet, etc. to clean the inside and/or outside of the cabinet. If wetness occurs for any reason, do not use the product until it has completely dried.
- Once a year, request the office shown on this manual or the dealer from whom the product was originally purchased to perform the internal cleaning. Using the product with accumulated dust in the interior may cause fire or other accidents. Note that you are liable for the cost of cleaning the interior parts.
- There is the danger of accidents involving electrical short circuits or fire caused by factors such as the deterioration of insulation in electrical and electronic equipment over time. Check that there are no abnormalities such as odors from burning.

STOP IMPORTANT

When the game is not in use, check at regular intervals and make sure that nothing has been forgotten or placed on the seats.

WARNING

- Take care not to get fingers caught when opening/closing or attaching/removing doors, lids and other such parts.
- When working inside the cabinet, parts can catch causing cuts and abrasions. Check the inside of the cabinet and be aware of where the parts are before performing the work.

The items listed below require periodic checks and maintenance to guarantee the performance of this machine and to ensure safe operation.

Regularly clean all points of direct player contact such as the steering wheel and seat. Make regular inspections to ensure there is no damage to the surfaces and there are no foreign objects on the parts.

TABLE 15 PERIODIC INSPECTION TABLE

| ITEMS | DESCRIPTION | PERIOD |
|-----------------------------|--|---------------------------|
| CABINET | Confirm that adjusters contact floor | Daily |
| | Seat check, removal of forgotten / other items | Daily |
| LCD DISPLAY | Screen cleaning | Weekly |
| | Check screen adjustment | 1 month |
| | Exchange of lamp unit | When message is displayed |
| CONTROL UNIT | Cleaning | As appropriate |
| | Potentiometer Inspection | 1 month |
| | Greasing | 3 months |
| SEAT MECH | Cleaning | As appropriate |
| | Check for loose fixings | 3 months |
| | Greasing | 3 months |
| ACCEL/BRAKE | Potentiometer Inspection | 1 month |
| | Greasing | 3 months |
| COIN SELECTOR | Inspection of coin switch | 1 month |
| | Coin insertion test | 1 month |
| | Coin Selector cleaning | 3 months |
| GAME BOARD | Individual tests | 1 month |
| | Check of settings | 1 month |
| LAMPS AND LIGHTING | Inspection of lighting fixtures | As appropriate |
| ELECTRICAL/ELECTRONIC PARTS | Inspection | As appropriate |
| POWER CABLE | Inspection, Cleaning | 1 year |
| CABINET INTERIOR | Cleaning | 1 year |
| CABINET SURFACES | Cleaning | As appropriate |

Cleaning the Cabinet Surfaces

When the cabinet surfaces become dirty, remove stains with a soft cloth soaked in water or diluted (with water) chemical detergent and then wrung dry. To avoid damaging the finish, do not use such solvents as thinner, benzene, etc. (other than ethyl alcohol) or abrasives (bleaching agent and chemical dust-cloth).

Some general-purpose household, kitchen, and furniture cleaning products may contain strong solvents that degrade plastic parts, coatings, and print. Before using any cleaning product, read the product's cautionary notes carefully and test the product first on a small area that is not highly visible.

14-1 GREASING

GREASING SEAT RAIL

Move the seat to the rear most position and apply grease to the portion shown in the figure once every 3 months by using a good quality white lithium grease. After greasing, move the seat a few times forward and backward so as to allow the grease to be applied all over uniformly. Remove any residue from the protect rubbers and surrounding area..

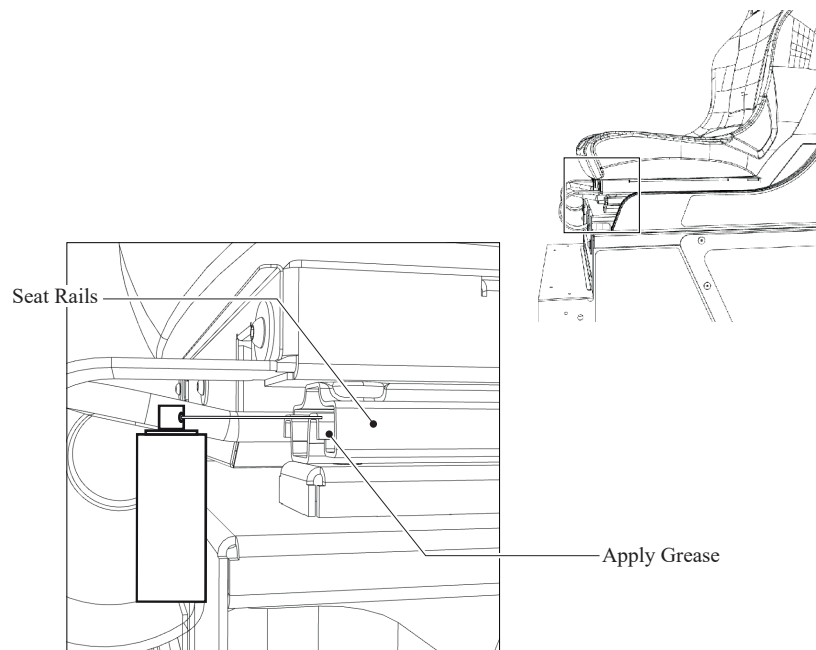

15-1 fig. 01

GREASING BRAKE&ACCEL

Remove the (4) fixings which secure the front and rear covers. Apply the lubricant to the areas shown. Be sure to apply a good quality synthetic lubricant. Using a mineral based lubricant may cause damage to plastic parts. Do not apply lubricant to parts other than those mentioned. Doing so may cause premature deterioration.

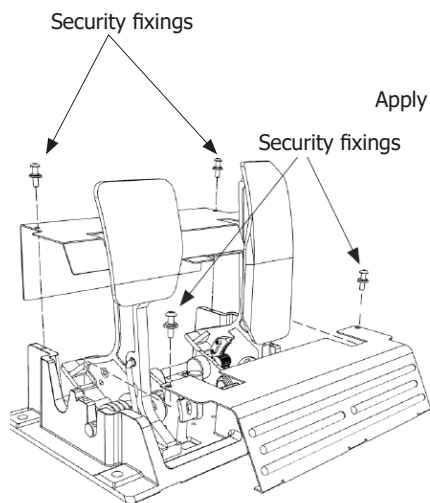

15-1 fig. 02

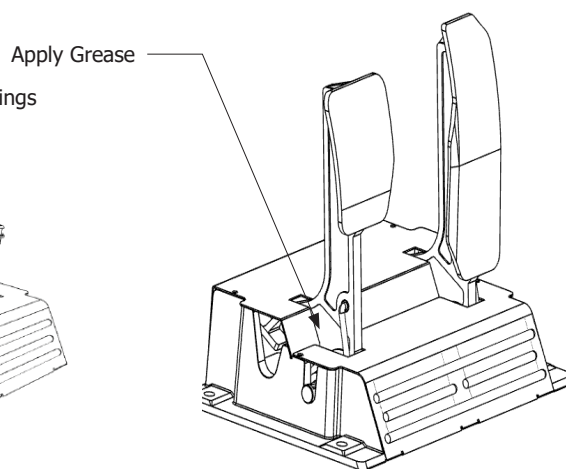

15-1 fig. 03

15 TROUBLESHOOTING & ERROR CODES

WARNING

- If an error message is displayed, have the problem looked at by a store maintenance person or a technician. Unless the problem is addressed by someone with specialized knowledge or skills, there could be electrical shock, short circuits or fire. If there are no store maintenance people or technicians, cut off the power immediately and contact the office shown in this manual or the dealer from whom the product was originally purchased.
- If problems other than those covered in this manual arise, or if no improvements can be noted after measures given in this manual have been taken, do not take measures indiscriminately. Cut off the power immediately and contact the office shown in this manual or the dealer from whom the product was originally purchased. Indiscriminate countermeasures could lead to unforeseeable accidents. They could also result in permanent damages.
- When working with the product, be sure to turn the power off. Working with the power on may cause an electric shock or short circuit.
- Be careful not to damage the wires. Damaged wires may cause an electric shock, short circuit or present a risk of fire.
- After the cause of circuit protector activation has been removed, have the circuit protector re-engaged. If the unit is used continuously as is, there could be heat generation or fire, depending on the cause of the activation.

CAUTION

- When removing and replacing parts, take due care not to trap or pinch your fingers.
- The Control Units contain gears, cams and other moving machine parts. Take due care not to trap or pinch your fingers.

TABLE 16 TROUBLESHOOTING TABLE

| PROBLEMS | CAUSE | COUNTERMEASURES |
|--|--|--|
| When the main SW is turned ON, the machine is not activated. | The power is not ON. | Firmly insert the plug into the outlet. |
| | Incorrect power source/voltage. | Make sure that the power supply/voltage are correct. |
| | The Circuit Protector of the AC Unit functioned due to momentary overcurrent. | After eliminating the cause of overload, have the Circuit Protector of the AC Unit restored. |
| | The screen is not adjusted correctly. | Adjust the screen correctly. |
| No sound output. | The audio level has not been correctly set with the Hardware Volume Control. | Adjust the Hardware Volume Control audio until the game can be heard. |
| | The volume levels within the Sound Settings in the Test Menu have not been set correctly. | Enter the Sound Settings menu from the Test Menu and check that all volume levels are set to the appropriate levels. Options are available within this menu to test the volume levels of each setting to make sure each are correct. |
| The Control Units (Steering wheel/Foot Pedals) do not operate correctly. | Due to external or environmental factors the targeting is off. | Perform calibration in TEST Mode. |
| | Volume damaged. (Potentiometer) | Exchange the volume. |
| The Foot pedals grind when operated or squeak. | Grease has deteriorated. | Apply grease to the designated grease areas. |
| The View buttons do not operate properly. | The Microswitch has been damaged or malfunctioned. | Replace the Microswitch. |
| | The connection to the Assy SW has broken. | Reconnect the connector |
| Control Unit does not respond. | The Control Unit motor is set not to move. | Alter the TEST Mode settings. (See 9.) |
| | Due to overload or other factors, an error has occurred with the motor. This has been sensed by the motor sensor and the motor has been stopped. | Remove the cause of the motor error. |
| | Motor damaged. | Exchange the motor. |
| The Control Unit makes a lot of noise when it vibrates. | Due to a problem with the vibration parts or wear over time, the internal parts are worn. | Replace motor. |
| The START switch does not operate | Faulty switch or bad connections | Check the connections on the rear of the switch. If connections are good, replace switch. |

| | | |
|--|---|--|
| Linked cabinets will not sync together in the attract mode. | Network cables are not connected. | Reconnect the network cables to each cabinet. |
| | The cabinets are using security keys from different regions | Ensure each cabinet has the same region (viewable on the System Information page of Test Mode). Cabinets will only link together from the same region. |
| | Network cables are faulty. | Replace the faulty network cables. Contact the company from whom the unit was purchased. |
| Cabinets are unable to start a Multi-player session together. | .Network cables are not connected. | Ensure network cables are properly connected to the cabinets. |
| | Cabinet ID's are not set up correctly. | Go into the Network Settings and ensure each cabinet has a different Cabinet ID. Confirm the settings and then the cabinets will reset with the new changes saved. |
| The Steering Wheel does not work correctly in the game. | The Steering Wheel has not been calibrated correctly. | Go into the Calibration Settings in the Test Menu and select Calibrate Steering. |
| The Pedals do not work correctly in the game. Vehicles move forward or backwards with no player input. | The Pedals have not been calibrated correctly. | Go into the Calibration Settings in the Test Menu and select Calibrate Brake and follow the on screen instructions. Once this has been done, select Calibrate Accelerator and follow the on screen instructions. |
| No audio can be heard in either the attract mode, or throughout the game. | The audio level has not been correctly set with the Hardware Volume Control. | Adjust the Hardware Volume Control until audio in the game can be heard. |
| | The volume levels within the Sound Settings in the Test Menu have not been set correctly. | Enter the Sound Settings menu from the Test Menu and check that all volume levels are set to the appropriate levels. Options are available within this menu to test the volume levels of each setting to make sure each are correct. |
| High Score Tables have not been cleared after attempting to clear them in the Bookkeeping menu. | The high scores have only been cleared on one cabinet when multiple cabinets are linked together. | When multiple cabinets are linked together, the high score tables will only be cleared if the process is done on all connected machines at the same time. Each cabinet must be in the Bookkeeping menu, and then Clear High Scores should be selected on each one and then confirmed. If any cabinets are left in the attract mode during this, the high score tables will not be cleared. |

| | | |
|--|--|--|
| The Camera is not detected/ operating | The camera is connected into the wrong USB port | Make sure the camera is connected into the USB3 port on the CPU. (The USB3 port is identified by its 'blue' colour). The camera will not operate in a standard USB port. |
| | Bad connections | Check that good connections are made in the camera ,USB cable, and camera Ext. cable. |
| | Camera faulty | Replace camera. |
| An error message appears in the game that says: "I/O BOARD NOT DETECTED". | The I/O USB cable has become disconnected. | Reconnect the I/O USB cable to the game board and perform a power cycle. |
| An error message appears in the game that says: "SECURITY KEY NOT DETECTED". | The security key has become dis- connected. | Reconnect the security key to the game board and perform a power cycle. |

TABLE 16-1 ERROR MESSAGE TABLE

The game is equipped with an integral fault monitoring system. Each time an identified fault is detected an error message is displayed on screen.

Below is a table showing possible common conditions. Please refer to them as a guide.

If the ERROR Code/Message displayed on screen is not supported by this manual then please contact your Sega Service Centre for diagnostics.

| ERROR MESSAGE | DESCRIPTION | TROUBLESHOOTING |
|--------------------------------|---|--|
| Error - No Security Key Found | The system was unable to detect a valid security key | Check USB Security Key |
| Error - Incorrect Key Inserted | The system found a security key but the configuration is not valid for this product | Check USB Security Key |
| Error - Security Failure | The system security has detected security issues with the installed software | Restore software from recovery USB stick |
| Error - I/O BD failure | The I/O Board was not detected on power up | Check I/O Board, Power supply and harnessing |
| Error - I/O BD disconnected | The IO Board was detected on power up, but has subsequently been disconnected from the software | Check I/O Board, Power supply and harnessing |
| Error - Update Copy Failed | The shell was unable to create main and backup copies of the game or during install or update | Check USB Install Media and re-apply update or re-install. If still failing restore software from USB Recovery stick |
| Error - Invalid Shell Update | The shell Update on the USB stick is not a valid update | Check USB Install Media and re-apply update |
| Error - Update Copy Fail | The shell was unable to create main and backup copies of the game or during install or update | Check USB Install Media and re-apply update or re-install. If still failing restore software from USB Recovery stick |
| Error - No Game Installed | The shell was unable to find a game on the disk to launch. A game needs to be installed. | Restore software from USB Recovery stick |
| Error - No Shell Installed | Launcher was unable to find a Shell on the disk to launch. A Shell needs to be installed. | Restore software from USB Recovery stick |
| Game Error | The game was unable to launch or has terminated abnormally. On reboot the game will be reinstalled from back up. If it fails again no further attempt to launch the game will be made on subsequent power cycles. | Restore software from USB Recovery stick |

16 GAME BOARD

WARNING

- When working with the product, be sure to turn the power off. Working with the power on may cause an electric shock or short circuit.
- Be careful not to damage the wires. Damaged wires may cause electric shock or short circuit or present a fire risk.
- Do not expose the game board, etc. without a good reason. Failure to observe this can cause electric shock hazard or malfunctioning.
- Do not use this product with connectors other than those that were connected and used with the game board at the time of shipping. Do not carelessly connect wires to connectors that were not used at the time of shipping, as this may cause overheating, smoke or fire damage.
- When returning the game board after making repairs or replacements, make sure that there are no errors in the connection of connectors. Erroneous connections can lead to electrical shock, short circuits or fires.
- When connecting a connector, check the direction carefully. Connectors must be connected in only one direction. If indiscriminate loads are applied in making connections, the connector or its terminal fixtures could be damaged, resulting in electrical shock, short circuits or fires.

CAUTION

- In this product, setting changes are made during the test mode. The game board need not be operated. Use the game board, etc. as is with the same setting made at the time of shipment so as not to cause electric shock and malfunctioning.
- Static electricity from your body may damage some electronic devices on the IC board. Before handling the IC board, touch a grounded metallic surface so that the static electricity can be discharged.

IMPORTANT

- When replacing the Game Bd. Remove all external USB devices before packaging it up and returning it to your Service Center. The replacement Game BD will not come with these devices fitted.
- When sending the Game Bd for repair, send it complete along with any external USB devices. Do not send the Game Bd with USB devices connected. Leaving the USB devices connected may cause damage.
- Make sure the Game BD is packaged in suitable box and protected using a cushioned filler. Sending the Game BD without suitable packaging may cause further damage which in turn will incur further repair costs.

16-1 HOW TO REMOVE GAME BOARD

The game board located at the rear of the cabinet behind the screen. Each cabinet has it's own Game Board.

1 Turn the power off..

2 Remove the PANEL ACCESS DOOR by unscrewing the (2) M4x25 SKT BH PAS Screws located at each top corner.

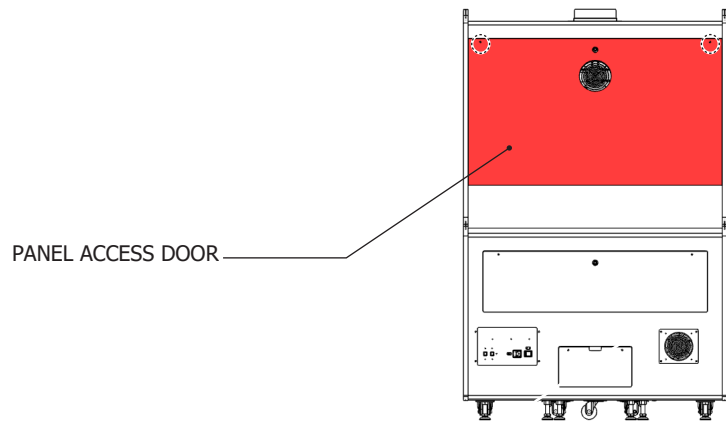

17-1 fig. 01

3 Unlock back panel by using key provided (keyhole labelled).

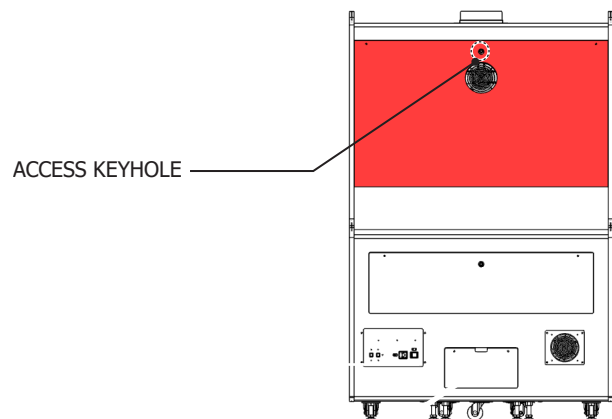

17-1 fig. 02

4 Carefully disconnect all of the connectors connected to the Game Bd. Please refer to the next section in this manual, 16.2 Game Board Connectors.

- 5** Locate and remove the (2) M4x25 SKT BH PAS fixings which secure the SASH BACK GAME BD to the Cabinet.

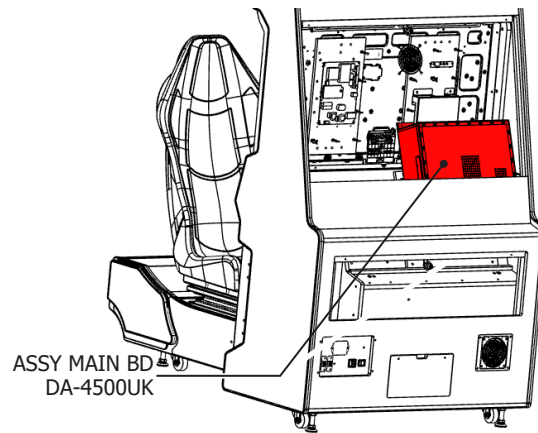

17-1 fig. 03

- 6** Locate and remove the (4) M4x25 SKT BH PAS fixings which secure the SASH BACK GAME BD to the backing board.

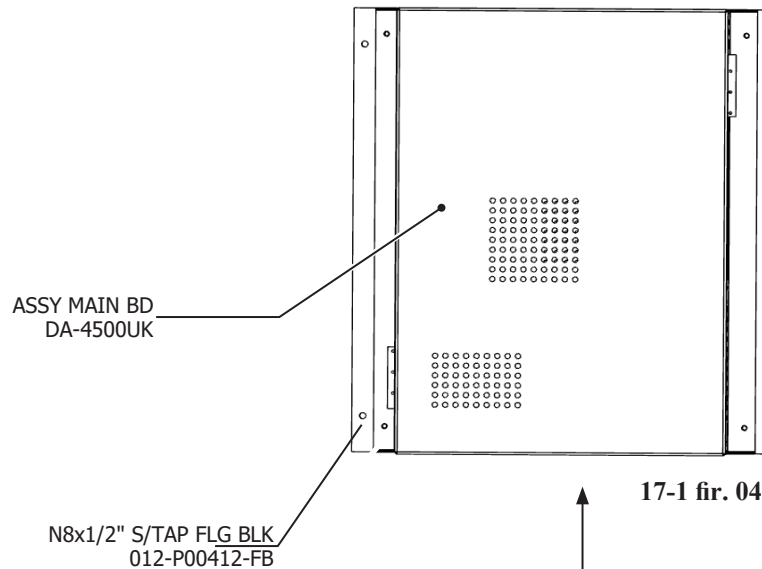

17-1 fir. 04

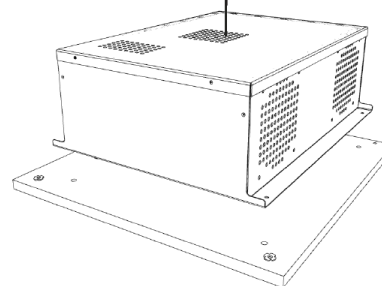

17-1 fig. 05

- 7** Replace the ASSY MAIN BD by following these instructions in reverse order.

16-2 GAME BOARD CONNECTORS

There are many connections to be made at the GAME BD. Although similar to a home personal computer in appearance, there are a few differences. Please be sure that each connection is made in the same position when disconnecting and reconnecting the Game Bd. Failing to make the same connections may result in malfunction.

16 GAME BOARD

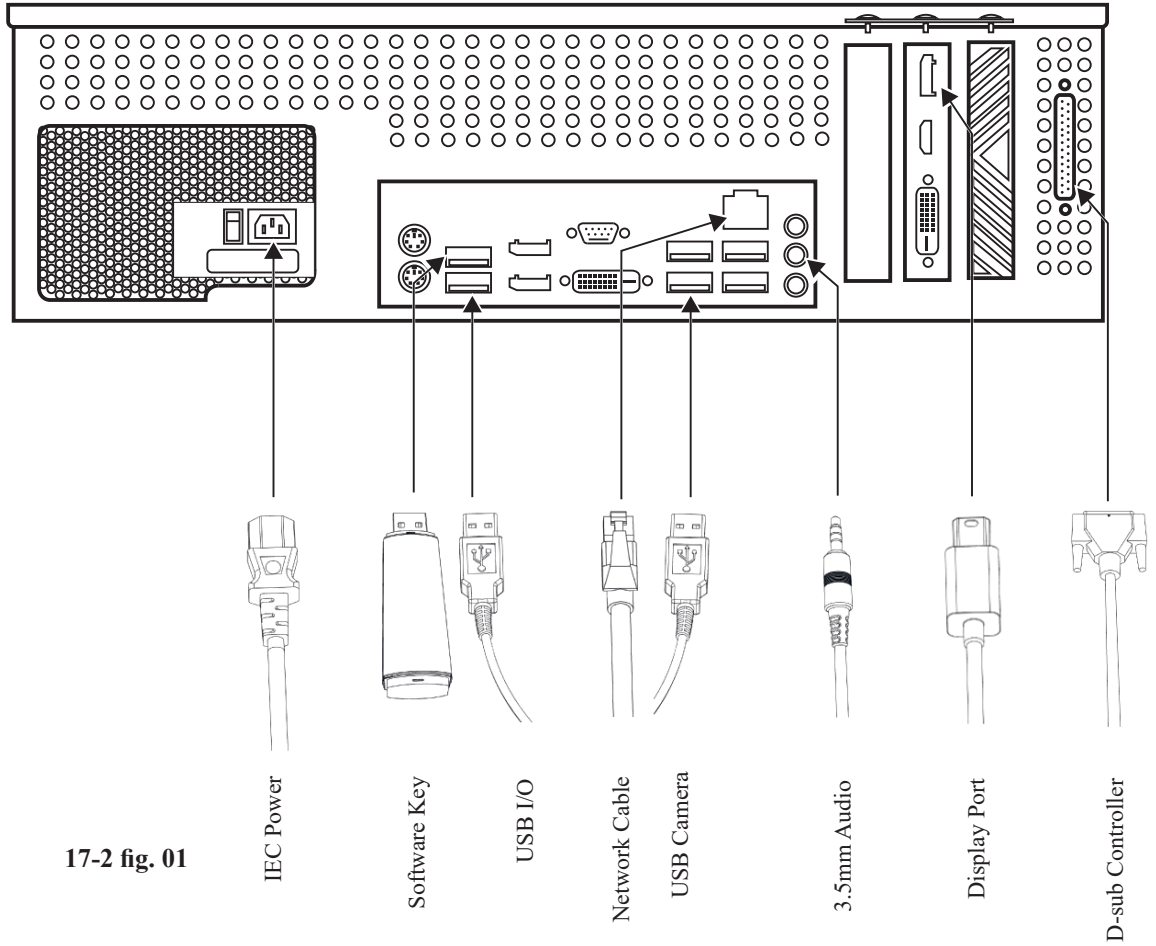

17-2 fig. 01

17 DESIGN RELATED PARTS

For the warning display stickers, refer to Section 1.



DA-7722UK



DA-7727UK



DA-7724UK



DA-7101UK



DA-7102UK



DA-7809UK



DA-7812UK

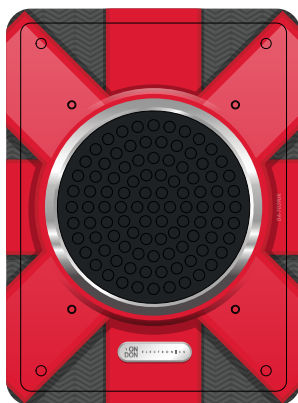

DA-7059UK



DA-7729UK



DA-7728UK

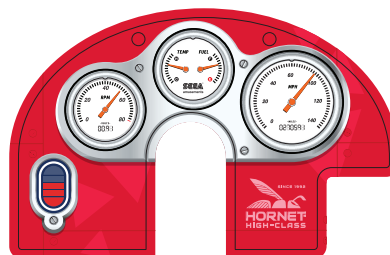

DA-7201-BUK

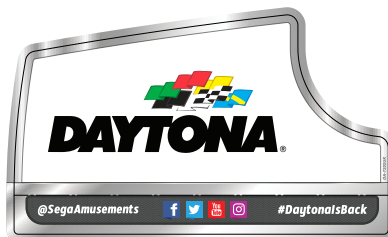

DA-7202UK

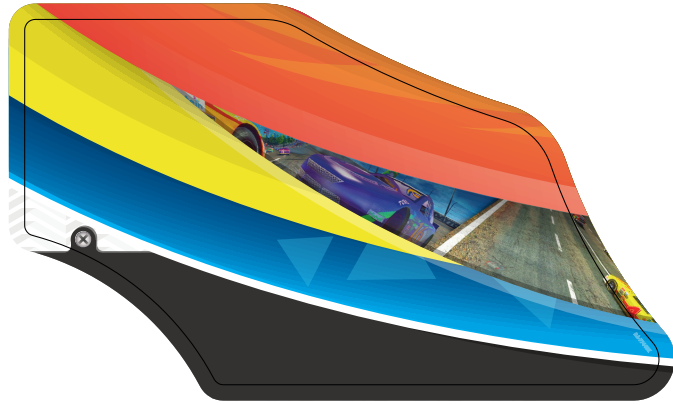

DA-7734UK

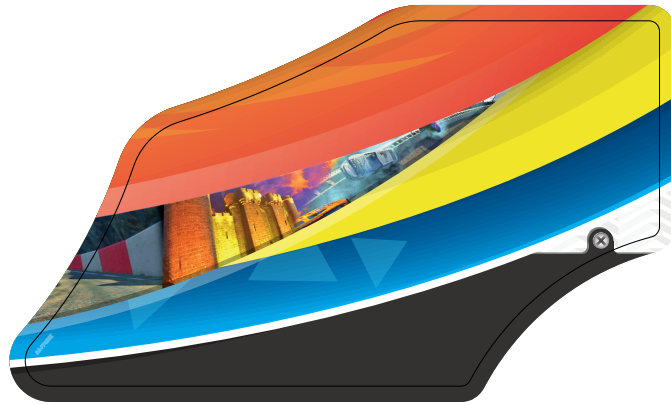

DA-7744UK



DA-7725UK



DA-7726UK

18 PARTS LIST

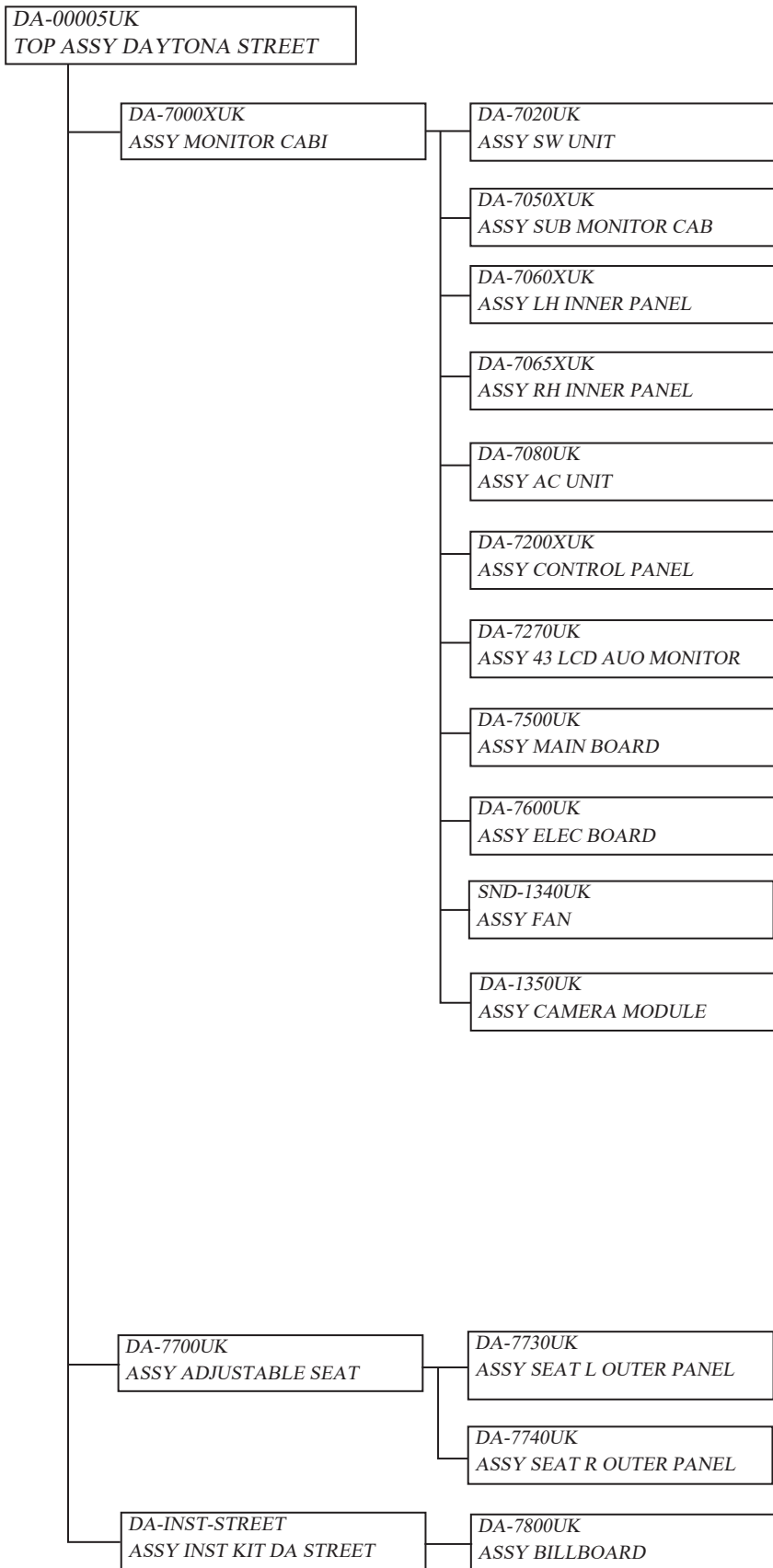

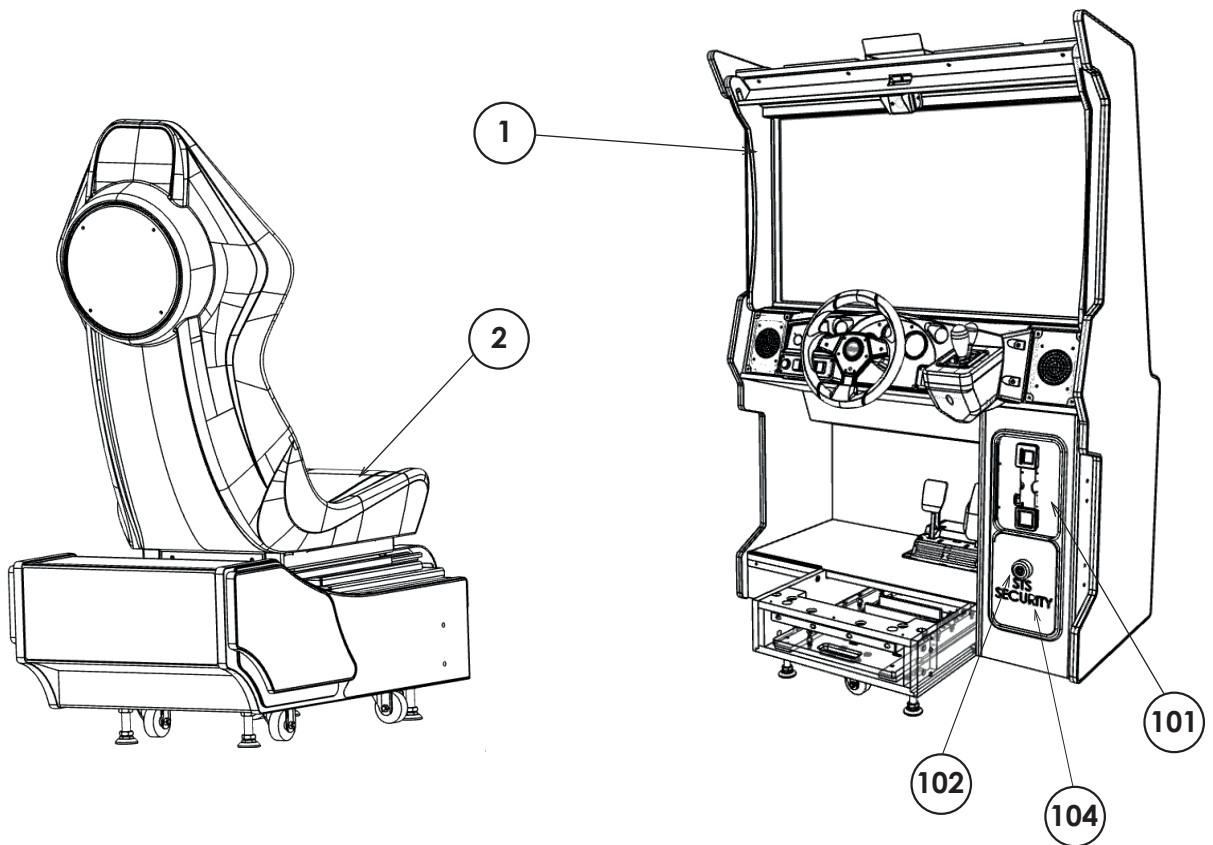

| SEQ | PT NUMBER | DESCRIPTION | REFERENCE | QTY |
|------|----------------|-------------------------------------|-----------|-----|
| *1 | DA-7000XUK | ASSY MONITOR CABINET | | 1 |
| *2 | DA-7700UK | ASSY ADJUSTABLE SEAT | | 1 |
| *20 | 421-7988-91UK | STICKER SERIAL NUMBER UK | | 1 |
| *21 | 440-CS0010UK | STICKER CAUTION GENERIC | | 2 |
| *22 | 440-DS0010UK | STICKER DANGER HIGH VOLTAGE | | 2 |
| *23 | 440-WS0010UK | STICKER WARNING HI-VOLTAGE | | 1 |
| *24 | 440-WS0100UK | STICKER WARNING FORK HERE | | 4 |
| *25 | LB1046 | LABEL TESTED FOR ELEC. SAFETY | | 1 |
| *26 | LB1130 | LABEL WEEE WHEELIE BIN | | 1 |
| *101 | 220-5374-01 | DOOR DFMD W/FR&LOCK C120 UNIV | | 1 |
| *102 | 220-5575UK | LOCK (J9117) KEY TO LIKE 22MM W CAM | | 1 |
| *103 | OS1247 | ALUMINIUM STICKY CLIP ASK-3 | | 3 |
| *104 | 220-5727-01B | DOOR CASH H.S. STS | | 1 |
| *401 | DA-INST-STREET | ASSY INST KIT DA STREET | | 1 |
| *402 | SAECE-xxx | DECLARATION OF CONFORMITY | | 1 |
| *403 | PK0468 | SHRINK WRAP RD STD | | 2 |
| *404 | PK0518 | PALLET DA STREET MONITOR | | 1 |
| *405 | PK0519 | PALLET DA STREET SEAT | | 1 |
| *406 | 420-0028-02UK | MANUAL DA STREET | | 1 |

Please note: The location of all labels can be found in Chapter 1 of this manual.

② ASSY MONITOR CABI (DA-7000XUK)

(D-1/2)

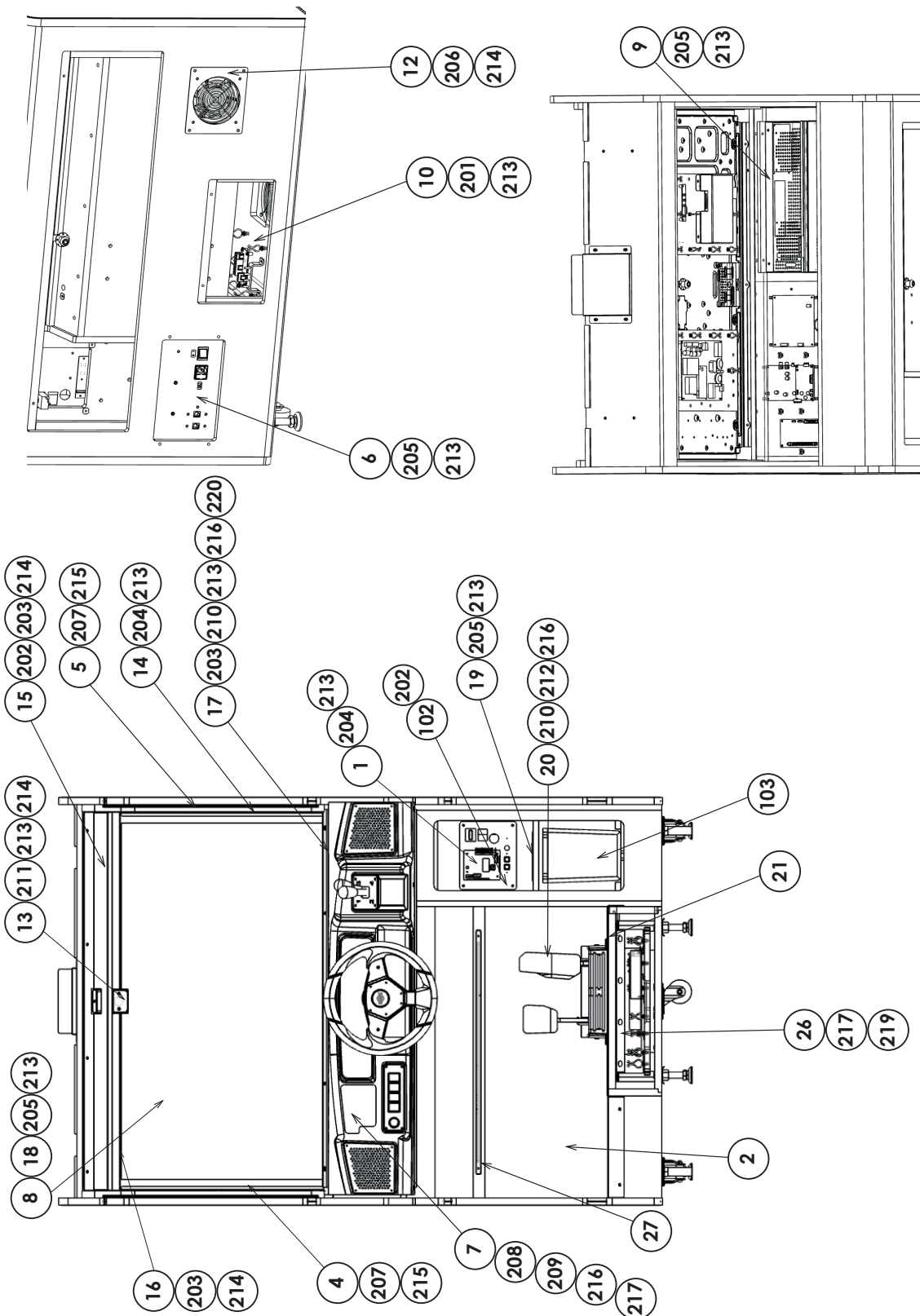

| ITEM NO | PART NO | DESCRIPTION | REFERENCE | QTY |
|---------|-----------|----------------------|-----------|-----|
| **1 | DA-7020UK | ASSY SW UNIT | 1 | 1 |
| **2 | DA-7050UK | ASSY SUB MON 42"CABI | 9 | 1 |
| **3 | DA-7055UK | ASSY SPEAKER GRILLE | 12 | 2 |
| **4 | DA-7060UK | ASSY LH INNER PANEL | 10 | 1 |
| **5 | DA-7065UK | ASSY RH INNER PANEL | 14 | 1 |
| **6 | DA-7080UK | ASSY AC UNIT | 6 | 1 |
| **7 | DA-7200UK | ASSY CONTROL PANEL | 1 | 1 |

② ASSY MONITOR CABI (DA-7000XUK)

(D-2/2)

| ITEM NO | PART NO | DESCRIPTION | REFERENCE | QTY |
|---------|-----------------|----------------------------------|-----------|-----|
| **8 | DA-7270UK | ASSY 43" LCD AUO MONITOR | | 1 |
| **9 | DA-7500UK | ASSY MAIN BD | | 1 |
| **10 | DA-7600UK | ASSY ELEC BD | | 1 |
| **11 | DA-7900UK | ASSY AUX ELEC BD | | 1 |
| **12 | SND-1340UK | ASSY FAN | | 1 |
| **13 | DA-1350UK | ASSY CAMERA MODULE | | 1 |
| **14 | DA-7003UK | BRKT GLASS RETAIN SIDE | | 2 |
| **15 | DA-7004UK | BRKT BB HEADER BTM | | 1 |
| **16 | DA-7005UK | BRKT GLASS RETAIN TOP | | 1 |
| **17 | DA-7006UK | BRKT GLASS RETAIN BTM | | 1 |
| **18 | DA-7279UK | GLASS LCD 43" AUO SCREEN PROTECT | | 1 |
| **19 | DUT-0302UK | PLATE COIN PATH | | 1 |
| **20 | SPG-2200-01-CN | ASSY ACCEL & BRAKE CHINA | | 1 |
| **21 | SPG-2224UK | PEDAL GASKET | | 1 |
| **22 | DA-7101UK | STICKER LH CHEEK | | 1 |
| **23 | DA-7101-AUK | BLANK STICKER LH CHEEK | | 1 |
| **24 | DA-7102UK | STICKER RH CHEEK | | 1 |
| **25 | DA-7102-AUK | BLANK STICKER RH CHEEK | | 1 |
| **26 | DA-7009UK | BRKT FRONT JOINT | | 1 |
| **27 | DA-7066UK | COVER FOOTWELL LIGHT | | 1 |
| **28 | DA-7007UK | BRKT JOINT INNER L | | 1 |
| **29 | DA-7008UK | BRKT JOINT INNER R | | 1 |
| **101 | 130-04030-E | SPKR ELIP 40HM 30W VIS DX4x6P | | 2 |
| **102 | 838-8001UK | AMP 2.2 VISATON | | 1 |
| **103 | PP1087 | BOX CASH | | 1 |
| **104 | 280-A012640-WX | ROUTER TWIST D12 SO6.4 WOOD XL | | 58 |
| **105 | 390-2012-060RGB | LED FLEXIBLE RGB 600MM | | 1 |
| **201 | 000-P00450 | M4X50 MSCR PAN PAS | | 2 |
| **202 | 012-P03512-F | N6X1/2" S/TAP FLG PAS | | 4 |
| **203 | 029-B00412-0B | M4X12 SKT BH BLK | | 11 |
| **204 | 029-B00416 | M4X16 SKT BH PAS | | 10 |
| **205 | 029-B00425 | M4X25 SKT BH PAS | | 17 |
| **206 | 029-B00425-0B | M4X25 SKT BH BLK | | 12 |
| **207 | 029-B00630-0B | M6X30 SKT BH BLK | | 6 |
| **208 | 029-B00816 | M8X16 SKT BH PAS | | 4 |
| **209 | 029-B00825 | M8X25 SKT BH PAS | | 4 |
| **210 | 029-B00840 | M8X40 SKT BH PAS | | 4 |
| **211 | 050-U00400 | M4 NYLOC NUT | | 3 |
| **212 | 060-S00800 | M8 WSHR SPR PAS | | 8 |
| **213 | 068-441616 | M4 WSHR 16OD FLT PAS | | 4 |
| **214 | 068-441616-0B | M4 WSHR 16OD FLT BLK | | 36 |
| **215 | 068-652016-0B | M6 WSHR 20OD FLT BLK | | 16 |
| **216 | 068-852216 | M8 WSHR 22OD FLT PAS | | 6 |
| **217 | 020-F00830-0B | M8X30 SKT CSK BLK | | 8 |
| **218 | 029-B00830 | M8X30 SKT BH PAS | | 4 |
| **219 | 020-F00850-0B | M8X50 MSCR SKT CSK BLK | | 4 |
| **220 | 050-F00800 | M8 NUT FLG SER PAS | | 8 |
| **301 | DA-60104UK | WH AC MONITOR / DBA | | 1 |
| **302 | DA-60108UK | WH PEDALS | | 1 |
| **304 | DA-60115UK | WH SPEAKERS / LIGHTING | | 1 |
| **305 | DA-60117UK | WH CTRL TO BILLBOARD | | 1 |
| **306 | DA-60118UK | WH AUDIO VISATON | | 1 |
| **307 | DA-60121UK | WH CTRL TO BASE | | 1 |
| **308 | BE-6001UK | ASSY LED CLIP | | 1 |

③ ASSY SW UNIT (DA-7020UK)

(D-1/1)

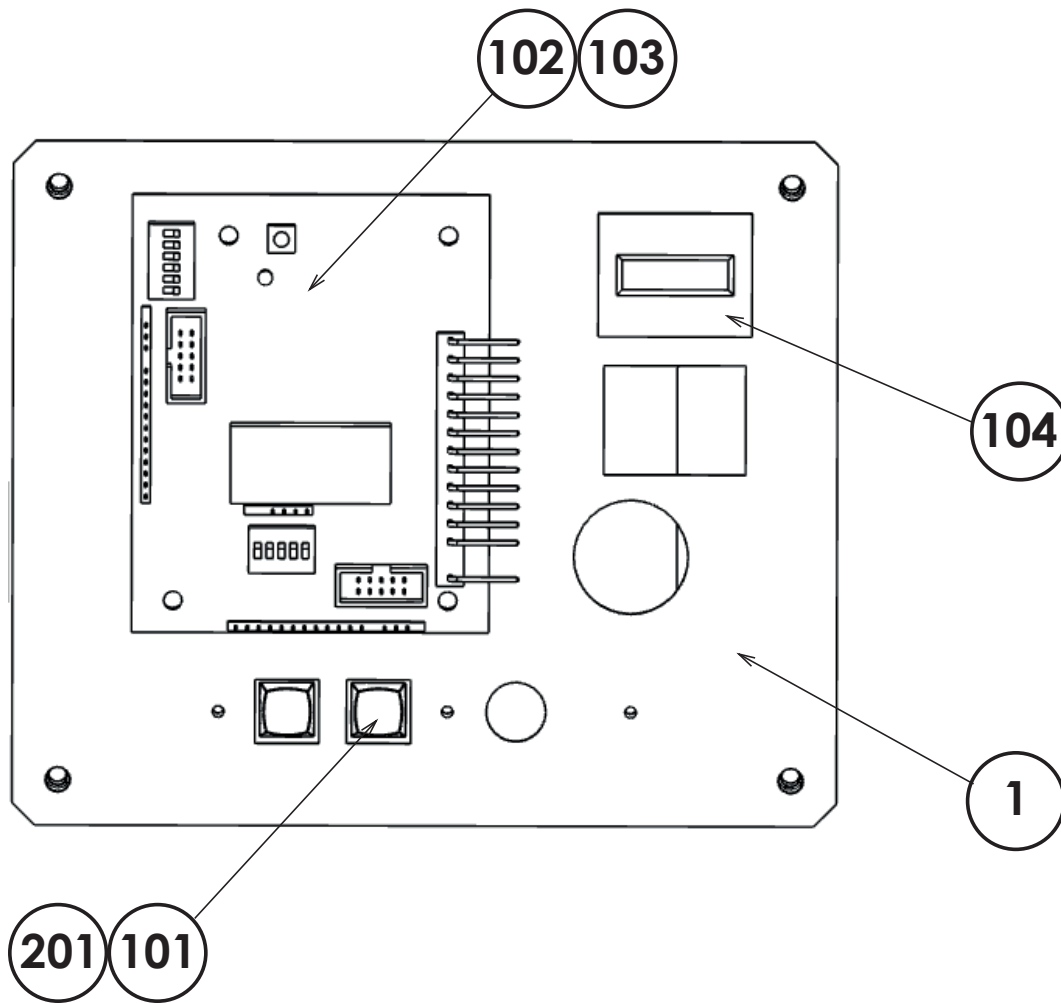

| ITEM NO | PART NO | DESCRIPTION | REFERENCE | QTY |
|---------|-----------------|------------------------|-----------|-----|
| ***1 | SSR-0321UK | SW BRKT DOUBLE METER | | 1 |
| ***101 | 838-14548-01AUK | SW & VOL CTL BD | | 1 |
| ***102 | 280-L00706-PM | STANDOFF 6.4MM HOLE PM | | 4 |
| ***103 | EP1380-01 | CREDIT BOARD EXCEL | | 1 |
| ***104 | 220-5643UK | COIN METER SMALL 12V | | 1 |
| ***106 | 421-12043-01 | STICKER SW PANEL CE | | 1 |
| ***107 | OS1098 | CRIMP BELL END SMALL | | 2 |
| ***108 | 601-0460 | CABLE TIE NYLON 100MM | | 2 |
| ***201 | 029-B00308 | M3X8 SKT BH PAS | | 3 |
| ***301 | DA-60110 | WH COIN HANDLING | | 1 |

④ ASSY SUB MONITOR CABI (DA-7050XUK)

(D-1/2)

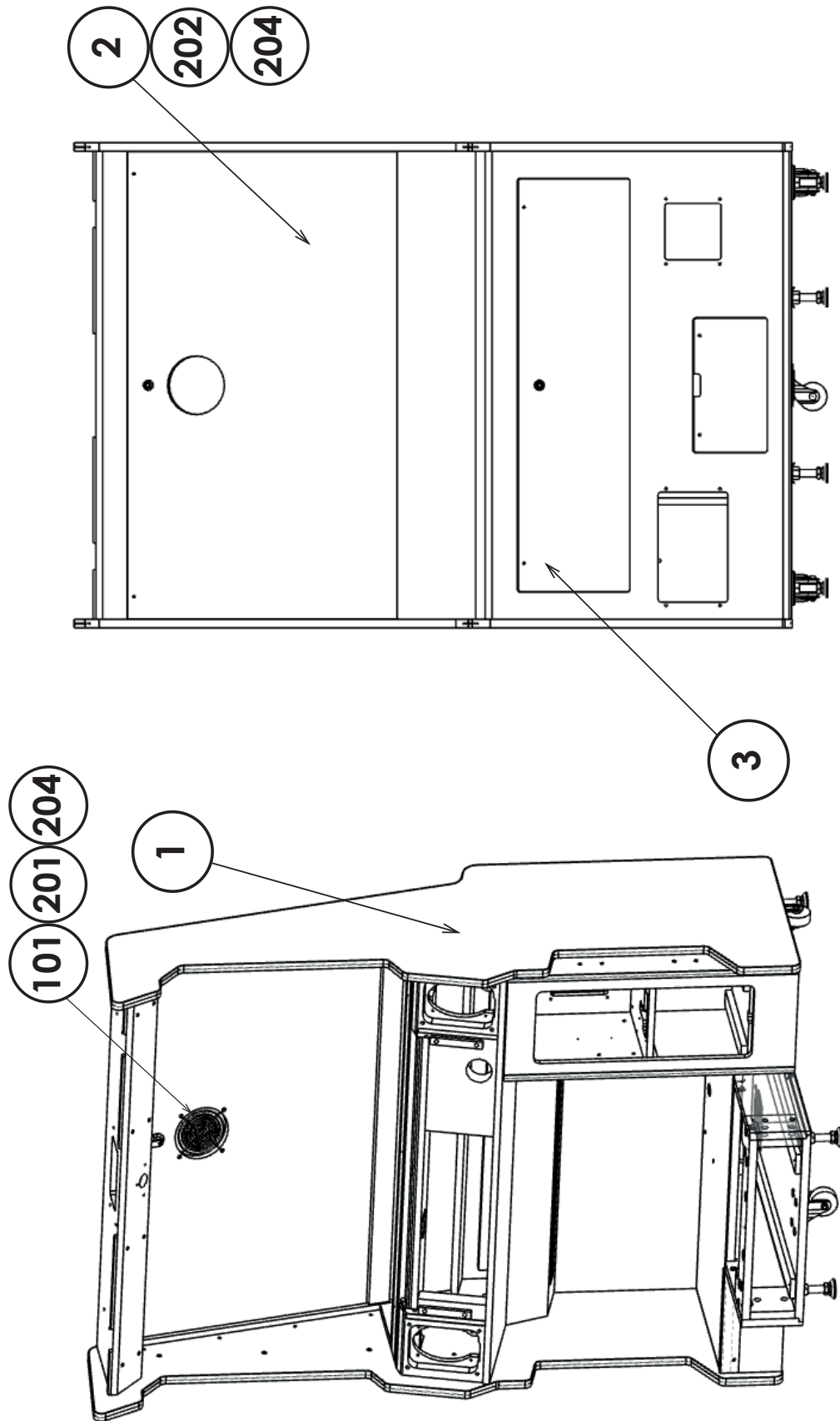

④ ASSY SUB MONITOR CABI (DA-7050XUK)

(D-2/2)

| ITEM NO | PART NO | DESCRIPTION | REFERENCE | QTY |
|---------|-------------|-------------------------------|-----------|-----|
| ***1 | DA-7051UK | MONITOR CABINET | | 1 |
| ****2 | DA-7051-BUK | DOOR UPPER BACK | | 1 |
| ****3 | DA-7051-CUK | DOOR LOWER BACK | | 1 |
| ***2 | DA-7001UK | SASH FRONT STEP | | 1 |
| ***101 | FN1012 | FAN GUARD METAL 120MM (FG-12) | | 2 |
| ***201 | 029-B00412 | M4X12 SKT BH PAS | | 8 |
| ***202 | 029-B00425 | M4X25 SKT BH PAS | | 8 |
| ***204 | 068-441616 | M4 WSHR 16OD FLT PAS | | 10 |

⑤ ASSY LH INNER PANEL (DA-7060XUK)

(D-1/1)

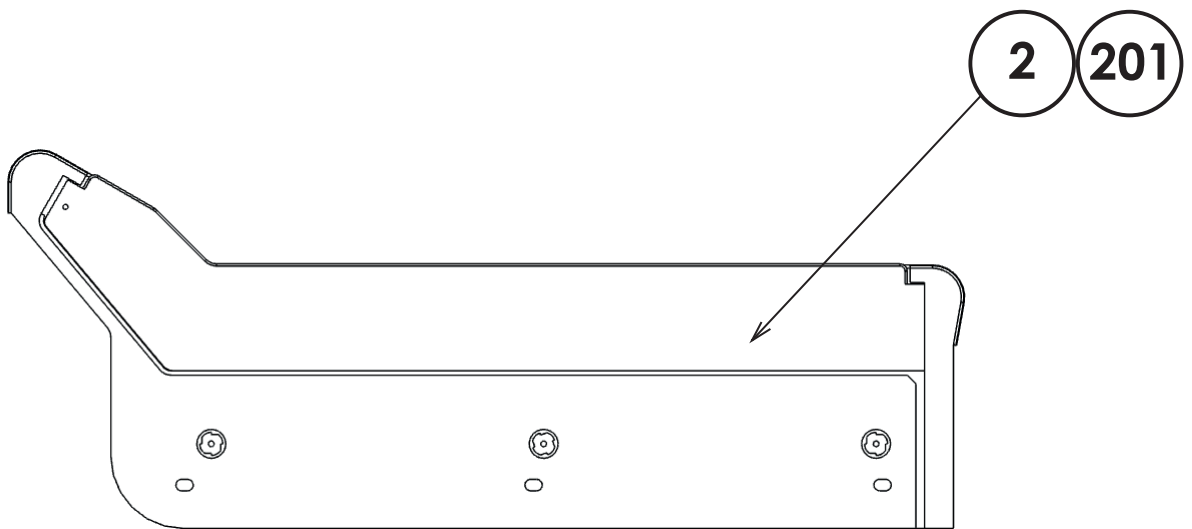
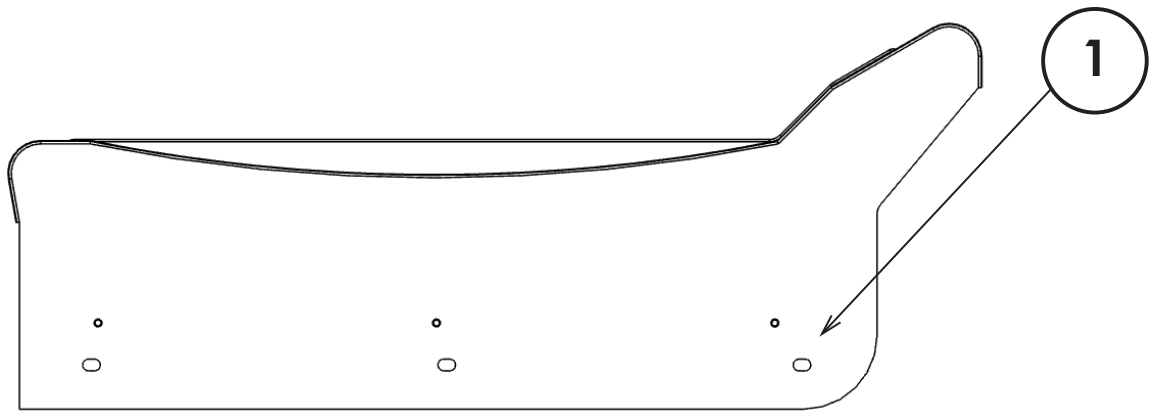

| ITEM NO | PART NO | DESCRIPTION | REFERENCE | QTY |
|---------|------------------|---------------------------|-----------|-----|
| ***1 | DA-7061UK | PANEL INNER LH | | 1 |
| ***2 | DA-7063UK | PANEL INNER CHEEK ACRYLIC | | 1 |
| ***101 | 390-2012-080-RGB | LED FLEXIBLE RGB 800MM | | 1 |
| ***201 | 012-P03512-F | N6X1/2" S/TAP FLG PAS | | 1 |
| ***301 | BE-6001UK | ASSY LED CLIP | | 1 |

⑥ ASSY RH INNER PANEL (DA-7065XUK)

(D-1/1)

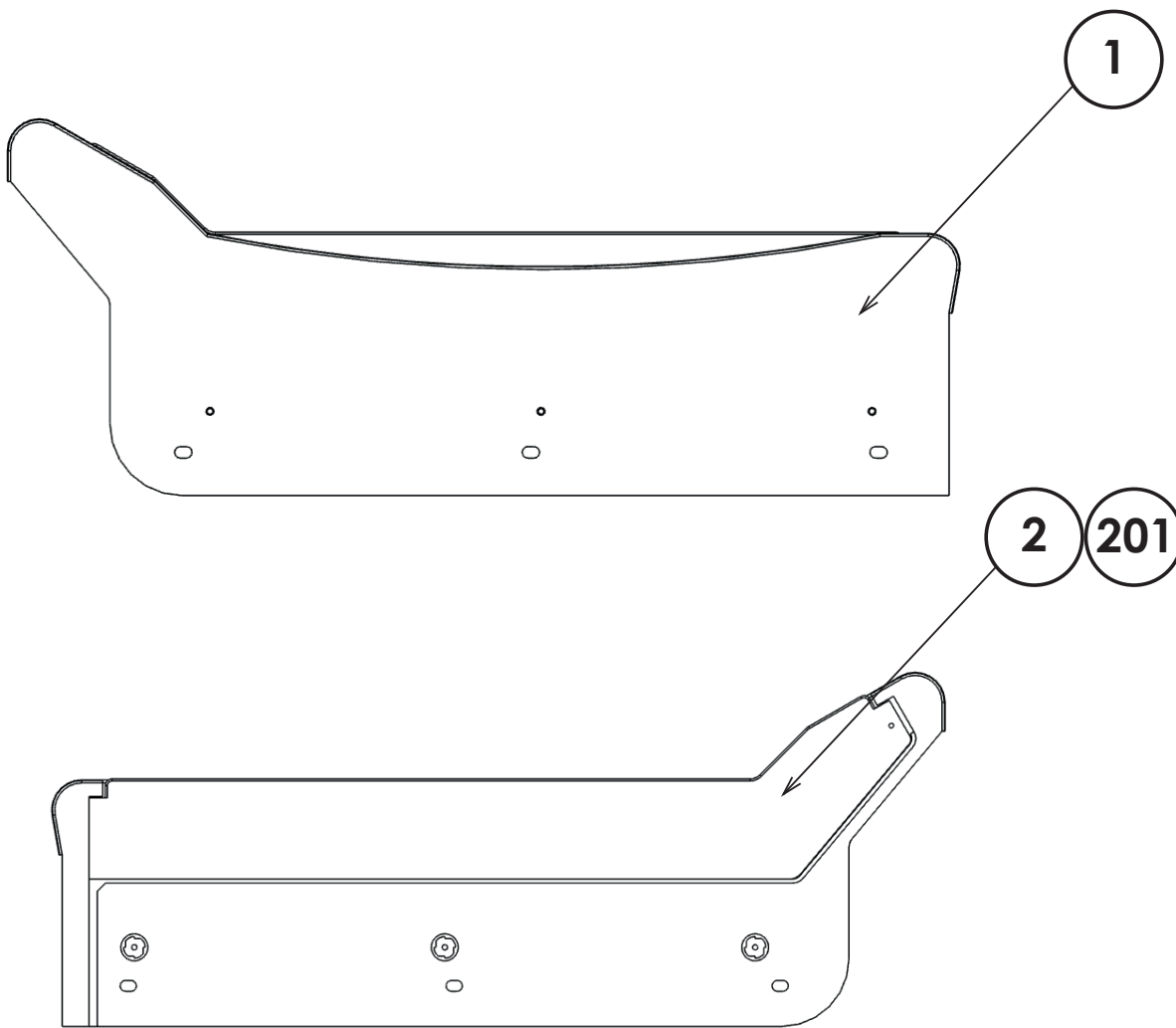

| ITEM NO | PART NO | DESCRIPTION | REFERENCE | QTY |
|---------|------------------|---------------------------|-----------|-----|
| ***1 | DA-7062UK | PANEL INNER RH | | 1 |
| ***2 | DA-7063UK | PANEL INNER CHEEK ACRYLIC | | 1 |
| ***101 | 390-2012-080-RGB | LED FLEXIBLE RGB 800MM | | 1 |
| ***201 | 012-P03512-F | N6X1/2" S/TAP FLG PAS | | 1 |
| ***301 | BE-6001UK | ASSY LED CLIP | | 1 |

⑦ ASSY AC UNIT (DA-7080UK)

(D-1/1)

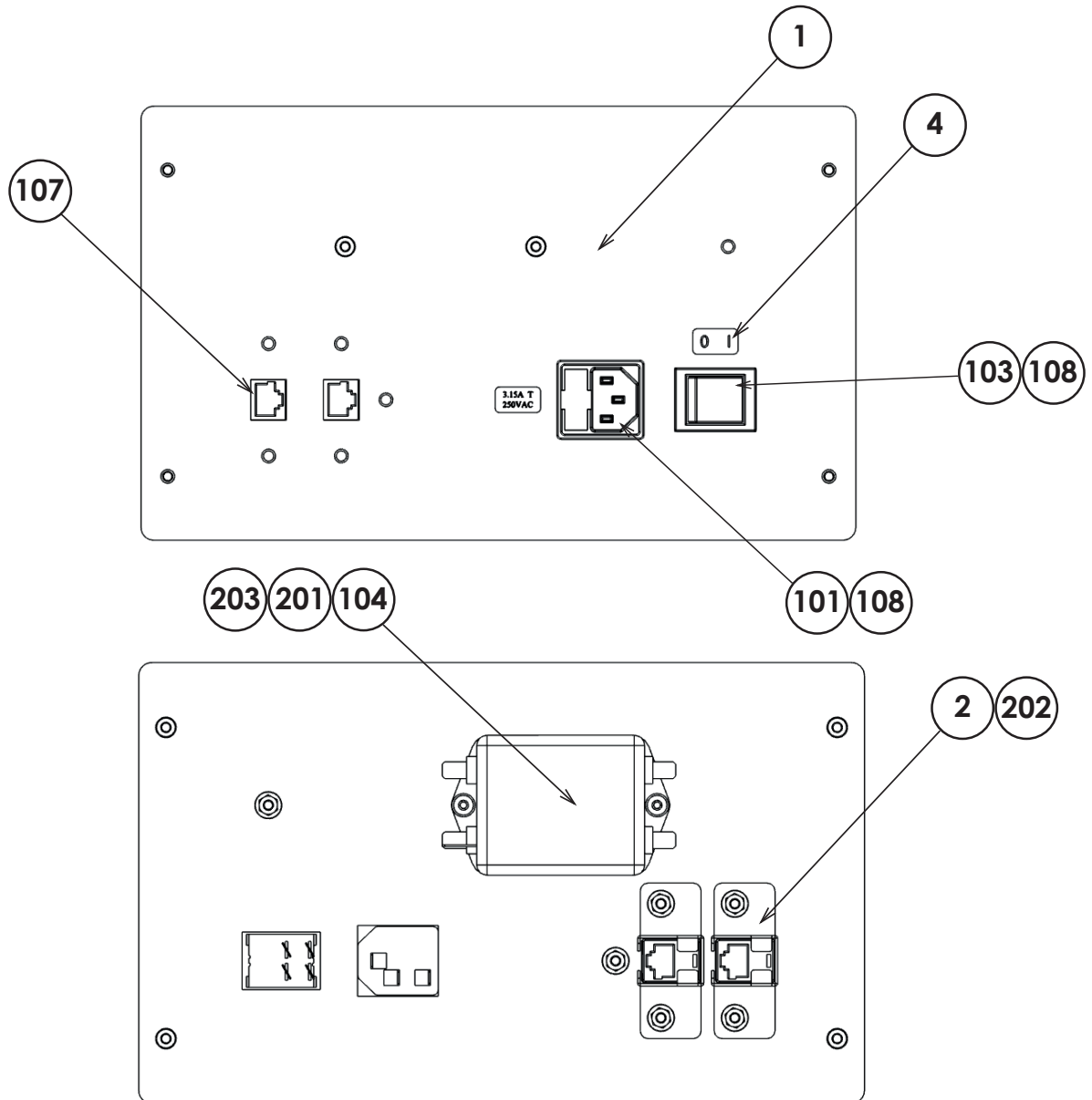

| ITEM NO | PART NO | DESCRIPTION | REFERENCE | QTY |
|---------|-----------------|----------------------------------|-----------|-----|
| ***1 | DA-1081UK | PLATE AC | | 1 |
| ***2 | TFF-0402UK | CONN COVER | | 1 |
| ***3 | LB1096 | STICKER PROTECTIVE EARTH | | 1 |
| ***4 | LB1131 | LABEL ON / OFF | | 1 |
| ***5 | ST-0403UK | PLATE AC CAP | | 1 |
| ***101 | EP1302 | EUROSOCKET FUSED 10A 250VAC | | 1 |
| ***102 | 514-5078-3150 | FUSE 3.15 X 20 CERAMIC SB 3150mA | | 2 |
| ***103 | SW1109 | SWITCH ROCKER 250V AC | | 1 |
| ***104 | EP1419 | FILTER SCHAFFNER 2030-16-06 | | 1 |
| ***107 | EP1391 | COUPLER INLINE LAN RJ45 | | 1 |
| ***108 | 310-5029-D508 | HEAT SHRINK SLEEVING 50.8DIA | | 8cm |
| ***109 | LB1126-3150-250 | FUSE LABEL 3.15A 250V | | 1 |
| ***201 | 029-B00408 | M4X8 SKT BH PAS | | 2 |
| ***202 | 050-F00400 | M4 NUT FLG SER PAS | | 6 |
| ***203 | 060-S00400 | M4 WSHR SPR PAS | | 2 |
| ***301 | DA-60101UK | WH AC IN | | 1 |

⑧ ASSY CONTROL PANEL (DA-7200XUK)

(D-1/3)

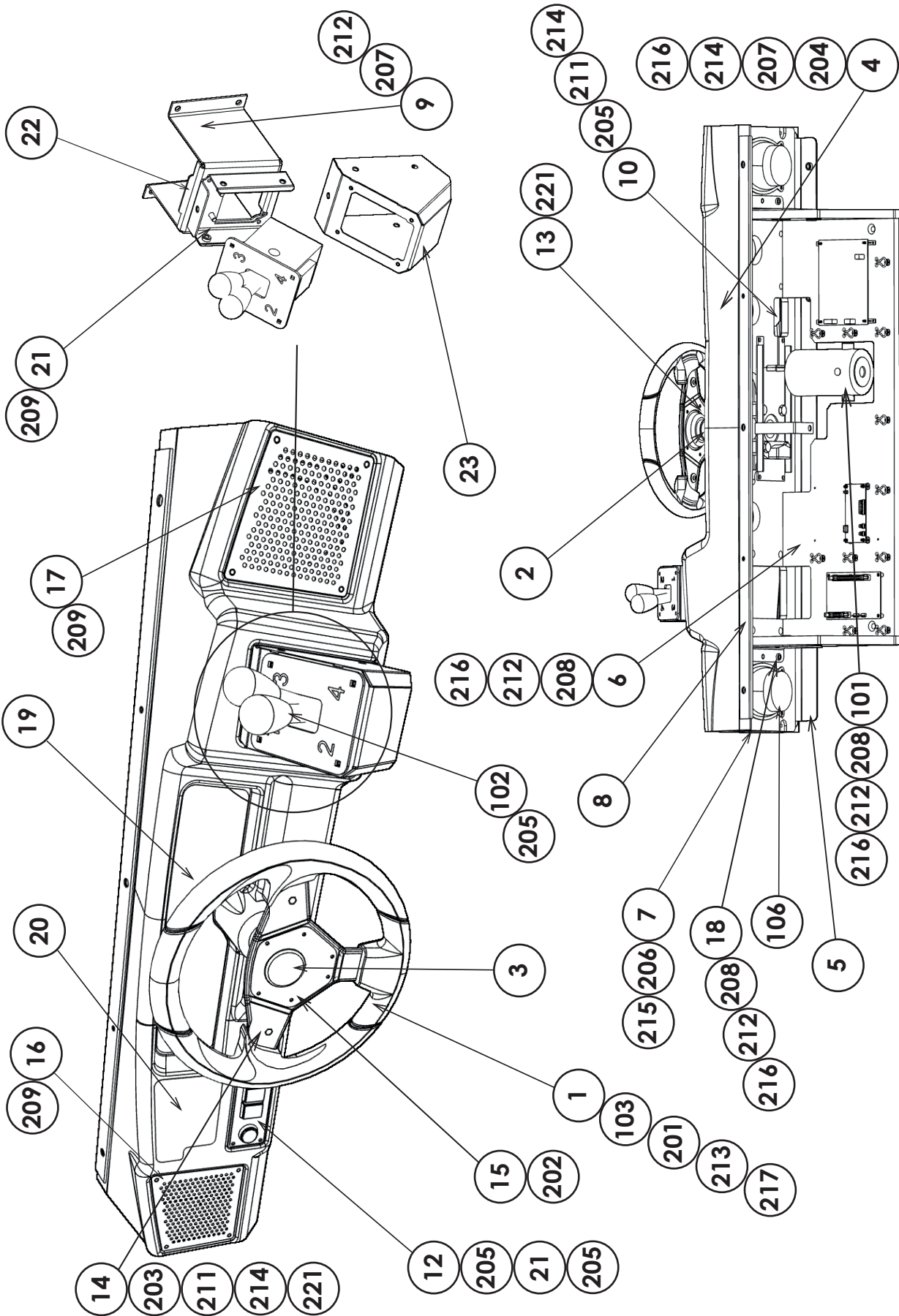

8 ASSY CONTROL PANEL (DA-7200XUK)

(D-2/3)

| ITEM NO | PART NO | DESCRIPTION | REFERENCE | QTY |
|---------|---------------|------------------------------------|-----------|-----|
| ***1 | RNE-2001 | STEERING WHEEL | | 1 |
| ***2 | RD-2009UK | HANDLE COLLAR | | 1 |
| ***3 | DA-2022-BUK | STEERING EMBLEM | | 1 |
| ***4 | DA-2001-01XUK | CONTROL PANEL COVER | | 1 |
| ***5 | DA-7212UK | CTRL PNL SUPP BRKT | | 1 |
| ***6 | DA-7213UK | BASE CTRL PNL | | 1 |
| ***7 | DA-7214UK | BRKT CTRL PNL COVER | | 2 |
| ***8 | DA-7216UK | BRKT CTRL PNL RETAINING | | 1 |
| ***9 | DA-2004UK | SHIFT BRACKET | | 1 |
| ***10 | DA-2006UK | BRKT CONTROL BUTTON | | 1 |
| ***12 | DA-2100UK | ASSY SW PLATE | | 1 |
| ***13 | RND-0222 | PLATE REAR RNE HOOP | | 1 |
| ***14 | RND-0223 | PLATE FRONT RNE HOOP | | 1 |
| ***15 | RND-0224 | PLATE FRONT UPPER CAP RNE HOOP | | 1 |
| ***16 | DA-2007UK | SPEAKER GRILLE L | | 1 |
| ***17 | DA-2008UK | SPEAKER GRILLE R | | 1 |
| ***18 | DA-2016UK | BRKT BASE SUPPORT | | 2 |
| ***19 | DA-7207UK | STICKER DIALS | | 1 |
| ***20 | DA-7208UK | STICKER SUB INSTR | | 1 |
| ***21 | DA-2301UK | BASE SUPPORT SHIFTER | | 1 |
| ***22 | DA-2302UK | BRKT CLAMP BASE | | 1 |
| ***23 | DA-2303UK | ENCLOSURE SHIFTER MOUNTING | | 1 |
| ***101 | RD-2500UK | MECHA 50-0102-07PT W/SEGA SHAFT | | 1 |
| ***102 | 610-2101-01 | SHIFTER 4 SPEED | | 1 |
| ***103 | OS1254 | EDGING C PROFILE PVC TRIM | | 0.5 |
| ***104 | 280-A01264-WX | ROUTER TWIST D12 SO6.4 WOOD X | | 13 |
| ***106 | 130-04030-E | SPKR ELIP 4OHM 30W VIS DX4x6P | | 2 |
| ***107 | FR-838-001UK | MOTOR CONT HAPP 50-2000-03 | | 1 |
| ***108 | 838-0005UK | I/O BOARD SAE | | 1 |
| ***109 | OS1011 | PCB FEET RICHCO LCBS-L-5-01 | | 4 |
| ***111 | 838-0026UK | AMP 2.1 40W KEENE | | 3 |
| ***112 | 838-0041UK | PCBA WOOLLY 2 | | 1 |
| ***113 | 280-L00640-WX | STANDOFF 6MM WOOD XL | | 4 |
| ***201 | 020-000820 | M8X20 BLT PAS | | 1 |
| ***202 | 020-B00308-0B | M3X8 SKT BH BLK | | 6 |
| ***203 | 029-B00408 | M4X8 SKT BH PAS | | 3 |
| ***204 | 029-B00412 | M4X12 SKT BH PAS | | 2 |
| ***205 | 029-B00412-0B | M4X12 SKT BH BLK | | 16 |
| ***206 | 029-B00430 | M4X25 SKT BH PAS | | 4 |
| ***207 | 029-B006012 | M6X12 SKT BH PAS | | 8 |
| ***208 | 029-B00630-0B | M6X30 SKT BH BLK | | 14 |
| ***209 | 060-F00400-0B | M4 WSHR FORM A FLT BLK | | 12 |
| ***210 | 060-F01600 | M16 WSHR FORM A FLT PAS | | 2 |
| ***211 | 060-S00400 | M4 WSHR SPR PAS | | 7 |
| ***212 | 060-S00600 | M6 WSHR SPR PAS | | 18 |
| ***213 | 060-S00800 | M8 WSHR SPR PAS | | 1 |
| ***214 | 068-441616 | M4 WSHR 16OD FLT PAS | | 9 |
| ***215 | 068-441616-0B | M4 WSHR 16OD FLT BLK | | 4 |
| ***216 | 068-652016 | M6 WSHR 20OD FLT PAS | | 18 |
| ***217 | 068-852515-0B | M8 WSHR 25OD FLT BNP | | 3 |

⑧ ASSY CONTROL PANEL (DA-7200XUK)

(D-3/3)

| | | | |
|--------|----------------|--------------------------|---|
| ***218 | 012-P00325 | N4X1" S/TAP PAN PAS | 4 |
| ***219 | 012-P03506-F | N6X1/4" S/TAP FLG PAS | 4 |
| ***220 | 012-P03512-F | N6X1/2" S/TAP FLG PAS | 8 |
| ***221 | 050-U00400 | M4 NUT NYLOK PAS | 8 |
| ***301 | DA-60123UK | WH BUTTON PLATE | 1 |
| ***302 | DA-60106UK | WH I/O | 1 |
| ***303 | DA-60109UK | WH DC MOTOR CONTROL | 1 |
| ***304 | 600-7141-100UK | CABLE JVS TYPE A-B 100CM | 1 |

⑨ ASSY 43 LCD AUO MONITOR (DA-7270UK)

(D-1/1)

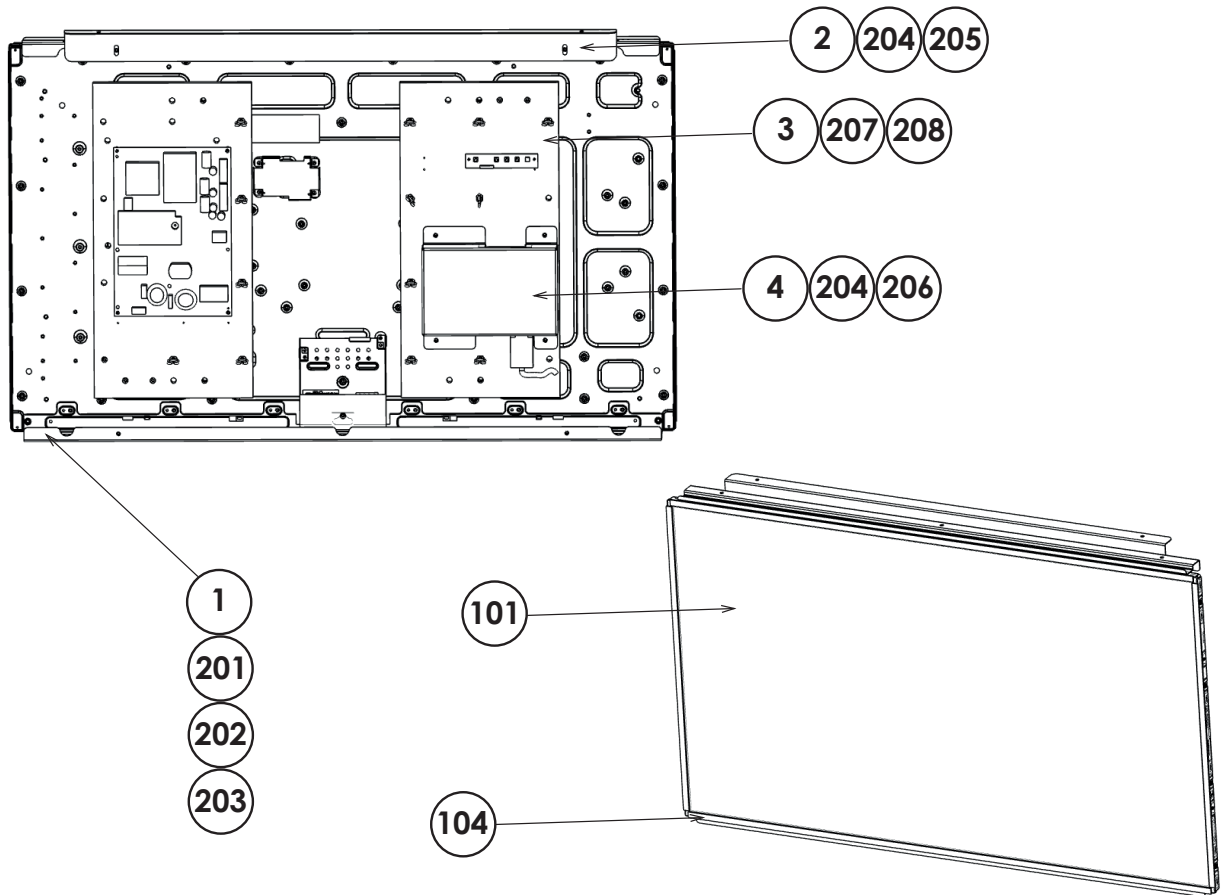

| ITEM NO | PART NO | DESCRIPTION | REFERENCE | QTY |
|---------|---------------|--------------------------------|-----------|-----|
| ***1 | DA-7261UK | BRKT SCREEN SUPPORT BASE | | 2 |
| ***2 | DA-1272UK | BRKT LCD SUPPORT TOP | | 1 |
| ***3 | TRF-1210UK | PNL PRISMA BD DMODUL MNT 55 | | 2 |
| ***4 | TRF-1207UK | COVER PRISMA BD DMODUL | | 1 |
| ***5 | DSD-5109UK | BRKT LED FILTER | | 1 |
| ***101 | 200-6043-AUO | 43" LCD AUO P430HVN01.1 | | 1 |
| ***102 | OS1247 | ALUMINIUM STICKY CLIP ASK-3 | | 2 |
| ***103 | 280-A01264-WX | ROUTER TWIST D12 SO6.4 WOOD XL | | 13 |
| ***104 | OS1230 | FOAM STRIP 2mm X 10mm | | 3.3 |
| ***105 | 280-L00811-OS | STANDOFF 7.94OD 3.56ID 11.11L | | 10 |
| ***106 | EP1419 | FILTER SCHAFFNER FN2030-16-06 | | 1 |
| ***107 | 440-WS0002UK | LABEL WARNING HI VOLT | | 1 |
| ***108 | 440-DS0010UK | LABEL DANGER HI VOLT | | 2 |
| ***201 | 029-B00305 | M3X5 SKT BH PAS | | 8 |
| ***202 | 060-S00300-0B | M3 WSHR SPR BLK | | 8 |
| ***203 | 060-F00300-0B | M3 WSHR FORM A FLT BLK | | 8 |
| ***204 | 029-B00412 | M4X12 SKT BH PAS | | 8 |
| ***205 | 060-S00400 | M4 WSHR SPR PAS | | 2 |
| ***206 | 068-441616 | M4 WSHR 16OD FLT PAS | | 8 |
| ***207 | 029-B00620 | M6X20 SKT BH PAS | | 4 |
| ***208 | 068-652016 | M6 WSHR 20OD FLT PAS | | 4 |
| ***209 | 012-P00320 | N4X3/4" S/TAP PAN PAS | | 10 |

⑩ ASSY MAIN BOARD (DA-7500UK)

(D-1/1)

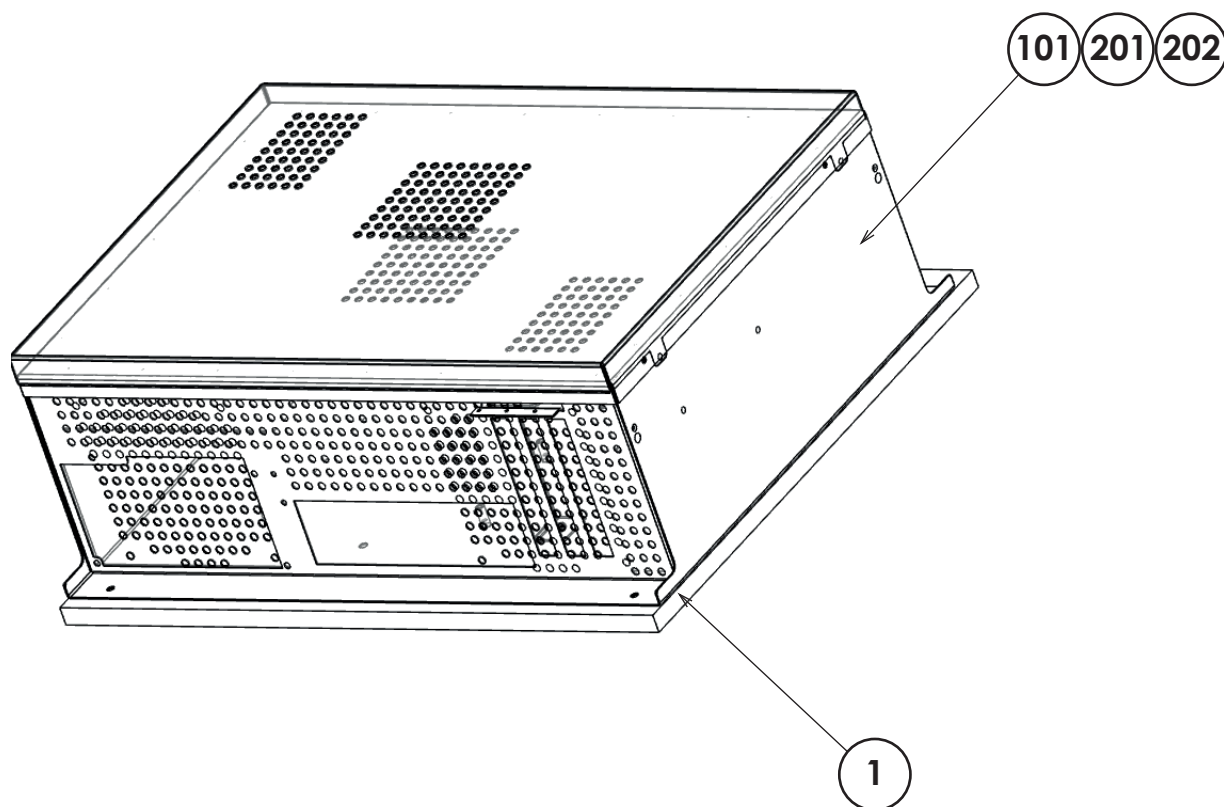

| ITEM NO | PART NO | DESCRIPTION | REFERENCE | QTY |
|---------|-----------------|-------------------------|-----------|-----|
| ***1 | DA-7501UK | WOODEN BASE MAIN BD | | 1 |
| ***101 | 610-0012-02UK | ASSY MAIN BOARD | | 1 |
| ***103 | LB1101 | STICKER WARNING BATTERY | | 1 |
| ***104 | LB1111 | STICKER PLEASE RECYCLE | | 1 |
| ***201 | 029-B00412 | M4X12 SKT BH PAS | | 4 |
| ***202 | 068-441616 | M4 WSHR 16OD FLT PAS | | 4 |
| ***301 | DA-60103UK | WH AC GAMEBOARD | | 1 |
| ***302 | DA-60107UK | WH AUDIO A | | 1 |
| ***303 | DA-60113UK | WH PARALLEL | | 1 |
| ***304 | 600-7011-0200UK | DA DVI TO DVI 200CM | | 1 |
| ***306 | 600-7269-0200UK | LAN CABLE 200CM | | 1 |

11 ASSY ELEC BOARD (DA-7600UK)

(D-1/1)

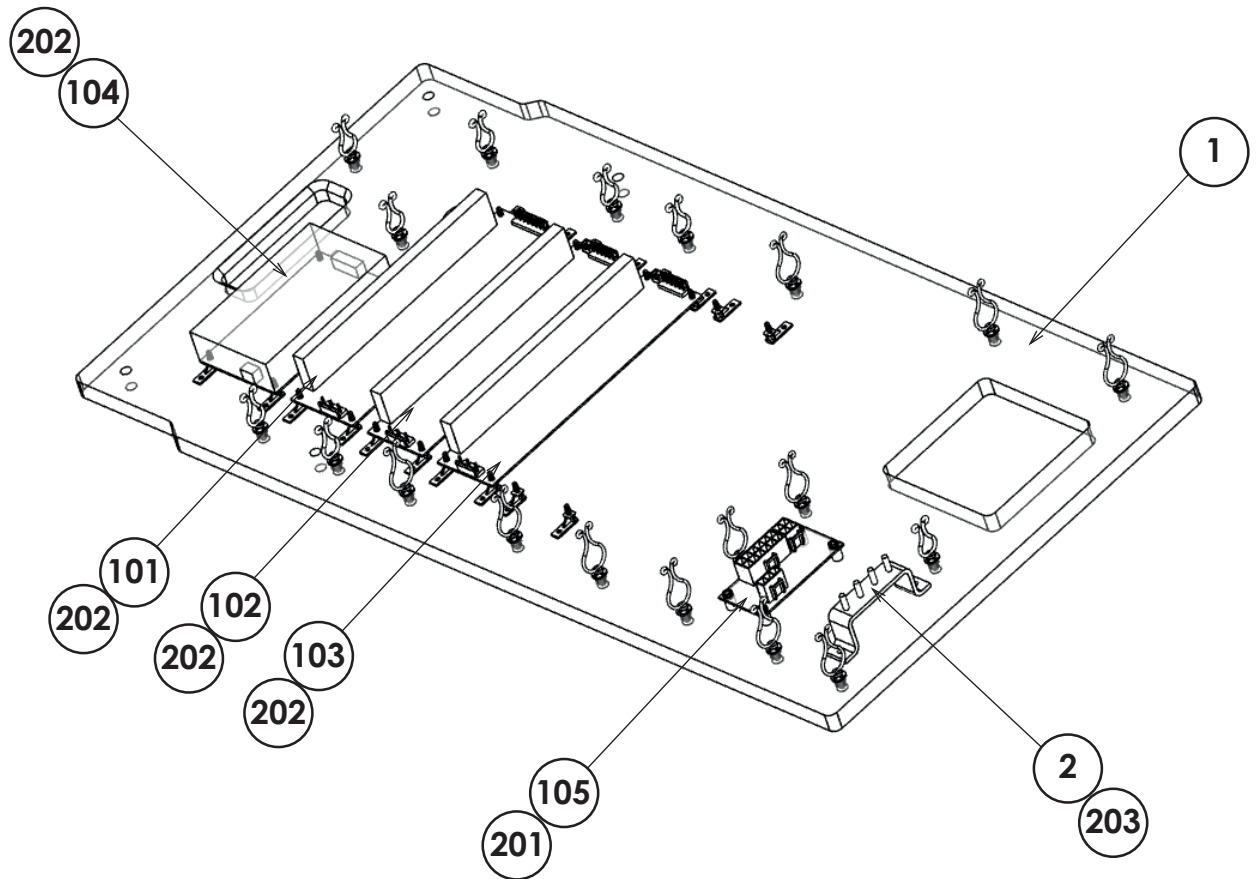

| ITEM NO | PART NO | DESCRIPTION | REFERENCE | QTY |
|---------|-----------------|--------------------------------|-----------|-----|
| ***1 | DA-7601UK | WOODEN BASE ELEC BD | | 1 |
| ***2 | CFB-4003-01UK | EARTH PLATE | | 1 |
| ***101 | 400-100-012-01 | PSU 12V 100W MW LPS-100-012-01 | | 1 |
| ***102 | 400-075-024-01 | PSU 24VDC 75W MW LPS-75-24 | | 1 |
| ***103 | 400-075-012-01 | PSU 5VDC 75W MW LPS-75-12 | | 1 |
| ***104 | 400-065-0512-01 | PSU 5V-12V DC 65W MW RPD-65C | | 1 |
| ***105 | 838-14551-02UK | AC DISTRIBUTION BD | | 1 |
| ***106 | OS1011 | PCB FEET RICHSO LCBS-L-5-01 | | 20 |
| ***107 | 280-A01264-WX | ROUTER TWIST D12 SO6.4 WOOD X | | 8 |
| ***108 | 280-A02064-WX | ROUTER TWIST D20 SO6.4 WOOD X | | 11 |
| ***109 | 440-DS0010UK | LABEL DANGER HI VOLT | | 2 |
| ***110 | 400-100-005-01 | PSU 5V 100W MW LPS-100-05 | | 1 |
| ***201 | 012-P00325 | N4X1" S/TAP PAN PAS | | 4 |
| ***202 | 012-P03506-F | N6X1/4" S/TAP FLG PAS | | 20 |
| ***203 | 012-P03512-F | N6X1/2" S/TAP FLG PAS | | 2 |
| ***204 | 050-F00400 | M4 NUT FLG SER PAS | | 4 |
| ***301 | DA-60102UK | WH AC DIST | | 1 |
| ***302 | DA-60105UK | WH DC DIST | | 1 |
| ***303 | DA-60111UK | WH BASE TO SEAT | | 1 |

⑫ ASSY FAN (SND-1340UK)

(D-1/1)

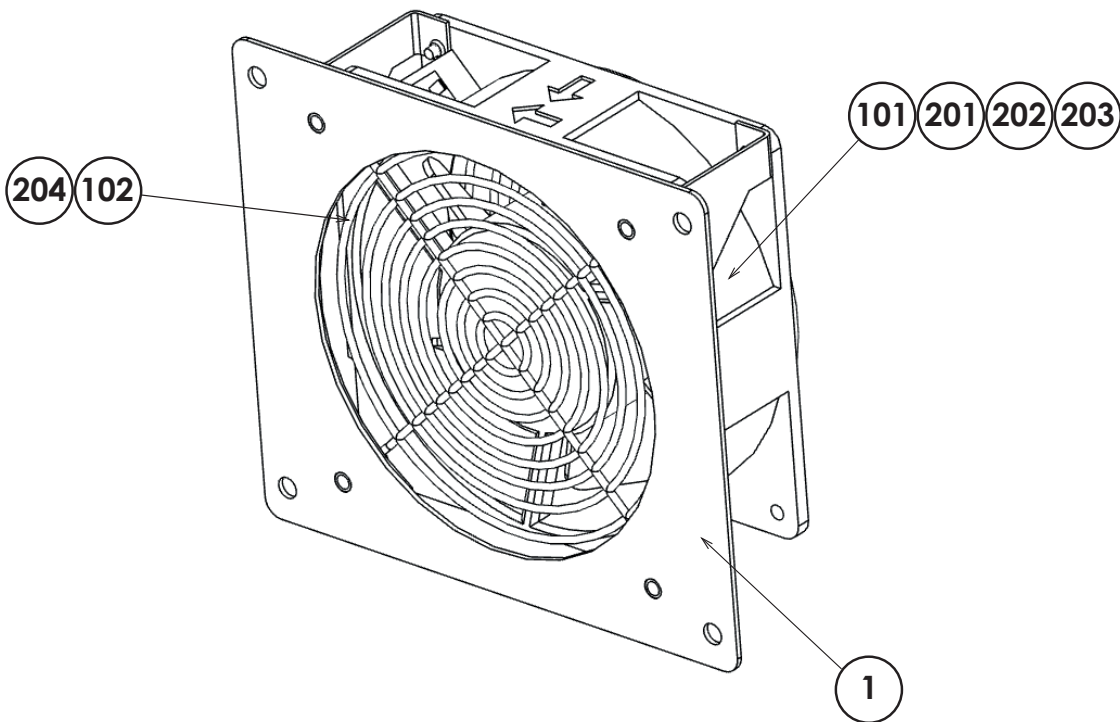

| ITEM NO | PART NO | DESCRIPTION | REFERENCE | QTY |
|---------|---------------|-------------------------------|-----------|-----|
| ***1 | SND-1341UK | BRKT FAN MTG | | 1 |
| ***101 | 260-0012-01UK | FAN DC 12V AXIAL | | 1 |
| ***102 | FN1012 | FAN GUARD METAL 120MM (FG-12) | | 2 |
| ***201 | 020-B00316-0B | M3X16 SKT BH BLK | | 4 |
| ***202 | 060-S00300-0B | M3 WSHR SPR BLK | | 4 |
| ***203 | 060-F00300-0B | M3 WSHR FORM A FLT BLK | | 4 |
| ***204 | 050-U00400 | M4 NUT NYLOK PAS | | 4 |
| ***301 | DB-60030UK | WH LED WHT | | 1 |

⑬ ASSY CAMERA MODULE (DA-1350UK)

(D-1/1)

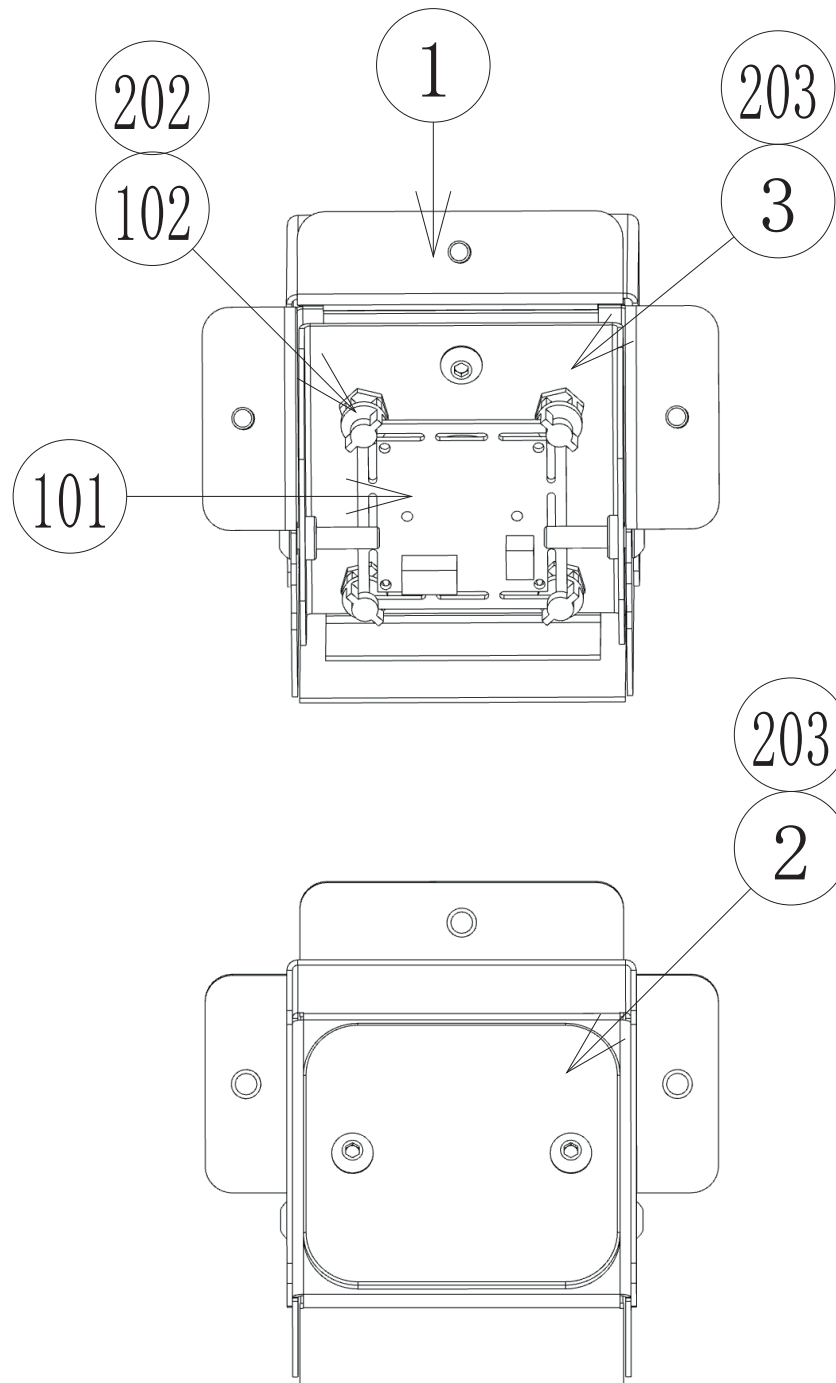

| ITEM NO | PART NO | DESCRIPTION | REFERENCE | QTY |
|---------|---------------|--|-------------|-----|
| ****1 | DA-1351UK | BRKT SURROUND | | 1 |
| ****2 | DA-1352UK | COVER CAMERA | | 1 |
| ****3 | DA-1353UK | PLATE MTG CAMERA | | 1 |
| ****101 | EP1483 | CAMERA USB130W01MT | | 1 |
| ****102 | 280-0005UK | HOLDER EDGE PCB SCREW MNT (101)-4 6MM | | 4 |
| ****201 | | | (101)-4 | 4 |
| ****202 | 012-P03506-F | N6X1/4" S/TAP FLG PAS | (102)-4 | 4 |
| ****203 | 029-B00412-0B | M4X12 SKT BH BLK | (2)-2,(3)-3 | 5 |

14 ASSY ADJUSTABLE SEAT SC (DA-7700UK)

(D-2/2)

18

PARTS LIST

| ITEM NO | PART NO | DESCRIPTION | REFERENCE | QTY |
|---------|-----------------|--------------------------------|-----------|-----|
| ***2 | DA-7702UK | SEAT BASE CABINET | | 1 |
| ***3 | DA-7703UK | SEAT BASE SC | | 1 |
| ***4 | DA-7704UK | TRAY COVER REAR | | 1 |
| ***5 | DA-7705UK | COVER FLOOR LED REAR | | 1 |
| ***6 | DA-7706UK | SEAT MOUNT TRAY SC | | 1 |
| ***7 | DA-7707UK | BRKT SEAT BASE CABI UPPER | | 1 |
| ***9 | DA-7711UK | TRAY COVER FRONT | | 1 |
| ***10 | DA-7721UK | DISC SEAT REAR LED MOUNT | | 1 |
| ***11 | DA-7722UK | DISC SEAT REAR | | 1 |
| ***12 | DA-7723UK | PLATE SEAT REAR DISC | | 2 |
| ***13 | DA-7724UK | STICKER SEAT CAB UPPER | | 1 |
| ***14 | DA-7725UK | STICKER SEAT CAB LH | | 1 |
| ***15 | DA-7726UK | STICKER SEAT CAB RH | | 1 |
| ***16 | DA-7727UK | STICKER SEAT CAB REAR | | 1 |
| ***17 | DA-7728UK | STICKER SEAT UPPER | | 1 |
| ***18 | DA-7729UK | STICKER SEAT LOWER | | 1 |
| ***19 | DA-3405UK | PROTECT RUBBER | | 2 |
| ***20 | DA-3407UK | RUBBER HOLDER L | | 1 |
| ***21 | DA-3408UK | RUBBER HOLDER R | | 1 |
| ***22 | DA-7709UK | BRKT JOINT | | 1 |
| ***23 | DA-7730UK | ASSY SEAT LH OUTER PANEL | | 1 |
| ***24 | DA-7740UK | ASSY SEAT RH OUTER PANEL | | 1 |
| ***101 | 601-0006UK | SEAT SLIDE COBRA SEATS SUBFR07 | | 1 |
| ***102 | OS1198 | P CLIP 11MM | | 3 |
| ***103 | PD-1601-A | SEAT | | 1 |
| ***104 | 601-0460 | CABLE TIE 100MM | | 6 |
| ***106 | 390-2012-040RGB | LED FLEXIBLE RGB 400MM | | 1 |
| ***201 | 012-P03512-FB | N6x1/2" S/TAP FLG BLK | | 30 |
| ***202 | 020-F00650-0B | M6X50 MSCR SKT CSK BLK | | 3 |
| ***203 | 029-B00412 | M4X12 SKT BH PAS | | 4 |
| ***204 | 029-B00425-0B | M4X25 SKT BH BLK | | 6 |
| ***205 | 029-B00612-0B | M6X12 SKT BH BLK | | 5 |
| ***206 | 029-B00816-0B | M8X16 SKT BH BLK | | 8 |
| ***207 | 029-B00830-0B | M8X30 SKT BH BLK | | 15 |
| ***208 | 050-U00800 | M8 NUT NYLOK PAS | | 2 |
| ***209 | 060-F01200 | M12 WSHR FORM A FLT | | 2 |
| ***210 | 060-S00800-0B | M8 WSHR SPR BLK | | 20 |
| ***211 | 068-441616 | M4 WSHR 16OD FLT PAS | | 4 |
| ***212 | 068-441616-0B | M4 WSHR 16OD FLT BLK | | 6 |
| ***213 | 068-652016-0B | M6 WSHR 20OD FLT BLK | | 13 |
| ***214 | 068-852216-0B | M8 WSHR 22OD FLT BLK | | 19 |
| ***215 | 050-F00600 | M6 NUT FLG SER PAS | | 8 |
| ***301 | DA-60112UK | WH SEAT BASE | | 1 |
| ***302 | DA-60114UK | WH SEAT UPPER | | 1 |
| ***303 | DA-6007UK | ASSY SEAT LIGHTING | | 1 |
| ****1 | 390-2012-010RGB | LED FLEXIBLE RGB 100MM | | 1 |
| ****2 | DA-60122UK | WH SEAT LIGHTING | | 1 |
| ***304 | BE-6001UK | ASSY LED CLIP | | 3 |
| ***307 | DA-60122UK | WH SEAT LIGHTING | | 1 |
| ***308 | DA-60124UK | WH SERIAL LED SPLITTER | | 1 |

15 ASSY SEAT LH OUTER PANEL (DA-7730UK)

(D-1/1)

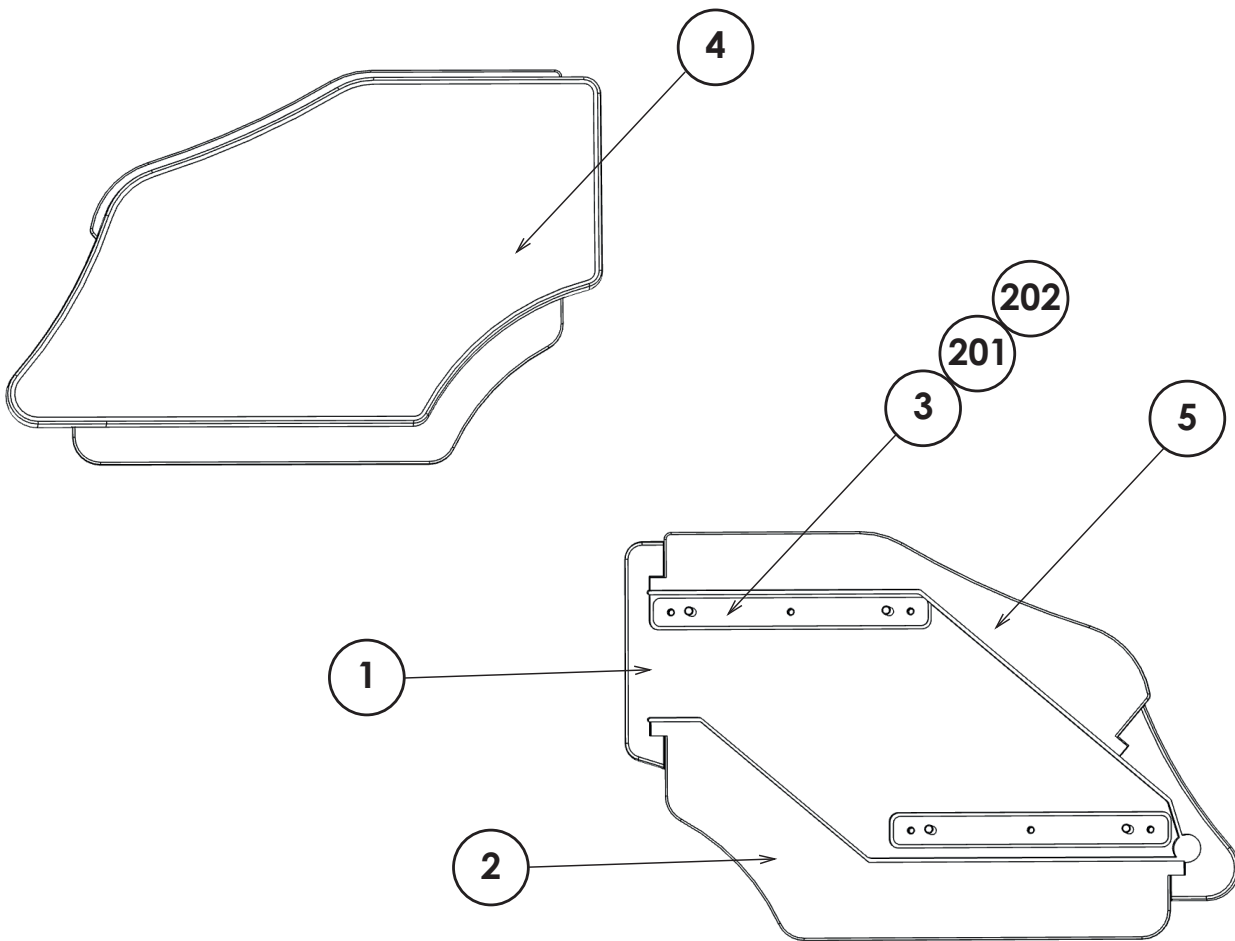

| ITEM NO | PART NO | DESCRIPTION | REFERENCE | QTY |
|---------|----------------|------------------------------|-----------|------|
| ***1 | DA-7731UK | PANEL SEAT LH OUTER | | 1 |
| ***2 | DA-7732UK | PANEL SEAT OUTER ACRYLIC | | 1 |
| ***3 | DA-7733UK | PLATE STUD | | 2 |
| ***4 | DA-7734UK | STICKER SEAT LH OUTER | | 1 |
| ***5 | DA-7736UK | PANEL SEAT OUTER TOP ACRYLIC | | 1 |
| ***201 | 029-B00412 | M4X12 SKT BH PAS | | 6 |
| ***202 | 068-441616 | M4 WSHR 16OD FLT PAS | | 6 |
| ***301 | DA-6010UK | ASSY SEAT PANEL LIGHTING | | 2 |
| ****1 | 390-2305-10-AD | SLED FLX S602812B 10mm | | 0.04 |
| ****2 | DA-60024UK | WH SERIAL LED | | 1 |

①⑥ ASSY SEAT RH OUTER PANEL (DA-7740UK)

(D-1/1)

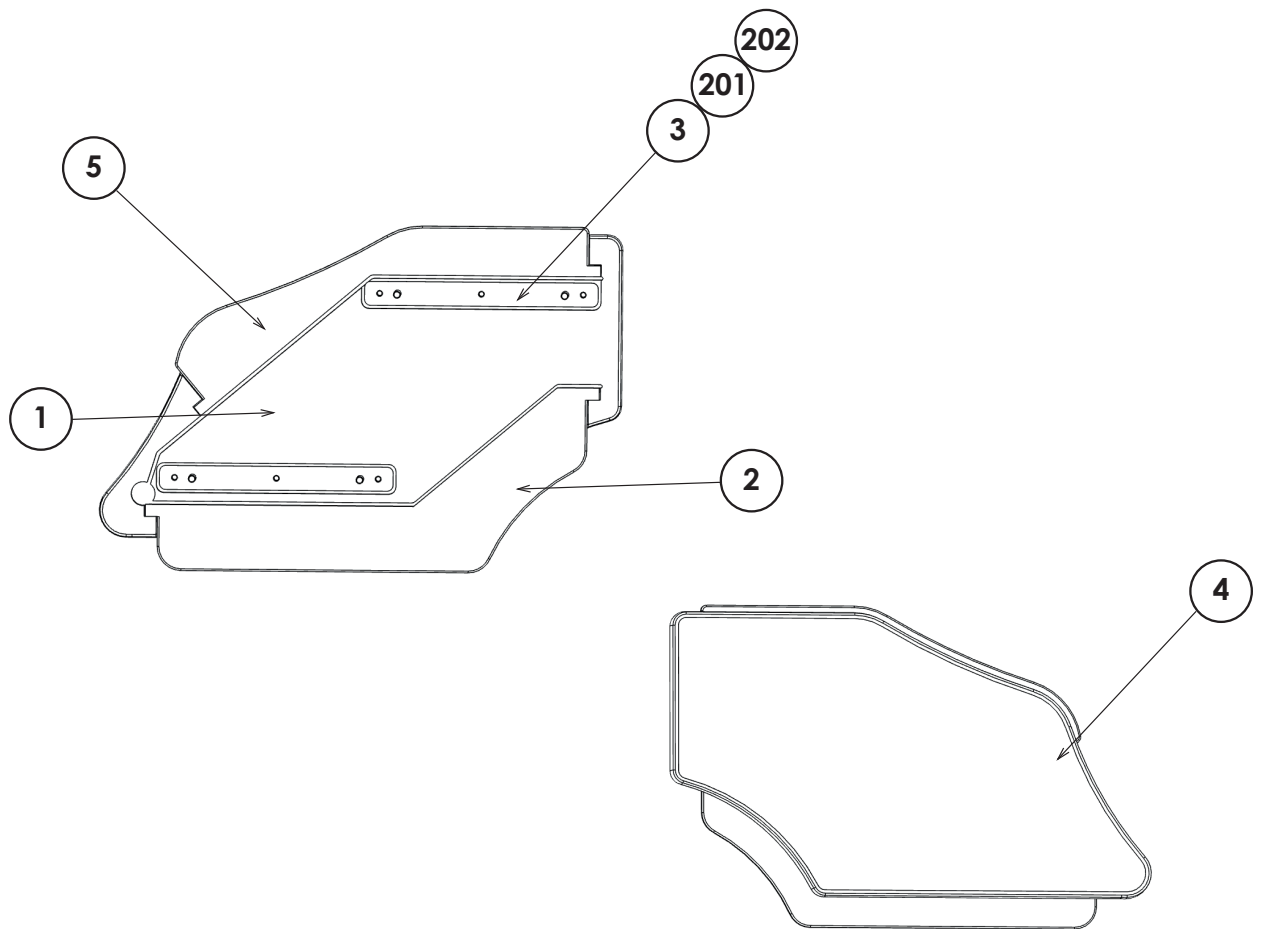

| ITEM NO | PART NO | DESCRIPTION | REFERENCE | QTY |
|---------|----------------|------------------------------|-----------|------|
| ***1 | DA-7741UK | PANEL SEAT RH OUTER | | 1 |
| ***2 | DA-7732UK | PANEL SEAT OUTER ACRYLIC | | 1 |
| ***3 | DA-7733UK | PLATE STUD | | 2 |
| ***4 | DA-7744UK | STICKER SEAT RH OUTER | | 1 |
| ***5 | DA-7736UK | PANEL SEAT OUTER TOP ACRYLIC | | 1 |
| ***201 | 029-B00412 | M4X12 SKT BH PAS | | 6 |
| ***202 | 068-441616 | M4 WSHR 16OD FLT PAS | | 6 |
| ***301 | DA-6010UK | ASSY SEAT PANEL LIGHTING | | 2 |
| ****1 | 390-2305-10-AD | SLED FLX S602812B 10mm | | 0.04 |
| ****2 | DA-60024UK | WH SERIAL LED | | 1 |

17 ASSY INSTALLATION KIT (DA-INST-STREET)

(D-1/1)

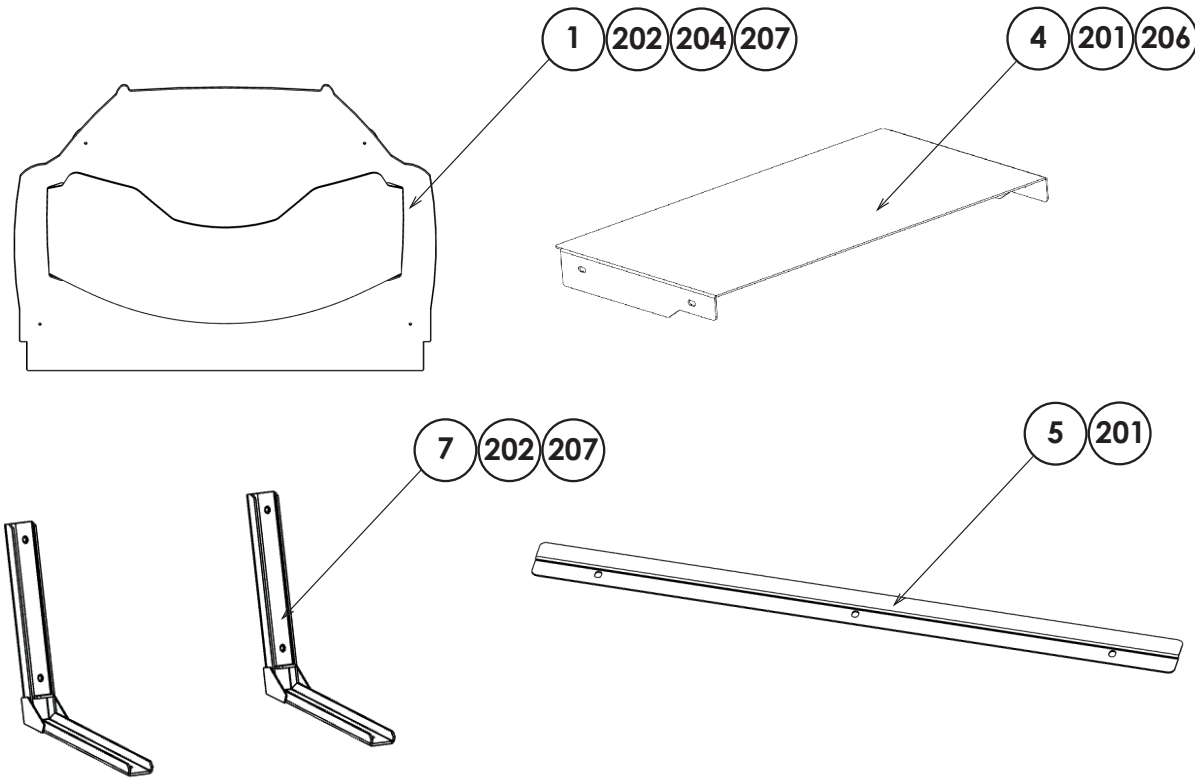

| ITEM NO | PART NO | DESCRIPTION | REFERENCE | QTY |
|---------|------------|--------------------------------|-----------|-----|
| **1 | DA-7800UK | ASSY BILLBOARD | | 1 |
| **4 | DA-7053UK | FOOTWELL LID | | 1 |
| **5 | DA-7054UK | SASH FOOTWELL LID | | 1 |
| **6 | DA-7805UK | COVER CAMERA ACCESS | | 1 |
| **7 | DA-7011UK | MOUNT BILLBOARD CABI | | 2 |
| **101 | LM1227 | UK MAINS LEAD 10A WITH PLUG | | 1 |
| **102 | LM1246 | EUROLEAD 10A EUROPEAN SOCKET | | 1 |
| **103 | LMI1500UK | MAINS LEAD USA/IEC H80-1205-00 | | 1 |
| **201 | 029-B00425 | M4X25 SKT BH PAS | | 7 |
| **202 | 029-B00625 | M6X25 SKT BH PAS | | 11 |
| **204 | 060-S00600 | M6 WSHR SPR PAS | | 3 |
| **206 | 068-441616 | M4 WSHR 16OD FLT PAS | | 7 |
| **207 | 068-652016 | M6 WSHR 20OD FLT PAS | | 11 |
| **401 | OS1019 | SELF SEAL BAG 9X12.3/4 | | 1 |

18 ASSY BILLBOARD (DA-7800UK)

(D-1/1)

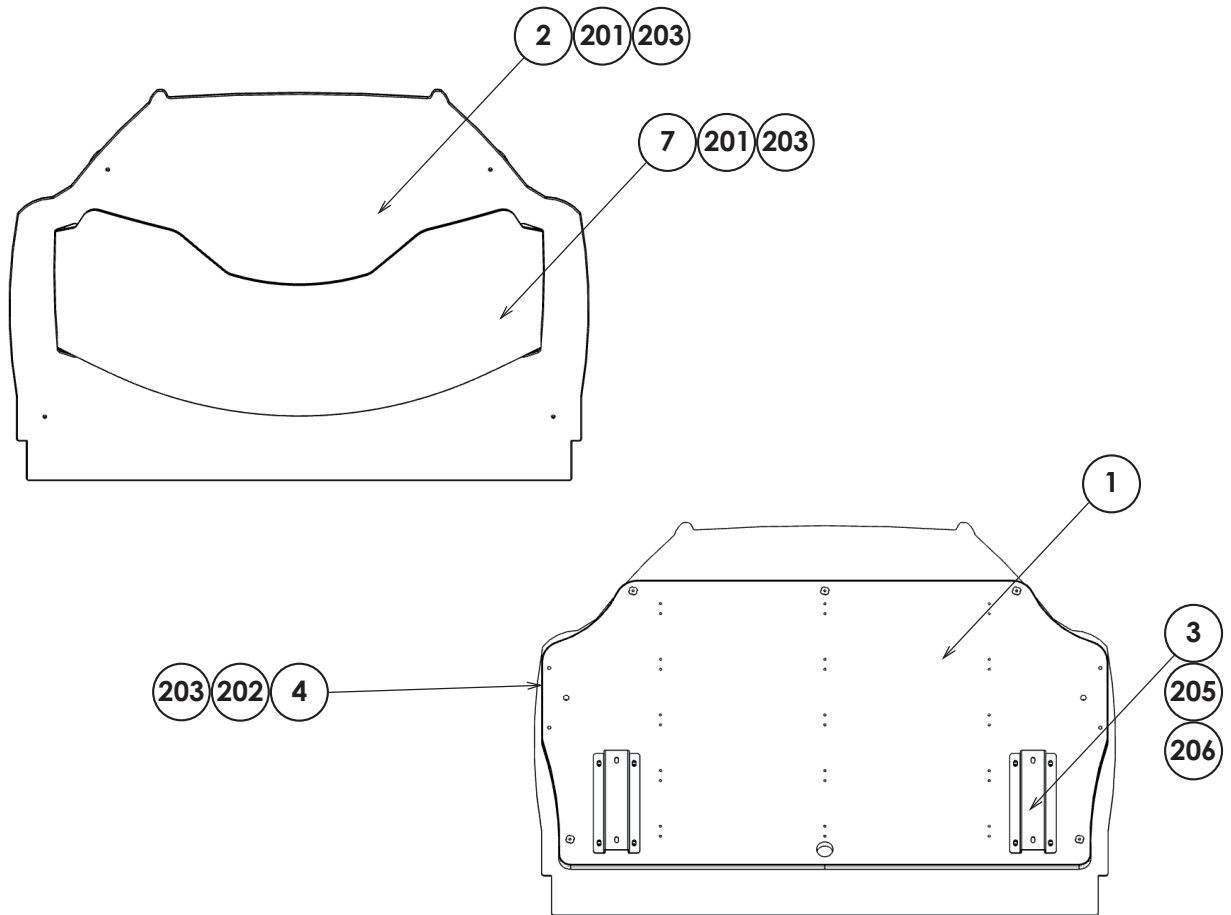

| ITEM NO | PART NO | DESCRIPTION | REFERENCE | QTY |
|---------|-----------------|-----------------------------|-----------|-----|
| ***1 | DA-7807UK | PANEL BILLBOARD | | 1 |
| ***2 | DA-7812UK | BILLBOARD HEADER | | 1 |
| ***3 | DA-7808UK | BRKT BILLBOARD | | 2 |
| ***4 | DA-7811UK | BRKT ARTWORK RETAINING | | 2 |
| ***7 | DA-7809UK | BILLBOARD BUMPER | | 1 |
| ***8 | 601-0460-150-N | CABLE TIE 150MM NATURAL | | 4 |
| ***101 | 280-L01030-OS | STANDOFF 10OD 5.2ID 30L | | 5 |
| ***102 | 601-0460 | CABLE TIE NYLON 100MM | | 15 |
| ***201 | 008-B00450 | M4X50 TMP BH PAS | | 7 |
| ***202 | 029-B00425 | M4X25 SKT BH PAS | | 4 |
| ***203 | 068-441616 | M4 WSHR 16OD FLT PAS | | 11 |
| ***205 | 029-B00625 | M6X25 SKT BH PAS | | 8 |
| ***206 | 068-652016 | M6 WSHR 20OD FLT PAS | | 8 |
| ***303 | DA-6008UK | ASSY BILLBOARD | | 5 |
| ****1 | 390-2112-090WUK | LED RIGID RIGID WHITE 900MM | | 1 |
| ****2 | DB-60120UK | WH BILLBOARD | | 1 |
| ***304 | DA-60125UK | WH BILLBOARD HEADLIGHTS | | 1 |
| ***305 | 390-2505-030-AD | SLED RING 030 M3028WS2812B | | 2 |

19 WIRE COLOUR CODE TABLE

WARNING

The DC power wire color for this product is different from previous SEGA titles.
Working from the previous wire colors will create a high risk of fire.

The color codes for the wires used in the diagrams in the following chapter are as follows:

| | |
|---|-------------|
| A | PINK |
| B | SKY BLUE |
| C | BROWN |
| D | PURPLE |
| E | LIGHT GREEN |

Wires other than those of any of the above 5 single colors will be displayed by 2 alphanumeric characters:

| | |
|---|--------|
| 1 | RED |
| 2 | BLUE |
| 3 | YELLOW |
| 4 | GREEN |
| 5 | WHITE |
| 7 | ORANGE |
| 8 | BLACK |
| 9 | GRAY |

If the right-hand side numeral of the code is 0, then the wire will be of a single color shown by the left-hand side numeral (see the above).

Note 1: If the right-hand side numeral is not 0, that particular wire has a spiral color code. The left-hand side character shows the base color and the right-hand side one (the spiral color).

<Example> 51.....WHITE/RED



Note 2: The character following the wire color code indicates the size of the wire.

| | |
|-------|-------|
| U: | AWG16 |
| K: | AWG18 |
| L: | AWG20 |
| None: | AWG22 |

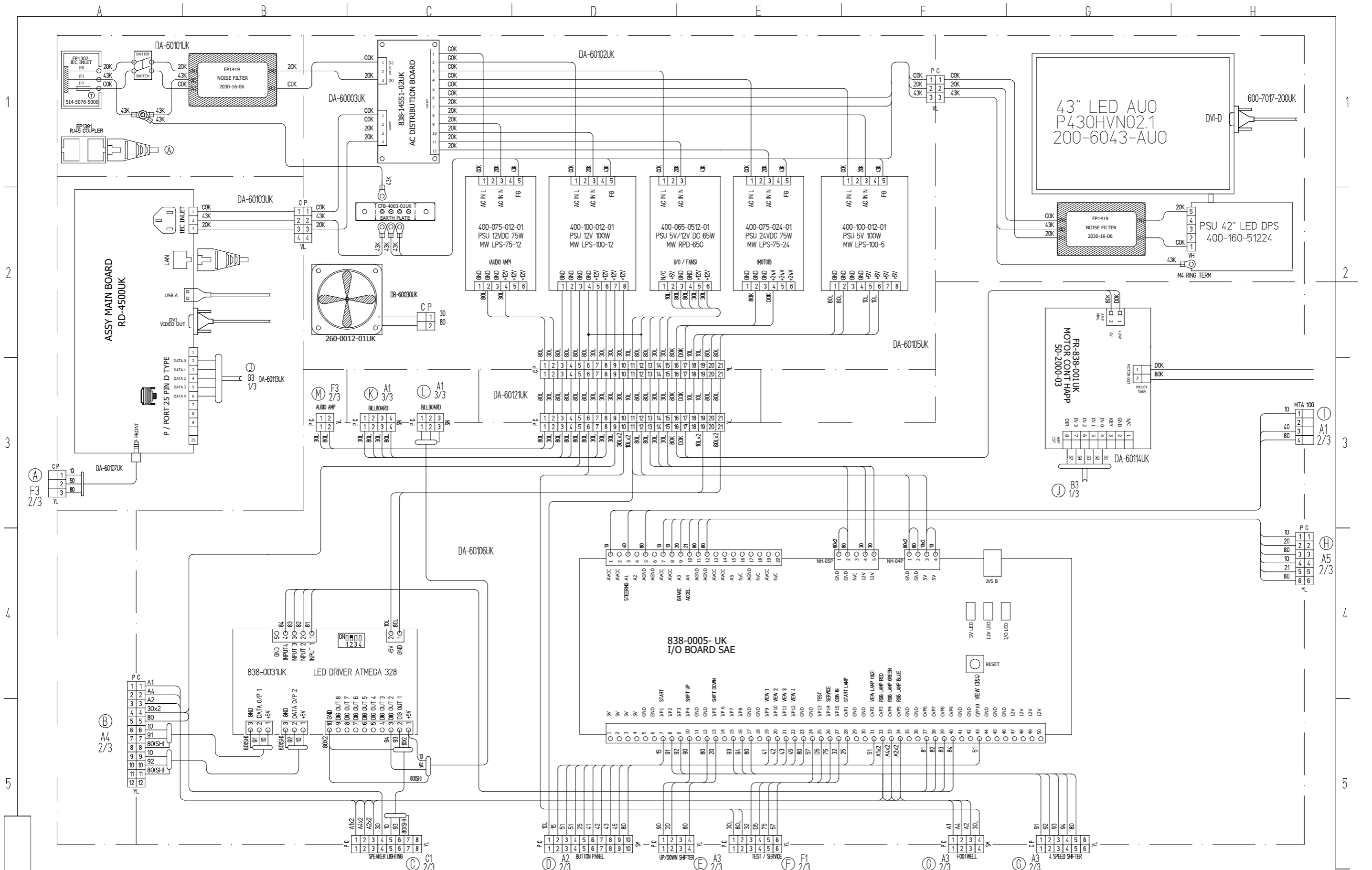

| | | | | | | | | | | | | | |
|-------------|--|------------|--|-----------------|--|-------|------|--------|------|------|------------------------------|--|------------------|
| 1 RED | | 8 BLACK | | E LIGHT GREEN | | DRAWN | CHKD | D/CHKD | APPR | SEGA | SEGA AMUSEMENTS EUROPE, LTD. | THIS DRAWING WILL IN NO WAY BE COPIED. TO BE RETURNED ON DEMAND. | ORIGINAL SIZE A3 |
| 2 BLUE | | 9 GREY | | | | | | | | | | | |
| 3 YELLOW | | A PINK | | U AWG 16 UL1015 | | RA | | | | | DAYTONA STREET CAB | PAGE 1 OF 3 | |
| 4 GREEN | | B SKY BLUE | | K AWG 18 UL1015 | | | | | | | | | |
| 5 WHITE | | C BROWN | | L AWG 20 UL1007 | | | | | | | | | |
| 7 ORANGE | | D PURPLE | | AWG 22 UL1007 | | | | | | | | | |
| ALTERATIONS | | | | | | | | | | | | | |
| COLOUR CODE | | | | | | | | | | | | | |
| WIRE TYPE | | | | | | | | | | | | | |
| DESCRIPTION | | | | | | | | | | | | | |
| PART NO. | | | | | | | | | | | | | |

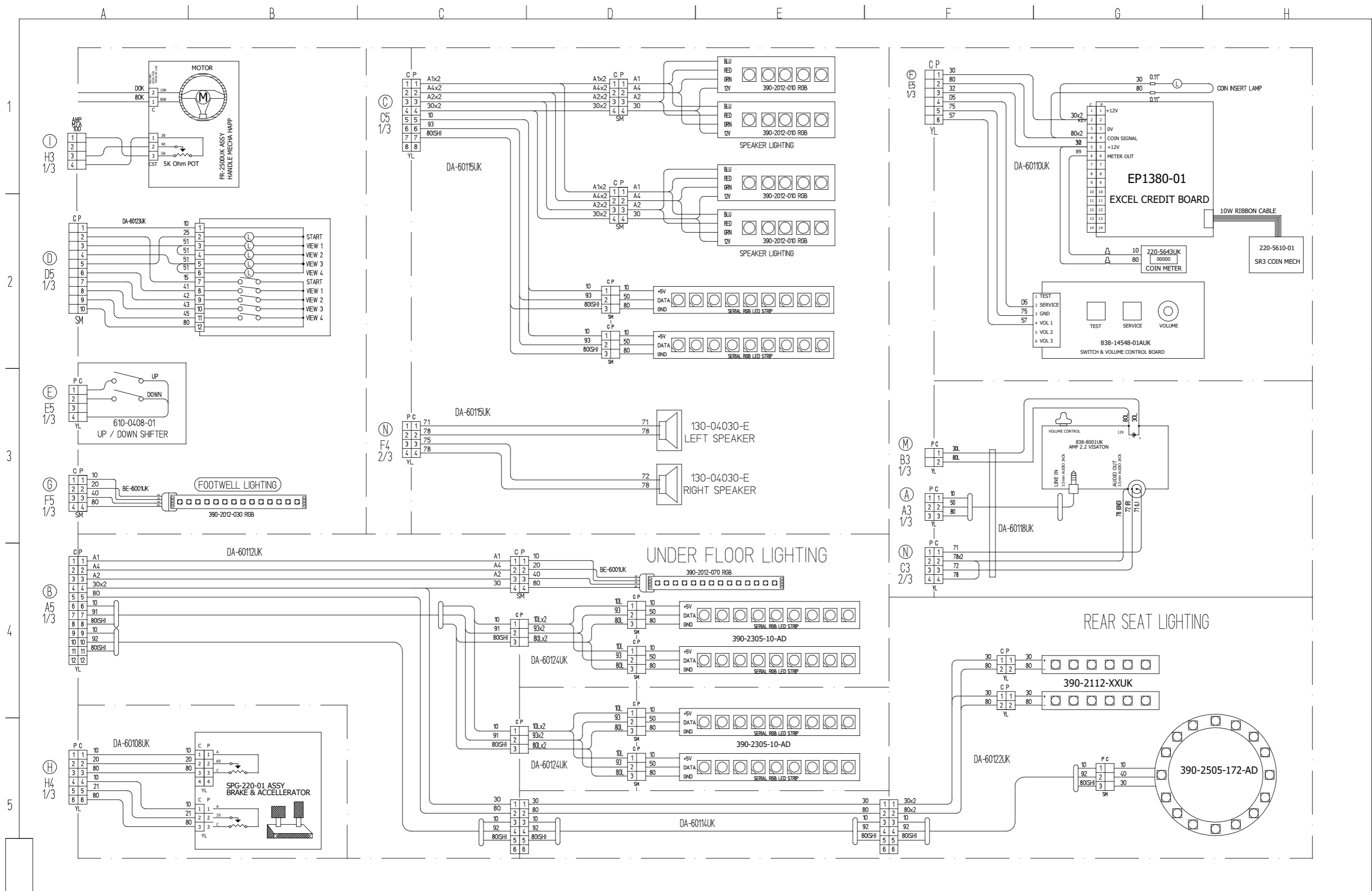

| | | | | | |
|---|--------|---|----------|---|---------------|
| 1 | RED | 8 | BLACK | E | LIGHT GREEN |
| 2 | BLUE | 9 | GREY | | |
| 3 | YELLOW | A | PINK | U | AWG 16 UL1015 |
| 4 | GREEN | B | SKY BLUE | K | AWG 18 UL1015 |
| 5 | WHITE | C | BROWN | L | AWG 20 UL1007 |
| 6 | ORANGE | D | PURPLE | | AWG 22 UL1007 |

| | |
|-------------|-----------|
| COLOUR CODE | WIRE TYPE |
| | |

| | | | |
|-------|------|--------|------|
| DRAWN | CHKD | D/CHKD | APPR |
| RA | | | |

SEGA SEGA AMUSEMENTS EUROPE, LTD.
DAYTONA STREET CAB

THIS DRAWING WILL IN NO WAY BE COPIED.
 TO BE RETURNED ON DEMAND.
 ORIGINAL SIZE
 A3
 PAGE 2 OF 2

PART NO.

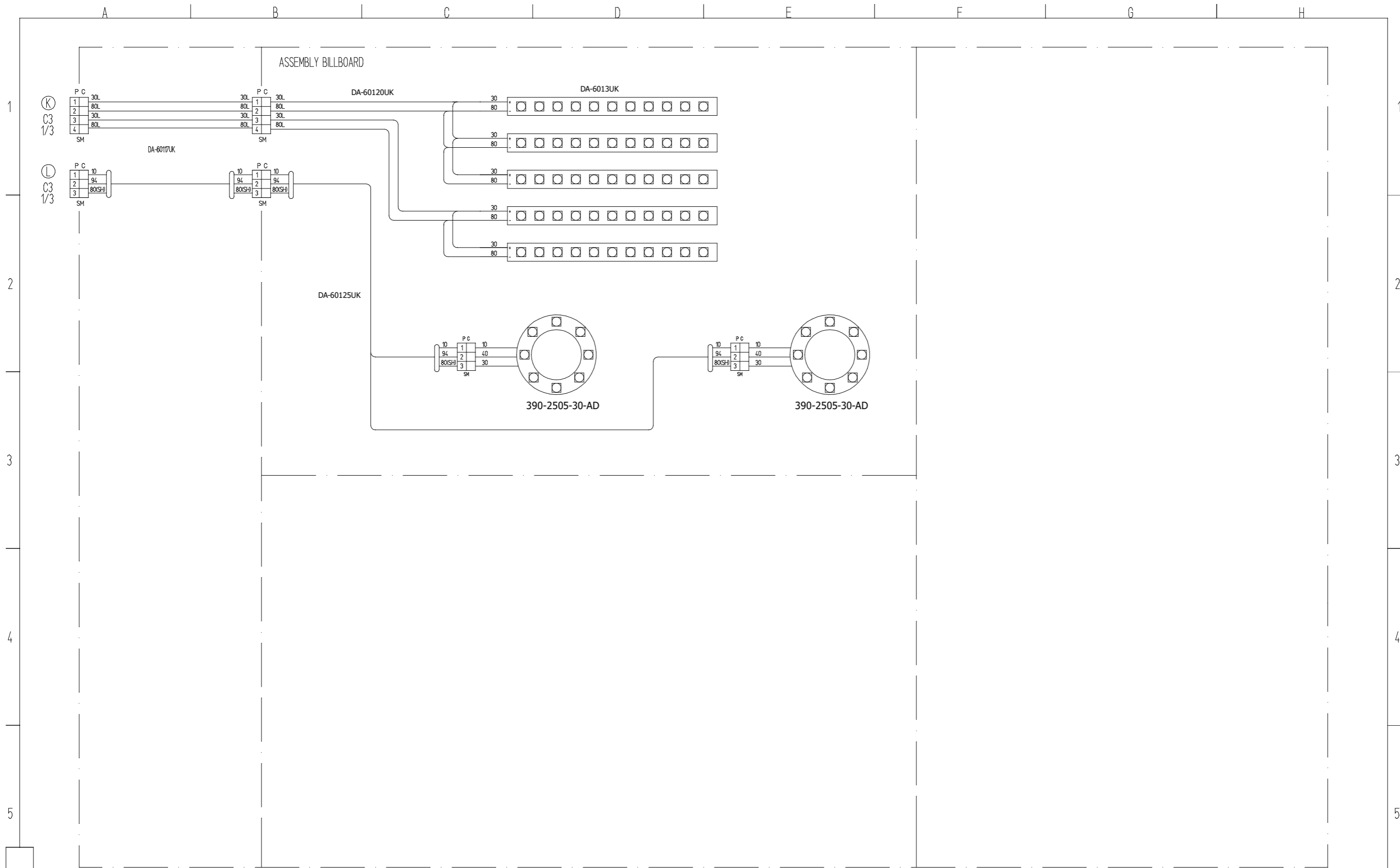

| | | | | | | | | | |
|-------------|--------|---|----------|-----------|-------------|---|--------|--------|--|
| 1 | RED | 8 | BLACK | E | LIGHT GREEN | | | | |
| 2 | BLUE | 9 | GREY | | | | | | |
| 3 | YELLOW | A | PINK | | | U | AWG 16 | UL1015 | |
| 4 | GREEN | B | SKY BLUE | | | K | AWG 18 | UL1015 | |
| 5 | WHITE | C | BROWN | | | L | AWG 20 | UL1007 | |
| 7 | ORANGE | D | PURPLE | | | | AWG 22 | UL1007 | |
| COLOUR CODE | | | | WIRE TYPE | | | | | |

| | | | |
|-------|------|--------|------|
| DRAWN | CHKD | D/CHKD | APPR |
| RA | | | |

SEGA SEGA AMUSEMENTS EUROPE, LTD.
 DAYTONA STREET CAB

THIS DRAWING WILL IN NO WAY BE COPIED.
 TO BE RETURNED ON DEMAND.
 PAGE 3 OF 3

ORIGINAL SIZE
 A3
 PART NO.

- SEGA TOTAL SOLUTIONS -

42 Barwell Business Park
Leatherhead Road,
Chessington,
Surrey,
KT9 2NY
United Kingdom

Tel: +44 (0) 208 391 8060
Fax: +44 (0) 208 391 8096



Exclusive Suppliers of SEGA Spares

To Heathrow Airport

