

1st PRINTING
AUGUST 2018

SEGA[®]

Sega Amusements International Limited.
42 Barwell Business Park, Leatherhead Road, Chessington, Surrey, KT9 2NY. United Kingdom.
Telephone: +44 (0) 208 391 8090 Facsimile: +44 (0) 208 391 8099
mailbox@sega.co.uk segaarcade.com

Sega Games Co., Ltd.
1-2-12, Haneda, Ota-ku, Tokyo, 144-8531. Japan.
Telephone: +81-3-5736-7111 Facsimile: +81-3-6871-7672
sega-games.co.jp

© SEGA
Errors and omissions excepted (E&OE)

HOUSE OF THE DEAD SCARLET DAWN

OWNER'S MANUAL

420-0032-01UK

SEGA[®]

OWNER'S MANUAL



IMPORTANT

- Before using this product, read this manual carefully to understand the contents herein stated.
- After reading this manual, be sure to keep it near the product or in a convenient place for easy reference when necessary.

TABLE OF CONTENTS

INTRODUCTION	iii
1 HANDLING PRECAUTIONS	1
2 PRECUATIONS REGARDING INSTALLATION	6
3 PRECAUTIONS REGARDING OPERATION	9
4 PARTS DESCRIPTION	13
5 ACCESSORIES	15
6 ASSEMBLY AND INSTALLATION	17
7 PRECAUTIONS WHEN MOVING	56
8 GAME DESCRIPTION	58
9 TEST AND SERVICE DATA	65
10 MONITOR	85
11 CONTROLLER UNIT	87
12 COIN HANDLING	101
13 PERIODIC INSPECTION	107
14 TROUBLESHOOTING	109
15 GAME BOARD	111
16 DESIGN RELATED PARTS	114
17 PARTS LIST	115
18 COLOUR CODE	158
19 SCHEMATIC DIAGRAMS	159

BEFORE USING THE PRODUCT, BE SURE TO READ THE FOLLOWING:

To maintain safety:

To ensure the safe operation of this product, be sure to read the following before usage: The following instructions are intended for the users, operators and the personnel in charge of the operation of the product. After carefully reading and sufficiently understanding the warning displays and cautions, handle the product appropriately. Be sure to keep this manual close to the product or in a convenient place for future reference.

Herein, explanations which require special attention are enclosed with dual lines. Depending on the potentially hazardous degrees, the terms of DANGER, WARNING, CAUTION, etc. are used. Be sure to understand the contents of the displays before reading the text.



Indicates that mishandling the product by disregarding this pictograph will cause severe injury or death.



Indicates that mishandling the product by disregarding this warning will cause a potentially hazardous situation which can result in death or serious injury.



Indicates that mishandling the product by disregarding this caution will cause a slight hazardous situation which can result in personal injury and/or material damage.

For the safe usage of the product, the following pictographs are used:



Indicates "HANDLE WITH CARE." In order to protect the human body and equipment, this display is attached to places where the instruction manual should be referred to.



Indicates a "protective earth terminal." Before operating the equipment, be sure to connect it to the ground (this step may be omitted for products in which a power cable with earth is used).

- **Perform work in accordance with the instructions herein stated.**
Instructions for work are explained by paying attention to the aspect of accident prevention. Failing to perform work as per the instructions can cause accidents. In the case where only those who have technical expertise should perform the work to avoid hazardous situation, the instructions herein state that the site maintenance personnel should perform such work.
- **Be sure to turn off the power before working on the machine.**
To prevent an electric shock, be sure to turn off the power and unplug the power cable before carrying out any work that requires direct contact with the interior of the product. If the work is to be performed in the power-on status, the instruction manual herein always states to that effect.
- **Be sure to ground the earth terminal (this is not required in the case where a power cable with earth is used).**
This product is equipped with the earth terminal. When installing the product, connect the earth terminal to the "accurately grounded indoor earth terminal" by using an earth wire. Unless the product is grounded appropriately, the user can be subject to an electric shock. After performing repair, etc. for the control equipment, ensure that the earth wire is firmly connected to the control equipment.
- **Ensure that the power supply used is equipped with an earth leakage breaker.**
Using a power supply which is not equipped with the earth leakage breaker can cause a fire when earth leakage occurs.
- **Be sure to use fuses which meet the specified rating (only for the machines which use fuses).**
Using fuses exceeding the specified rating can cause a fire and an electric shock.

- **Specification changes (removal of equipment, conversions and additions) not designated by SEGA are not allowed.**

The parts of the product include warning labels for safety, covers for personal protection, etc. It is very hazardous to operate the product by removing parts and/or modifying the circuits. Should doors, lids and protective parts be damaged or lost, refrain from operating the product, and contact where the product was purchased from or the office herein stated.

SEGA shall not be held responsible for any accidents or compensation for damage to a third party resulting from the specifications not designated by SEGA.

- **Ensure that the product meets the requirements of appropriate electrical specifications.**

Before installing the product, check for electrical specifications. SEGA products have a nameplate on which the electrical specifications are described. Ensure that the product is compatible with the power supply voltage and frequency requirements of the location. Using any electrical specifications different from the designated specifications can cause a fire and an electric shock.

- **Install and operate the product in places where appropriate lighting is available, allowing warning labels to be clearly read.**

To ensure safety for the customers, labels and printed instructions describing potentially hazardous situations are applied to places where accidents can be caused. Ensure that where the product is operated has sufficient lighting allowing the warnings to be read. If any label is peeled off, apply it again immediately. Please place an order with where the product was purchased from or the office herein stated.

- **When handling the monitor, be very careful (applies only to products with monitors).**

Some of the monitor parts are subject to high tension voltage. Even after turning off the power, some portions are still subject to high tension voltage. Monitor repair and replacement should be performed only by those technical personnel who have knowledge of electricity and technical expertise.

- **Be sure to adjust the monitor properly (applies only to products with monitors).**

Do not operate the product leaving on-screen flickering or blurring as it is. Using the product with the monitor not properly adjusted may cause dizziness or a headache to an operator, a player, or customer.

- **When transporting or reselling this product, be sure to attach this manual to the product.**

* *In the case where commercially available monitors and printers are used in this product, only the contents relating to this product are explained herein. Some commercially available equipment has functions and reactions not stated in this manual. Read this manual together with the specific instruction manual of such equipment.*

* *Descriptions herein contained may be subject to improvement changes without notice.*

* *The contents described herein are fully prepared with due care. However, should any question arise or errors be found, please contact SEGA.*

INSPECTIONS IMMEDIATELY AFTER TRANSPORTING THE PRODUCT TO THE LOCATION

Normally, at the time of shipment, SEGA products are in a status allowing for usage immediately after transporting to the location. Nevertheless, an irregular situation may occur during transportation. Before turning on the power, check the following points to ensure that the product has been transported in a satisfactory status:

- Are there any dented portions or defects (cuts, etc.) on the external surfaces of the cabinet?
- Are casters and adjusters damaged?
- Do the power supply voltage and frequency requirements meet with those of the location?
- Are all wiring connectors correctly and securely connected? Unless connected in the correct way, connector connections can not be made accurately. Do not insert connectors forcibly.
- Do power cables have cuts and dents?
- Are all accessories available?
- Can all doors and lids be opened with the accessory keys? Can doors and lids be firmly closed?

INTRODUCTION

This manual is intended to provide detailed descriptions together with all necessary information covering the general operation of electronic assemblies, electromechanical, servicing control, spare parts, etc. for the product: "HOUSE OF THE DEAD SCARLET DAWN"

This manual is intended for the owners, personnel managers in charge of operation of this product. Operate the product after carefully reading and sufficiently understanding the instructions.

In the unlikely event that the product does not function correctly, DO NOT allow anyone other than a technician to touch the internal system. Turn off the power to the machine, making sure to unplug the electrical cord from the outlet, and contact the office listed below or the point-of-purchase for this product.

Use of this product is unlikely to cause physical injuries or damage to property. However, points that require special attention are indicated by bold text, the words "STOP, IMPORTANT or CAUTION" and the symbols below.



Indicates important information that, if ignored, may result in the mishandling of the product and cause faulty operation or damage to the product.



Indicates a warning or caution that, if ignored, may result in the mishandling of the product and cause faulty operation or damage to the product.

Sega Amusements Europe Limited.

42 Barwell Business Park, Leatherhead Road, Chessington, Surrey, KT9 2NY. United Kingdom.

European Sales: +44 (0) 208 391 8090	Facsimile: +44 (0) 208 391 8099
USA Sales: +00 (1) 224 265 4287	
STS (Spares): +44 (0) 208 391 8060	Facsimile: +44 (0) 208 391 8096
email: mailbox@sega.co.uk	Web: http://www.segaarcade.com

SPECIFICATIONS

Standard Cabinet	
Machine Dimensions:	1.44m (56.6in) [Width] x 2.12m (83.4in) [Depth]
Machine Height:	2.29m (90.1in) (Installed)
Machine Weight:	510kg Approx (Installed)
Power, maximum current:	-466w-
Rating:	6.3A @ 115vac

Definition of 'Site Maintenance Personnel' or Other Qualified Individuals



Procedures not described in this manual or marked as 'to be carried out by site maintenance personnel or other qualified professionals' should not be carried out by personnel without the necessary skill or technological experience. Work carried out by unqualified persons may cause serious accidents, including electrocution.

Parts replacement, maintenance inspections and troubleshooting should be carried out by site maintenance personnel or other qualified professionals. This manual includes directions for potentially dangerous procedures which should only be carried out by professionals with the appropriate specialised knowledge.

The site maintenance personnel or other qualified professionals mentioned in this manual are defined as follows:

Site maintenance personnel:

Individuals with experience in maintaining amusement equipment, vending machines, etc., working under the supervision of the owner/operator of this product to maintain machines within amusement facilities or similar premises by carrying out everyday procedures such as assembly, maintenance inspections, and replacement of units/expendable parts.

Activities to be carried out by site maintenance personnel:

Amusement equipment/vending machine assembly, maintenance inspection and replacement of units/expendable parts.

Other qualified professionals:

Persons employed by amusement equipment manufacturers, or involved in design, production, testing or maintenance of amusement equipment. The individual should have either graduated from technical school or hold similar qualifications in electrical/electronics/mechanical engineering.

Activities to be carried out by other qualified professionals:

Amusement equipment/vending machine assembly, repair/adjustment of electrical/electronic/mechanical parts.

Waste of Electrical and Electronic Equipment (WEEE) Statement.

The WEEE (Waste of Electrical and Electronic Equipment) directive places an obligation on all EU based manufacturers and importers of Electrical and Electronic Equipment (EEE) to ensure waste equipment is disposed of in accordance with the directive at the end of their useful life.

The symbol shown below will be placed on all products manufactured from 13th August 2005, which indicates this product must NOT be disposed of with other normal waste. Upon purchasing any EEE from SEGA Amusements International Ltd. The user accepts responsibility to dispose of their waste equipment by arranging to return it to a designated UK collection point (AATF) or an Approved Exporter (AE) for the correct recycling of waste electrical and electronic equipment.

For more information on Approved Authorised Treatment Facilities (AATF) within the UK please consult the government website www.gov.uk

For users outside of the UK EEE should be disposed of in accordance with the local policy on the recycling of Waste Electrical and Electronic Equipment.

Battery Recycling Statement.

The EC Directive on Batteries and Accumulators (2006/66/EC) aims to minimise the impact of batteries on the environment and encourage the recovery of the materials they contain. To achieve increased collection and recycling of waste batteries, the Directive places 'producer responsibility' obligations on manufacturers and importers of portable, industrial and automotive batteries.

The symbol shown below will be on all equipment fitted with batteries from 26th September 2008 and indicates they must NOT be disposed of with other normal waste. Instead, it is the user's responsibility to dispose of used batteries by arranging to return them to a designated collection point for the correct recycling.

For more information about where you can send your waste batteries for recycling contact your local authority office.

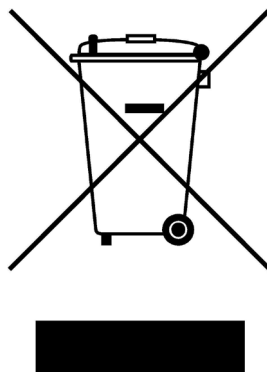

REGISTERED IN ENGLAND REGISTERED NO. 1711515

REGISTERED OFFICE: BLOCK C 42 BARWELL BUSINESS PARK, CHESSINGTON, SURREY KT9 2NY

1 HANDLING PRECAUTIONS

When installing or inspecting the machine, be mindful of the following points and pay attention to ensure that the player can enjoy the game safely.

Noncompliance with the following points or inappropriate handling running counter to the cautionary matters herein stated can cause personal injury or damage to the machine.

WARNING

- Before performing work, be sure to turn the power off. Performing the work without turning the power off can cause an electric shock or short circuit. In cases where work should be performed in the status of power on, this manual always states to that effect.
- To avoid an electric shock or short circuit, do not plug in or unplug quickly.
- To avoid an electric shock, do not plug in or unplug with a wet hand.
- Do not expose power cords or earth wires on the surface, (floor, passage, etc). If exposed, the power cords and earth wires are susceptible to damage. Damaged cords and wires can cause an electric shock or short circuit.
- To avoid causing a fire or an electric shock, do not put things on or damage the power cords.
- During or after installing the product, do not unnecessarily pull the power cord. If damaged, the power cord can cause a fire or an electric shock.
- In the case that the power cord is damaged, ask for a replacement through where the product was purchased from or the office herein stated. Using the cord as is damaged can cause fire, an electric shock or leakage.
- Be sure to perform grounding appropriately. Inappropriate grounding can cause an electric shock.
- Be sure to use fuses meeting the specified rating. Using fuses exceeding the specified rating can cause a fire or an electric shock.
- Be sure that connections such as IC BD are made properly. Insufficient insertion can cause an electric shock.
- Specification changes, removal of equipment, conversion and/or addition, not designated by SEGA are not permitted.
- Failure to observe this may cause a fire or an electric shock. Non-compliance with this instruction can have a bad influence upon the physical conditions of players or onlookers, or result in injury during play.
- SEGA shall not be held responsible for damage or compensation for damage to a third party caused by specification changes not designated by SEGA.
- Do not perform any work or change parts not listed in this manual. Doing so may lead to an accident.
- If you need to perform any work not listed in this manual, request work from the office indicated in this manual or the point of purchase, or inquires for details. Be sure to perform periodic maintenance inspections herein stated.

 **WARNING**

- Do not touch undesignated places. Touching places not designated can cause electric shock or short circuit.
- Whenever any fasteners (e.g. screws, nuts) have been lost, be sure to use replacement fasteners with proper dimensions as specified in this manual. If fasteners of any other dimensions are used, it could cause damage and/or separation of parts that result in secondary accidents.
- Specification changes, removal of equipment, conversion and/or addition, not designated by SEGA are not permitted.
- Failure to observe this may cause a fire or an electric shock. Non-compliance with this instruction can have a bad influence upon the physical conditions of players and onlookers, or result in injury during play.
- SEGA shall not be held responsible for damage or compensation for damage to a third party caused by specification changes not designated by SEGA.
- Performing work or parts replacements not described in this manual could result in accidents. If you need to perform any work not listed in this manual, request work from the office indicated in this manual or the point-of-purchase, or inquires for details.
- Be sure to perform periodic maintenance inspections herein stated.

 **IMPORTANT**

- For the IC board circuit inspections, only the use of a logic tester is recommended. Using a Multi-Tester or General Purpose Tester may result in damage to IC Circuits.
- Static electricity from your body may damage some electronic devices on the IC board. Before handling the IC board, touch a grounded metallic surface so that the static electricity can be discharged.
- Some parts are not designed or manufactured specifically for this game machine. The manufacturers may discontinue or change the specifications of such general-purpose parts. If this is the case, SEGA cannot repair or replace a failed game machine whether or not a warranty period has expired.

CONCERNING THE STICKER DISPLAY

This SEGA product has stickers attached describing the product manufacture No. (Serial No.) and Electrical Specifications. It also has a Sticker describing where to contact for repair and for purchasing parts.

When inquiring about or asking for repairs, mention the Serial No. and Name of Machine indicated on the Sticker. The Serial Number indicates the product register. Identical machines could have different parts depending on the date of production. Also, improvements and modifications might have been made after the publication of this manual. In order to ensure you order the correct parts, mention the Serial No. when contacting the applicable places.

CONCERNING WARNING DISPLAYS

This SEGA product has warning displays on stickers, labels and/or printed instructions adhered/attached to or incorporated in the places where a potentially hazardous situation could arise. The warning displays are intended for accident prevention for customers and for avoiding hazardous situations relating to maintenance and servicing work. Some portions of the cabinet contain high voltage and may cause accidents if touched. When performing maintenance, be very careful of the warning displays. It is especially important that any complex repair and replacement work not mentioned herein should be performed by those technical personnel who have knowledge of electricity and has technical expertise.

In order to prevent accidents, caution any customer ignoring the warnings to cease and desist immediately.

→ HANDLING PRECAUTIONS

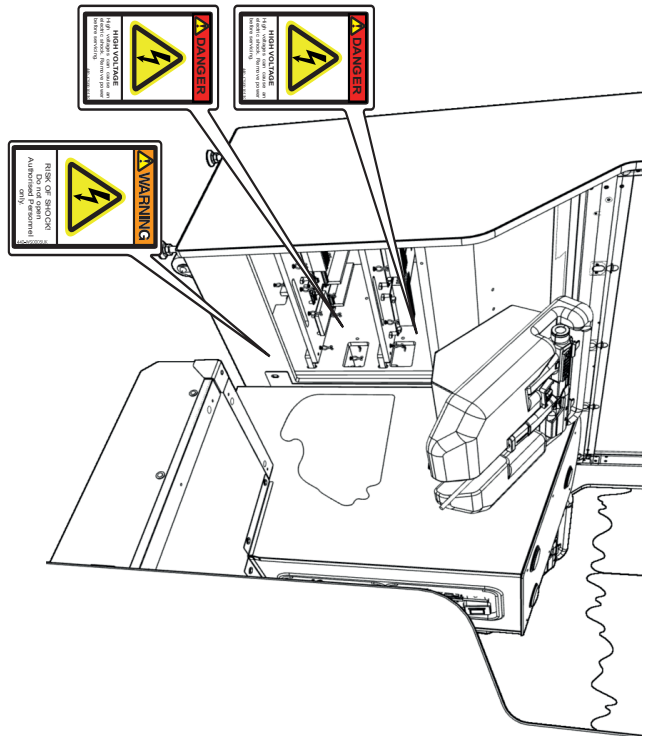
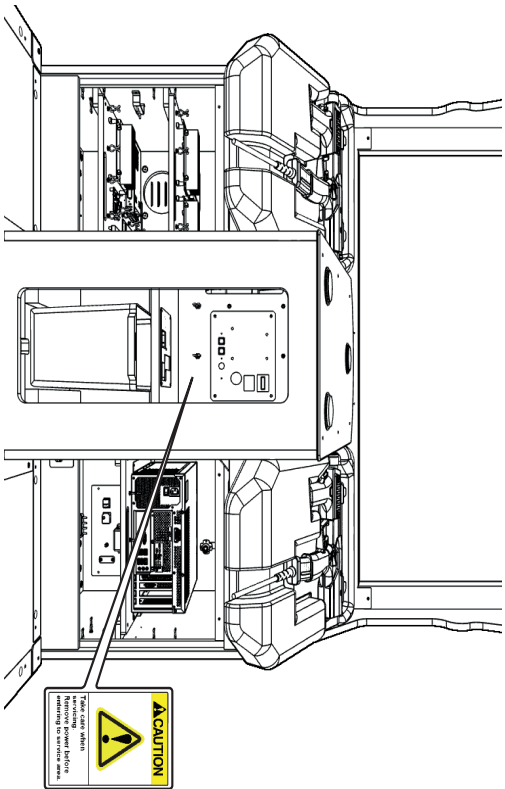
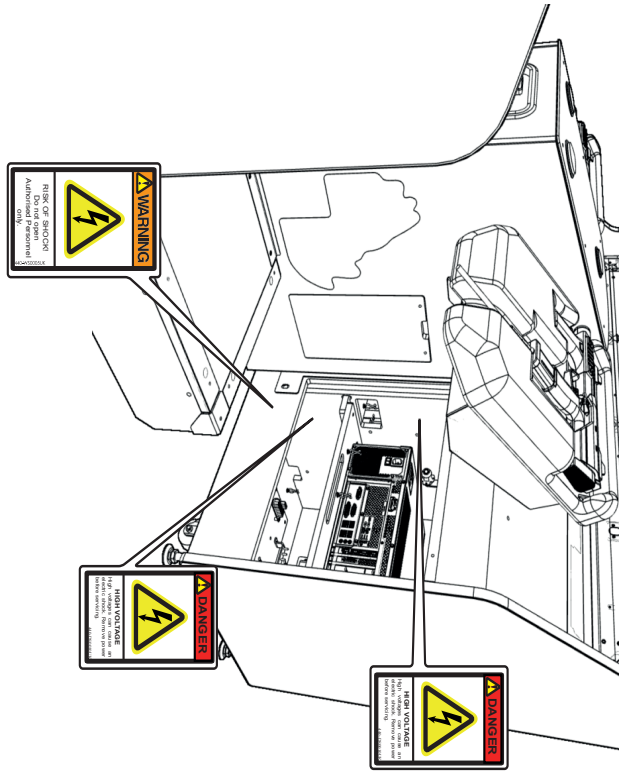
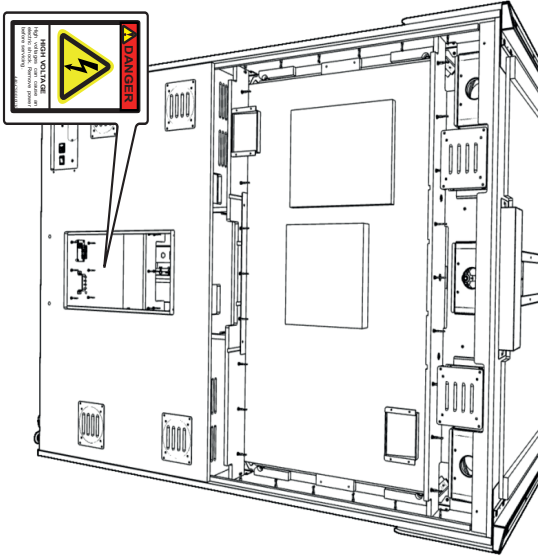

→ HANDLING PRECAUTIONS

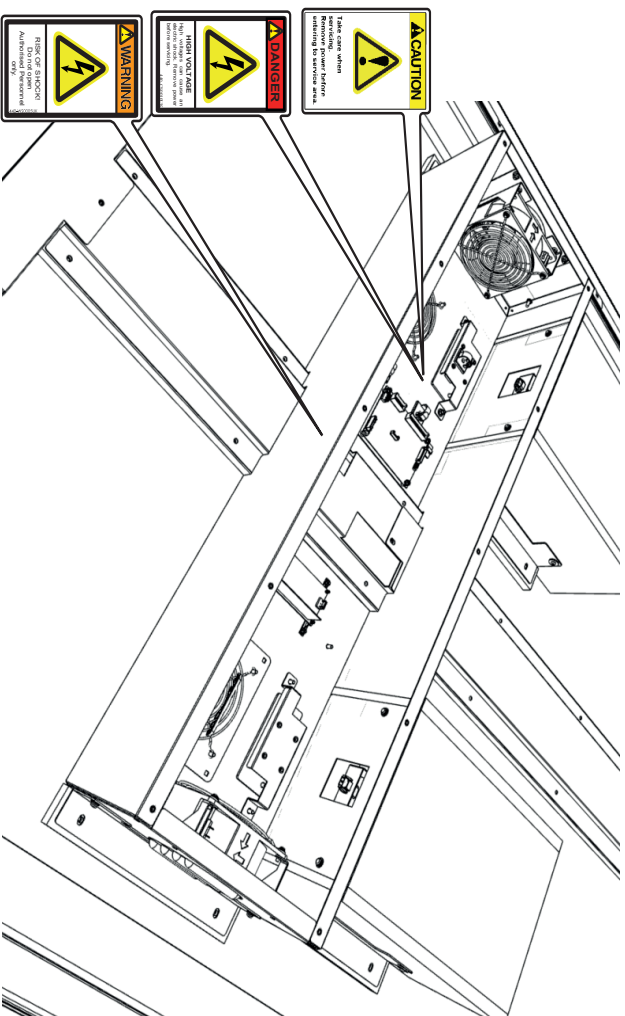
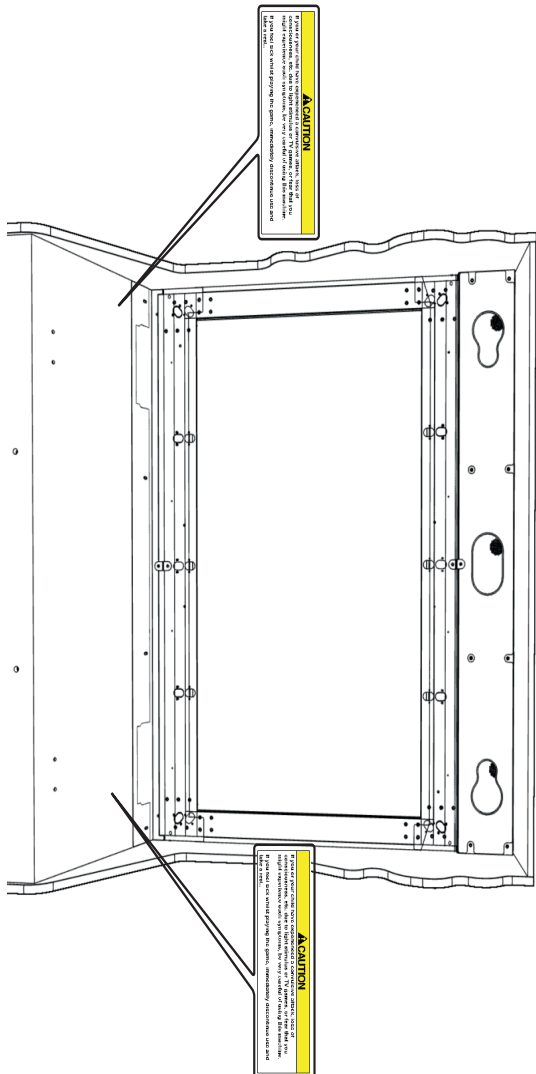
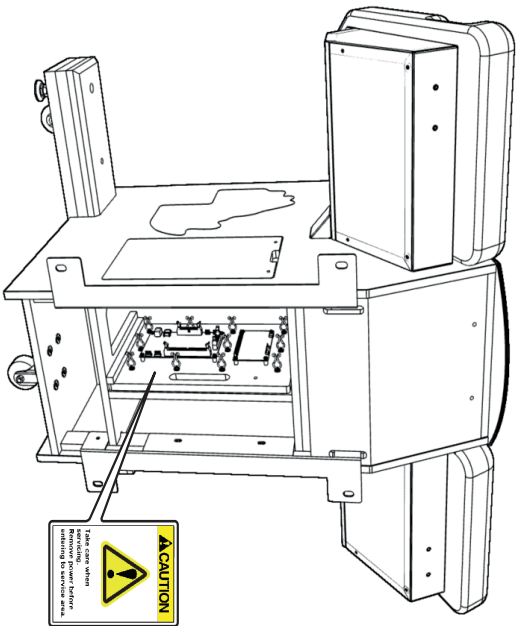
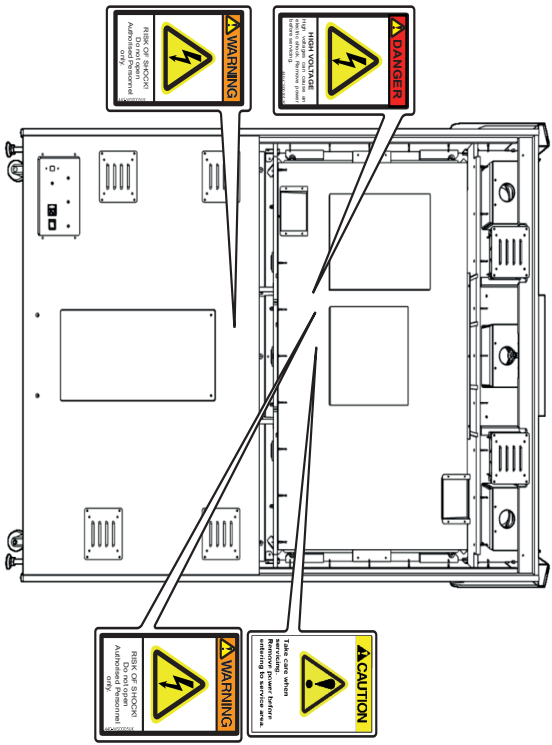

2 PRECAUTIONS REGARDING INSTALLATION

WARNING

- This product is an indoor game machine. Do not install it outside. Even indoors, avoid installing in places mentioned below so as not to cause fire, electric shock, injury and/or malfunction:
- Places subject to rain/water leakage or places subject to high humidity, in the proximity of an indoor swimming pool and/or shower, etc
- Places subject to direct sunlight or places subject to high temperatures, in the proximity of heating units, etc
- Places filled with inflammable gas or vicinity of highly inflammable/volatile chemicals or hazardous matter
- Dusty places
- Sloped surfaces
- Places subject to any type of violent impact
- Vicinity of anti-disaster facilities such as fire exits and fire extinguishers
- Areas where the temperature exceeds the applicable temperature (ambient temperature) range of 5 to 30 degrees centigrade

LIMITATIONS OF USAGE

WARNING

- Be sure to check the Electrical Specifications. Ensure that this product is compatible with the location's power supply, voltage, and frequency requirements. A plate describing Electrical Specifications is attached to the product. Noncompliance with the Electrical Specifications can cause a fire and electric shock.
- This product requires a breaker and earth mechanism as part of the location facilities. Using the product without these can cause a fire and electric shock.
- Ensure that the indoor wiring for the power supply is rated at 15 A or higher (AC single phase 100 V ~ 120 V area), and 7 A or higher (AC 220 V ~ 240 V area). Noncompliance with the Electrical Specifications can cause a fire and electric shock.
- Be sure to use an independent power supply equipped with an earth leakage breaker. Using a power supply without an earth leakage breaker can cause an outbreak of fire if a power surge occurs.
- Putting many loads on one electrical outlet can cause generation of heat and a fire resulting from overload.
- When using an extension cord, ensure that the cord is rated at 15 A or higher (AC 100 V ~ 120 V area) and 7 A or higher (AC 220 V ~ 240 V area). Using a cord rated lower than the specified rating can cause a fire and electric shock.

STOP IMPORTANT

Securing a safe area for operation as described in this manual will ensure safe operation for players and observers.

SEGA shall not be held responsible for damage or compensation for damage to a third party, resulting from the failure to observe this instruction.

OPERATION AREA (SINGLE CABINET)

WARNING

- For safe operation, use and operate this product in an area measuring at least 2.84 m (112.2 in) in width and 2.82 m (111 in) in depth when the cabinet is installed. SEGA shall not be held responsible for damage or compensation for damage to a third party, resulting from the failure to observe this instruction.
- The ceiling where this product is installed must be at least 2.3 m (90.5 in) high. If the ceiling is too low, the heat emitted from the product may cause it to catch on fire.
- Be sure to provide the sufficient space specified in this manual. Do not allow objects to block the ventilation ports. This can cause generation of heat and a fire.
- Put the cabinets close together so that people cannot get through or provide enough space between them that people can go both ways without difficulty. If the cabinets are installed carelessly, people may bump into each other or the cabinets when passing between them or fall down. To prevent people from walking between them, place them 0.15 m (5.9 in) apart.
- If the machine does not fit through the entryway to the installation location, do not disassemble it without first consulting the instructions. Specific tools and adjustment procedures are required to assemble and disassemble the mechanical parts. Attempting to assemble or disassemble the machine without consulting the instructions may result in accidents during assembly/disassembly, electric shock, short circuits, and/or personal injury during operation. If the machine still does not fit through the entryway after following the procedures in this manual, contact your retailer or the office listed in this manual.
- If the machine is still too large to fit through the entryway after following the procedures listed in this manual, do not tip the machine on its side. Attempting to transport the machine while it is tipped on its side may cause accidents. It may also damage or warp parts of the machine, resulting in accidents during operation.

⚠ WARNING

- To install this product, the entrance must be at least 0.75m (29.5 in) in width and 1.9m (74.8 in) in height (without Assy Billboard) and 2.3m (90.5 in) (with Assy Billboard). If the entrance is too narrow, do not tilt the product carelessly. If all the product weight is put on the casters at one side only, there could be damage or deformation, causing serious accidents such as workers getting caught underneath.

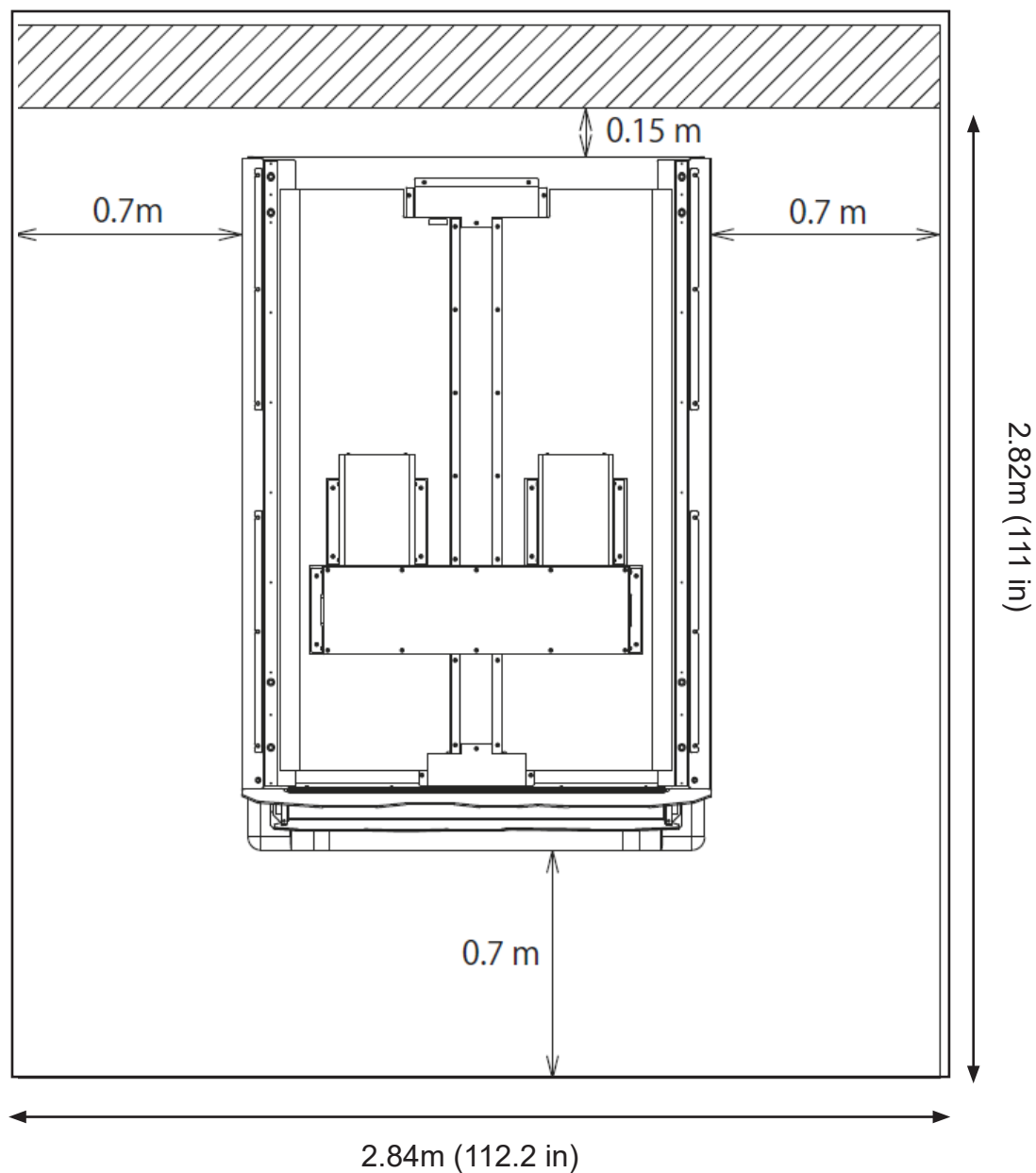

3 PRECAUTIONS REGARDING OPERATION

To avoid injury and trouble, be sure to pay attention to the behaviour of visitors and players.

3-1 BEFORE OPERATION

WARNING

- In order to avoid accidents, check the following before starting the operation:
- To ensure maximum safety for the players and the customers, ensure that where the product is operated has sufficient lighting to allow any warnings to be read. Operation under insufficient lighting can cause bodily contact with each other, hitting accident, and/or trouble between customers.
- Be sure to perform appropriate adjustment of the display (LCD, Plasma, CRT or Projector). For operation of this machine, do not leave monitor's flickering or deviation as is. Failure to observe this can have a bad influence upon the players' or customers' physical conditions.
- It is suggested to ensure a space allowing the players who feel sick while playing the game to take a rest.
- Check if all of the adjusters are in contact with the surface. If they are not, the Cabinet can move and cause an accident.
- Do not put any heavy item on this product. Placing any heavy item on the product can cause a falling down accident or parts damage.
- Do not climb on the product. Climbing on the product can cause falling down accidents. To check the top portion of the product, use a step/stepladder.
- To avoid electric shock, check to see if door and cover parts are damaged or omitted.
- Do not place the following items on top of or near the product or hang them from the ceiling. Doing so could result in electric shock, short circuits and/or damage to the parts:
- Flower vases, flowerpots, cups, water tanks, cosmetics, and receptacles/containers/vessels containing chemicals and water.

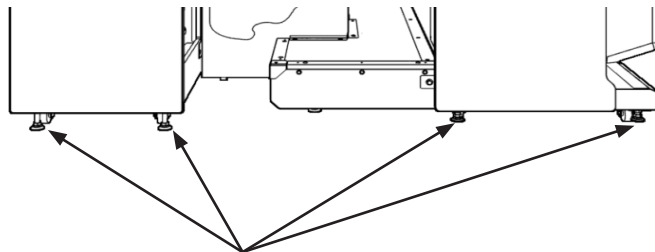

Each leg adjuster **MUST** be lowered so that the casters are raised approximately 5mm off the floor

⚠ CAUTION

- To avoid injury, be sure to provide sufficient space by considering the potentially crowded situation at the installation location. Insufficient installation space can cause contact, collisions, and/or trouble between customers.
- During daily cleaning, be sure to check the surface of the control unit and other parts that the player touches with his/her hands for damage, cracks, or loose screws. If a player uses the machine while it is damaged, cracked, or has a loose screw, the player may become injured.

Ensure that the screws are not loose and are all present.

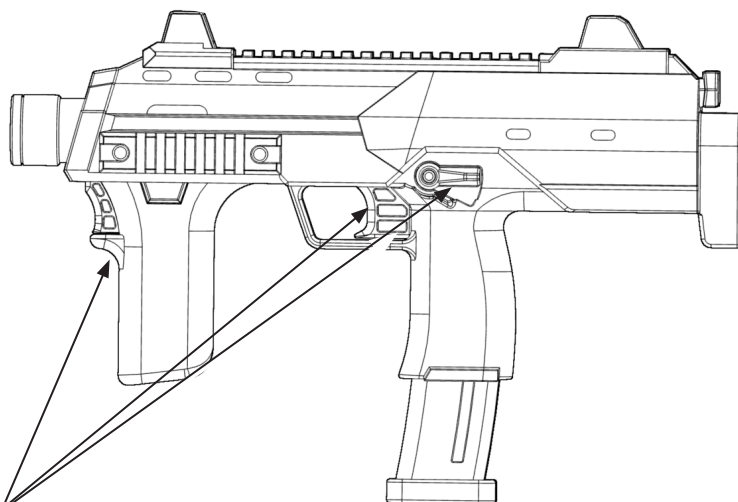

Ensure that there is no damage to cable connectors.

Ensure that all buttons are functioning correctly.

- Check carefully to make sure there are no gaps in the cabinet joints and that they are not loose. If there are gaps or looseness, players may get their hands or fingers caught, resulting in an injury.
- Make sure all the doors are locked securely and they do not rattle. If the doors are not locked properly or there are gaps or rattling, players could get their fingers or hands caught.
- Be sure to perform appropriate adjustment of the LCD. For operation of this machine, do not leave monitor's flickering or deviation as is. Failure to observe this can have a bad influence upon the players' or customers' physical conditions.
- Inspect for the following items during a trial run. If there is any type of error, use the Test Mode, etc. to resolve the problem. If you continue use with an error, it can cause an accident or irreparable parts damage:
 - Is there any strangeness in the operability of the control unit?
 - Is there any improper adjustment of the LCD screen?
- Prepare a place where players can rest if they feel sick.

3-2 PAYING ATTENTION TO CUSTOMERS

To avoid injury and trouble, be sure to constantly give careful attention to the behaviour and manner of the visitors and players.

DURING OPERATION (PAYING ATTENTION TO CUSTOMERS)

WARNING

- For safety reasons, do not allow any of the following people to play the game:
 - Those who have high blood pressure or a heart problem.
 - Those who have experienced muscle convulsion or loss of consciousness when playing video games, etc.
 - Those who have neck or spinal cord problems.
 - Those who are intoxicated or under the influence of drugs.
 - Pregnant women.
 - Those who are not in good health.
 - Those who do not follow the attendant's instructions.
 - Those who cannot grasp the Control Unit securely because of immobility in fingers, hands or arms.
 - Persons who disregard the product's warning displays.
- Even players who have never been adversely affected by light stimulus might experience dizziness or headache depending on their physical condition when playing the game.

Small children are especially likely to experience these symptoms. Caution guardians of small children to keep watch over them during play.

- Instruct those who feel sick during play to have a medical examination.
- To avoid injury from falls and electric shocks due to spilled drinks, instruct the player not to place heavy items or drinks on the product.
- To avoid electric shocks and short circuits, do not allow customers to put hands, fingers or extraneous matter in the openings of the product or small openings in and around the doors.
- To avoid falls and resulting injury, immediately stop the customer from leaning against or climbing on the product, etc.
- To avoid electric shock and short circuit, do not allow customers to unplug the power plug without a justifiable reason.
- Instruct the guardians of small children to keep watch over their children.

Children cannot sense danger. Allowing small children to get near a player who is playing the game could result in the children being bumped, struck or knocked down.

STOP IMPORTANT

- Players directly hold the control unit with their bare hands, so it is recommended that wet towels (paper towels) be provided.
- Diligently clean the parts that players touch directly to ensure a pleasant game playing experience.
- Inspect the coin insertion slots to make sure no foreign objects have been inserted and that they have not otherwise been tampered with as this will prevent play.



CAUTION

- Immediately stop such violent acts as hitting and kicking the product. Such violent acts can cause parts damage or falling down, resulting in injury due to fragments and falling down.
- Persons other than the player should not be allowed to touch the controls during play. They may brush against or collide with the controls or the player, possibly resulting in accidents.
- Instruct those who feel sick during play to have a medical examination.
- Immediately stop users from leaning or sitting on the control panel. Such acts can lead to injury or damage to parts or the shape of the cabinet.
- Immediately stop users from swinging or reloading the control unit in a violent manner. Such acts may hurt the user or other people around them.
- Playing too close to the cabinet may cause the control unit to hit the cabinet and cause damage. Make sure that players understand to play at a safe distance from the cabinet.
- Make sure that players understand not to stand too close together when playing a 2 player game. Swinging the control unit could lead to a player getting hit and may cause injury.
- Instruct players to hold the control unit securely while playing. If the control unit is dropped, it could cause injury to the player.
- Items such as large finger rings can cause injury to the fingers while playing. Instruct players to remove all accessories that could cause an accident before playing.
- Instruct players that a single control unit is never to be held by 2 or more people during play. Otherwise there could be dangerous contact or a collision.

STOP IMPORTANT

The control units for use on 1P side (left side) and 2P side (right side) are different. Ensure that players do not confuse the right and left side control units when starting play.

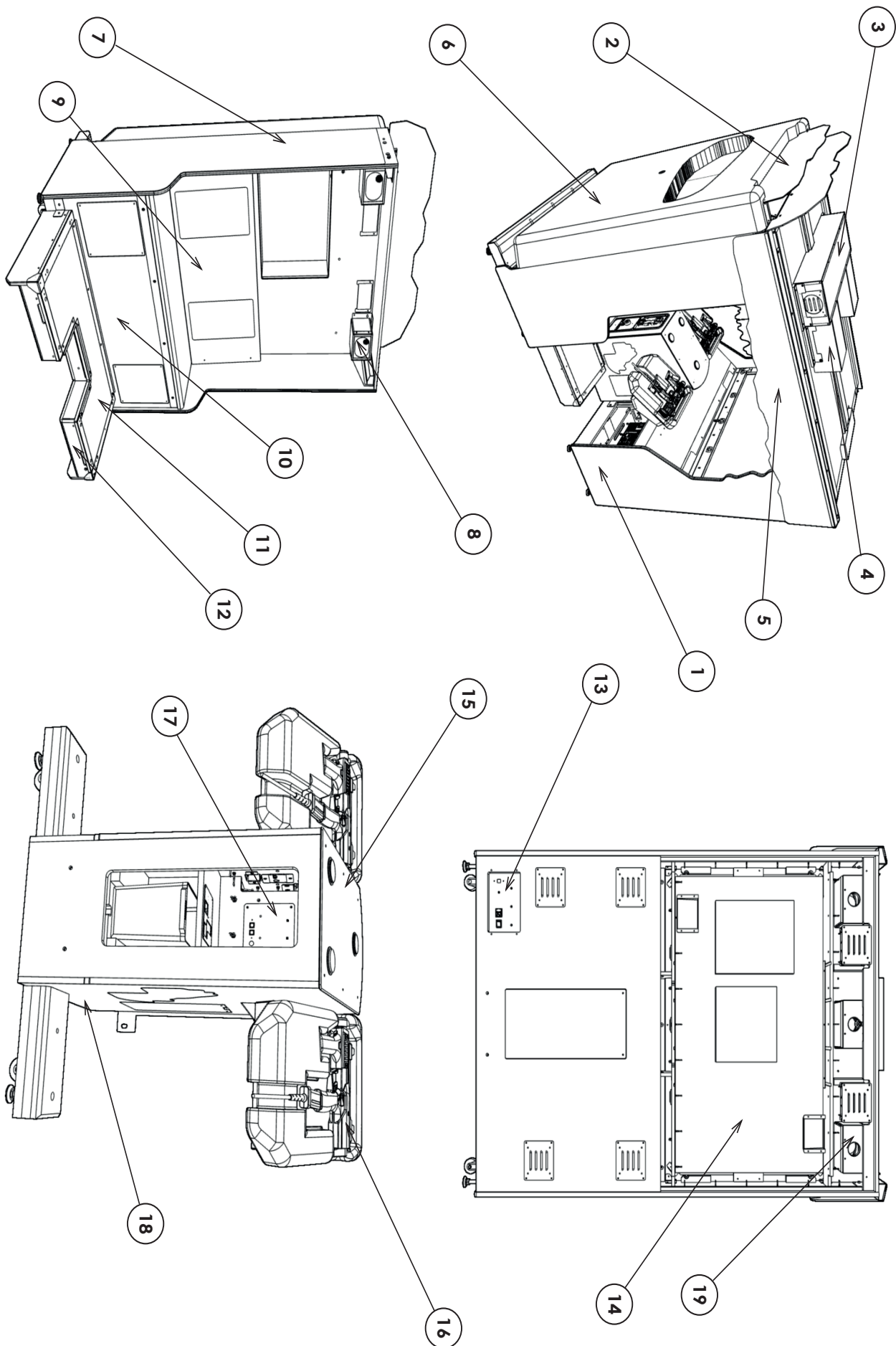
4 PART DESCRIPTIONS





4 PART DESCRIPTIONS

1	MONITOR CAB
2	BILLBOARD
3	ROOF BOX
4	AIR BOX
5	CURTAIN
6	REAR MOULDING
7	REAR CABINET
8	REAR SPEAKER
9	BACKREST
10	SEAT
11	FLOOR
12	STEP
13	AC UNIT
14	MONITOR
15	CONTROL PANEL
16	CONTROL UNIT
17	SW UNIT
18	CONTROL CAB
19	MONITOR SPEAKER

5 ACCESSORIES

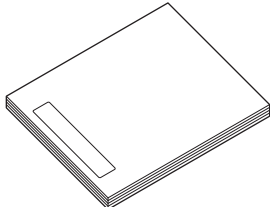
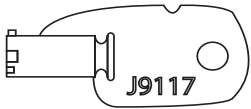
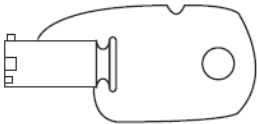
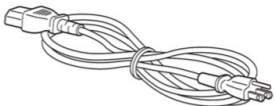
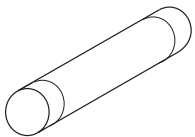
Confirm that the accessories listed in the table below are present when setting up the product.
Accessories marked “Spare” are consumable items but included as spares.

Part name / number	Diagram	Quantity
Owner's Manual (Part #: 420-0032-01UK)		1
Master key		6
Security Key		2
Power Lead UK (Pt No LM1227) EU (Pt No LM1246) US (Pt No LM12XX)		1ea
Spare Fuse (Fitted to ASSY AC UNIT)		1
Epilepsy Warning Labels (multi-lingual)		1

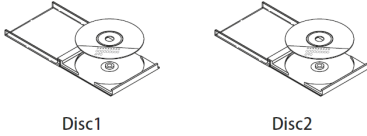
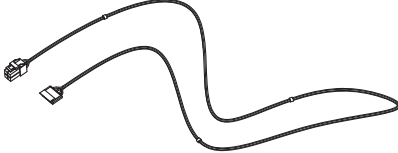
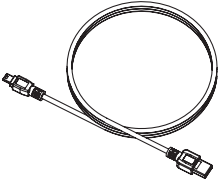
Part name / number	Diagram	Quantity
<p>DVD Software Kit 610-0945-0005</p>	 <p>Disc1 Disc2</p>	<p>1ea</p>
<p>Software Install Cable</p>		<p>1</p>
<p>Software USB Cable</p>		<p>1</p>

6 ASSEMBLY AND INSTALLATION

WARNING

- Perform assembly work by following the procedure herein stated. Failure to comply with the instructions can cause electric shock.
- Perform assembling as per this manual. Since this is a complex machine, incorrect assembling can cause an electric shock, machine damage and/or improper functioning as per specified performance.
- When assembling, more than one person is required. Depending on the assembly work, there are some cases in which working by one person alone can cause personal injury or parts damage.
- Ensure that connectors are properly connected. Improper connections can cause electric shock.
- Be careful not to damage the wires. Damaged wires may cause electric shock or short circuit or present a risk of fire.
- This work should be carried out by site maintenance personnel or other qualified professionals. Work performed by non-technical personnel can cause a severe accident such as electric shock. Failing to comply with this instruction can cause a severe accident such as electric shock to the player during operation. If no one with proper technological expertise is available, request service from the office indicated in this document or the point of purchase so as to ensure safety.
- Provide sufficient space so that assembling can be performed. Performing work in places with narrow space or low ceiling may cause an accident and assembly work to be difficult.
- To perform work safely and avoid serious accident such as the cabinet falling down, do not perform work in places where step-like grade differences, a ditch, or slope exist.
- Do not leave power cords or Ground Wires exposed in areas of heavy foot traffic. Doing so may cause them to become damaged, possibly resulting in electric shock and/or short circuits. When laying wiring across the floor, always use safety covers to protect the wires. (Wiring diameter: power cable - approx. \varnothing 8)
- Have a flashlight or another supplementary lighting unit available while working. With indoor lighting alone, the cabinet interior may be too dark. Working without proper lighting can lead to accidents. It also hinders proper work performance.
- The cabinet has ventilation ports. Be sure not to block them. If they are blocked, heat can build up, leading to fire. This can also accelerate wearing of parts and malfunctions.
- Secure ample ventilation space around the cabinet. If heat builds up, there could be accidents associated with heat or smoke generation.
- Do not unnecessarily push the projector. This could cause the unit to tip over.
- This product does not use any connectors other than those connected to and used by the game board when it leaves the factory. Do not needlessly connect wires to unused connectors. This could lead to overheating, generation of smoke and burn related injuries.

 **CAUTION**

- Handle molded parts with care. Excessive weight or pressure may cause them to break and the broken pieces may cause injury.
- To perform the operation safely and accurately you must use a safe, steady footstool or stepladder. Working without this may lead to a fall and possible injury.
- When connecting the connectors on the DVD wire, you must carefully check the tags on the wire to find the correct connector. Even when you have the correct connector, you must pay careful attention to the direction and angle of insertion. Attempting to forcefully connect the incorrect connector or connecting a connector at the wrong angle or facing may damage the connector and could lead to overheating and burn related injuries.
- When attaching or removing doors or lids, be careful that your hand or finger does not get caught in anything.

 **IMPORTANT**

- Be very careful when handling the LED display screen. The screen can be damaged easily and cannot be repaired once damaged. Such damage can only be repaired by completely replacing the screen.
- Be careful not to damage parts surfaces. In some cases, if such surfaces are damaged, the part must be replaced; it cannot be reinforced or repaired.

6-1 CONTROL CAB INSTALLATION

Carry out this operation with 2 or more people.

- 1 Ensure the four adjusters on the bottom of the Monitor Cabinet are touching the floor.

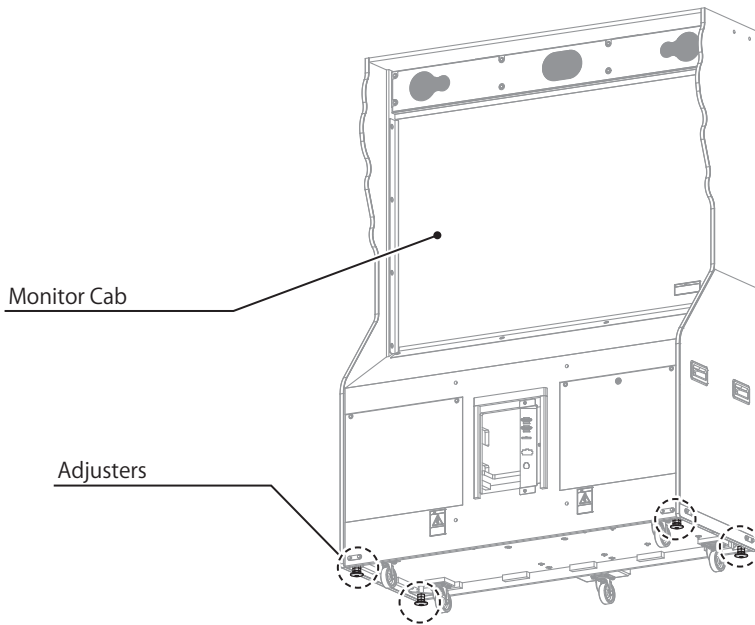

- 2 Have 2 people hold the handles of the Control Cabinet and place it on the guide of the Monitor Cabinet.

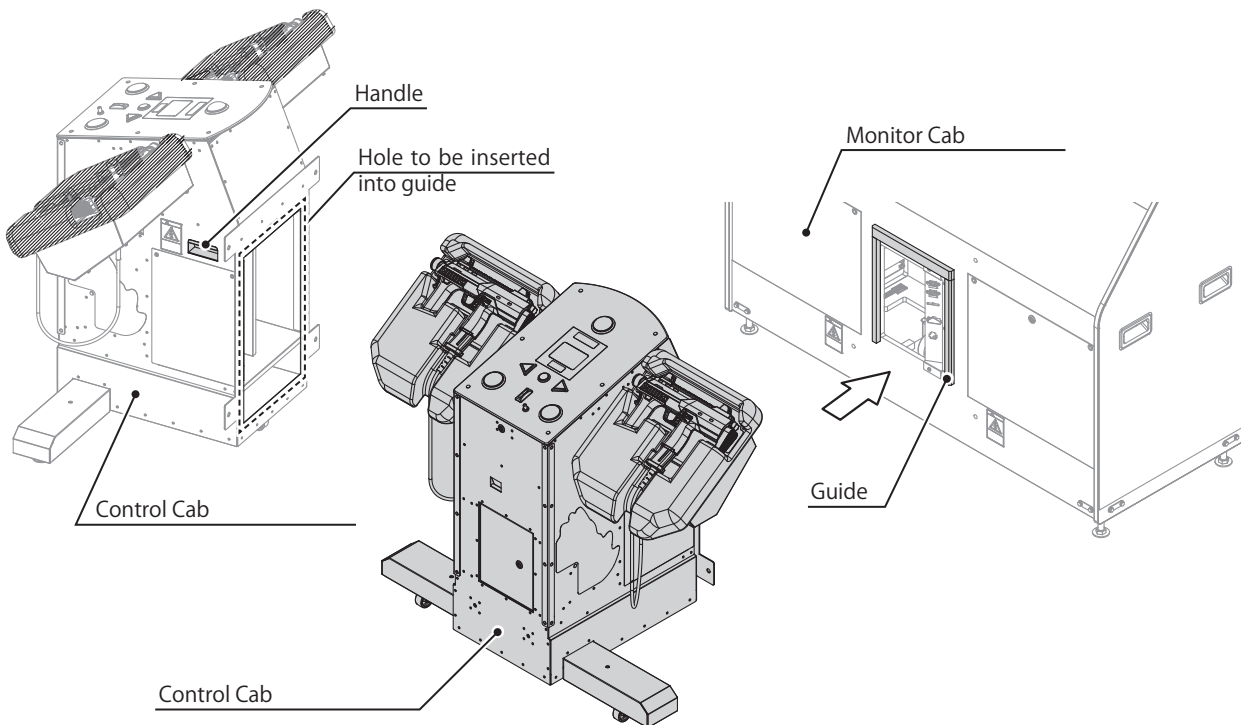

3 Fix the Control Cabinet with 4 hex bolts.

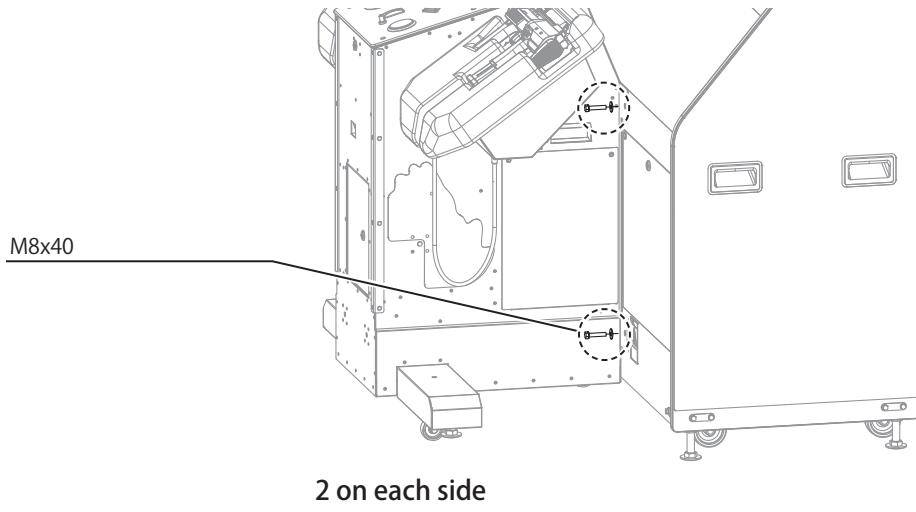

4 Remove the 2 screws and remove the Side Lid.

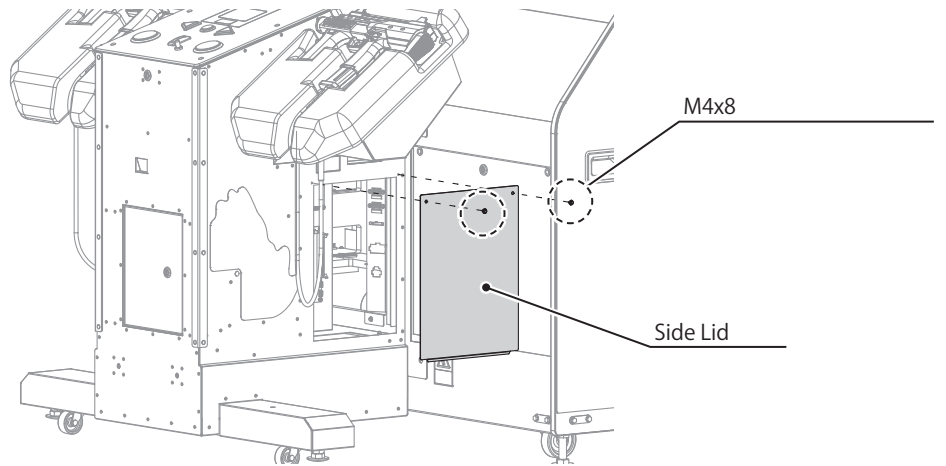

5 Connect five connectors.

Connector
USB[USB1]

Connector
USB[USB3]

Connector
SM11P

Connector
YL21P

Connector
YL9P



6 Attach the Side Lid with 2 screws.

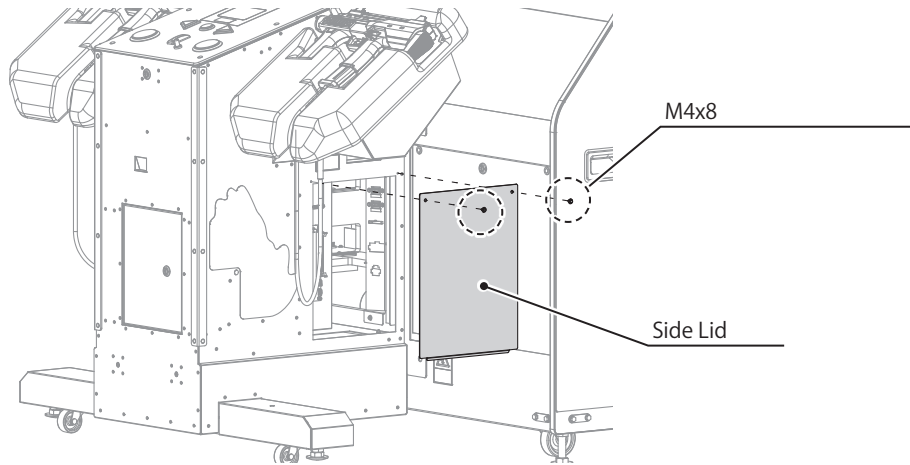

7 Remove the 2 screws and remove the Back Lid.

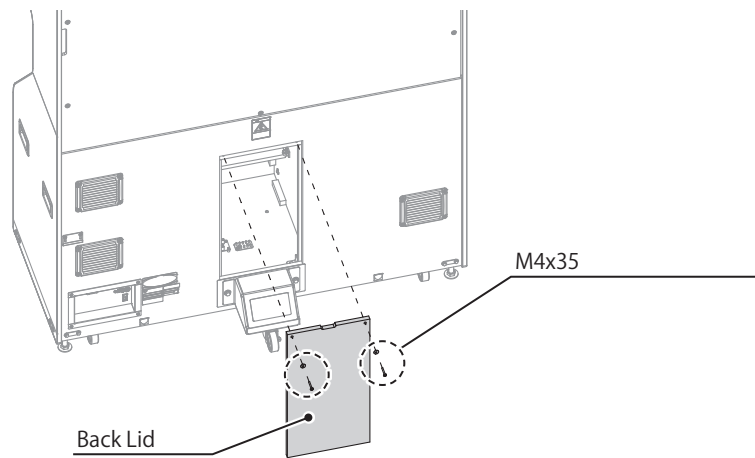

CAUTION

After installing the cabinet, please remove the support bracket.

When dividing and moving the cabinet, attach the support bracket. Failure to do so may cause the case the cabinet to fall or topple over causing injury.

8 Remove 2 hex bolts and remove Support Bracket.

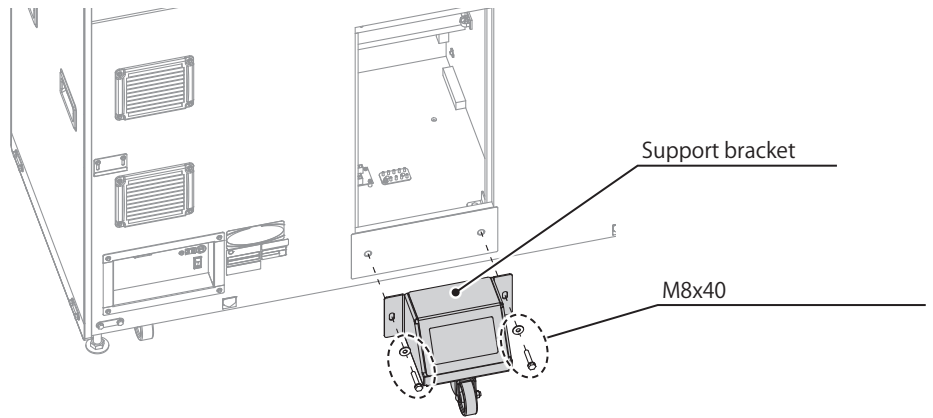

9 Attach the Support Bracket inside the Cabinet with 2 hex bolts.

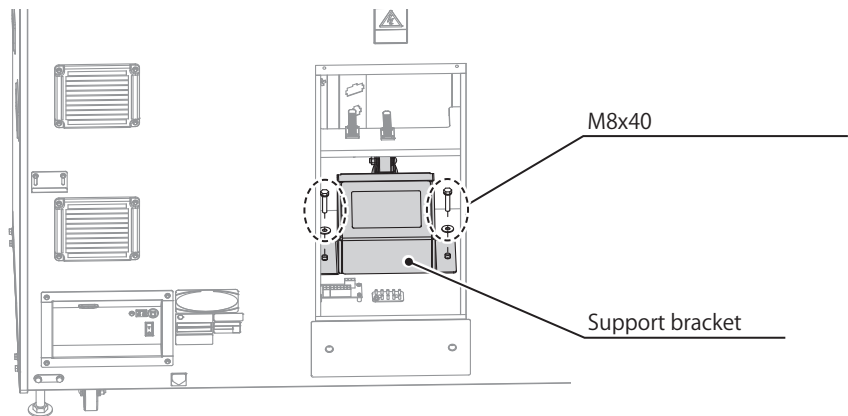

10 Attach the Back Lid with 2 screws.

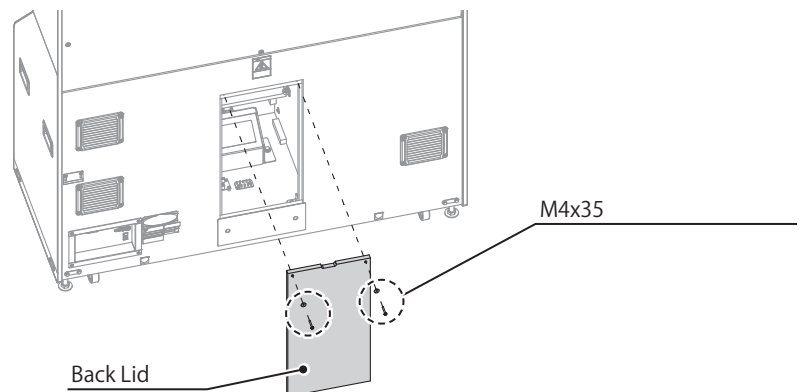

6-2 STEP INSTALLATION

Carry out this operation with 2 or more people.

- 1 Ensure the four adjusters on the bottom of the Seat Cabinet are touching the floor.

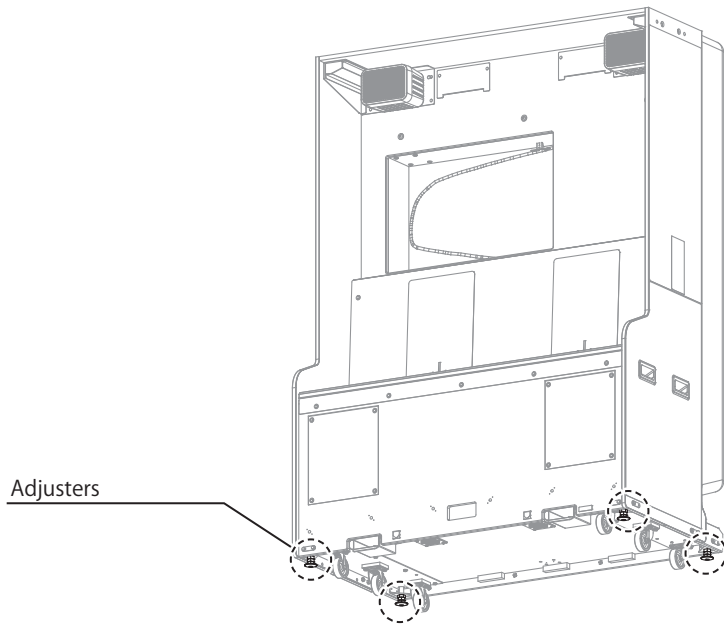

- 2 Remove 10 truss screws and remove the Floorboard from the Step.

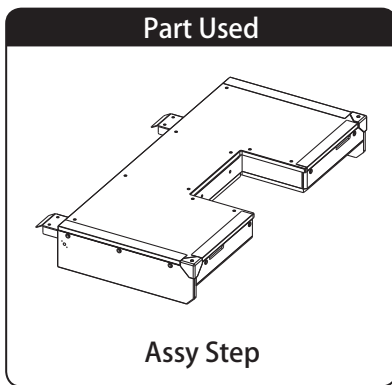

M4x30

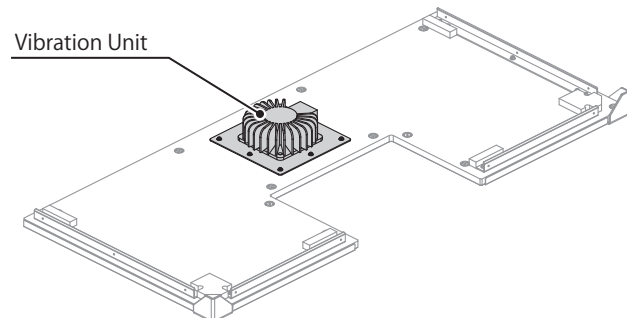
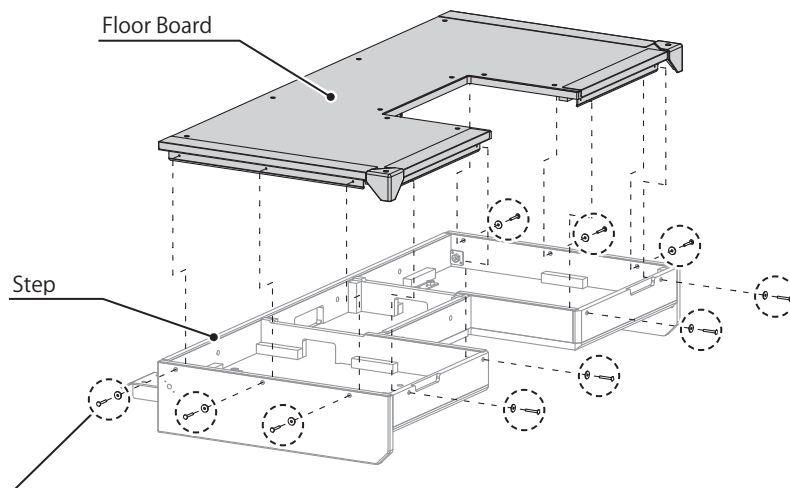

3 Remove 8 tamper proof screws and remove the 2 Seat Doors.

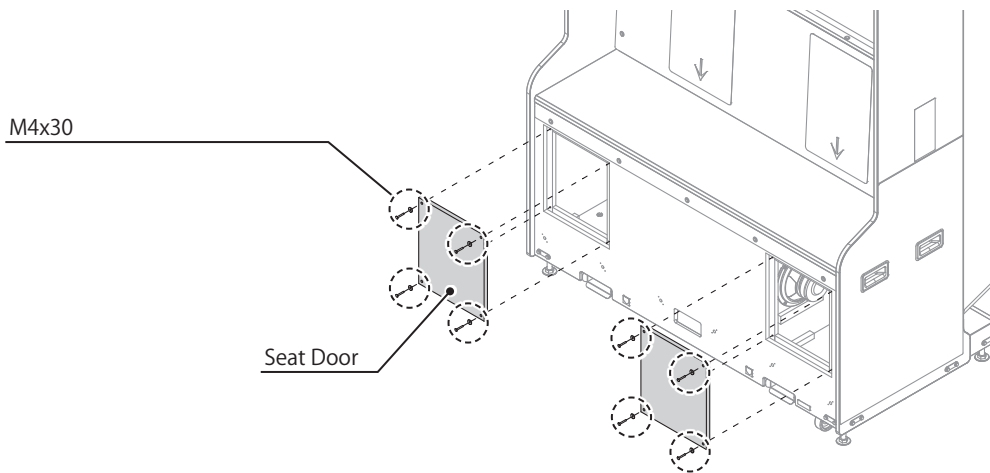

4 At least two people support the Step and plug into the Seat Cabinet. Align and position so that the joint bridge of the Step enters the socket of the Seat Cabinet.

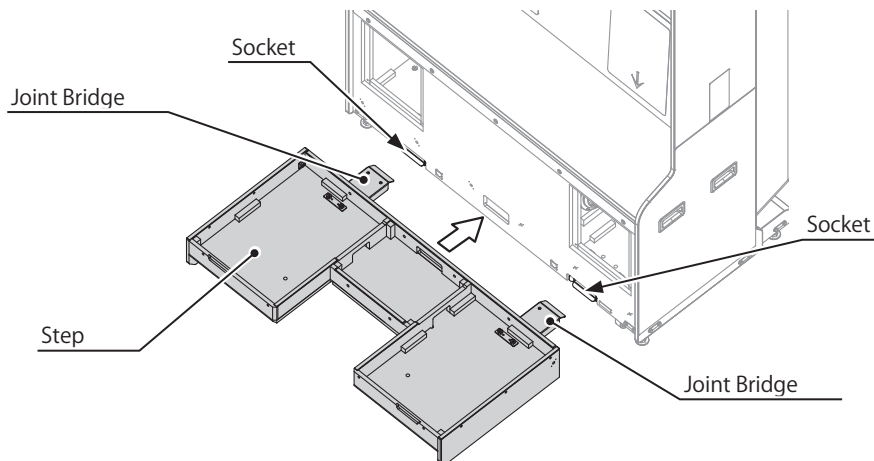

5 Fix the Step with 4 hex bolts.

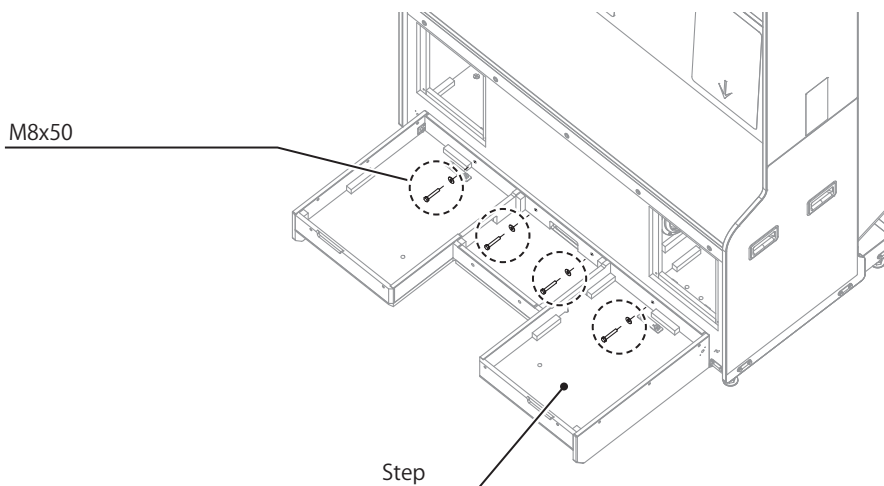

6 Fix the Step with 4 hex bolts.

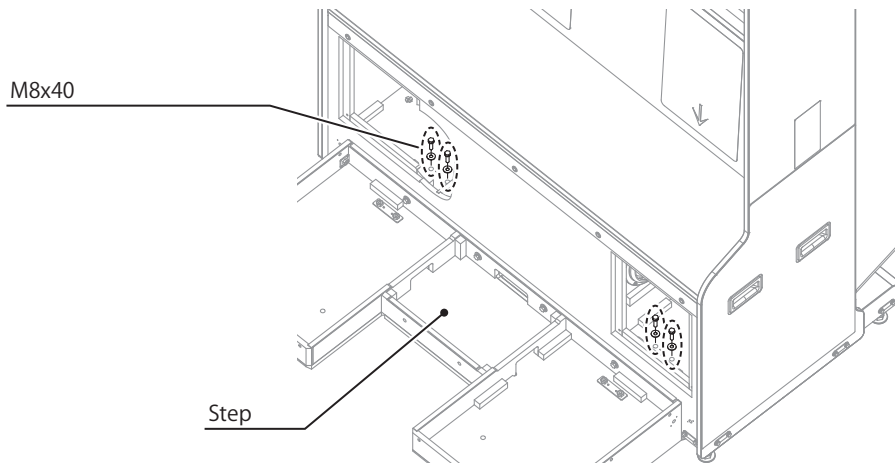

7 Attach two Joint Brackets with 4 hex bolts.

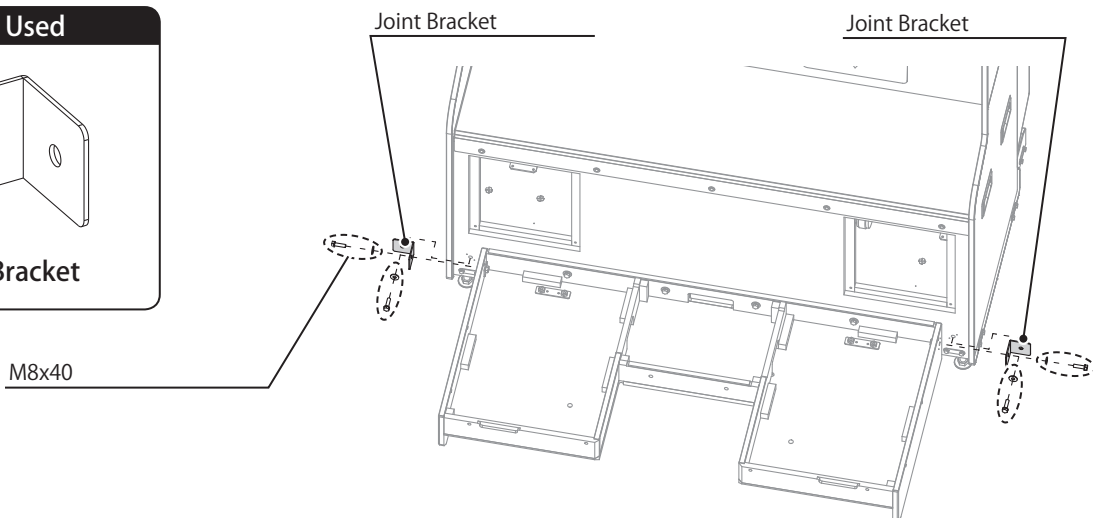
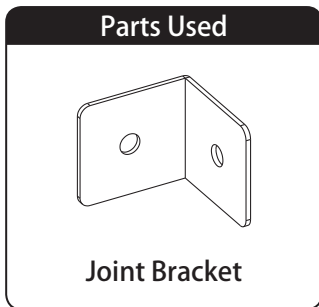

8 Attach two Seat Doors with 8 tamper proof screws.

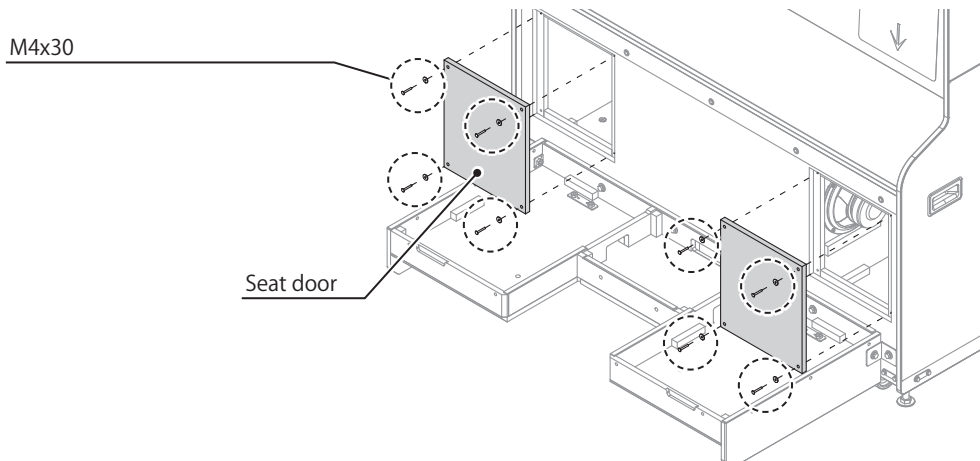

6-3 MOUNTING THE SEAT CABINET

Carry out this operation with 2 or more people.

- 1 Raise the four adjusters on the bottom of the Seat Cabinet and ensure casters touch the floor.

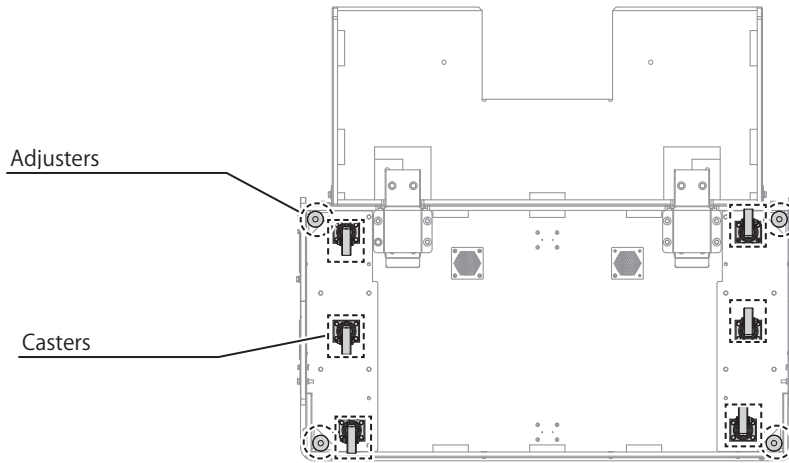

- 2 Support the Seat Cabinet with two or more people and insert it into the Control Cabinet. Place the Step on the leg of the Control Cabinet at this time.

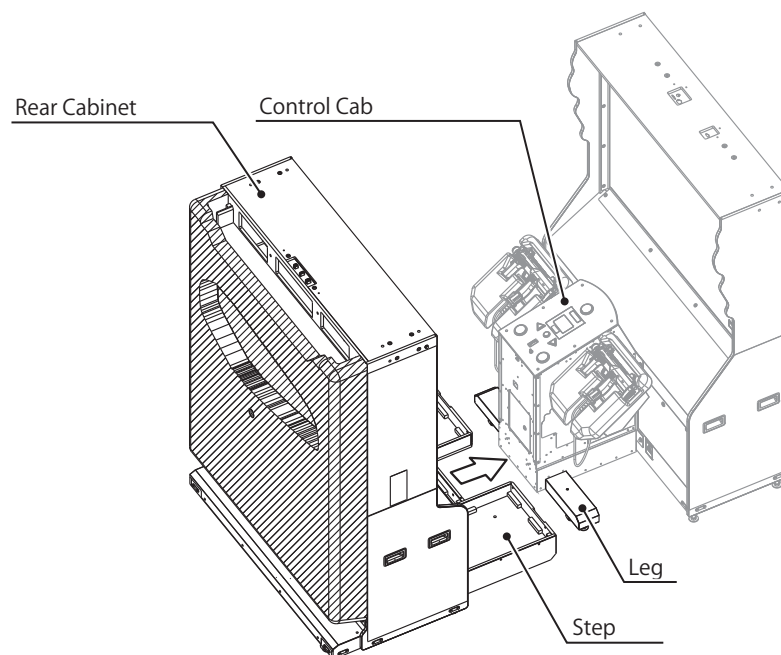

3 Fix the Step with 2 hex bolts.

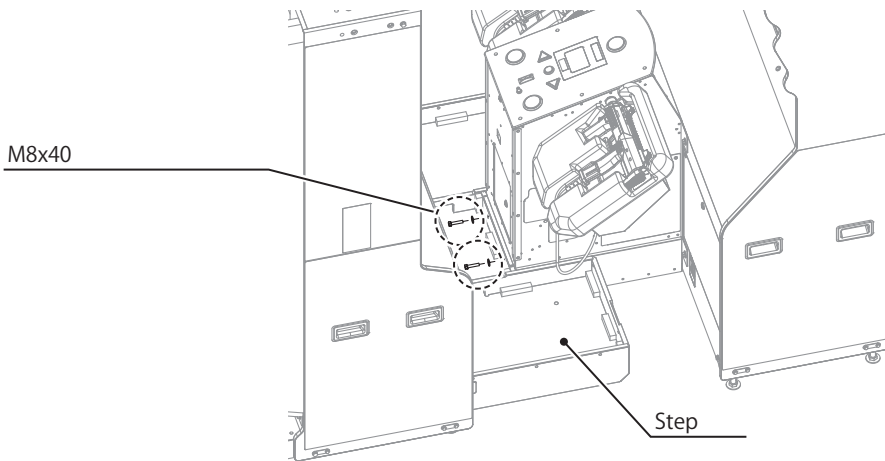

4 Fix the Step with 2 hex bolts.

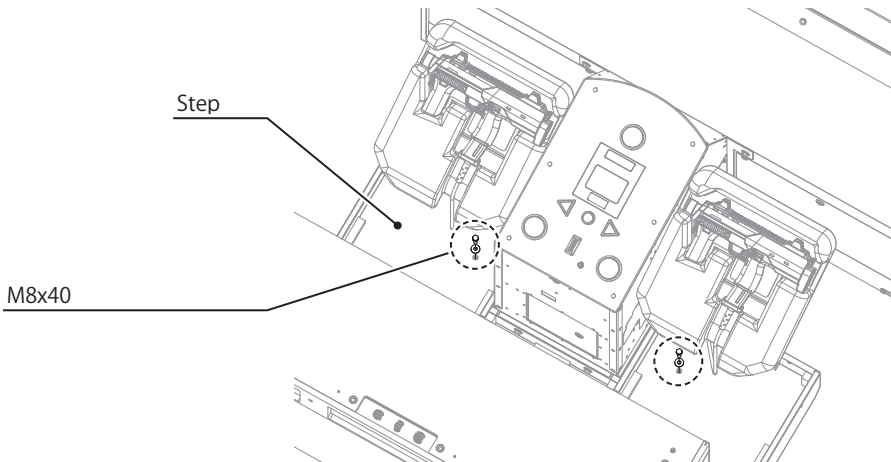

5 Place the Floorboard on the Step. One person should continue supporting the Floorboard until step 8.

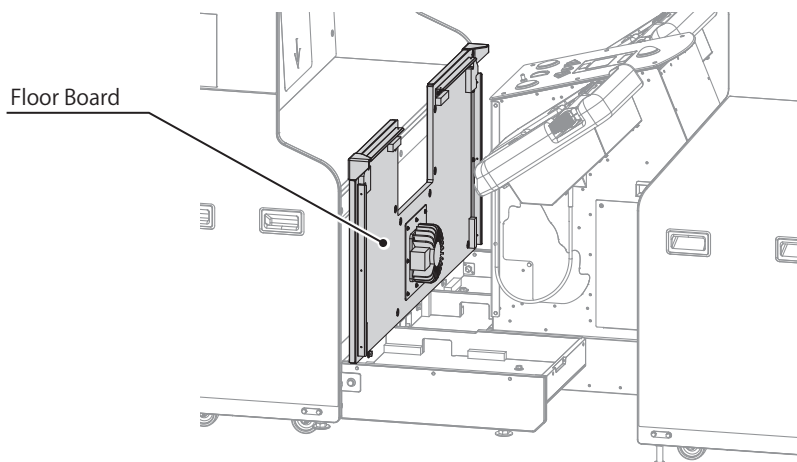

6 Access one connector from the Step hole.

Connector
YL2P

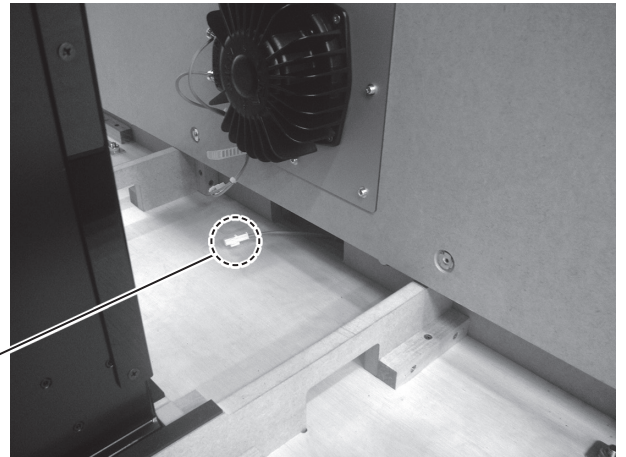

7 Connect one connector.

Connector
YL2P

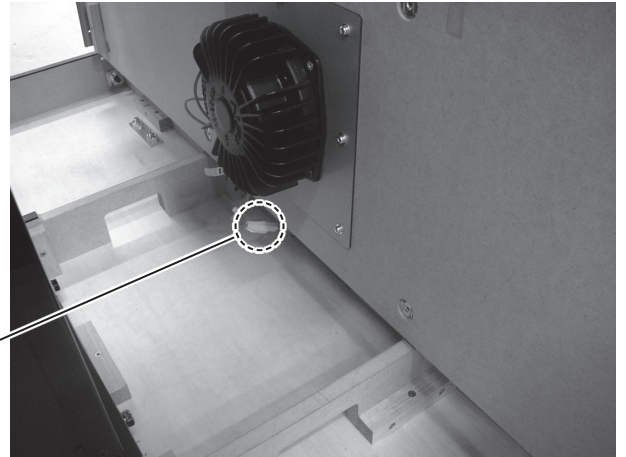

8 Support and close the Floorboard with two or more people. Take care not to damage the Controller Holder and Controller Cable at this time.

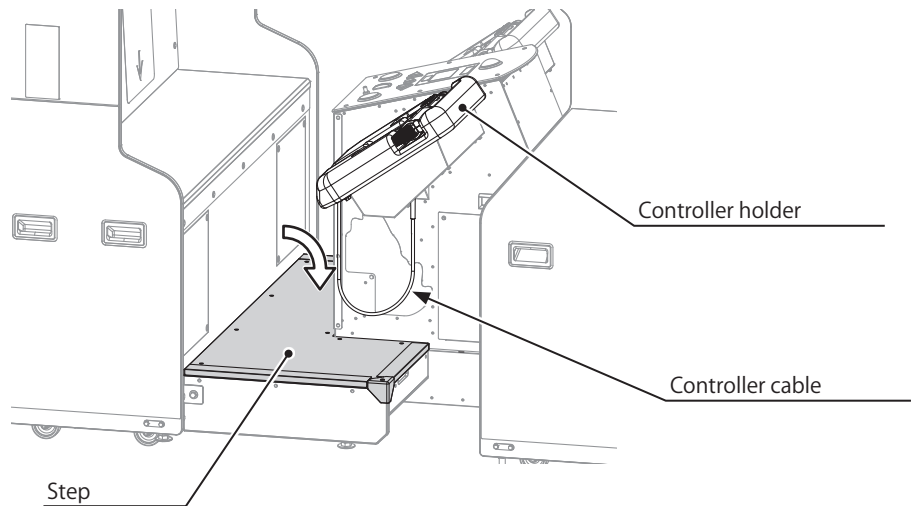

9 Fix the Floorboard with 10 truss screws.

Step

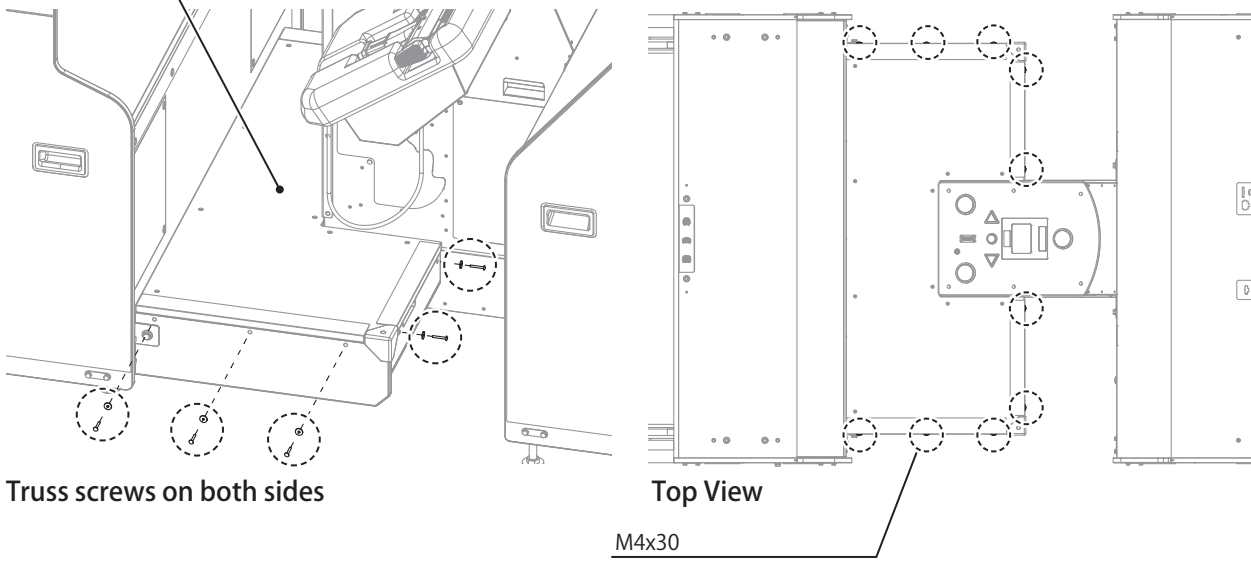

10 With ten tamper proof screws, attach the Sash Center, Sash Side (x2), and Rear Sash.

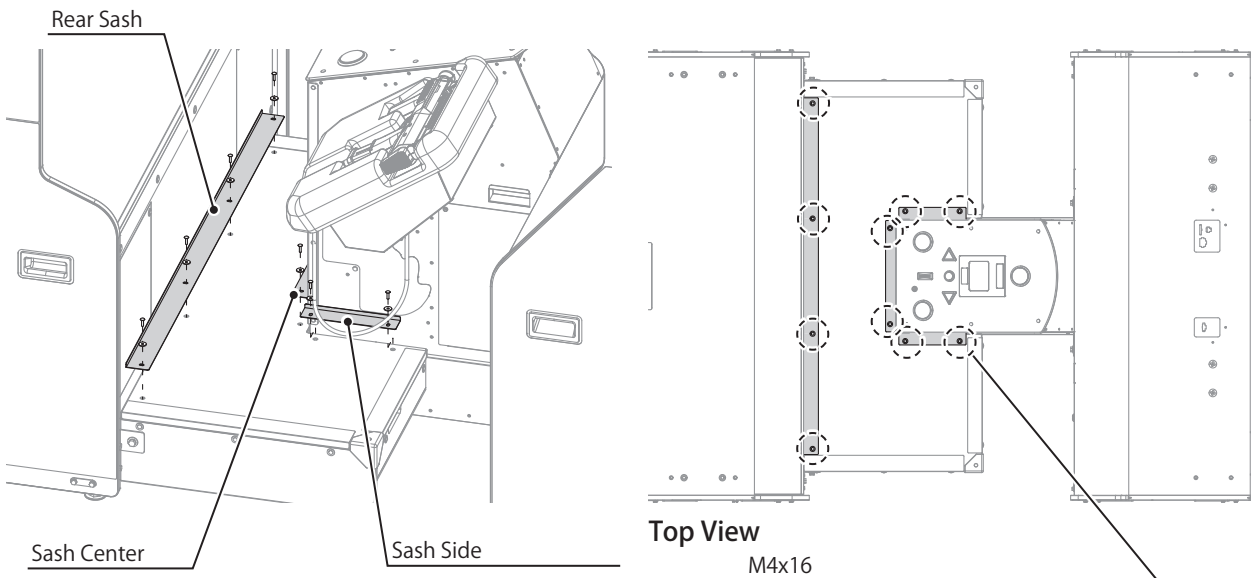
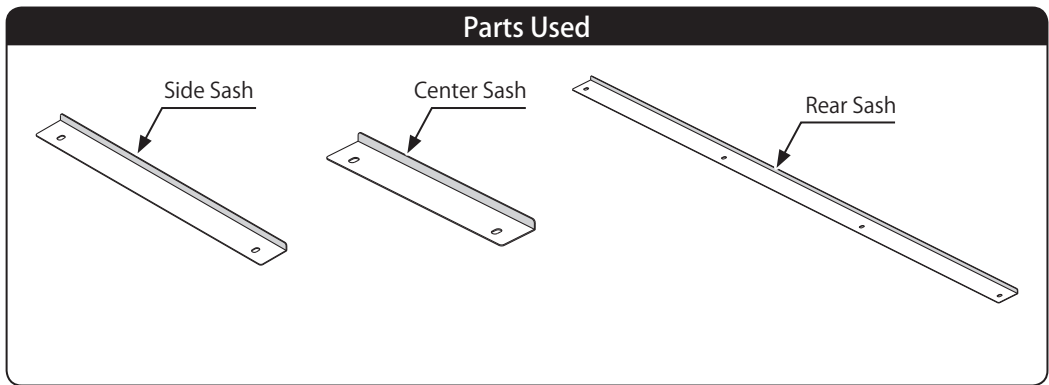

6-4 ATTACHMENT OF JOINT FRAMES

Carry out this operation with 2 or more people.

- 1 Ensure the four adjusters on the bottom of the Seat Cabinet are touching the floor.

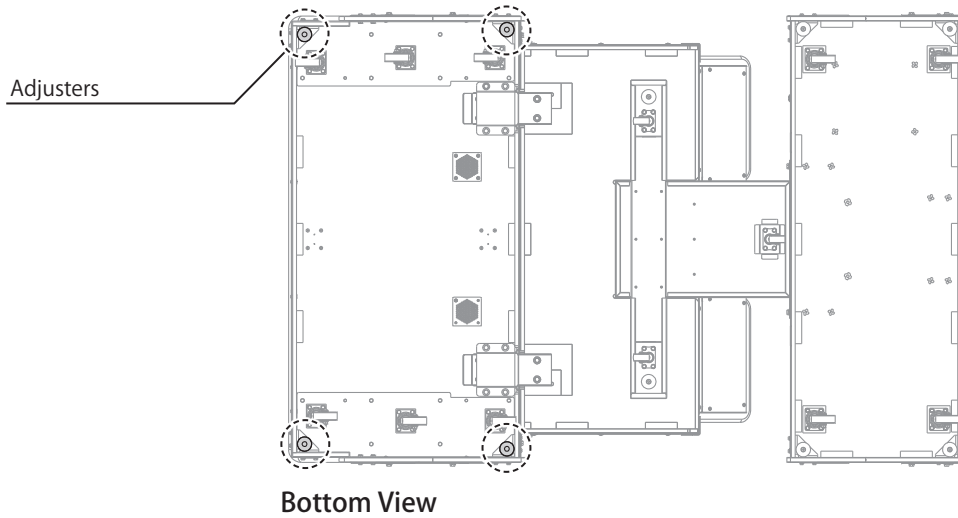

- 2 At least two people support the Joint Frame L and place it on both the Monitor Cabinet and Seat Cabinet in the orientation shown.

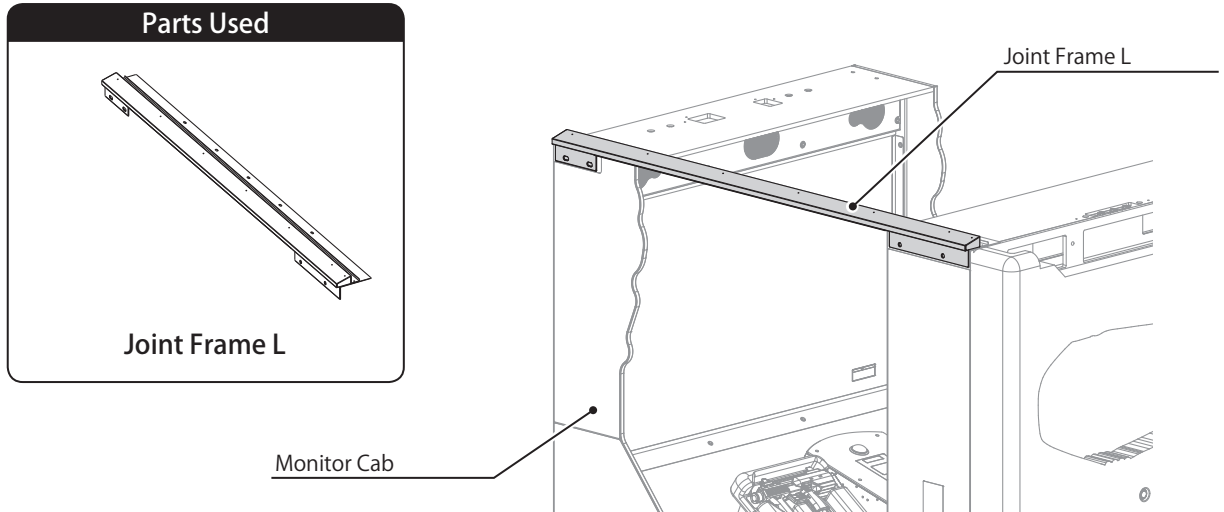

3 Temporarily fix the Joint Frame L to the Seat Cabinet with 4 hex bolts.

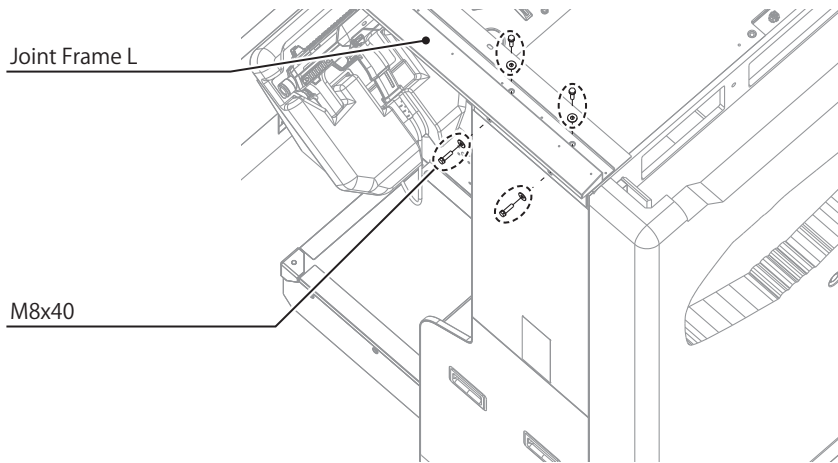

4 Temporarily fix the Joint Frame L to the Monitor Cabinet with 4 hex bolts.
If the hole positions do not match, adjust the height with the adjusters on the Seat Cabinet.

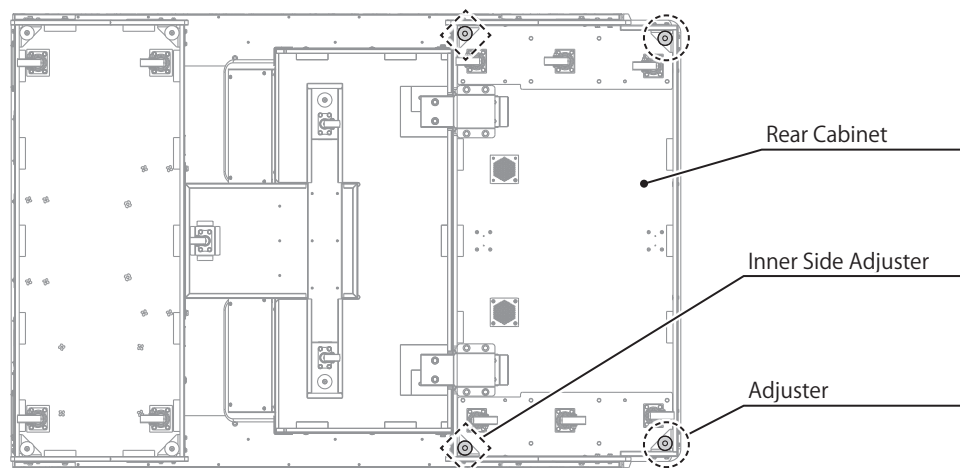
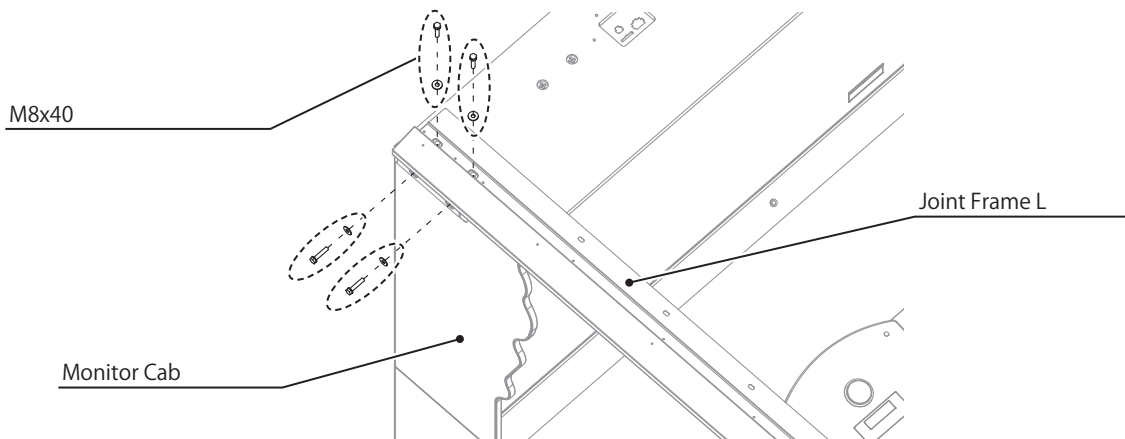

Bottom View

5 Perform the same procedure on the opposite side to fit the Joint Frame R. Fully tighten the fixings of both brackets once both are in place.

6-5 ASSEMBLING THE ROOF

in most cases, the Roof Assembly will come fitted to the cab and will not require assembly or fitting. However, in the case it does not, please follow the proceeding instructions.

- 1 Remove the 10 screws and remove the Roof Box Lid from the Roof Box.

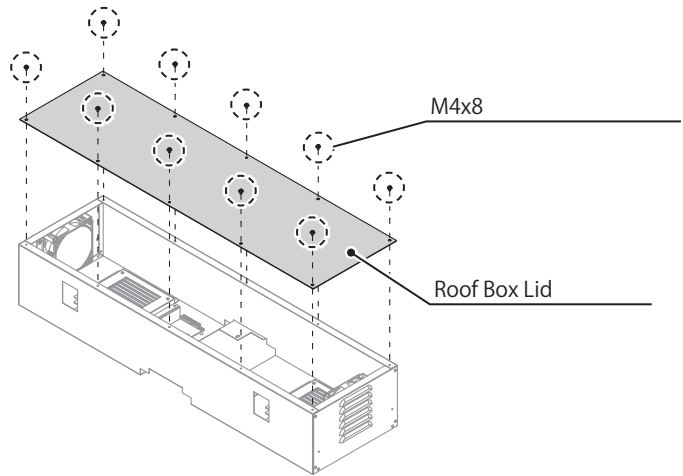
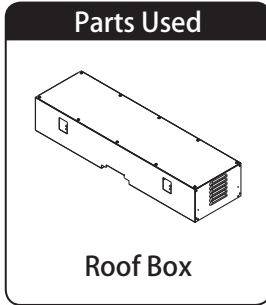

- 2 Attach the Roof Box to the Roof Base with 2 screws. The Roof Box must be in the orientation shown. Attach the Roof Box to the Roof Base with 2 screws. At this time, ensure that the rectangular hole is on the board side.

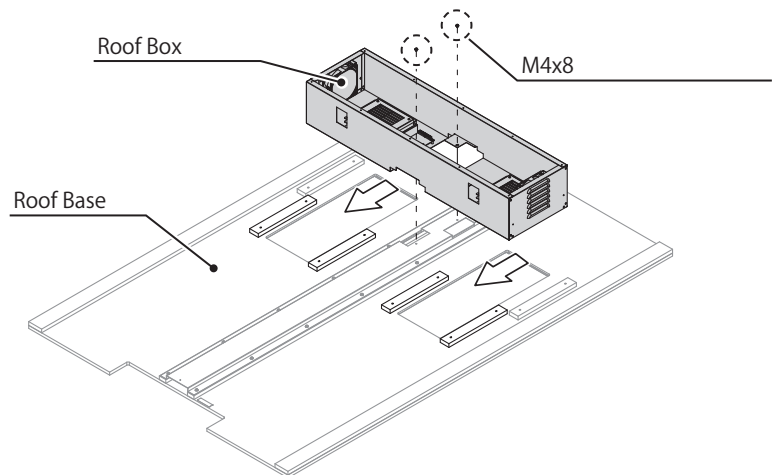
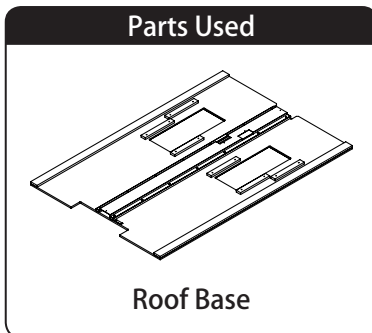

- 3 Attach two Roof Box Brackets with 8 screws.

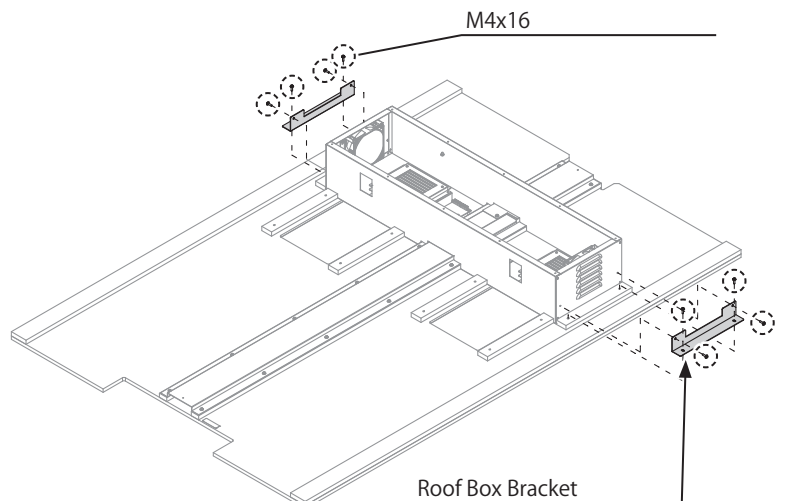
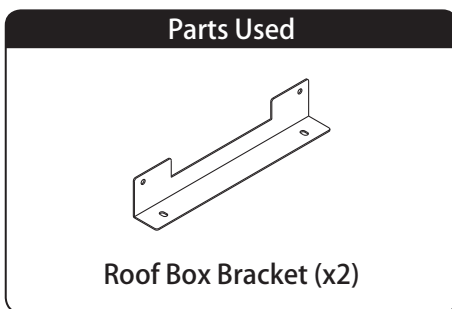

4 Connect four connectors. Insert the Ground Terminal into the stud.

Connectors
VH5P、SM5P、YL2P、YL9P

Ground Terminal

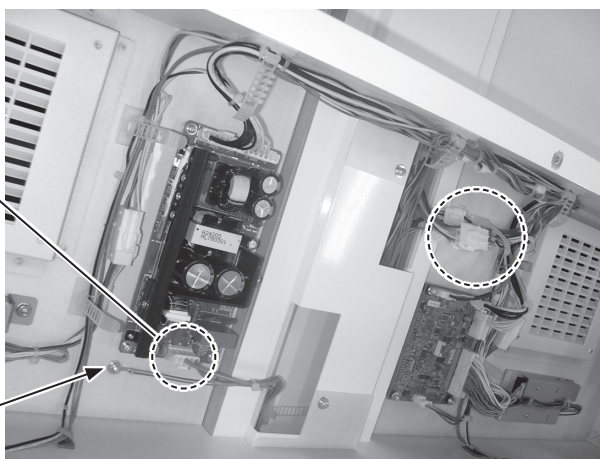

5 Fix the Ground Wire.

M4 Nut

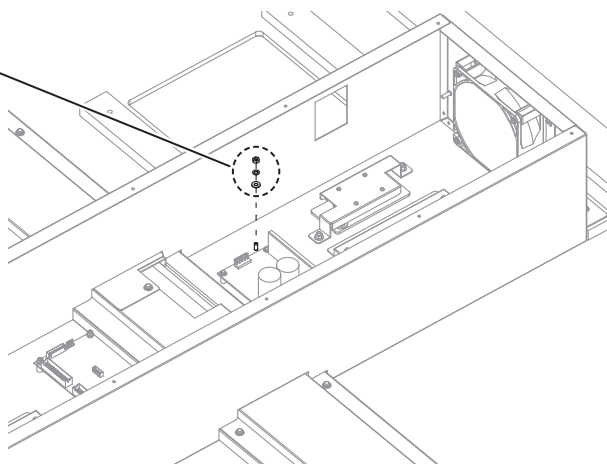

6 Place the Air Gimmick Box on the Roof Base.

Parts Used

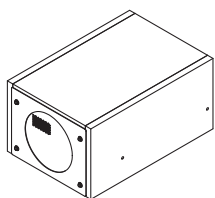

Air Gimmick Box

Air Gimmick Box

Roof Base

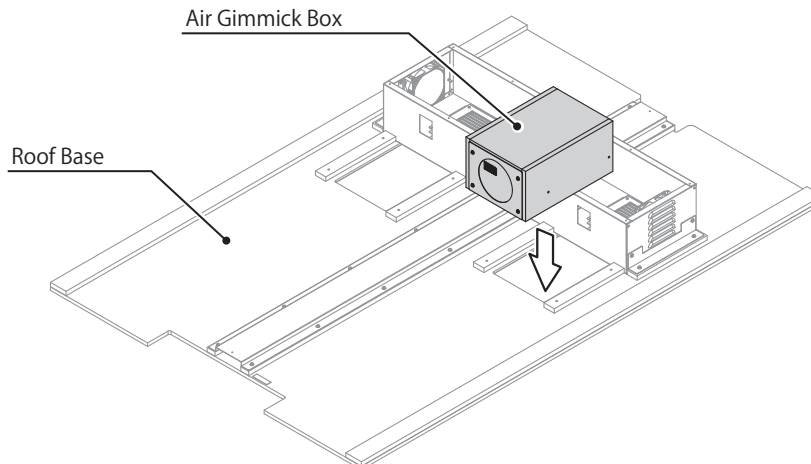

7 Install two Roof Box Brackets with 8 screws.

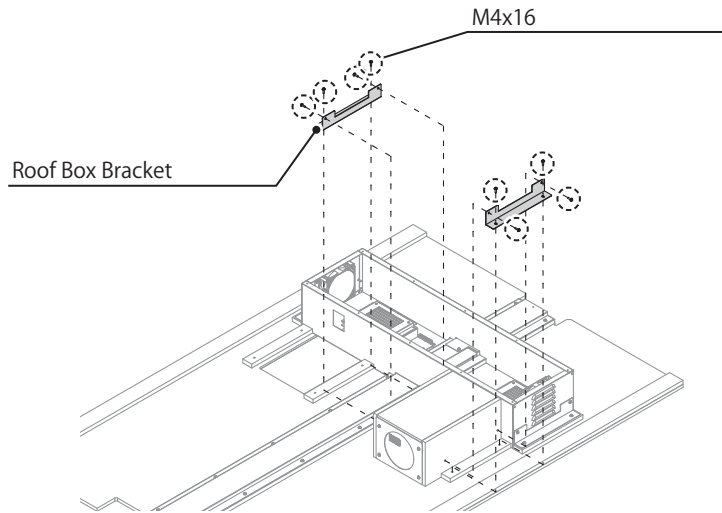
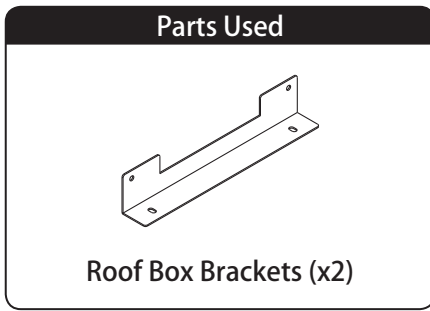

8 Connect one of the roof box connectors.

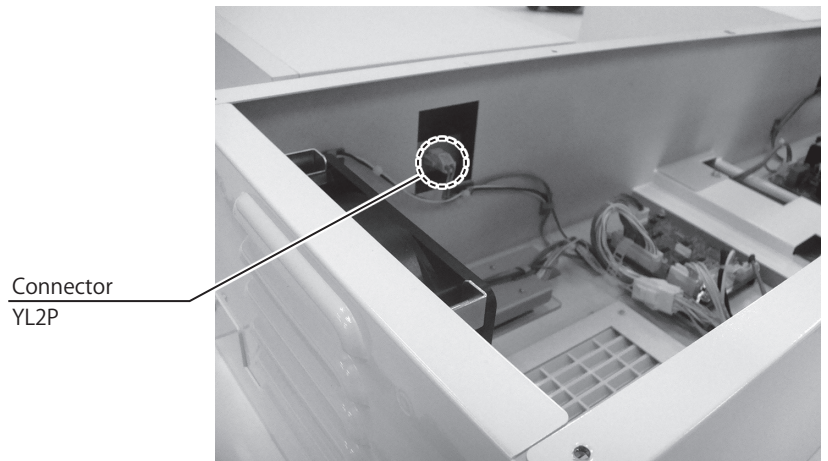

9 Refer to steps 6 to 8 and install the Air Gimmick Box on the opposite side.

10 Attach the Roof Box Lid with 10 screws.

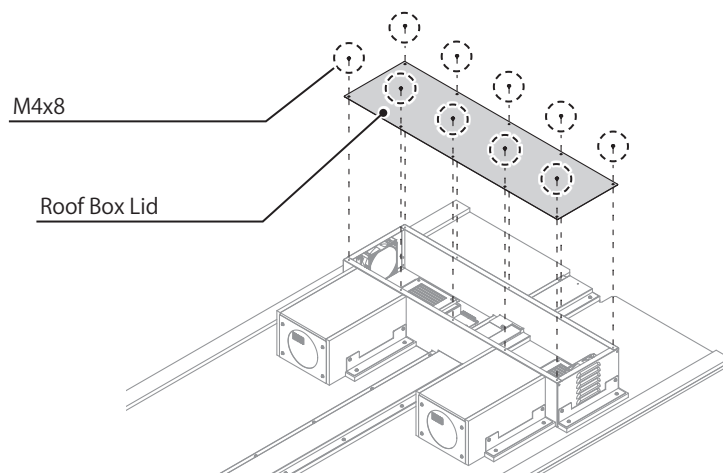

6-6 ATTACHING THE ROOF

Carry out this operation with 4 or more people.

1 Support the Roof assembled in "6-5" with 4 or more people and place it on Joint Frame L & R. Pay attention to the following items:

- ① Please confirm the position so that the Roof Box is on the side of the Seat Cabinet.
- ② Please put it from the side against the cabinet.
- ③ Place the roof once on the Joint Frame.
- ④ Two people move on top of the step. Please place it while sending the roof.
- ⑤ Please put the guide of the roof between the Joint Frame.
- ⑥ Please move so that the guide of the Roof hits the Seat Cabinet.

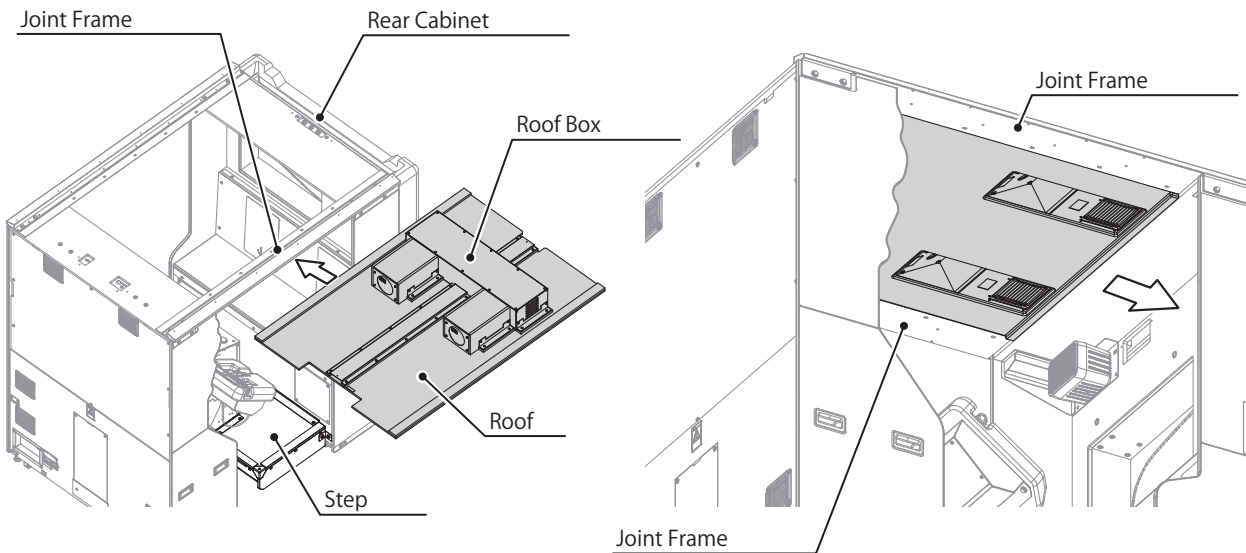

2 Fix the Roof with 10 truss screws.

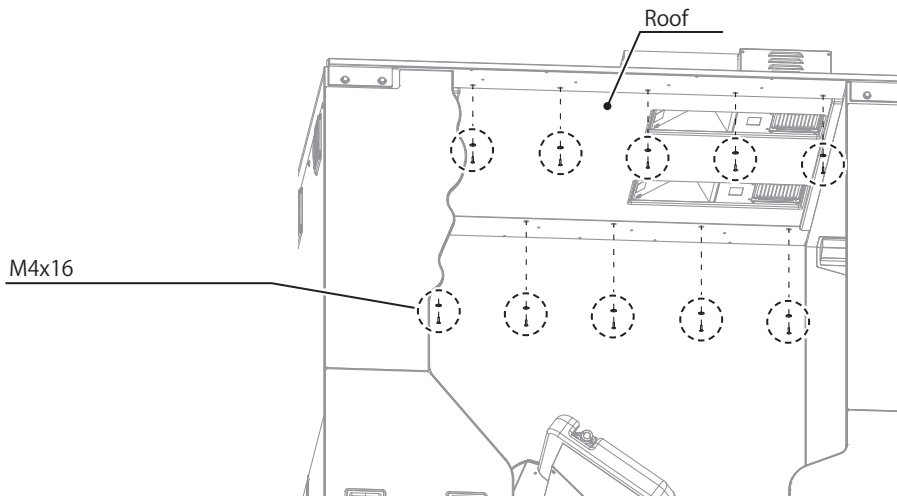

3 Connect the wiring from the Roof Beam using the three connectors.

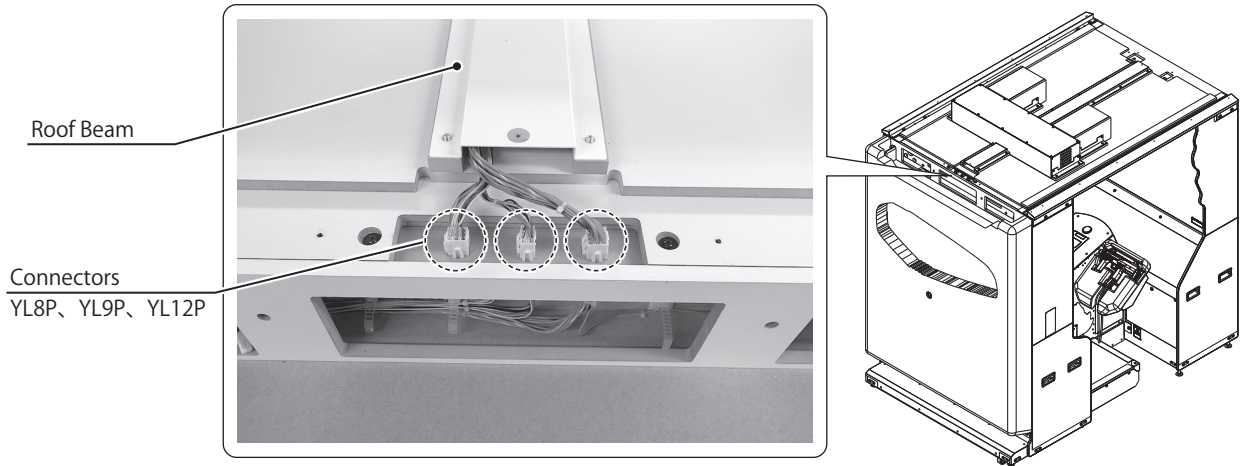

4 Attach the Connector Lid Seat with 3 screws.

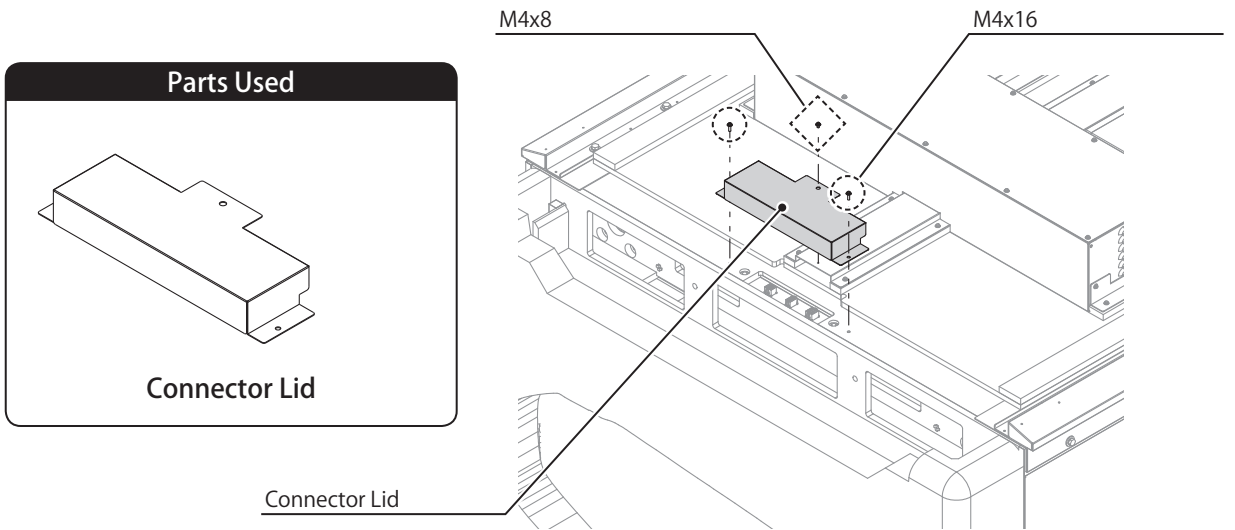

5 Connect the wiring from the Roof Beam using three connectors.

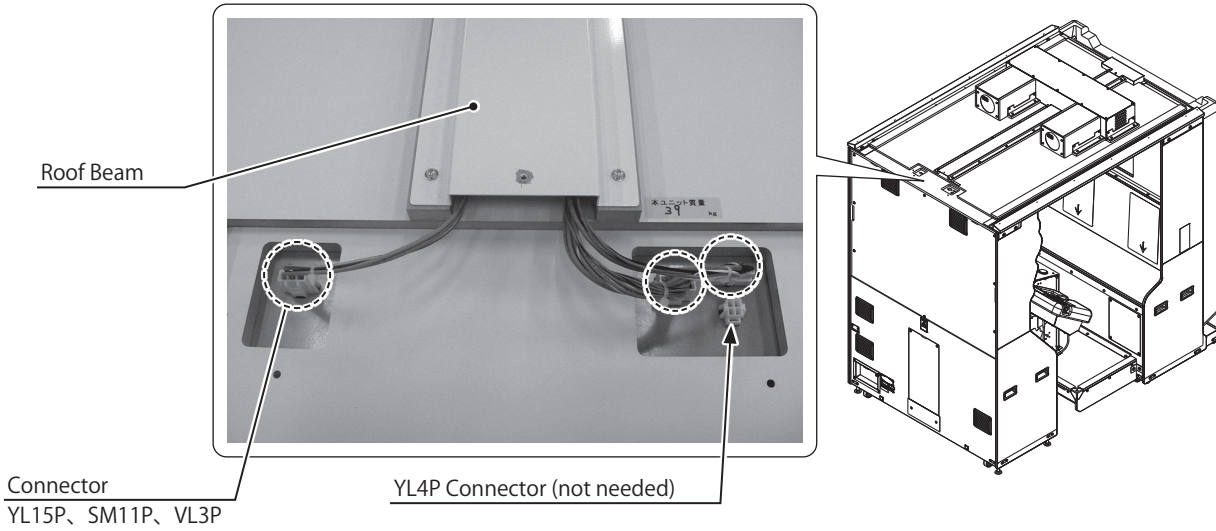

6 Attach the Connector Lid Monitor with 5 screws.

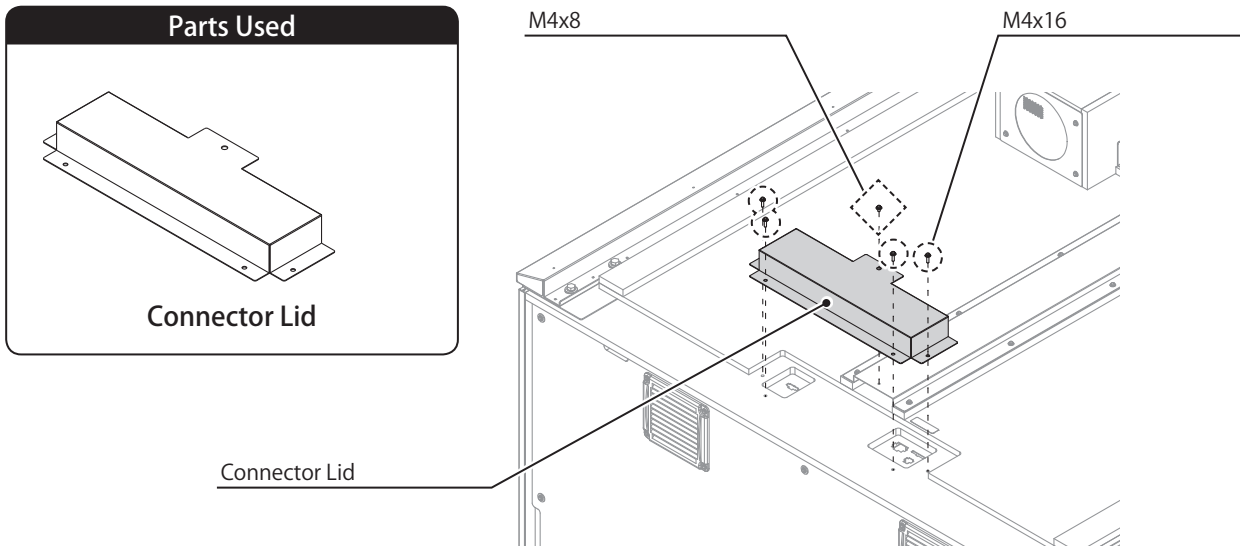

6-7 INSTALLATION OF BILLBOARD

Carry out this operation with 2 or more people.

- 1 Remove 4 truss screws and remove 2 Billboard Lid.

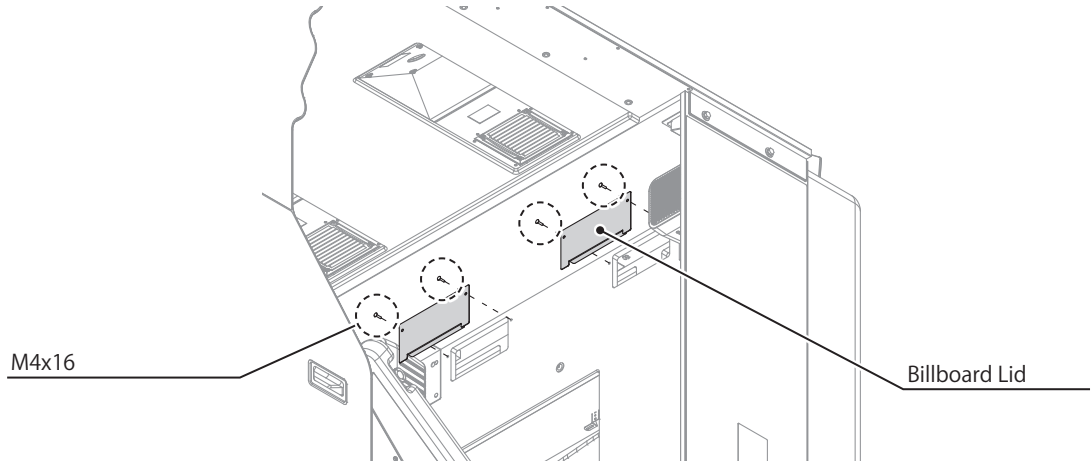

- 2 Insert the Billboard Plate into the Billboard Box and secure with two truss screws.

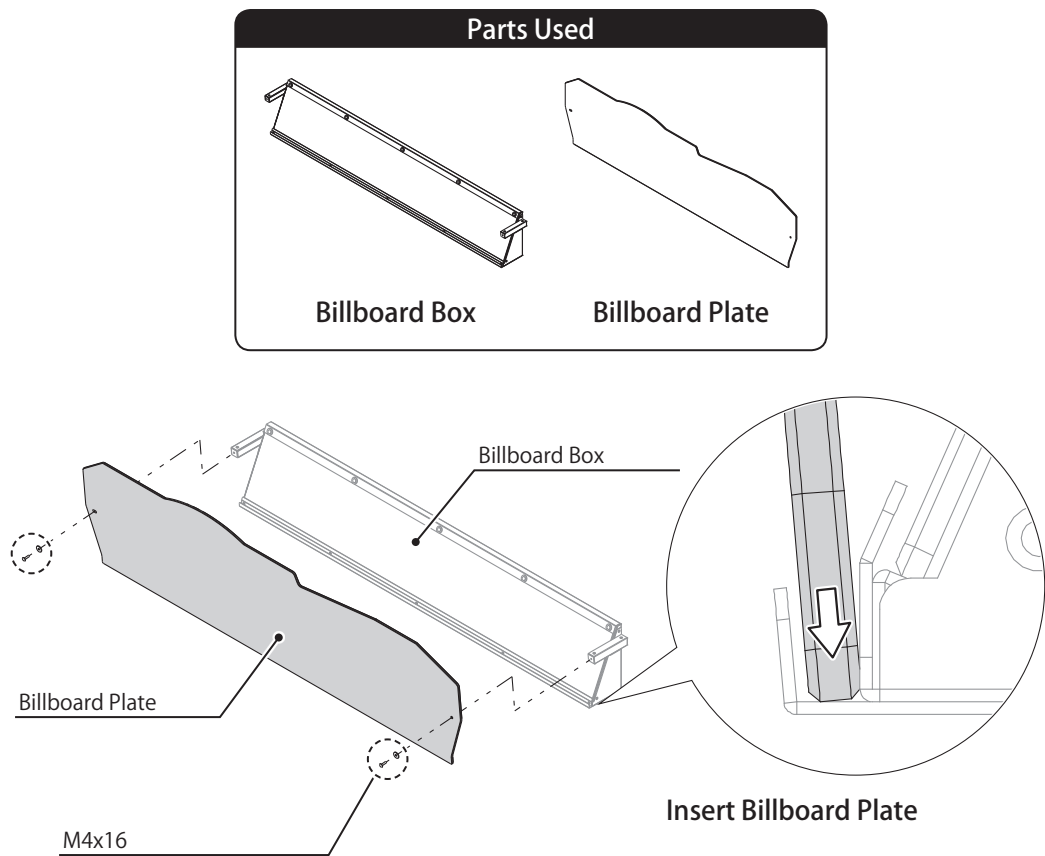

3 Temporarily fasten 4 screws to the back of the Billboard Box.

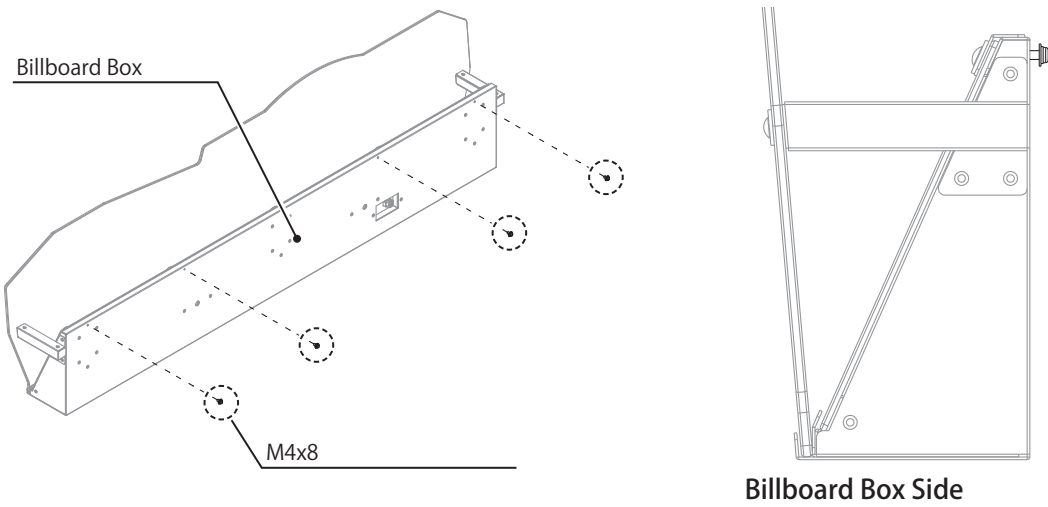

4 At least two people support the Billboard Box and place it on the Seat Cabinet. Place from the top so that it enters the guide of the Seat Cabinet. Take care not to scratch the Rear Cover and Billboard Plate at this time.

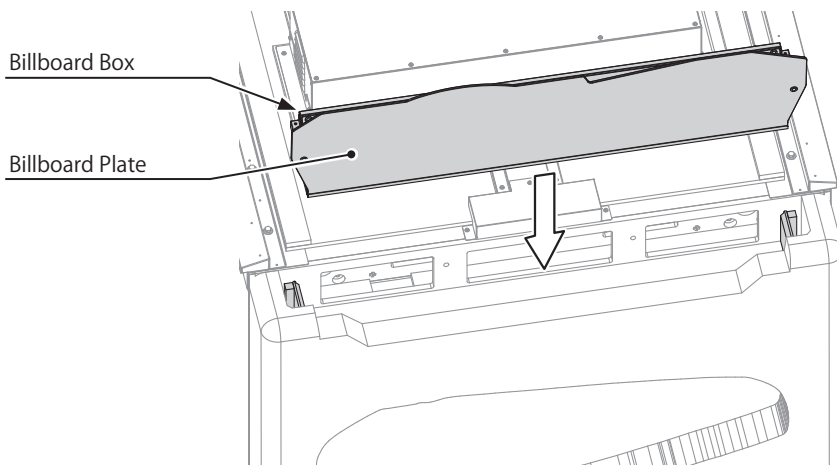

5 Secure the Billboard Box with 2 hex bolts.

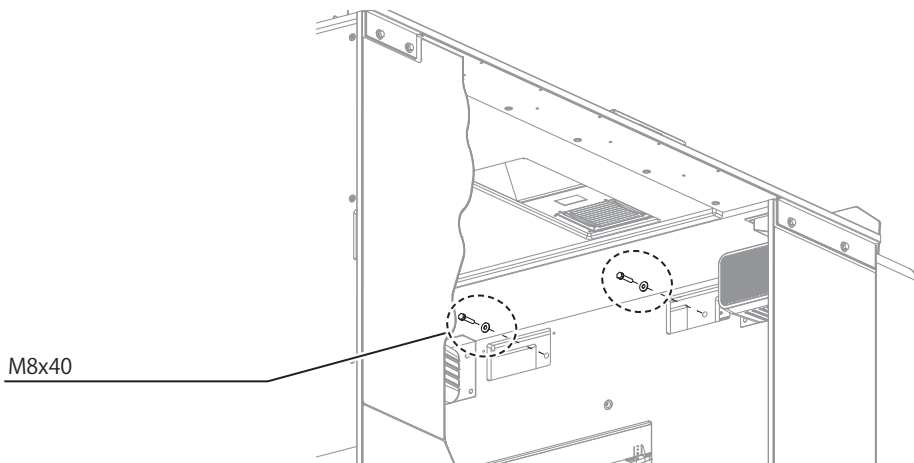

6 Connect one connector.

Connector
YL4P

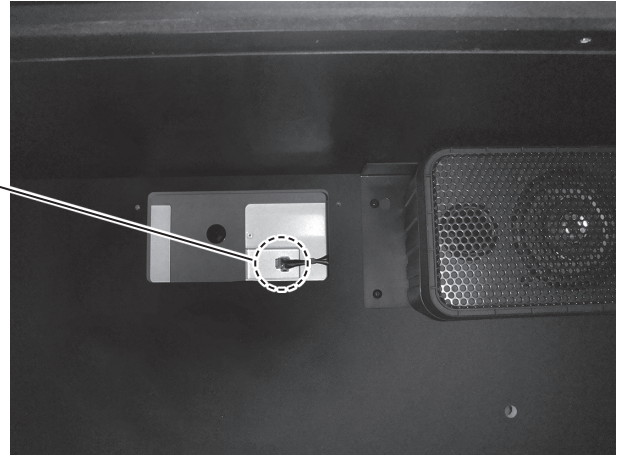

7 Attach 2 Billboard Lids with 4 truss screws.

M4x16

Billboard Lid

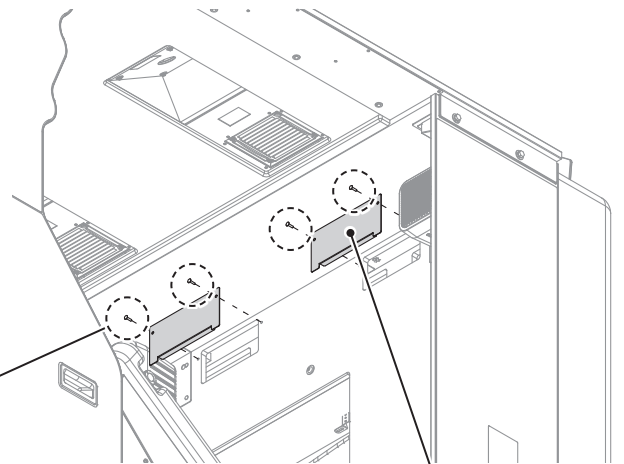

6-8 POP PANEL INSTALLATION

Carry out this operation with 2 or more people.

- 1 Support Pop Panel with two or more people and plug it into the screw temporarily fixed to the Billboard Box.

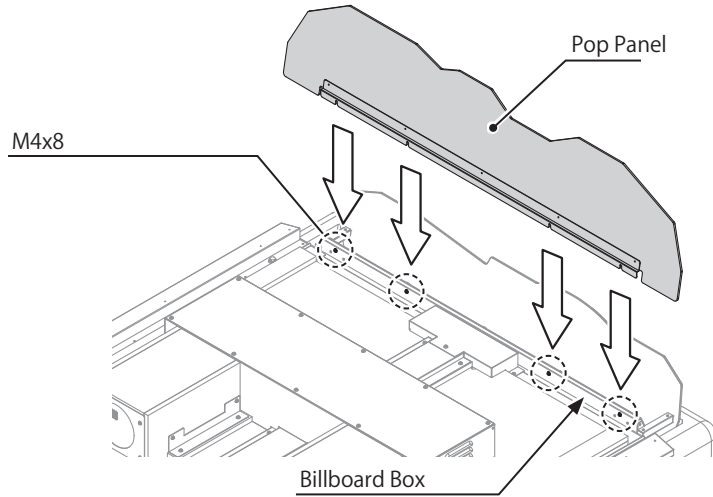
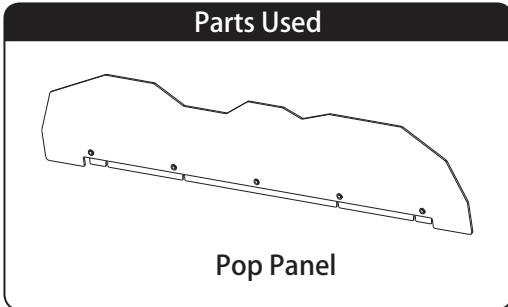

- 2 Fully tighten the four screws used in step 1.

6-9 APPLYING CURTAIN

Carry out this operation with 2 or more people.

- 1 Temporarily fasten six truss screws to the Joint Frame L.

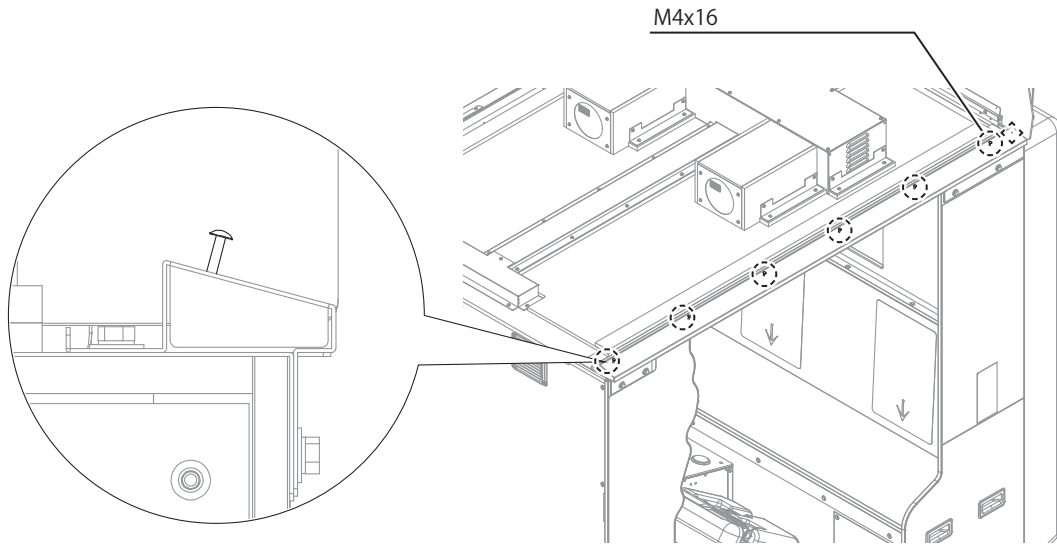

- 2 Hook the Side Curtain to the temporarily fixed truss screw.

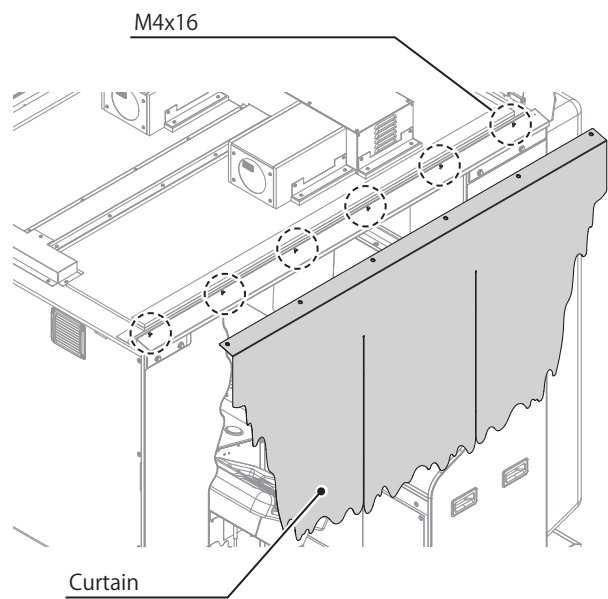
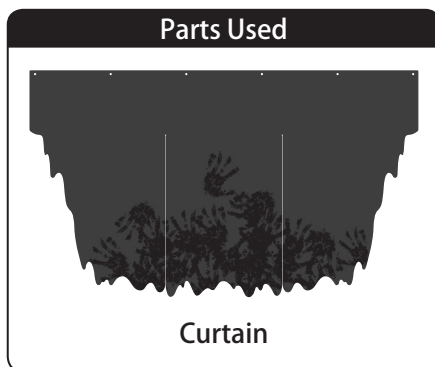

3 Hook the Sub Curtain L to the temporarily fixed truss screw.

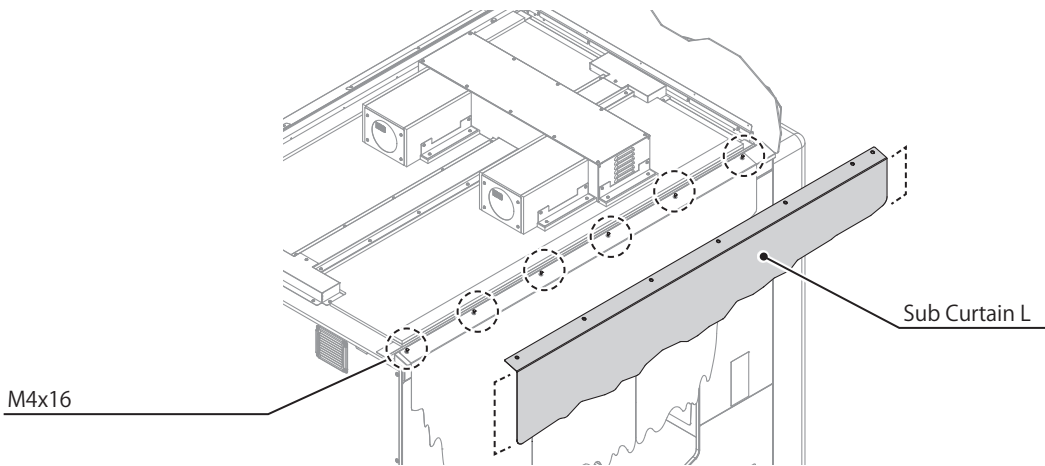
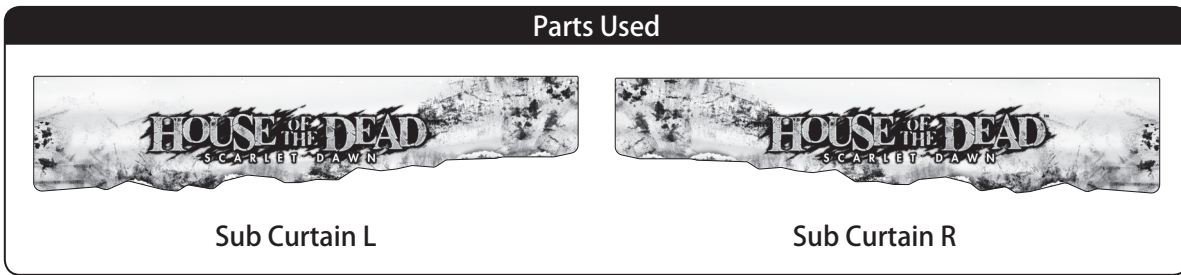

4 Hook the two Curtain Sashes onto the temporarily fixed truss screw and fully tighten 6 truss screws. At this time, please make sure cutout of Curtain Sash faces outward.

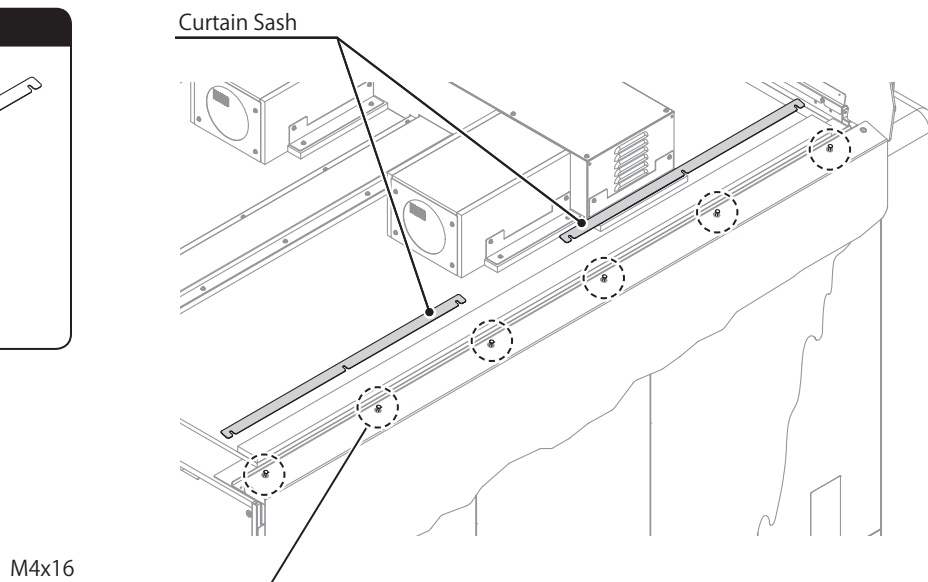
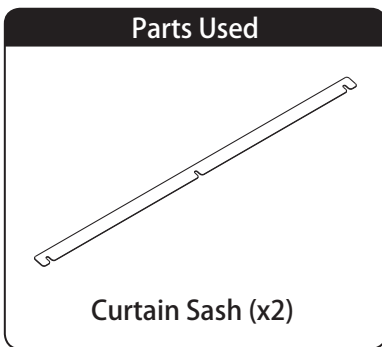

5 Secure the Sub Curtain L with one truss screw.

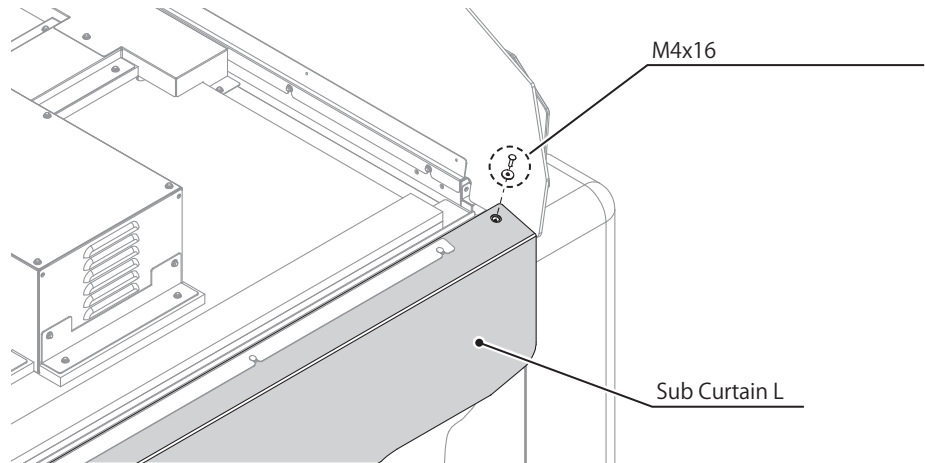

6 Refer to steps 1 to 5 and attach remaining Curtain on the opposite side.

6-10 FIXATION TO INSTALLATION PLACE

This product has 13 casters and 10 adjusters.

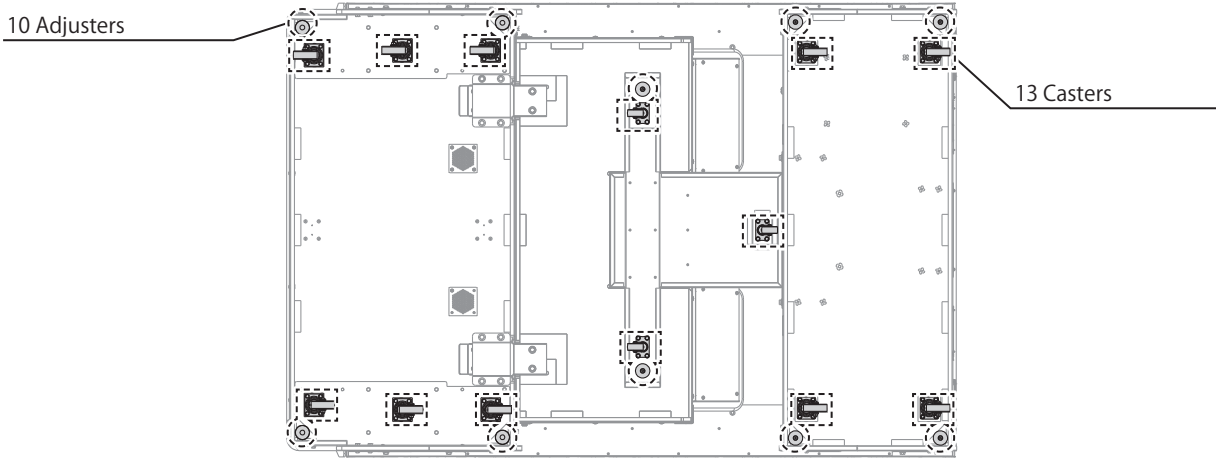

1 Raise all the adjusters and let the casters contact the floor.

2 Move the cabinet to the installation location

3 Make sure all adjusters contact the floor and adjust the height of the adjuster so that the cabinet is level. Please adjust to keep level by leaving about 5 mm gap between the floor and the caster.

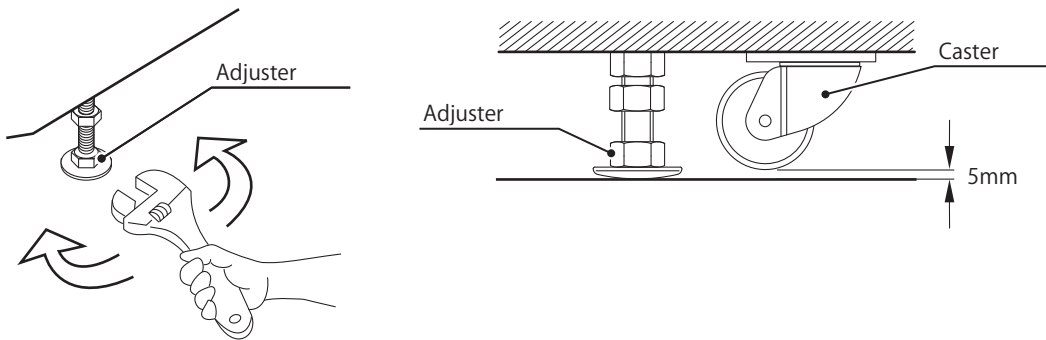

4 After adjustment, tighten the nut of the adjuster upward and fix the height of the adjuster.

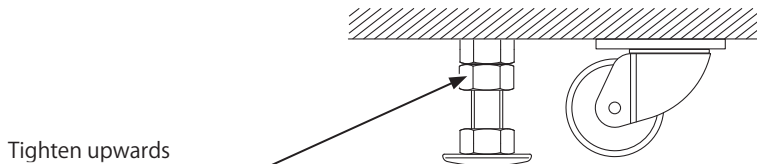

6-11 INSERTING KEY CHIP

STOP IMPORTANT

Key Chips are precision parts. It may be damaged by heat, shock, or static electricity. Please handle with care

1 Remove 2 screws. Unlock with the Master Key and remove the Front Door R.

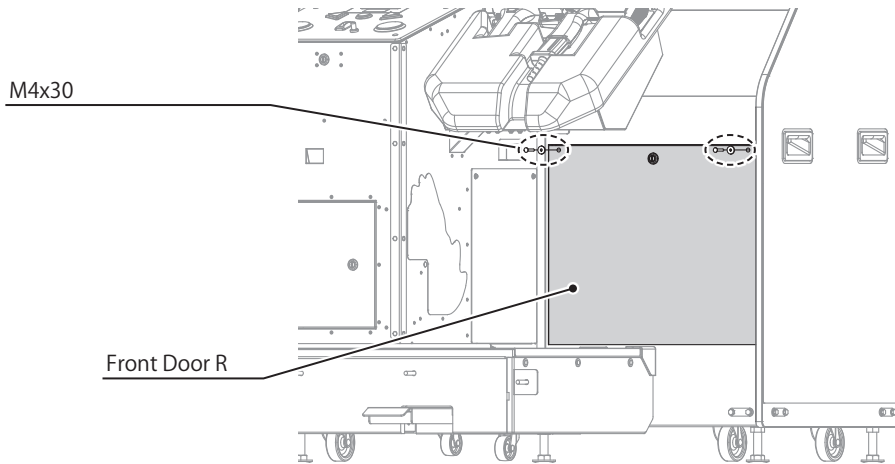

2 Insert the Key Chip into Game Bd.

Parts Used

Key Chip

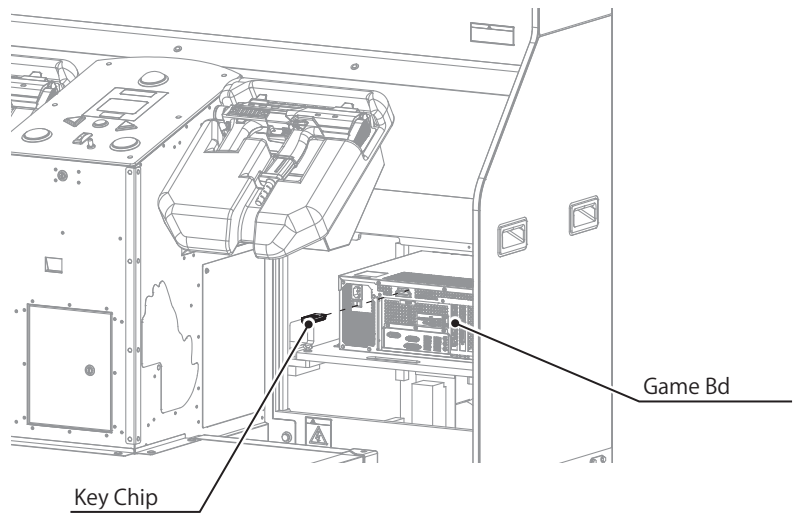

6-12 CONNECT DVD DRIVE

Please prepare the supplied software installation cable, software installation USB cable, and separately sold DVD Drive kit.

Connect the DVD Drive to install the software. For safety and prevention of erroneous operation, connect an optional DVD Drive before connecting the power cord of the cabinet.

- 1 Connect the two connectors of the included soft installation cable and the soft installation USB cable.

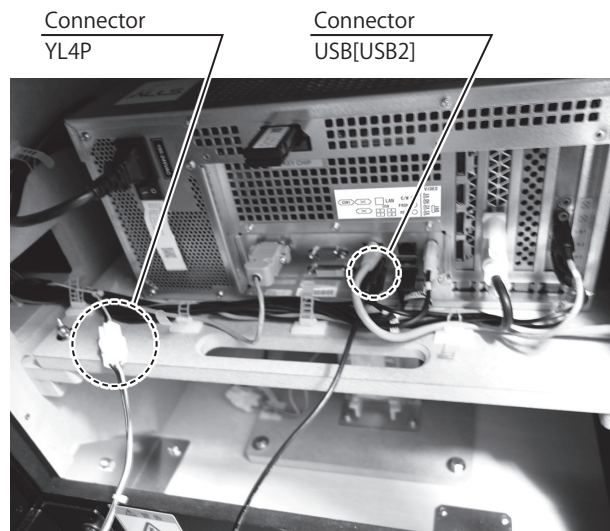
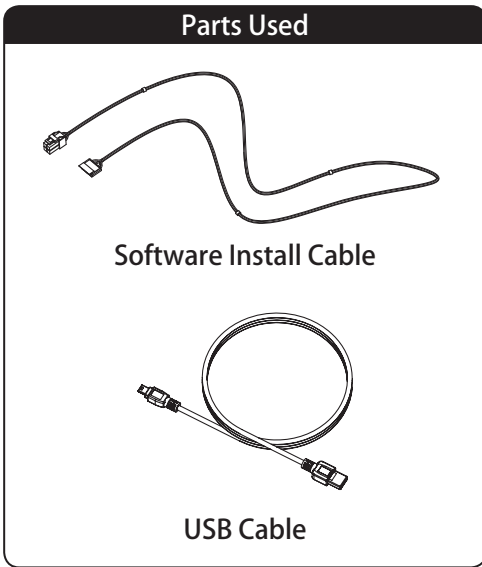

- 2 Connect two connectors to the rear of the drive.

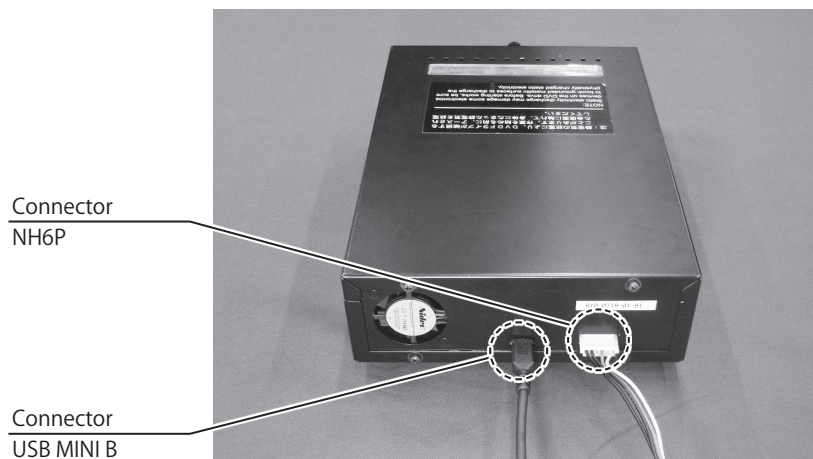

6-13 POWER SUPPLY & GROUND CONNECTION

⚠ CAUTION

- Check the power cord for breaks or dents. If the cord is damaged, it may cause electric shock, electric leakage, or fire.
- Please use the power supply equipped with earth leakage circuit breaker. Using a power source without an earth leakage circuit breaker may cause a fire when leakage occurs.
- Please prepare the "indoor grounding terminal that is reliably grounded". This product has a Ground Terminal. Please connect the Ground Terminal to the indoor Grounding Terminal with a Grounding Wire. Failure to properly ground may result in electric shock or malfunction.
- Do not expose the power cord or the Grounding Wire. In an exposed state, the wire is prone to damage such as stumble. Failure to do so may cause electric shock, short circuit, or fire. Please place it in a position that does not interfere with customer's passage or attach a cover.
- When using the grounding screw and Grounding Terminal of the AC unit, do not ground the Ground Wire while it is exposed. It may cause electric shock, short circuit, fire. Please use a round terminal for M4 with a rating of 15 A or more for the cabinet and ground it securely.

STOP IMPORTANT

Do not perform a grounding operation on the earth terminal of the AC unit if the Ground Wire is grounded with the built-in power cord Ground Wire.

When grounding using the earth terminal of the AC unit, do not ground with the Ground Wire with built-in power cord. It may cause malfunction or malfunction.

The AC unit has a power switch, a circuit protector, a grounding screw, and an inlet for connecting the power cord.

1 Confirm that the power switch is OFF.

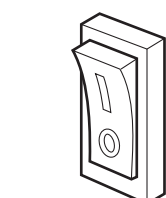

Power OFF

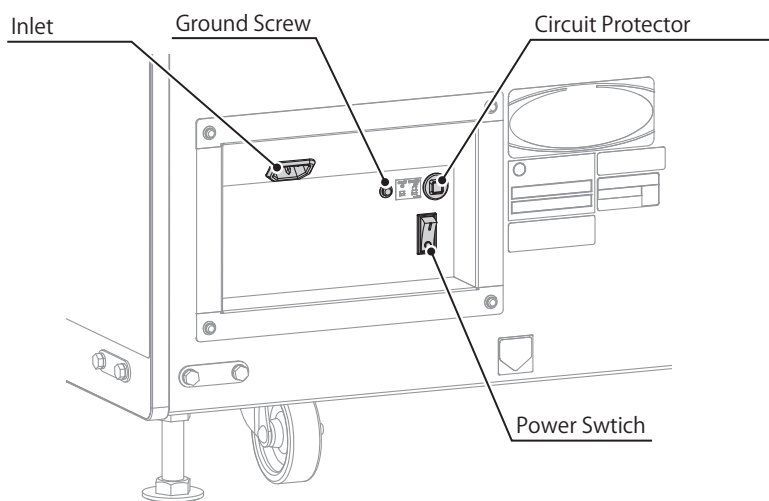

AC Unit

- 2 Insert the connector of the power cord firmly into the inlet of the AC unit and the plug of the power cord firmly into the outlet.

Parts Used

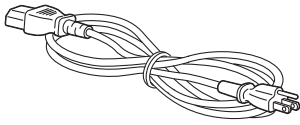

Power Lead

When connecting to a Power Outlet that has a Grounding Terminal

The included power cord has a Ground Wire built-in. Connect the power cord to the AC unit and connect the plug of the power cord to the "power outlet provided with a Ground Terminal".

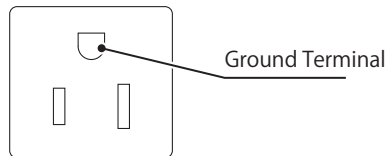

Example of a Power Outlet with a Grounding Terminal

When using a separately prepared Ground Wire

If you do not have a "Power Outlet with Ground Terminal", connect the grounding screw or Ground Terminal of the AC unit and the grounding mechanism with a separately prepared Grounding Wire and be sure to ground it.

Please remove the earth screw of the AC unit once and tighten it by passing it through the round terminal of the Ground Wire.

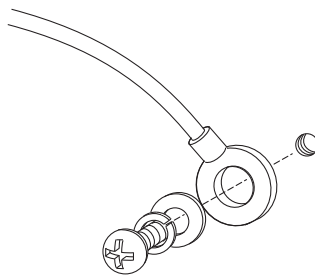

Connection of Earth Wire

When using a Commercially Available Conversion Adapter

When supplying power using a commercially available conversion adapter, connect the Ground Terminal of the adapter to the "earth terminal that is securely grounded"

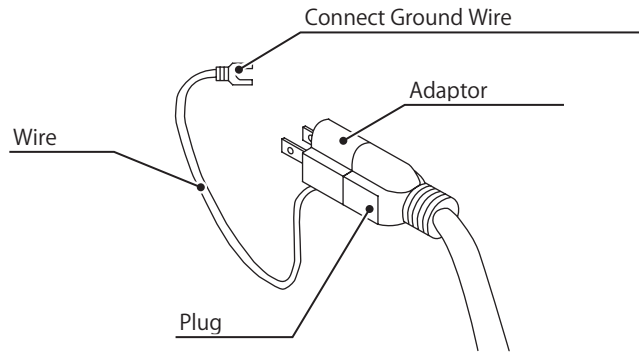

- 3 Perform the indoor wiring of the power cord. Attach the wiring cover and protect the power cord.

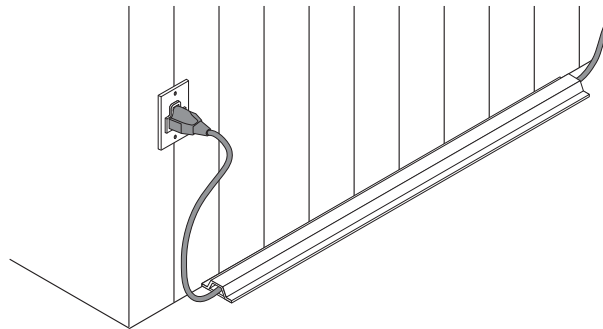

6-14 SOFTWARE INSTALLATION

CAUTION

- Turn off the power immediately if there is any operation or abnormality other than the explanation in this manual. Failure to turn off the power may cause electric shock or fire.
- Software installation is performed with the live part of the cabinet exposed. Do not touch the exposed part of the cabinet while live. It may cause electric shock, short circuit, fire
- Direct vision of the laser beam inside the DVD Drive may cause visual disturbance. Do not look inside the DVD Drive.

STOP IMPORTANT

- Do not carry out any other work until the soft installation finishes.
- If the software fails to install correctly, please contact SEGA.

STOP **IMPORTANT**

- Do not turn off the power while the DVD Drive access lamp is lit or blinking. This will cause failure of the drive
- Do not let foreign objects such as liquid, metal, or cigarette smoke get inside the DVD Drive
- Do not touch the lens inside the DVD Drive. As this may cause failure to read data
- The static electricity of the human body may damage the electronic parts. Take measures such as touching a grounded metal surface before work and discharge static electricity
- The disc tray is inoperable for 30 seconds when powered on and will only operate when power to the drive is ON
- Please keep DVD soft kit, DVD Drive kit, software installation cable and software installation USB cable in a secure place after software installation
- If software installation is not possible, an error will be displayed

STOP IMPORTANT

- Do not use damaged DVD as It may cause abnormal operation
- Place the DVD in the DVD Drive with the printed side facing up
- Do not put fingerprints or dust on the DVD
- Do not use solvents such as benzine and thinner, record spray, antistatic agent etc. for caring for the DVD.
- Do not use the DVD as shown below, as it may cause malfunctions:
 - Those with damage such as cracks, warping
 - Those with paper or a seal affixed
 - Seals, tapes and others with traces
- If the dirt is bad, please include water in a soft cloth, wipe it dirty firmly

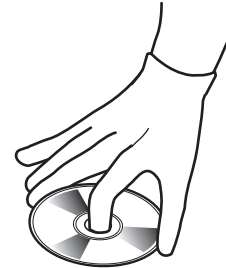
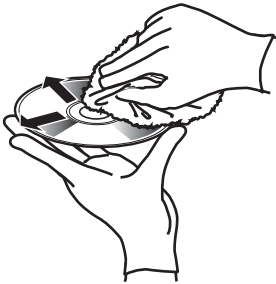

Software installation takes around 50 minutes.
This will take longer if a system update is required.

- 1 Remove one thumbscrew and remove the Case Lid of the DVD Drive.

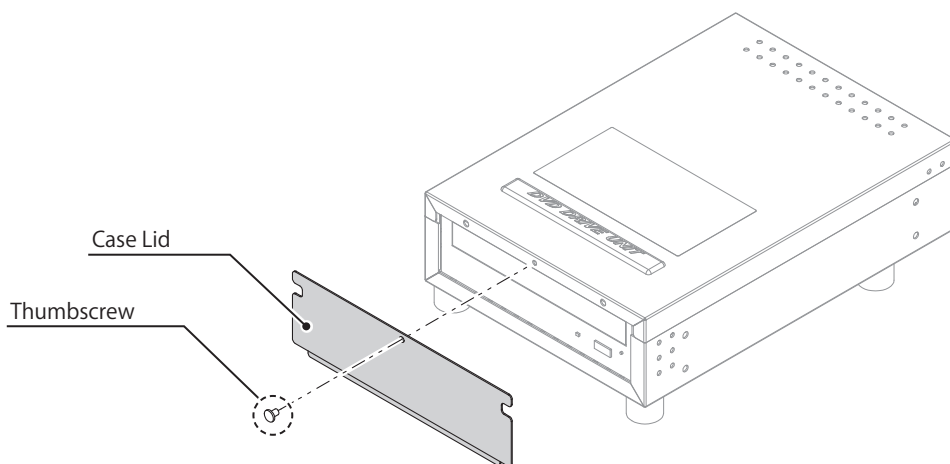

- 2 Turn on the power switch.

- 3 A start screen of Game BD is displayed on the LCD monitor.

- 4 Approximately one minute later, "Please Insert Disc 1" will be displayed on the screen.

- 5 Eject the disc tray and insert DVD (Disc 1) of the DVD. Be sure to set the print side up.

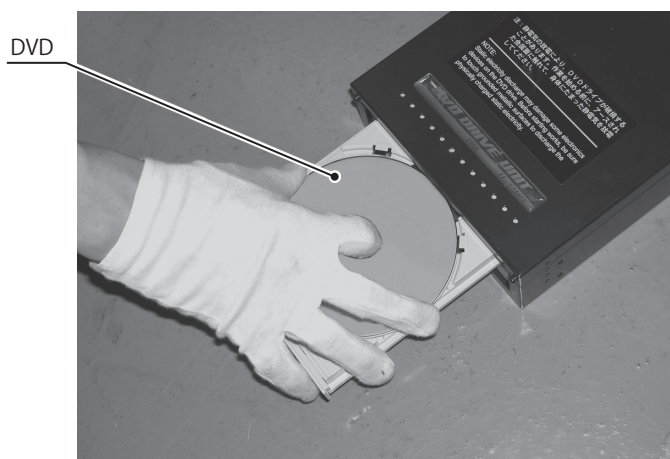
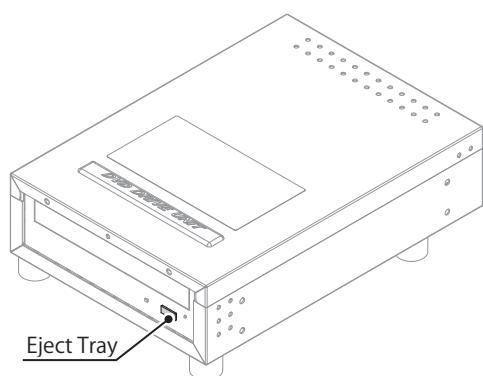

- 6 Push the switch on the DVD Drive and return the tray. Software installation from the DVD will start automatically and "Program image loading" will be displayed. Do not turn off the power of the cabinet during soft installation.
- 7 When the tray opens automatically, insert the second DVD (Disc 2) into the tray. Be sure to set the print side up.
- 8 Push the switch on the DVD Drive and return the tray. Software installation from DVD will start automatically. When the soft installation is completed, the game starts automatically.
- 9 Perform the system update. If update is not required, proceed to step 12.

STOP IMPORTANT

Do not turn off the power while updating the system. Turning off the power may cause Game Board to break down.

- 10 After "Disc change, please see Disc 1.", Press switch on the DVD Drive and pull out the tray. Set the first DVD of the DVD software kit (Disc 1) on the tray. Be sure to set the print side up.
- 11 Push the switch on the DVD Drive and return the tray.
- 12 When "ERROR 0919 DVD Drive is connected" is displayed, press the DVD Drive switch, take out the tray and take out the DVD.
- 13 Push the switch on the DVD Drive and return the tray. The tray will not move when the power is turned off.
- 14 Turn off the power switch.
- 15 Insert the Case Lid into the DVD Drive and secure with a single thumbscrew.

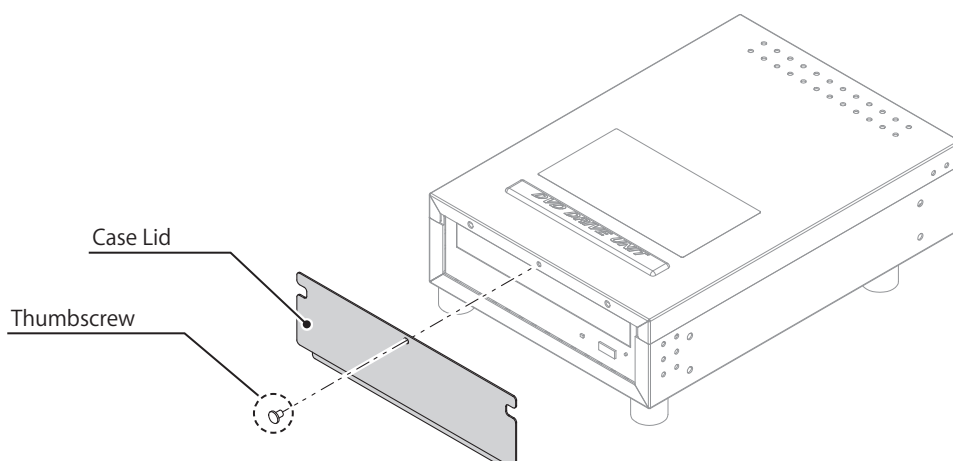

16 Refer to "6-13" and remove the DVD Drive in reverse order.

17 Install Front Door R and lock with Master Key. Secure with 2 screws.

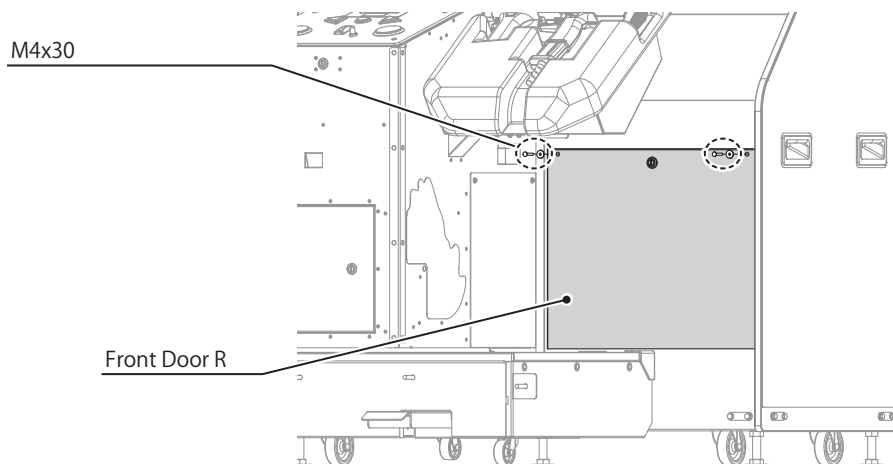

18 Please save the DVD Drive kit and soft installation cable, soft installation USB cable, DVD soft kit in a place free from dust and cigarette smoke.

7 PRECAUTIONS WHEN MOVING

7-1 MOVING THE MACHINE

WARNING

- Always disconnect the power cable before moving the product. If it is moved with the power cable connected, the cable could be damaged, causing fire or electric shock.
- To move the unit over the floor, pull in the adjusters and have the casters contact the floor. While moving the unit, be careful that the casters do not roll over the power cord or the ground wire. If cord or wire is damaged, there could be electrical shocks and/or short circuits.
- When crossing a sloped or stepped area, disconnect the Monitor Cabinet, Control Cabinet and Rear Cabinet. If you tilt them while connected together, the connection points may be damaged and personnel could be injured.
- When lifting the cabinet up steps, you must hold it by the designated handles or by the bottom surface. Lifting it by any other area may lead to damage or disfiguration to that part or surrounding parts due to the weight of the cabinet and could also lead to injury of personnel.
- When tilting the cabinet to move it across a sloped or stepped area, always use at least two people. Attempting such an operation alone can lead to accident or injury.
- When moving the components separately, take care concerning the direction you push the Monitor and Rear Cabinet in. These elements may fall over, causing damage or an accident.

CAUTION

- When moving the components, do not push any of the plastic elements or shaped parts and do not use them to pull the components along. This may damage the parts or the surrounding parts and this could lead to accidents or injury.
- After dividing the components to move them, do not use the Control Units in the Monitor Cabinet to push or pull the cabinet. This may damage or disfigure these parts and lead to malfunctions or injury.
- When moving the separated components, be sure to push/pull each cabinet lengthways. Trying to move the cabinet any other way may cause the cabinet to topple over.

STOP

IMPORTANT

- When moving the cabinet, do not hold, push, or pull the Control Units. This may disfigure or damage them.
- If you need to move components through a narrow or low door and the only way to get the separated components through is to turn them on their side, or if a separation method other than those described in this manual is required, either make a request to the office listed in this document or the place of purchase to perform the operation or contact them regarding how to perform it. Carelessly turning the components onto their side or separating them in ways other than those depicted in this manual may lead to irreparable damage.
- Do not press the monitor screen. The screen can be easily damaged and cannot be repaired if it is, meaning complete replacement will be necessary.

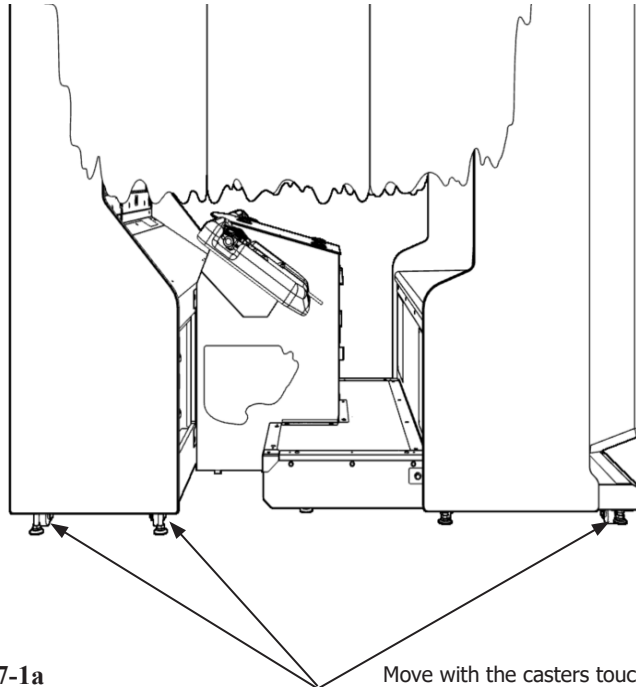

FIG. 7-1a

Move with the casters touching the floor.

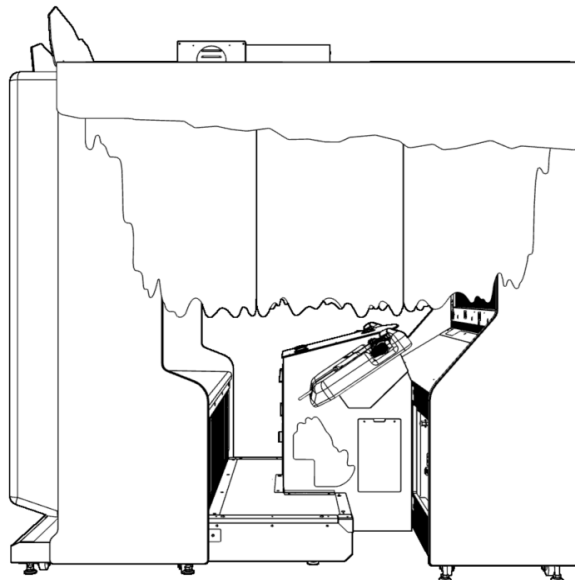

FIG. 7-1b

Separate components when moving over a sloped or stepped area.

8 GAME DESCRIPTION

1-1 GAME OUTLINE

After the coins are inserted, available Credits will display at the bottom of the screen. After required coins are inserted, the text will change from "PLEASE INSERT COINS" into "PRESS START BUTTON" . The start button on the Cabinet will then be flashing.

Coin system can accumulate up to 24 Credits. Credits beyond 24 will not be counted and returned to Player, but will be recorded by system internal counter.

Based on the difference of test mode settings, "INSERT COIN(S)" / " INSERT MORE COIN(S)" may change to "SWIPE CARD TO PLAY" .

The Players role is based on which side the "START" button is pressed. Press "START" button once to start the game. If you choose the left side, you will be Player 1, and the right side will be Player 2.

1-2 METHOD OF OPERATION

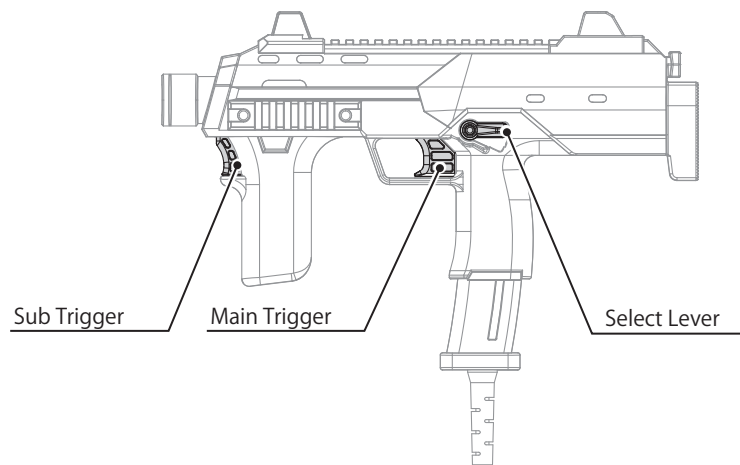

Controller Diagram

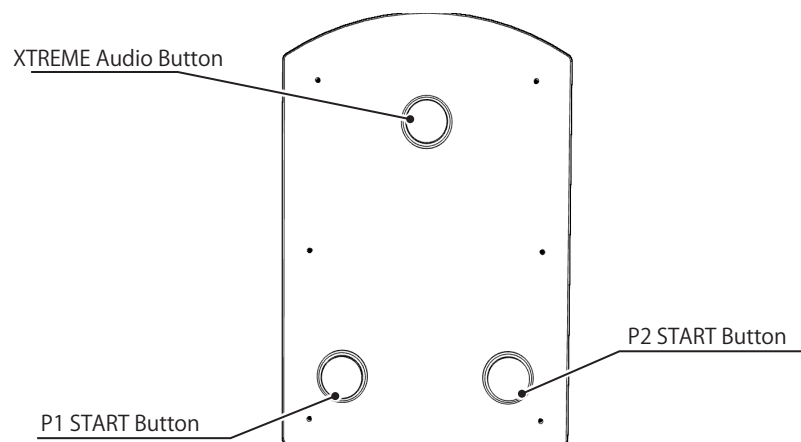

Control Panel Diagram

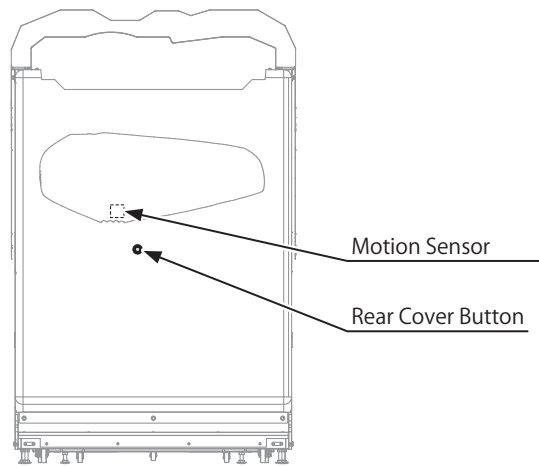

Rear Cabinet Diagram

■ Item Description

Controller	Aims crosshair during Game and moves cursor on screen in menus
Main Trigger	Fires bullets to defeat enemies and confirms selection in menus
Sub Trigger/Select Lever	When the Player has items available, this switches between multiple available items
P1 START Button	Left Seat (P1) confirms the Credit on Game start and Continue
P2 START Button	Right Seat (P2) confirms the Credit on Game start and Continue
XTREME AUDIO Button	This button controls the extra audio features of the Cabinet. It is ON by default. If the Player feels the Cabinet is too loud, they can press this button to turn the audio features OFF. Pressing the button again will turn the features back ON
Rear Cover Button	Activates Cabinet visual and audio effects
Motion Sensor	Activates Cabinet visual and audio effects

1-3 HOW TO PLAY

Credit Input

When a Credit is inserted, the Credit display on the attract screen will show the amount of Credits available.

When the Credit requirements have been met, the message "INSERT COIN(S)" will change to "PRESS START BUTTON" and both START buttons will begin to flash.

Up to 24 Credits can be counted at a time.



Attract Screen

Player Entry

This will detail the Player Entry Screen.

Player 1 will be on the left hand side of the screen and Player 2 will be on the right hand side of the screen. The Player # is determined by which side START button the Player presses.



Entry Screen

Mode Select

Select a Game Mode by shooting the desired option.



Mode Select Screen

Modes

NORMAL MODE	Recommended for first time Players
MASTER MODE	Recommended for expert or veteran Players

There are two kinds of game modes: "NORMAL MODE" and "MASTER MODE".

"NORMAL MODE" is the standard gameplay mode and there are assistance events for Players. This mode is recommended for Players who are playing for the first time.

"MASTER MODE" is a mode for advanced Players where enemies are stronger and faster.

Item Selection

The Player can choose two items they wish to use during their game.

Each item has it's own abilities, number of uses, bullets etc. which are limited.

The Player(s) selects their 2 items by shooting them with the controller.

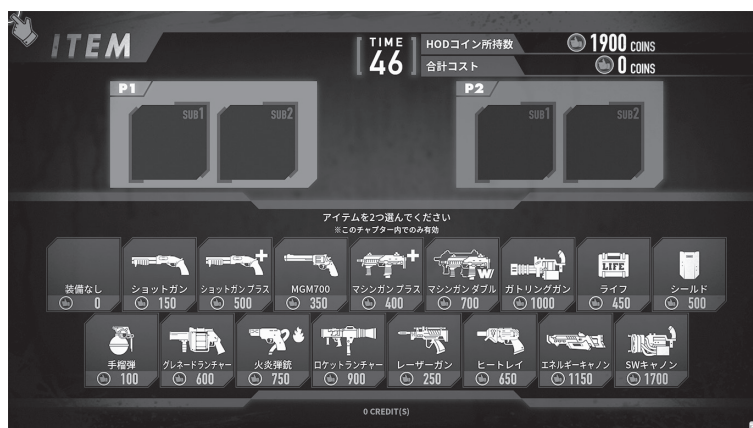

Item Select Screen

The Player can select "Reset" to clear their item selections.



Item Selection Confirmation Screen

Gameplay

When the game begins, a video demonstration will follow giving the Player information on how to play the game. After this, it will transition to game play



Video Demo Screen

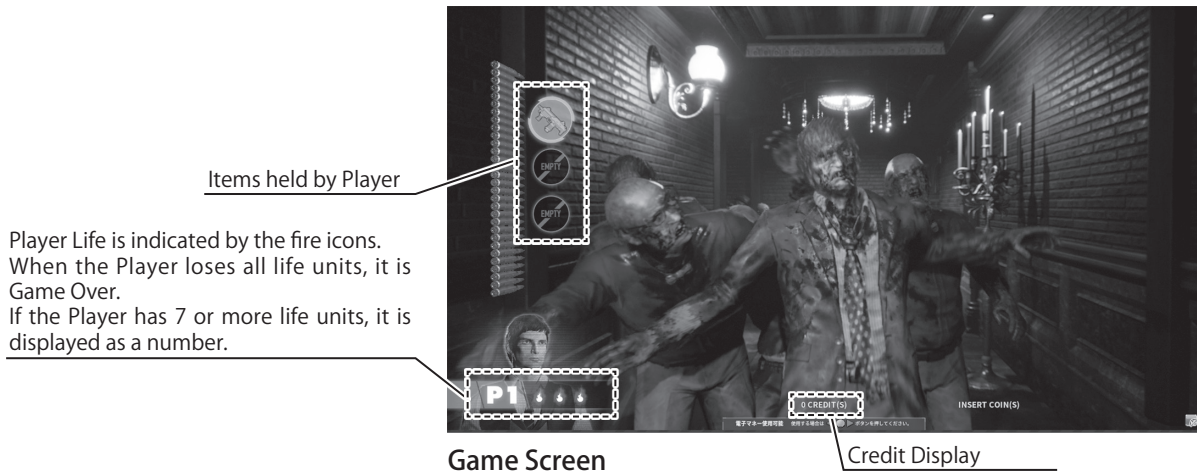

A second Player can join a game in progress by inserting a Credit and pressing START. When a Credit has been entered, the Player not in the game will have their START button flash until it is pressed.

Continue

When a Player is out of life, the Game is over and the Continue Screen will be displayed. The Player can enter a Credit to continue their Game before the time on screen expires. Once a Player has entered a Credit, they can press START to resume their game.

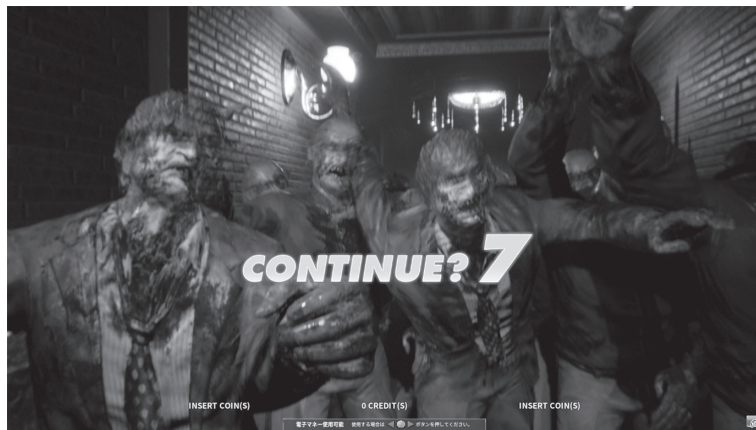

Continue Screen

Ranking

Upon completing all stages of the Game, the Player can enter their name if their score was within the Top Rankings.

Rankings are split into different categories:

NORMAL MODE 1Player AGENT RANKING	1-20 Rank
MASTER MODE 1Player AGENT RANKING	1-20 Rank
NORMAL MODE 2PlayerS AGENT RANKING	1-20 Rank
MASTER MODE 2PlayerS AGENT RANKING	1-20 Rank



NORMAL MODE 1Player AGENT RANKING



MASTER MODE 2PlayerS AGENT RANKING

9 EXPLANATION OF TEST AND DATA DISPLAY

WARNING

Do not touch any parts that are not specified in these directions. Touching unspecified locations may lead to electric shock or cause short circuits.

CAUTION

- Be careful that your finger or hand does not get caught when opening/closing the coin chute door.
- Operating the TEST Button and SERVICE Button during Test Mode may be slightly uncomfortable, due to the position of the buttons in relation to the cabinet seats. Take care not to hurt your shoulder or back, or scratch yourself on any parts of the cabinet.

STOP IMPORTANT

- When you enter the Test Mode, Fractional Coin and Bonus Adder data is erased.
- Adjust the sound to the optimum volume, taking into consideration the environmental requirements of the installation location.
- Removing the Coin Meter circuitry renders the game inoperable.
- Have a flashlight on hand and operate in Test Mode very carefully. The cabinet interior is dark and narrow and you could easily make mistakes in operation.

Perform tests and data checks periodically by manipulating the TEST Button and SERVICE Button in the cabinet. Follow the instructions in this chapter to conduct checks when the game machine is first installed, when money is being collected, or when the game machine does not operate properly.

Shown below are the tests and screens to be used for different problems.

9-1 SWITCH UNIT AND COIN METER

The SWITCH UNIT and COUNTERS are housed within the COINTOWER. To access these controls you will need to open the COIN door. The switches and counters can be found directly on the rear face of the Tower.

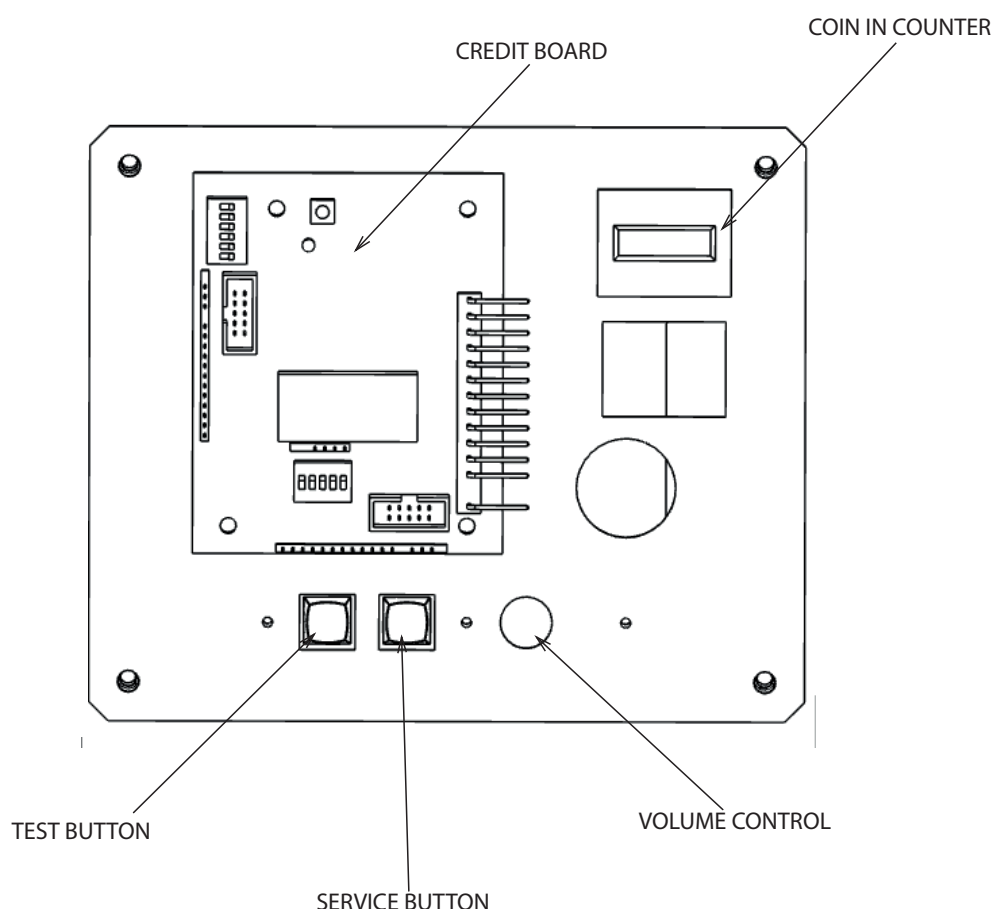
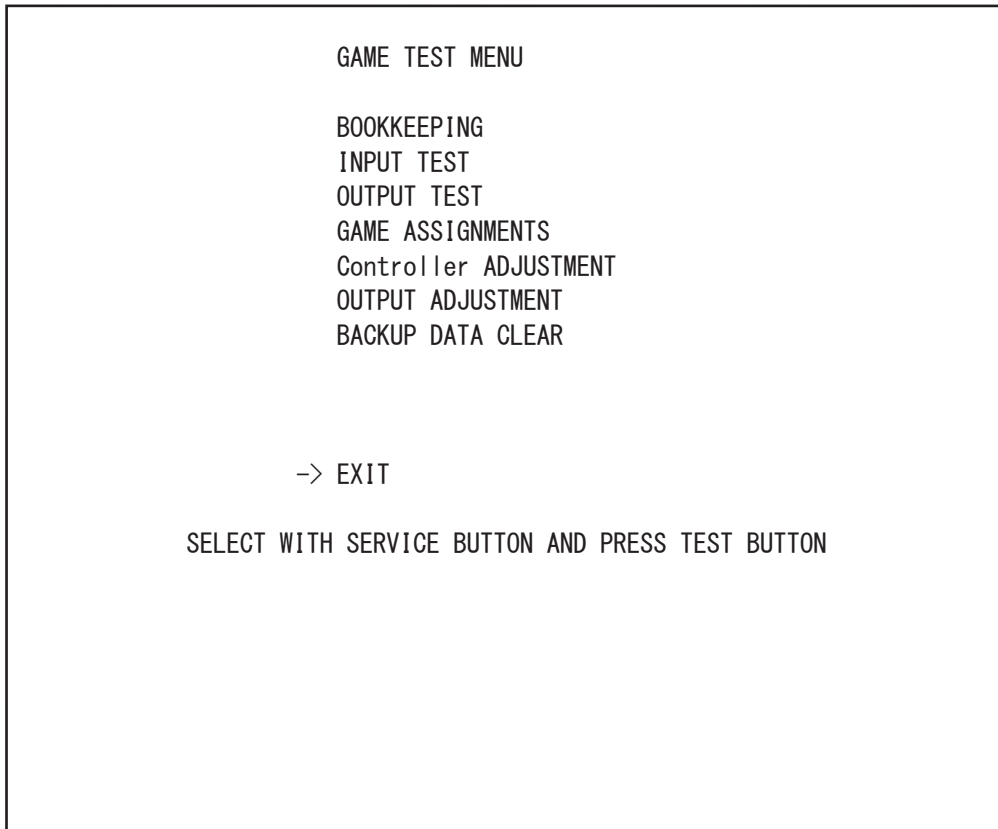

FIG. 9-1a Switch Unit

DEVICE	FUNCTION
TEST BUTTON	Press to enter TEST MODE - Also used to enter choices selected within TEST MODE
SERVICE BUTTON	Press for SERVICE CREDIT - Also used to scroll through TEST MENUS
COIN IN COUNTER	Counts inserted coins (£0.10 or \$0.10 = 1 count)
VOLUME CONTROL	Adjusts audio level

9-2 GAME TEST MODE

This is the main Test Mode menu. Here you can access a number of different sub menus to test different aspects of the Cabinet to ensure they are all working correctly.



Test Mode menu

Use Service to cycle through items. Use Test to select an item and view that item's sub-menu. Select EXIT to return to Game.

BOOKKEEPING	Displays Game and Cabinet statistics
INPUT TEST	Used to check all Input devices are working correctly
OUTPUT TEST	Used to check all Output devices are working correctly
GAME ASSIGNMENTS	Used to change Game related settings
Controller ADJUSTMENT	Used to calibrate Control Unit
OUTPUT ADJUSTMENT	Used to change levels of Output devices
BACKUP DATA CLEAR	Clears all data on Cabinet
EXIT	Exit Test Mode and return to Game

9-3 BOOKKEEPING

This menu displays statistics for credits, gameplay, and the Cabinet overall.

BOOKKEEPING		PAGE 1/3
COIN 1		*
COIN 2		*
TOTAL COINS		*
COIN CREDITS		*
SERVICE CREDITS		*
TOTAL CREDITS		*
PRESS TEST TO CONTINUE		

Bookkeeping Menu (1/3)

Use the Test button to proceed to Bookkeeping Menu #2

COIN 1	Number of coins put into Coin Chute #1
COIN 2	Number of coins put into Coin Chute #2
TOTAL COINS	Total number of coins put into Coin Chutes
COIN CREDITS	Number of standard Credits
SERVICE CREDITS	Number of Service Credits
TOTAL CREDITS	Total number of Credits

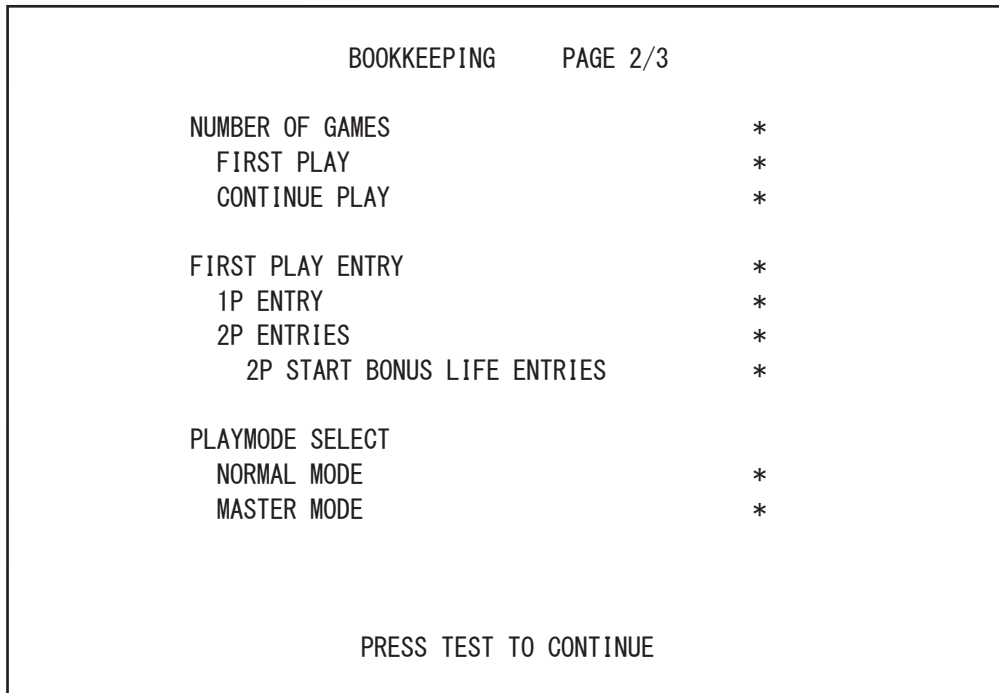

Bookkeeping Menu (2/3)

Use the Test button to proceed to Bookkeeping Menu #3

NUMBER OF GAMES	Total number of Games played
FIRST PLAY	Total number of Games played from the start of the Game
CONTINUE PLAY	Total number of Continues played
FIRST PLAY ENTRY	Total number of Solo/2P Games have been played
1P ENTRY	Total number of Single Player Games
2P ENTRIES	Total number of 2P Games
2P START BONUS LIFE ENTRIES	Total number of Games entered with BONUS LIFE at the start of the Game
PLAYMODE SELECT	Total number of times a play mode has been selected
NORMAL MODE	Total number of Games NORMAL MODE was selected
MASTER MODE	Total number of Games MASTER MODE was selected

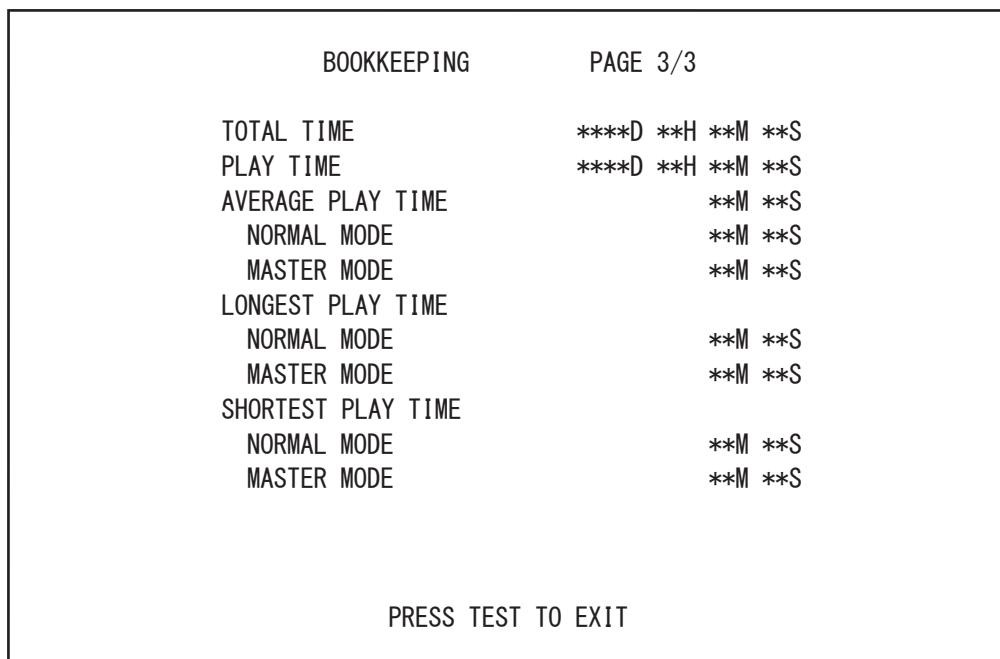

Bookkeeping Menu (3/3)

Use the Test button to return to the Test Mode menu.

TOTAL TIME	Total time the Cabinet has been powered on
PLAY TIME	Total time the Cabinet has been in Game
AVERAGE PLAY TIME	Average play time for a Game
NORMAL MODE	Average play time for a NORMAL MODE Game
MASTER MODE	Average play time for a MASTER MODE Game
LONGEST PLAY TIME	Longest recorded play time for a Game
NORMAL MODE	Longest recorded play time for a NORMAL MODE Game
MASTER MODE	Longest recorded play time for a MASTER MODE Game
SHORTEST PLAY TIME	Shortest recorded play time for a Game
NORMAL MODE	Shortest recorded play time for a NORMAL MODE Game
MASTER MODE	Shortest recorded play time for a MASTER MODE Game

9-4 INPUT TEST

Use this menu to check the operation of the Input devices.

INPUT TEST		
	PLAYER1	PLAYER2
Controller TRIGGER	OFF	OFF
Controller SELECT	OFF	OFF
Controller WEAPON	OFF	OFF
Controller X	*	*
Controller Y	*	*
Controller SCREEN IN	OUT	OUT
P1 START		OFF
P2 START		OFF
BLAST		OFF
REAR COVER EYE		OFF
REAR COVER MOTION SENSOR		OFF
SERVICE		OFF
TEST		OFF
PRESS TEST BUTTON AND SERVICE BUTTON TO EXIT		

Input Test Menu

To exit this menu, press the Test and Service buttons together at the same time.

Controller TRIGGER	It is normal if "OFF" indication turns "ON" when the main trigger of the Controller is pulled
Controller SELECT	It is normal if the "OFF" indication turns "ON" when the Controller's select lever is operated
Controller WEAPON	It is normal if the "OFF" indication turns "ON" when the sub trigger of the Controller is pulled
Controller X	Check the X coordinate value of the Controller's aim It is normal if the numerical value fluctuates when moving the aim of the Controller toward the screen to the left or right
Controller Y	Check the Y coordinate value of the Controller's aim It is normal if the numerical value fluctuates when moving the aim of the Controller toward the screen to the left or right
Controller SCREEN IN	It is normal if it is "IN" when the Controller's aim is on the screen and "OUT" when it is outside the screen

P1 START	It is normal if "OFF" indication turns "ON" when the START Button is pressed
P2 START	It is normal if "OFF" indication turns "ON" when the START Button is pressed
BLAST	It is normal if "OFF" indication turns "ON" when the START Button is pressed
REAR COVER EYE	It is normal if "OFF" indication turns "ON" when the START Button is pressed
REAR COVER MOTION SENSOR	Approaching to the back of the cabinet, if the "OFF" display turns "ON" it is normal
SERVICE	It is normal if the "OFF" display turns "ON" when the service button is pushed
TEST	It is normal if the "OFF" display turns "ON" when the test button is pushed

9-5 OUTPUT TEST

Use this menu to check the operation of the Output devices..

OUTPUT TEST	
P1 START LAMP	OFF
P2 START LAMP	OFF
BLAST LAMP	OFF
P1 Controller HOLDER LAMP	OFF
P2 Controller HOLDER LAMP	OFF
P1 CEILING LAMP	OFF
P2 CEILING LAMP	OFF
REAR COVER LAMP	OFF
REAR COVER EYE LAMP	OFF
FIGURE LAMP	OFF
COIN BLOCKER	ON (REJECT)
-> EXIT	
SELECT WITH SERVICE BUTTON AND PRESS TEST BUTTON	

Output Test Menu

Use Service to cycle through items and Test to turn a device ON or OFF.

P1 START LAMP	Lights when the lamp of the START Button is "ON", and goes out when it is "OFF".
P2 START LAMP	Lights when the lamp of P2 START Button is "ON", and goes out when it is "OFF".
BLAST LAMP	Lights when the XTREME Audio Button's lamp is "ON" and turns off when it is "OFF".
P1 Controller HOLDER LAMP	OFF (turn off) → RED (lights up in red) → GREEN (lights green) → BLUE (lights up in blue) → WHITE (lights up in white) → RED FADE (blinks in red) → GREEN FADE (blinks green) → BLUE. You can check FADE (flashing blue) → WHITE FADE (blinking white).
P2 Controller HOLDER LAMP	OFF (turn off) → RED (lights up in red) → GREEN (lights green) → BLUE (lights up in blue) → WHITE (lights up in white) → RED FADE (blinks in red) → GREEN FADE (blinks green) → BLUE. You can check FADE (flashing blue) → WHITE FADE (blinking white)
P1 CEILING LAMP	OFF (turn off) → RED (lights up in red) → GREEN (lights green) → BLUE (lights up in blue) → WHITE (lights up in white) → RED FADE (blinks in red) → GREEN FADE (blinks green) → BLUE. You can check FADE (flashing blue) → WHITE FADE (blinking white).
P2 CEILING LAMP	OFF (turn off) → RED (lights up in red) → GREEN (lights green) → BLUE (lights up in blue) → WHITE (lights up in white) → RED FADE (blinks in red) → GREEN FADE (blinks green) → BLUE. You can check FADE (flashing blue) → WHITE FADE (blinking white).
REAR COVER LAMP	OFF (turn off) → RED (lights up in red) → GREEN (lights green) → BLUE (lights up in blue) → WHITE (lights up in white) → RED FADE (blinks in red) → GREEN FADE (blinks green) → BLUE. You can check FADE (flashing blue) → WHITE FADE (blinking white).
REAR COVER EYE LAMP	Lights when the lamp on the Rear Cover Button is "ON", and goes out when it is "OFF".
FIGURE LAMP	OFF (turn off) → RED (lights up in red) → GREEN (lights green) → BLUE (lights up in blue) → WHITE (lights up in white) → RED FADE (blinks in red) → GREEN FADE (blinks green) → BLUE. You can check FADE (flashing blue) → WHITE FADE (blinking white)
COIN BLOCKER	When you turn on coin when "ON (REJECT)", you will fall into the coin return slot. When you insert a coin when "OFF (ACCEPT)", it falls into the cash box.

9-6 GAME ASSIGNMENTS

Use this menu to change Game settings such as difficulty and starting Player life.

GAME ASSIGNMENTS	
GAME DIFFICULTY	NORMAL
LIFE	
MAX LIFE	6
INITIAL LIFE	3
2P START BONUS LIFE	×2
BLAST BUTTON	DEFAULT
REAR COVER LAMP	AUTO
REAR COVER MOTION SENSOR	ON
Controller SENSOR ID	F1
-> EXIT	
SELECT WITH SERVICE BUTTON AND PRESS TEST BUTTON	

Game Assignments Menu

Use Service to cycle through items. Use Test to select an item and change values/options of selected item. Use EXIT to return to Test Main Menu.

GAME DIFFICULTY	Choose from: VERY EASY → EASY → NORMAL → HARD → VERY HARD. (Default Difficulty = NORMAL)
LIFE	Determines Player life options
MAX LIFE	Determines the limit on how much life the Player can accrue (Default = 6. Value Range = 1 - 36)
INITIAL LIFE	Determines how much life the Player starts with (Default = 3 Value Range = 1 - 12)
2P START BONUS LIFE	Determines Bonus Life gained (only when 2 Players start the game at the same time does the Bonus Life apply). The amount of Bonus Life is multiplied by the Initial Life value. (Default = Initial Life : X2. Value Range = OFF, X2, X2.5, X3)
BLAST BUTTON	Determines whether the XTREME Audio is active at the start of play (Default = ON)
DEFAULT	XTREME Audio is active from the Game start
REVERSE	XTREME Audio is not active until pressed by Player

REAR COVER LAMP	Select pattern of Rear Cover Lamp. When set to AUTO the pattern of the RCL changes every month: (Default = AUTO. Value Range = AUTO、SCARLET DAWN 01、SCARLET DAWN 02、HORROR 01、HORROR 02、NEW YEAR、VALENTINE、SPRING、SUMMER、HALLOWEEN、CHRISTMAS、RED、BLUE、YELLOW、WHITE、PURPLE、OFF)
REAR COVER MOTION SENSOR	Select function of motion sensor. (Default = ON)
	ON Sensor activates effects when tripped
	AUTO Sensor will activate at set intervals without being tripped
OFF Sensor activates visual effects only	
Controller SENSOR ID	When using two or more units side by side, please set to different value to avoid crosstalk of motion sensor (Default = F1. Value Range = F1、F2、F3、F4)

9-7 CONTROLLER ADJUSTMENT

Use this menu to calibrate and correct Controller alignments.

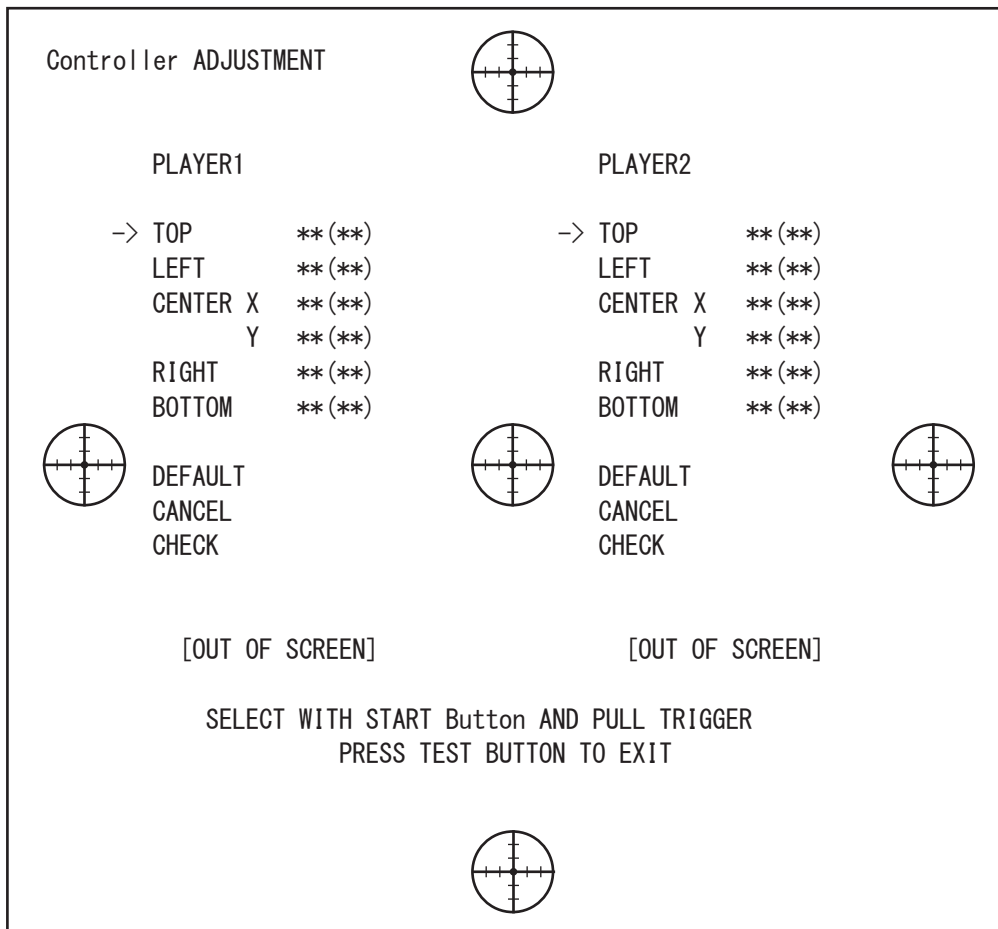

Controller Adjustment Menu

- P1 / P2 - Select the item with the START Button
- Press the test button to end the setting and return to the game test menu screen. At that time, the adjusted value is retained

PLAYER1	Configure P1 Controller
PLAYER2	Configure P1 Controller
TOP	Sets the correction value (analog value) at the upper end in the vertical direction. Target the top mark with the Controller and subtract the main trigger to determine the analog value. At this time, the aimed left / right direction does not matter.
LEFT	Set the correction value (analog value) at the left end in the left-right direction. Target the left-most mark with the Controller, and subtract the main trigger to determine the analog value.
CENTER	Set the correction value (analog value) of the center. Target the center mark with the Controller, and subtract the main trigger to determine the analog value.
RIGHT	Set the correction value (analog value) at the right end in the left-right direction. Target the right-most mark with the Controller, and subtract the main trigger to determine the analog value.
BOTTOM	Set the correction value (analog value) at the bottom. Target the bottom mark with the Controller, and subtract the main trigger to determine the analog value
DEFAULT	Set the initial setting value (factory shipped) as the correction value (analog value)
CANCEL	Cancel this setting change and return to the previous value (the value displayed in parentheses)
CHECK	Aiming check can be performed from the set correction value (analog value). Pointing the Controller to the screen, a cursor indicating the landing position is displayed on the screen. The cursor is displayed at the landing position calculated using the current correction value (value displayed outside parentheses).
[OUT OF SCREEN]	When it recognizes that the Controller's aim is out of the screen, [OUT OF SCREEN] is displayed

Setting Controller Aim

This section will detail how to calibrate Controllers. The method is the same for both Controllers.

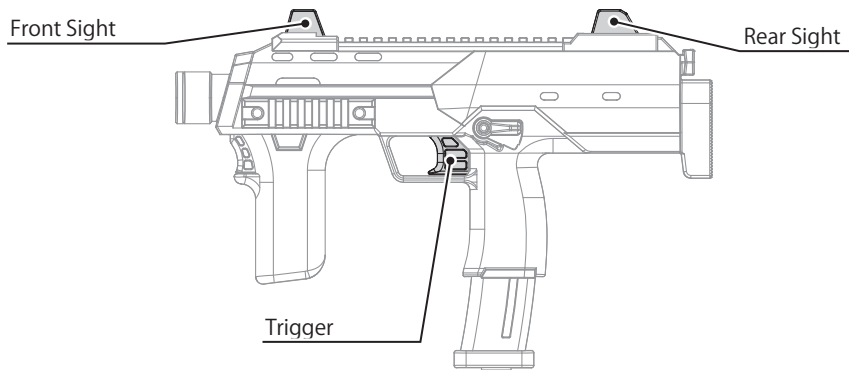

Controller Unit

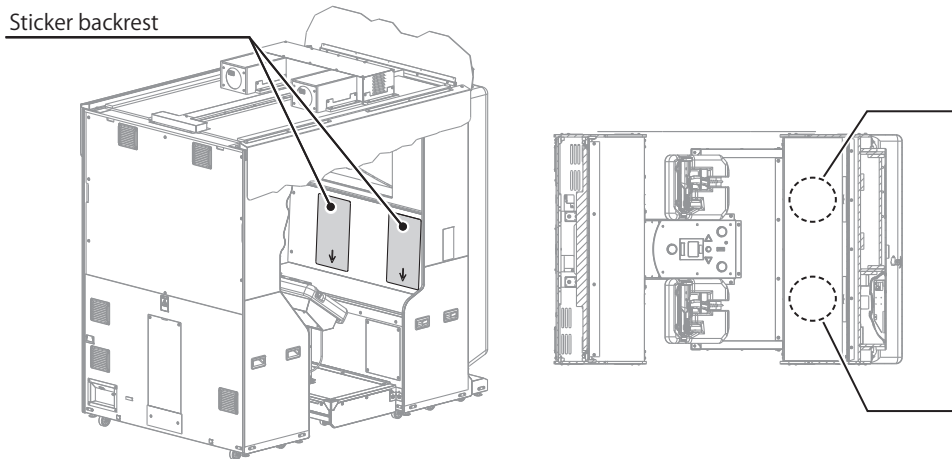

- 1 Sit in the seat and hold P1 Controller
Sit in front of the sticker backrest and sit deep into the seat.



- 2 Please check that "TOP" on the PLAYER 1 side of the Controller adjustment screen is selected.

3 Hold the Controller with both hands. Subtract the main trigger so that either the left or right eye line, the front site of the Controller and the rear site, and the marker displayed at the top of the screen are in a straight line. At this time, please hold the Controller vertically without tilting

Controller ADJUSTMENT

PLAYER1	PLAYER2
<p>-> TOP **(**)</p> <p>LEFT **(**)</p> <p>CENTER X **(**)</p> <p> Y **(**)</p> <p>RIGHT **(**)</p> <p>BOTTOM **(**)</p>	<p>-> TOP **(**)</p> <p>LEFT **(**)</p> <p>CENTER X **(**)</p> <p> Y **(**)</p> <p>RIGHT **(**)</p> <p>BOTTOM **(**)</p>
 <p>DEFAULT CANCEL CHECK</p>	 <p>DEFAULT CANCEL CHECK</p>
[OUT OF SCREEN]	[OUT OF SCREEN]
<p>SELECT WITH START Button AND PULL TRIGGER PRESS TEST BUTTON TO EXIT</p>	

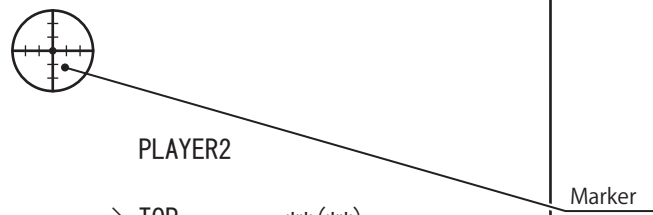

Marker



Controller Adjustment screen

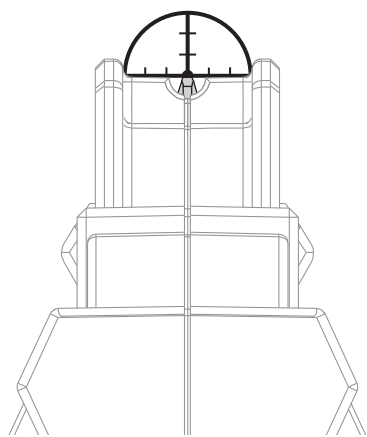

Straight line condition

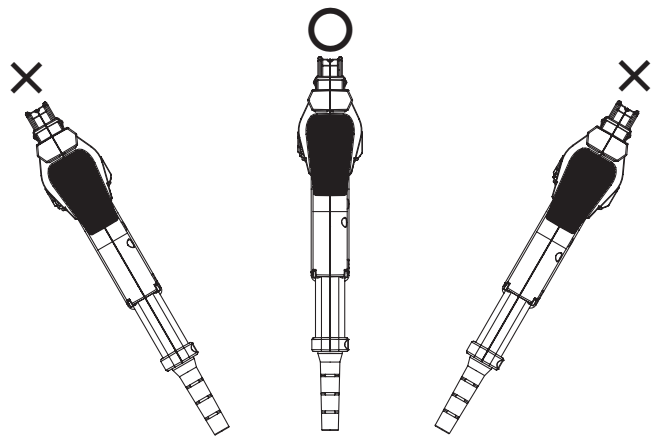

Hold the Controller vertically.

4 Press the P1 START Button and repeat steps for "LEFT", "RIGHT", etc.

- 5 Press the P1 START Button and select "CHECK". When turning the Controller toward the screen, the aim is displayed. Move the Controller and move the aim along the edge of the screen. If the aim does not disappear during the movement, the setting is over. If the aim disappears, proceed to step 13

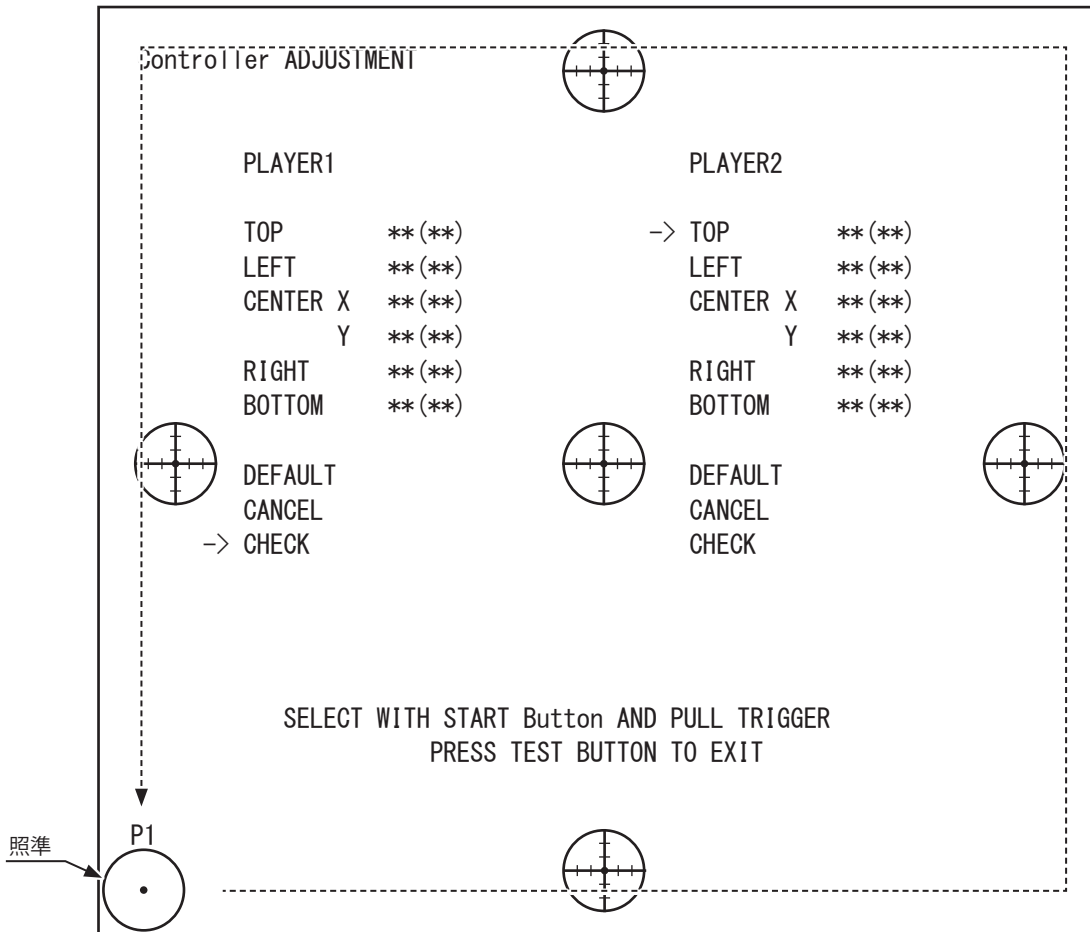

Controller Adjustment screen

- 6 To perform the calibration of a section again, select one of the items (TOP, RIGHT, LEFT etc.)
- 7 Pull the main trigger again and repeat the calibration procedure
- 8 Refer to step 5 and confirm the setting.

9-8 OUTPUT ADJUSTMENT

Various volume and output adjustments and confirmation of gimmick / vibration can be done from this Test menu.

OUTPUT ADJUSTMENT	
SPEAKER TEST	
FRONT LEFT SPEAKER	OFF
FRONT RIGHT SPEAKER	OFF
REAR LEFT SPEAKER	OFF
REAR RIGHT SPEAKER	OFF
CENTER SPEAKER	OFF
WOOFER SPEAKER	OFF
BLAST WOOFER SPEAKER	OFF
GIMMICK OUTPUT TEST	
SEAT VIBRATION	OFF
STEP VIBRATION	OFF
AIR GIMMICK	OFF
P1 Controller VIBRATION	OFF
P1 Controller VIBRATION	OFF
ALL SOUND VOLUME	15/20
ADVERTISE SOUND VOLUME	10/10
SENSOR VOICE VOLUME	10/10
WOOFER VOLUME	10/10
GIMMICK	
SEAT VIBRATION	10/10
STEP VIBRATION	10/10
AIR GIMMICK	10/10
P1 Controller VIBRATION	10/10
P2 Controller VIBRATION	10/10
-> EXIT	
SELECT WITH SERVICE BUTTON AND PRESS TEST BUTTON	

Output Adjustment Menu

Use Service to cycle through items. Use Test to select an item and change values/options of selected item. Use EXIT to return to Test Main Menu.

SPEAKER TEST	Check the operation of the speaker output device
FRONT LEFT SPEAKER	Normal if the sound is heard from the left front speaker
FRONT RIGHT SPEAKER	Normal if the sound is heard from the right front speaker
REAR LEFT SPEAKER	Normal if the sound is heard from the left rear speaker
REAR RIGHT SPEAKER	Normal if the sound is heard from the right rear speaker
CENTER SPEAKER	Normal if the sound is heard from the center speaker
WOOFER SPEAKER	Normal if the sound is heard from the woofer speaker
BLAST WOOFER SPEAKER	Normal if the sound is heard from the blast woofer speaker
GIMMICK OUTPUT TEST	Check the operation of the gimmick output device
SEAT VIBRATION	Normal if the seat vibrates when ON
STEP VIBRATION	Normal if the step vibrates when ON
AIR GIMMICK	Normal if the air gimmick can shoot air when ON
P1/P2 Controller VIBRATION	Checks the speaker of the Controller MACHINEGUN is a full auto mode that repeats the launch sound reproduction (24 shots) → reload time OFF → shoot sound reproduction "LASERGUN", "GRENADE" will play the launch sound every other shot, become silent, then launch sound will be played again, then loop
ALL SOUND VOLUME	It is volume setting of all sounds. The volume gets bigger as you approach 20/20 (Default = 15/20. Value Ranges = 1 - 20、 OFF) "SEAT VIBRATION, STEP VIBRATION, AIR GIMMICK, P1 Controller VIBRATION, P2 Controller VIBRATION" are not affected by ALL SOUND VOLUME
ADVERTISE SOUND VOLUME	Sound volume setting of advertisement. The volume will increase as you approach 10/10. (Initial set value: 10/10 set value: 10/10 to 1/10, OFF)
SENSOR VOICE VOLUME	Audio FX volume setting. The volume will increase as you approach 10/10. (Initial set value: 10/10 set value: 10/10 to 1/10, OFF)
WOOFER VOLUME	Volume setting of Woofer. The volume will increase as you approach 10/10. (Initial set value: 10/10 set value: 10/10 to 1/10, OFF)
GIMMICK	Set the volume of the gimmick output device
SEAT VIBRATION	It is the seat vibration setting. The vibration becomes greater as it approaches 10/10. (Initial set value: 10/10 set value: 10/10 to 1/10, OFF)
STEP VIBRATION	It is vibration setting of step. The vibration becomes greater as it approaches 10/10. (Initial set value: 10/10 set value: 10/10 to 1/10, OFF)

AIR GIMMICK	Setting of strength to shoot out air. It gets stronger as it approaches 10/10. (Initial set value: 10/10 set value: 10/10 to 1/10, OFF)
P1/P2 Controller VIBRATION	Vibration setting of the Controller. The vibration becomes greater as it approaches 10/10. (Initial set value: 10/10 set value: 10/10 to 1/10, OFF)

9-9 BACKUP DATA CLEAR

In this menu you can delete the back-up data.

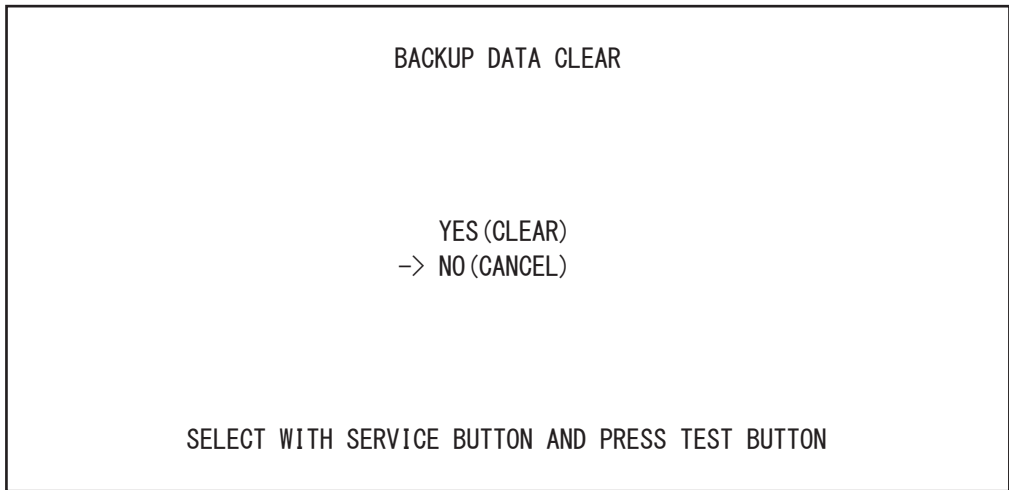

Backup Data Clear Menu

- Use the Service Button to select the item
- Use the Test Button to select the highlighted item
- YES (CLEAR) You will see a confirmation saying "Are you sure?"
Select "YES (CLEAR)" to erase backup data. Press the Test Button to return to the Game Test Menu screen
- NO (CANCEL) - You will return to the Game Test Menu screen without erasing the backup data.
- NO (CANCEL) You will return to the Game Test Menu screen without erasing the backup data.

9-10 ERROR CODES

CAUTION

- If an error code is displayed, arrange to have the issue resolved by maintenance personnel or a qualified individual. Attempting to resolve the issue without knowledge of electronics or components could lead to short circuit, electric shock or risk of fire
- Electronic components on the IC board may be damaged by static electricity of the human body. Take measures such as touching a grounded metal surface before work and discharge static electricity

0912	Display	The graphics board could not continue rendering
	Cause	DVI cable is not connected
	Solution	Connect the DVI cable to the graphic board

0919	Display	DVD Drive is still connected
	Cause	DVD Drive is still connected
	Solution	Remove the DVD Drive

3001	Display	Communication with Controller failed
	Cause	Communication with Controller failed
	Solution	Check the connection of the Controller board

3010	Display	The coin setting is invalid
	Cause	The game cost setting is an unacceptable value
	Solution	Set the value to allow game cost setting from coin setting in system test mode

6401	Display	I/O Board is not recognised
	Cause	I/O Communication with the board failed
	Solution	I/O Check the board connection.

9-11 WARNING DISPLAYS

Warnings can be canceled arbitrarily. Press the Service Button to cancel the warning and return to the Attract Screen.

Warnings are displayed at startup and when returning from the test mode to the game.

Display	Touch type card reader can not be recognized SERVICE BUTTON: Release warning
Cause	Touch type card reader can not be recognized
Solution	Please check the connection of the touch type card reader

Display	LED Communication with the board failed SERVICE BUTTON: Release warning
Cause	LED Communication with the board failed
Solution	LED Check the connection of the control board. Alternatively, connect the USB serial conversion board (USB port)

Display	USB Failed to communicate with the serial board SERVICE BUTTON: Release warning
Cause	USB Failed to communicate with the serial board
Solution	Check the serial conversion board connection (USB port). This warning also occurs even when both the LED control board and the touch type card reader are not connected

10 VIDEO DISPLAY

CAUTION

The LCD display screen is adjusted prior to leaving the factory. Avoid any unnecessary adjustment.

IMPORTANT

- If the adjustment method in this manual does not resolve the problem, contact the customer service number in this manual or your supplier.
- Do not stick tape, stickers or anything else onto the screen. Any kind of adhesive may damage the surface of the screen.

10-1 GENERAL DESCRIPTION

This specification applies to the 54.6 inch Color TFT-LCD Module P550HVN02.0. This LCD module has a TFT active matrix type liquid crystal panel 1,920x1,080 pixels, and diagonal size of 54.6 inch.

This module supports 1920x1080 mode. Each pixel is divided into Red, Green and Blue sub-pixels or dots which are arranged in vertical stripes. Gray scale or the brightness of the sub-pixel color is determined with a 10-bit gray scale signal for each dot.

The P550HVN02.0 has been designed to apply the 10-bit 2 channel LVDS interface method. It is intended to support displays which have high brightness, wide viewing angle, high color saturation, and high color depth.

* General Information

Items	Specification	Unit	Note
Active Screen Size	54.6	Inch	
Display Area	1209.6(H) x 680.4(V)	mm	
Outline Dimension	1235.6(H) x 706.4(V) x 25.5(D)	mm	1
Driver Element	a-Si TFT active matrix		
Display Colors	10 bit (8bit+FRC), 1073.7M	Colors	
Number of Pixels	1,920x1080	Pixel	
Pixel Pitch	0.21 (H) x 0.63(W)	mm	
Pixel Arrangement	RGB vertical stripe		
Display Operation Mode	Normally Black		
Display Orientation	Landscape/Portrait Enable		
Surface Treatment	AG		Haze = 11%

10-2 CLEANING THE SCREEN

⚠ CAUTION

- Since the LCD display screen is susceptible to damage, pay careful attention to its handling. When cleaning, refrain from using water or volatile chemicals.
- Do not climb onto the control panel. This could lead to injuries, such as bumping your head.
- When reaching across the control panel to clean the screen there is a risk of hurting your shoulder or arm. Use a mop with a non-feathery, soft, dry cloth mop head and wipe the surface of the screen.

When the screen surface becomes dirty, clean it by using a soft cloth such as gauze. When water, and volatile chemicals such as benzene, thinner, etc., spill on the screen surface, it may be subject to damage. Therefore, do not use them.

Also, since the surfaces are susceptible to damage, refrain from rubbing them with a hard material or using a duster. If the screen is especially dirty, call in a professional cleaner.

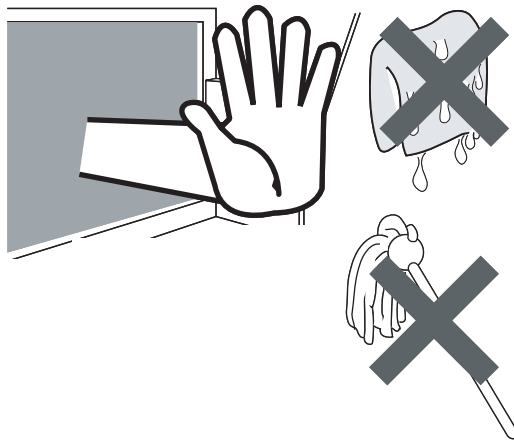

FIG. 10-1

11 CONTROLLER UNIT

WARNING

- When working with the product, be sure to turn the power off. Working with the power on may cause an electric shock or short circuit.
- Be careful not to damage the wires. Damaged wires may cause an electric shock, short circuit or present a risk of fire.
- Do not touch any parts that are not specified in these directions. Touching unspecified locations may lead to electric shock or cause short circuits.
- This work should be performed by site maintenance personnel or other skilled professionals. Work performed by non-technical personnel can cause a severe accident such as an electric shock.
- Exercise due caution in performing soldering procedures. If soldering iron is handled carelessly, there could be fires or burns.
- Proceed very carefully when heating thermal contraction tube. Careless operations can result in fires or burns.

CAUTION

- When fastening plastic parts, be careful not to tighten screws and nuts excessively. Otherwise parts may be damaged, resulting in injuries from fragments, etc.
- Be careful not to get hand or finger caught when removing or attaching the parts.
- Disconnection and connection of connectors will be performed within the narrow cabinet space. Take due care not to scratch or otherwise injure yourself.
- Take care when carrying the removed Control Units. Such heavy lifting carries a risk of injury to back or shoulders.

IMPORTANT

- After the volume has been replaced, be sure to set the volume value on the test mode calibration screen and the input test screen and check variations in the volume value.
- After adjusting or replacing a microswitch, always check ON/OFF of the switch on the input test screen of the test mode.
- Handle parts inside the Control Unit very carefully. Be especially careful to avoid damage, deformation or loss of these parts. If any one of these parts is lost or defective, it can result in damages and/or faulty operations.

If the operability of the Control Unit is unsatisfactory, or if settings on the test mode calibration screen are ineffective, the problem could be a defective mechanism, displacement of the position where volume or microswitch has been fastened, or malfunctioning of volume or microswitch.

Carry out the following procedure to replace Control Unit or microswitch. Also be sure to grease the mechanical components of the Control Unit once every 3 months.

11-1 REMOVING THE CONTROLLER

Tools required for work

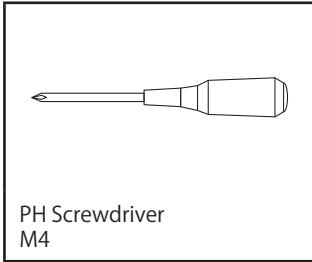

- 1 Turn power OFF
- 2 Remove 4 screws and remove the Holder Lid

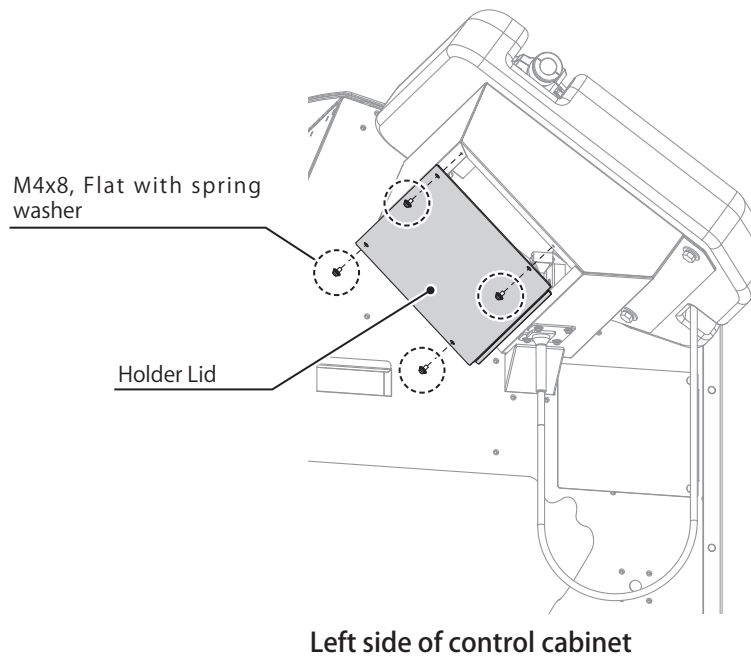

- 3 Unplug the connector

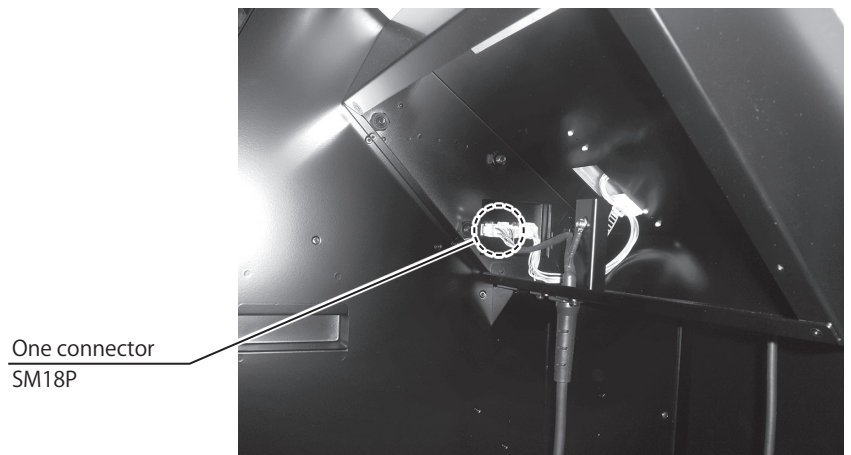

-
- 4** Remove the four screws and remove the Cable Bracket
When installing, make sure that the position of the notch is on the LCD monitor side

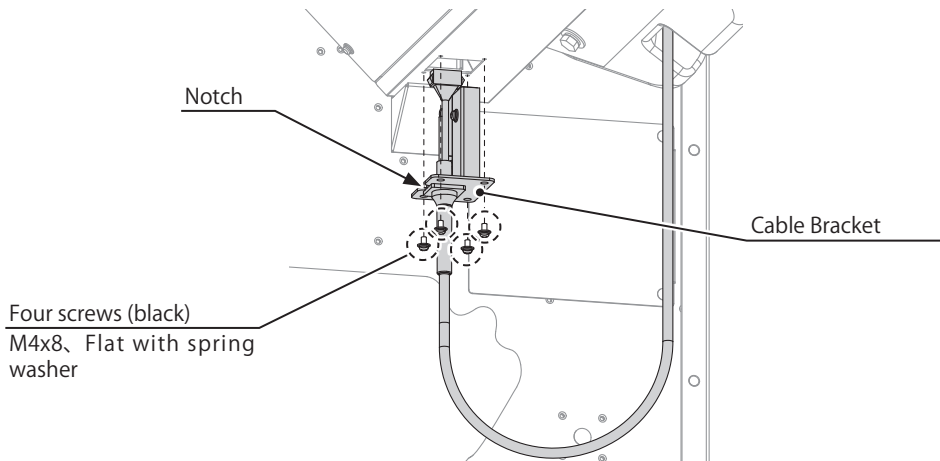

-
- 5** Remove one screw and remove the cable bracket from the Controller
When installing, refer to "How to attach cable bracket" below

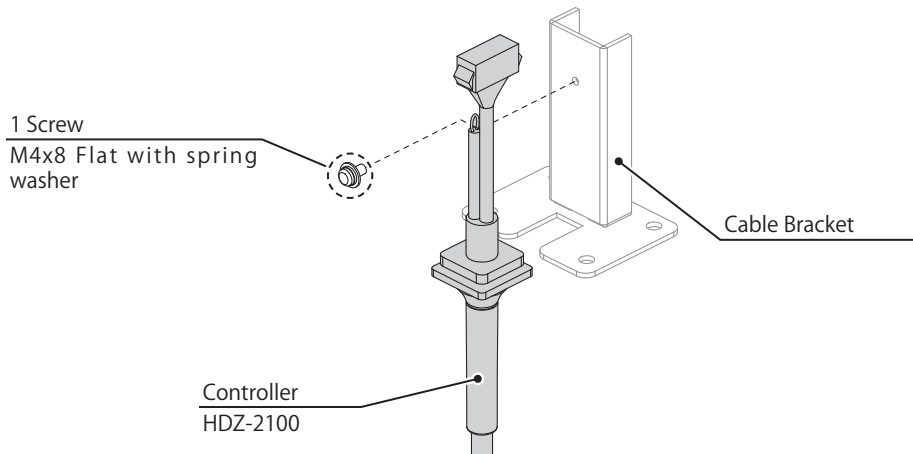

How to attach the cable bracket

- 1 Place the Controller as shown so that there is no twist of the cable

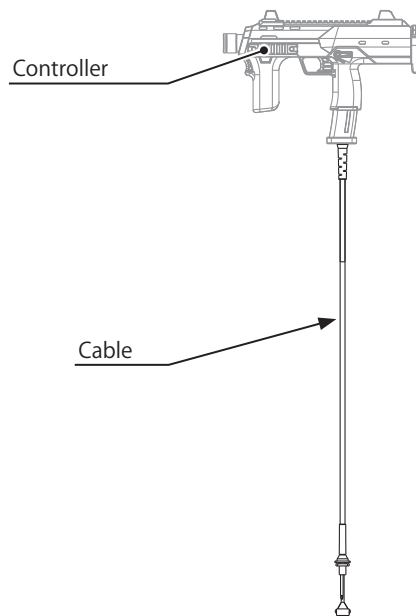

- 2 Plug the cable bracket into the cable. Please refer to the figure below and pay attention to the installation direction

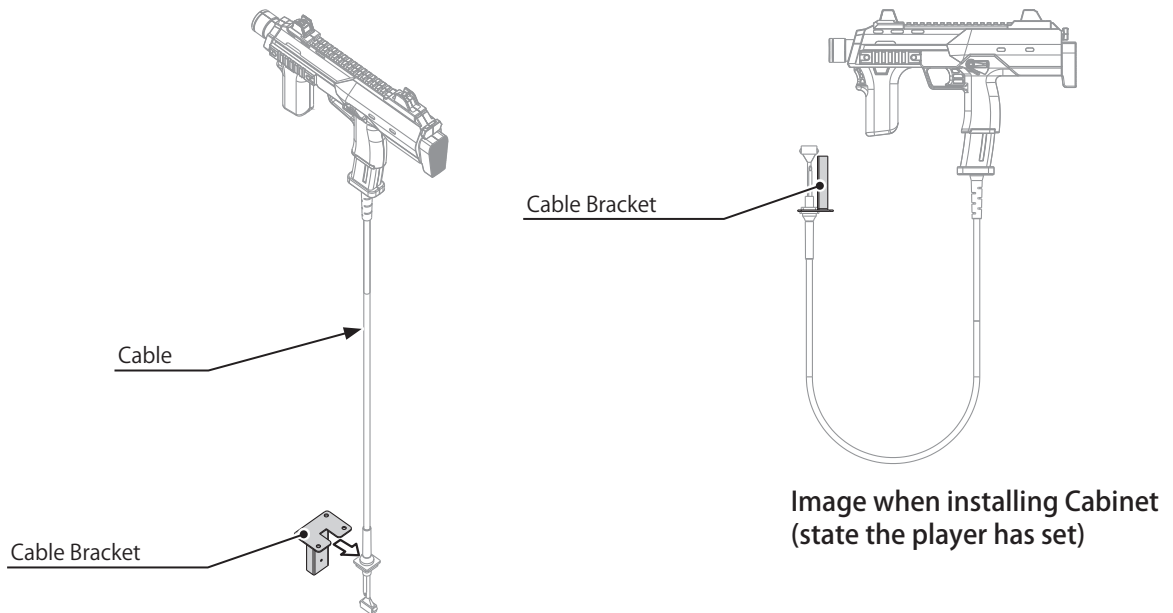

11-2 REPLACING THE CONTROLLER VIBRATION UNIT

CAUTION

Immediately after turning off the power supply, do not touch the Controller Vibration Unit as it may still be hot.

Tools required

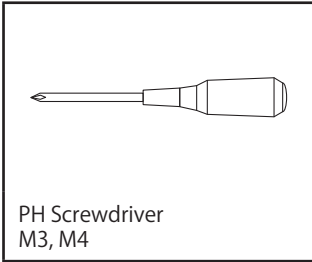

1 Refer to "11-1" and remove the Controller in the same procedure

2 Remove 16 screws and remove Cover R.
When installing, please pay attention to the direction of the select lever

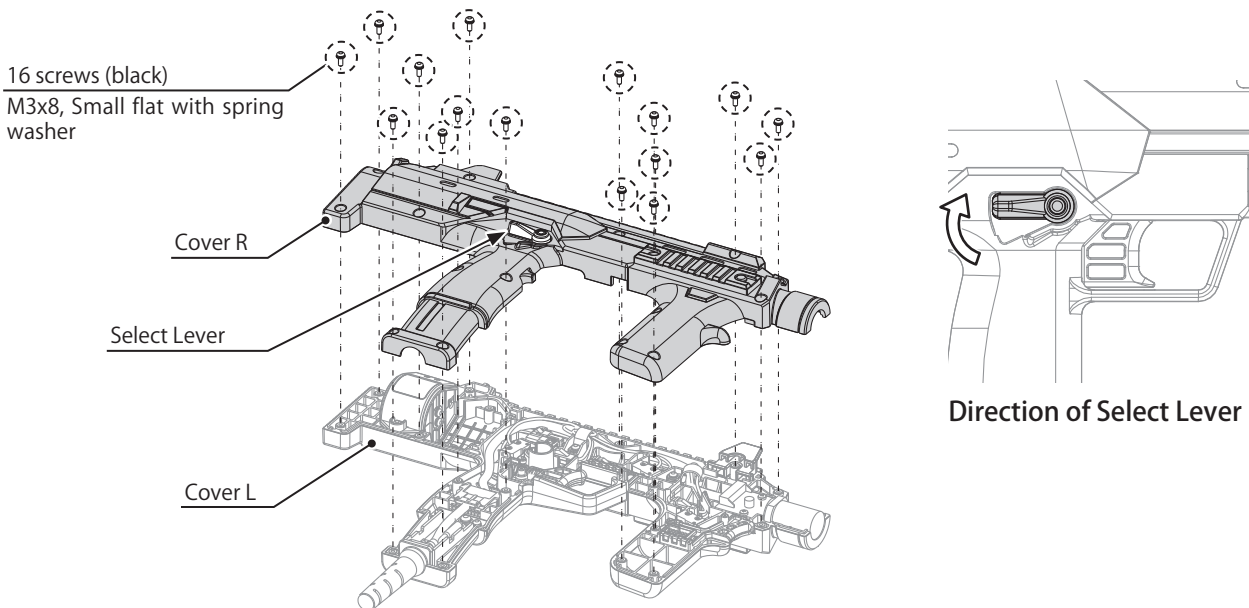

3 Unplug one connector
When connecting, wire the wiring as shown below:

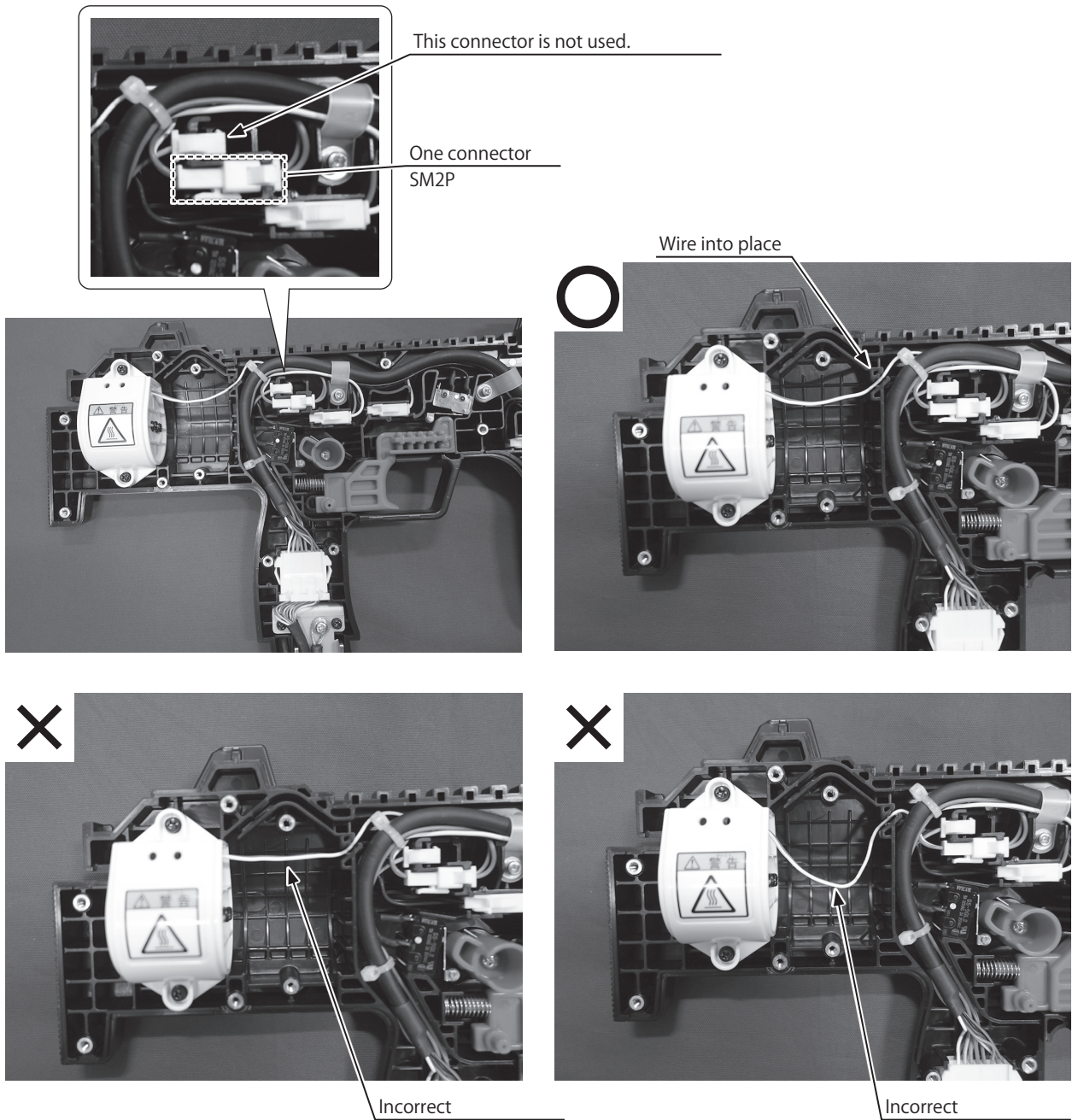

4 Remove the 2 screws and remove the Vibration Unit cover

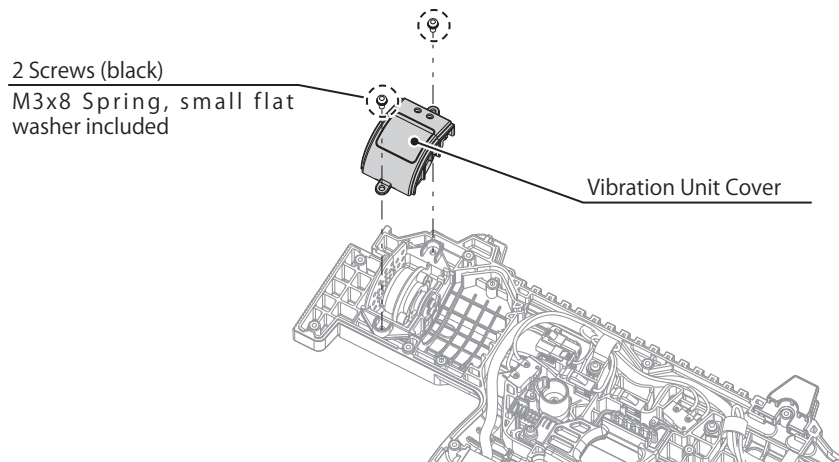

5 Remove the Vibration Unit

Vibration Unit

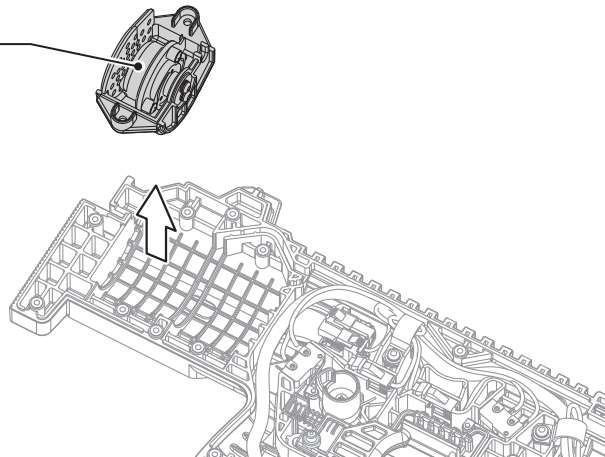

6 Remove the 2 screws and remove the Controller Vibration Unit. When installing, make sure that wiring of Controller Vibration Unit is on top. When checking periodically, please check whether there is loose screw

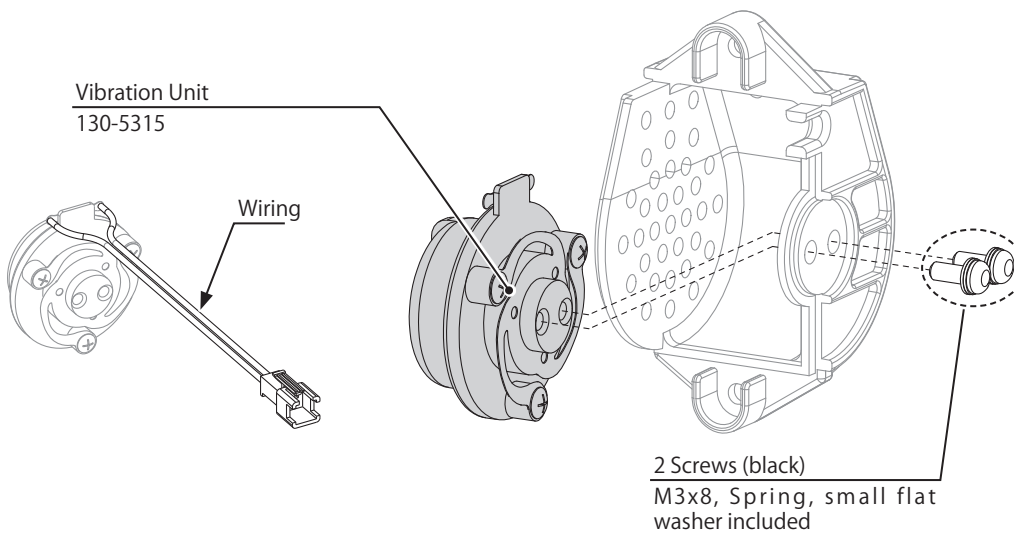

7 Please refer to steps 1 to 6, install the new Controller Vibration Unit in reverse order and reassemble. Be careful not to overtighten the screw

8 Refer to manual sections "INPUT TEST" and "OUTPUT TEST" and check the operation of each device

9 Please refer to manual section "CONTROLLER ADJUSTMENT" and adjust

11-3 REPLACING MICROSWITCH

Tools Required

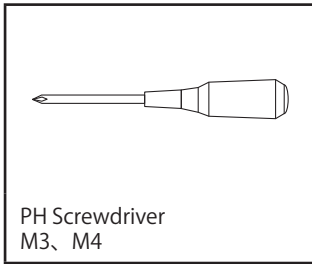

Inside the Controller there are microswitches for Main Trigger, Sub Trigger, and Select Lever

1 Refer to "11-1" and remove the Controller in the same procedure

2 Remove 16 screws and remove Cover R.
When installing, pay attention to the direction of the select lever

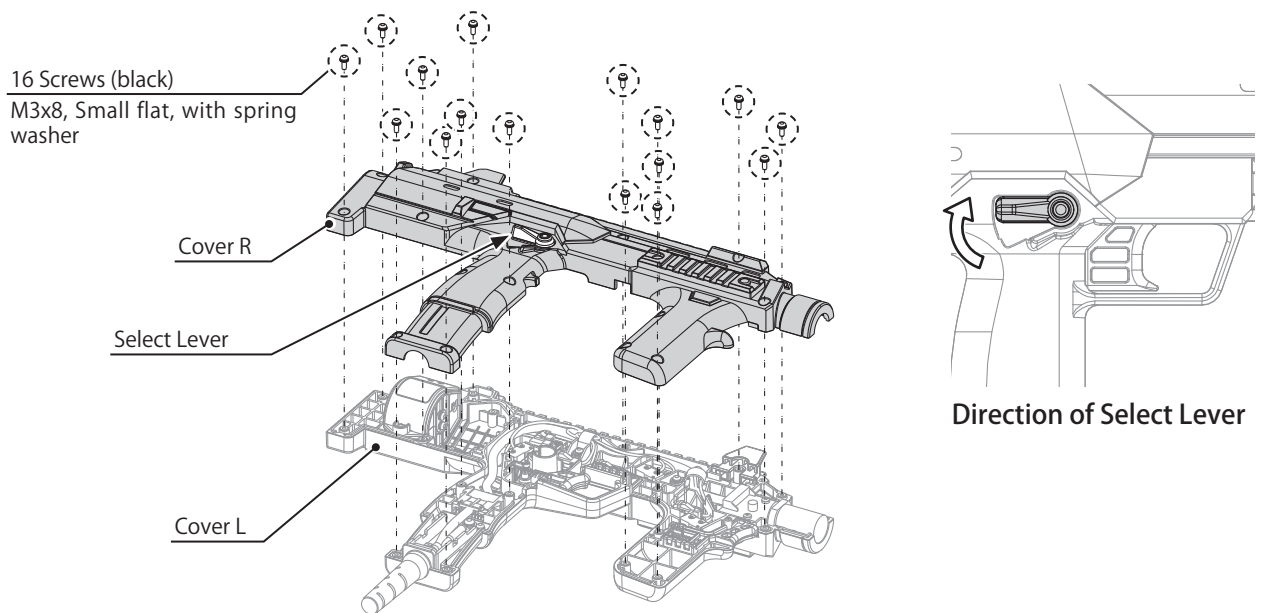

3 Unplug the connector of the microswitch that is to be replaced

One connector
XA2P (For main trigger)

One connector
XA2P (For select lever)

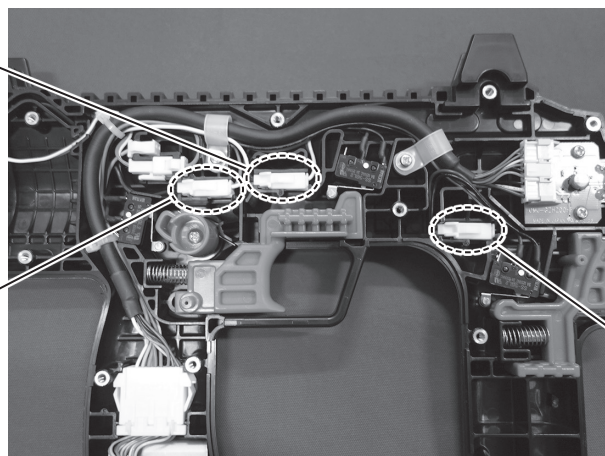

One connector
XA2P (For sub trigger)

4 Remove the Microswitch to be replaced from the Cover L

Micro Switch (for Select Lever)
509-6469

Micro Switch (for Main Trigger)
509-6469

Micro Switch (for Sub Trigger)
509-6469

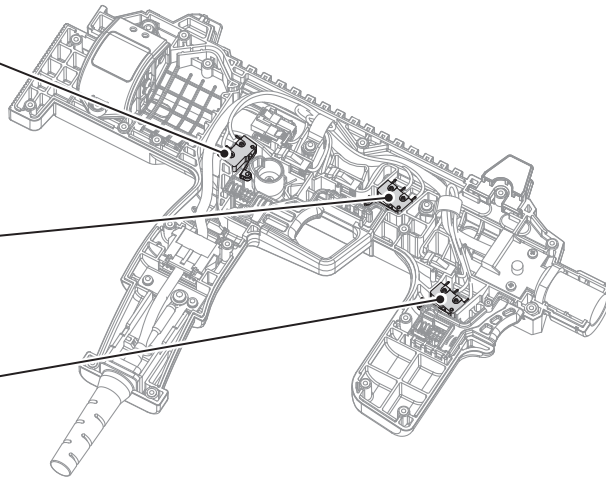

5 Refer to steps 1 to 4, install the new Microswitch in reverse order and reassemble. Be careful not to overtighten the screw

6 Refer to manual sections "INPUT TEST" and "OUTPUT TEST" and check the operation of each device

7 Please refer to manual section "Controller ADJUSTMENT" and adjust

11-4 CHANGE SENSOR UNIT

Tools Required

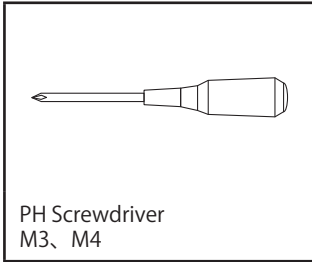

1 Refer to "11-1" and remove the Controller in the same procedure

2 Remove 16 screws and remove cover R.
When installing, please pay attention to the direction of the Select Lever

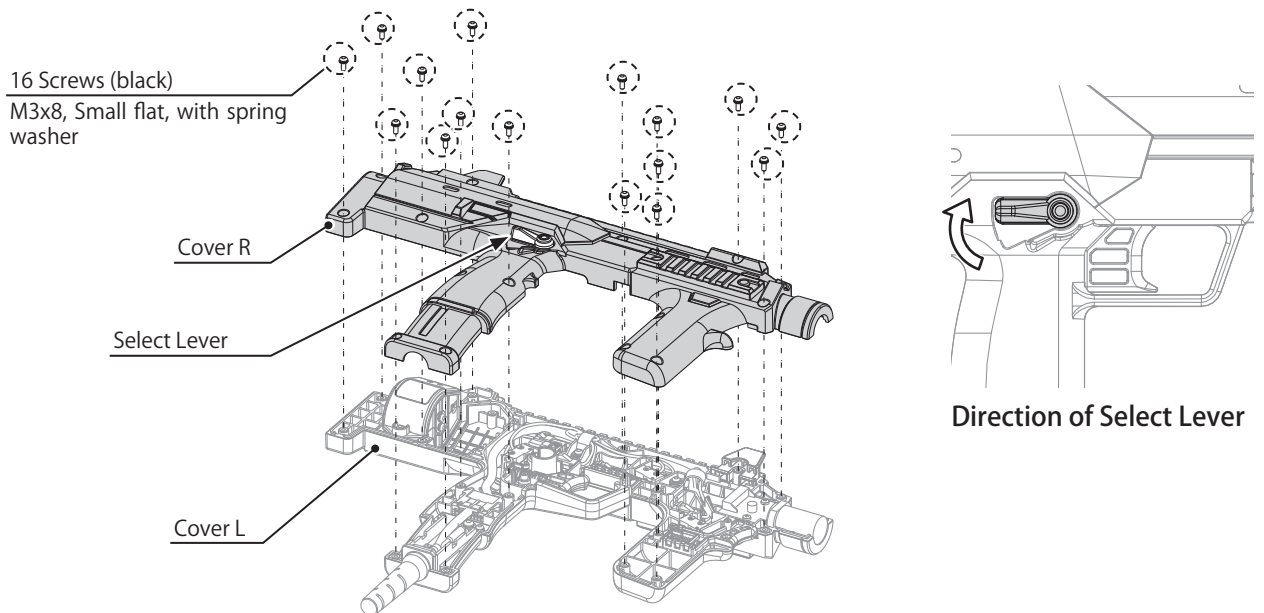

3 Lift the Sensor Unit and pull out connector

Sensor Unit
GLG-2130X

One Connector
XA9P

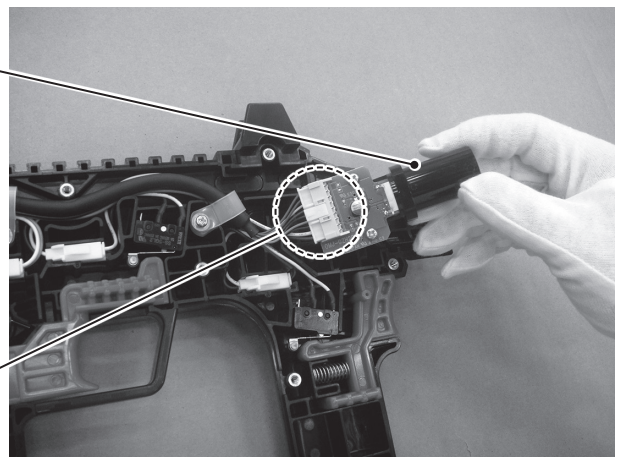

4 Refer to steps 1 to 3, install the new Sensor Unit in reverse order and reassemble. Be careful not to overtighten the screws.

5 Refer to manual sections "INPUT TEST" and "OUTPUT TEST" and check the operation of each device

6 Please refer to manual section "Controller ADJUSTMENT" and adjust

11-5 REPLACING THE CONTROLLER CABLE

Tools Required

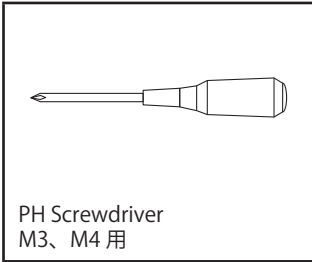

1 Refer to "12-2" and remove the Controller in the same procedure

2 Remove 16 screws and remove Cover R. At this time, lower the Cover L.
When installing, please pay attention to the direction of the Select Lever

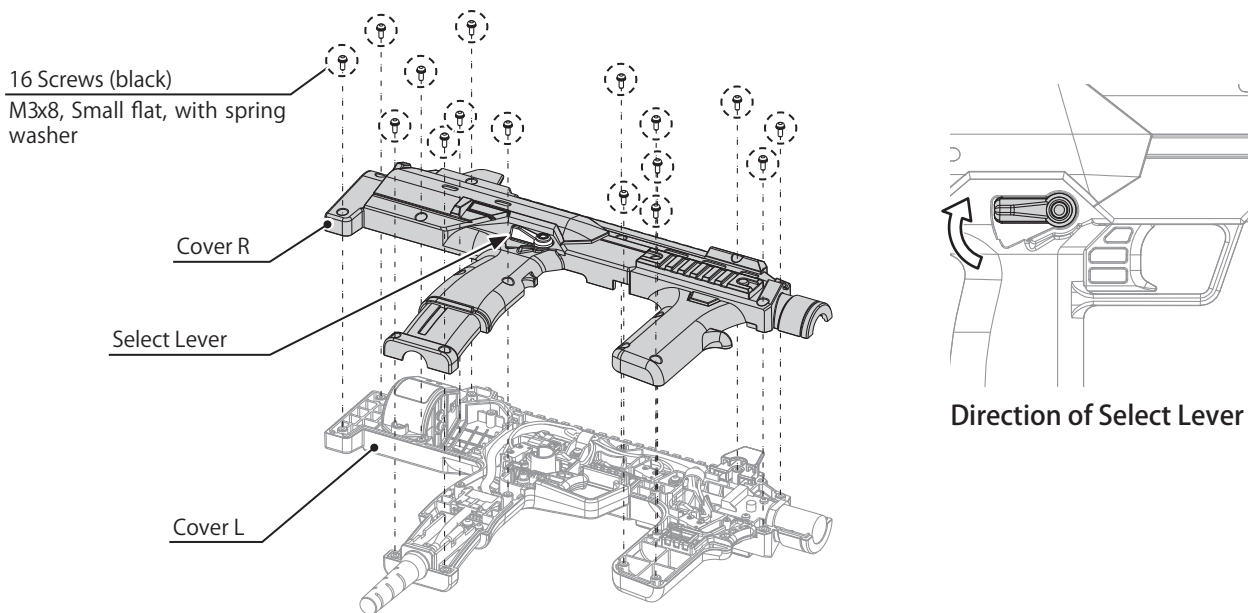

3 Remove 1 screw

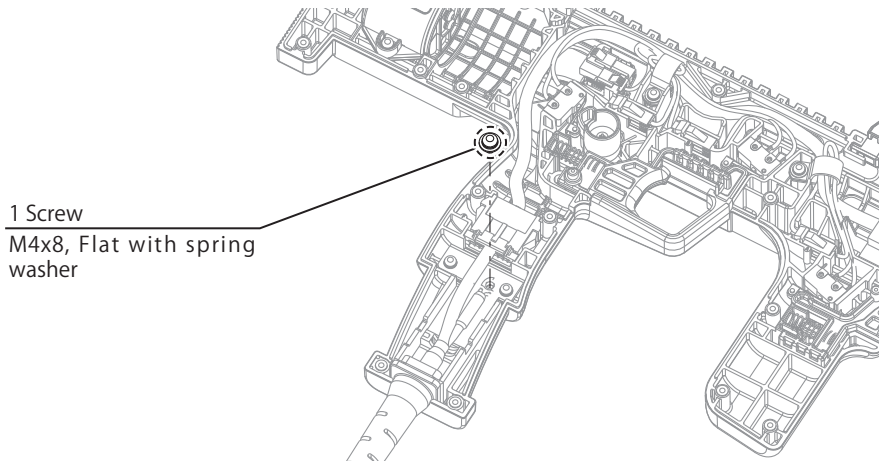

4 Lift the Controller cable and disconnect connector

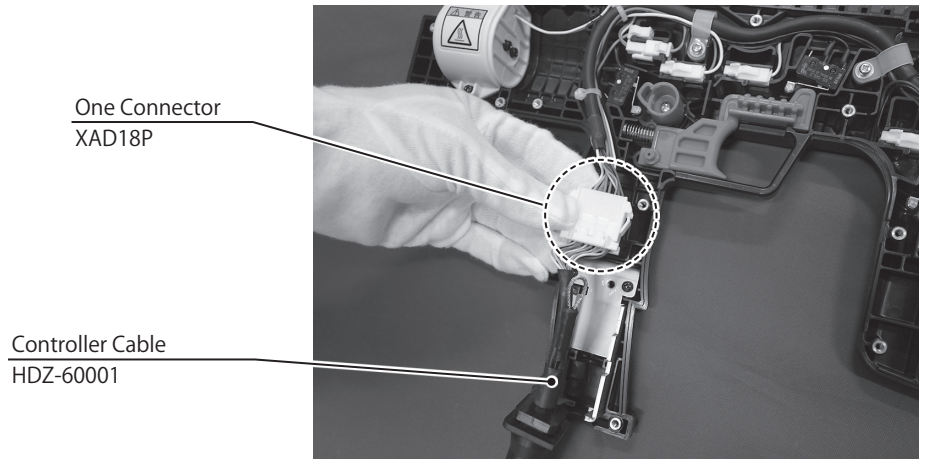

5 Refer to steps 1 to 4, install the new Controller cable in reverse order and reassemble. Be careful not to overtighten the screw

11-6 CONTROL PANEL BUTTON SWITCH CHANGE

Tools Required

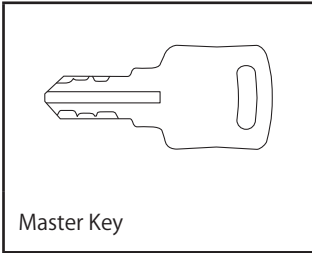

1 Turn off the power switch

2 Release with the Master Key and open the Control Panel.
At this time, open the Control Panel until the stay is locked.
When closing the Control Panel, please open it once, unlock it and close it

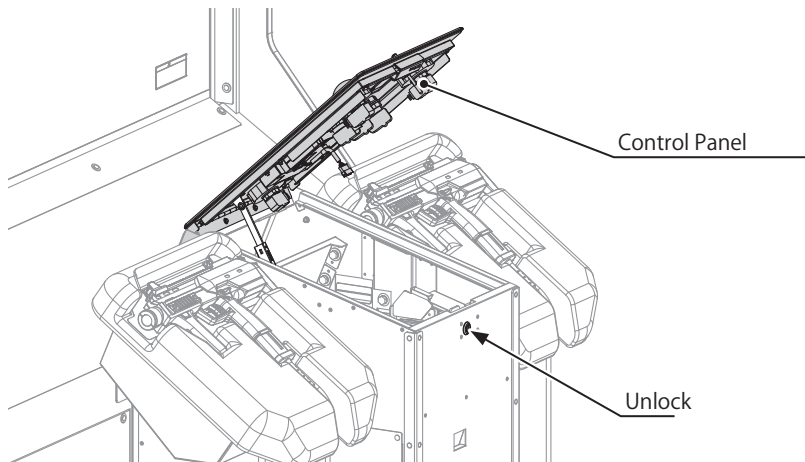

3 Unplug the connector of the switch you want to replace

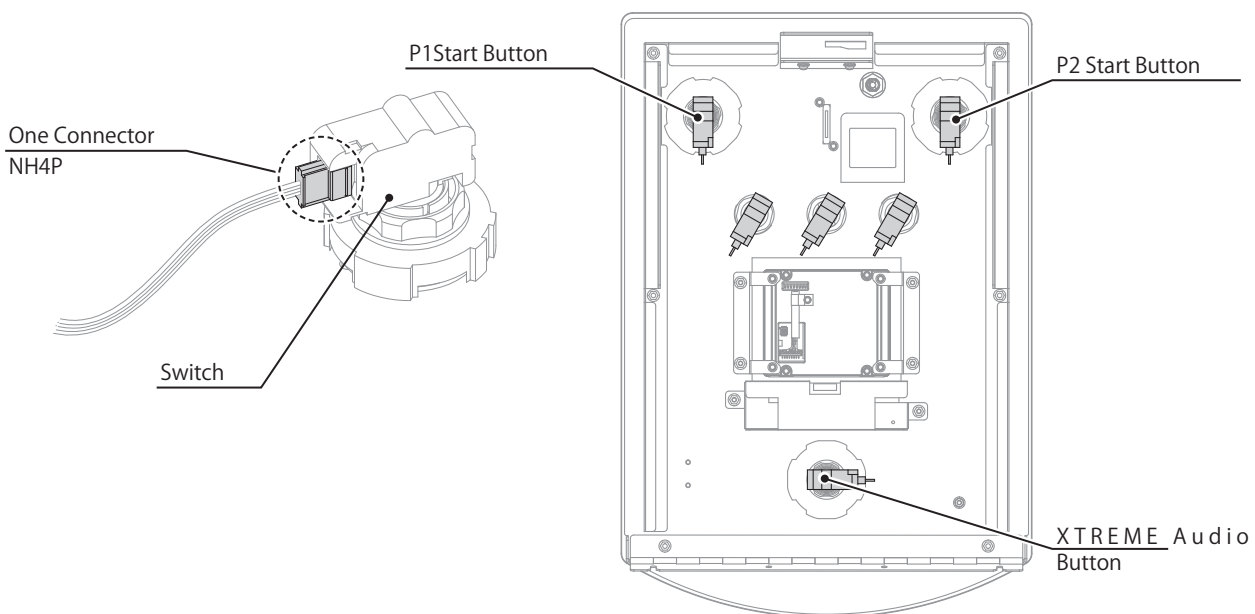

4 Turn counterclockwise 45° to unlock and remove the switch

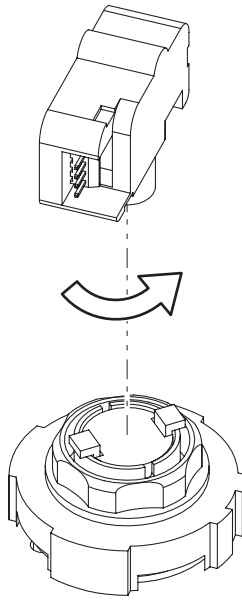

5 Unplug LED

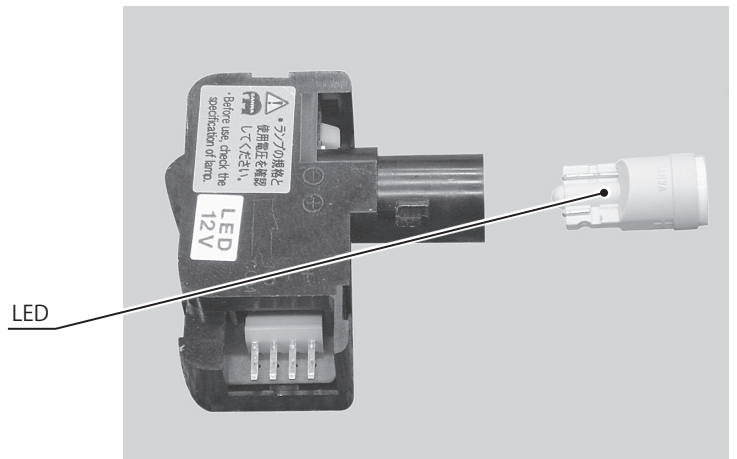

6 Attach LED removed in step 5 to the new switch. Attach "+" marked on the LED and switch.

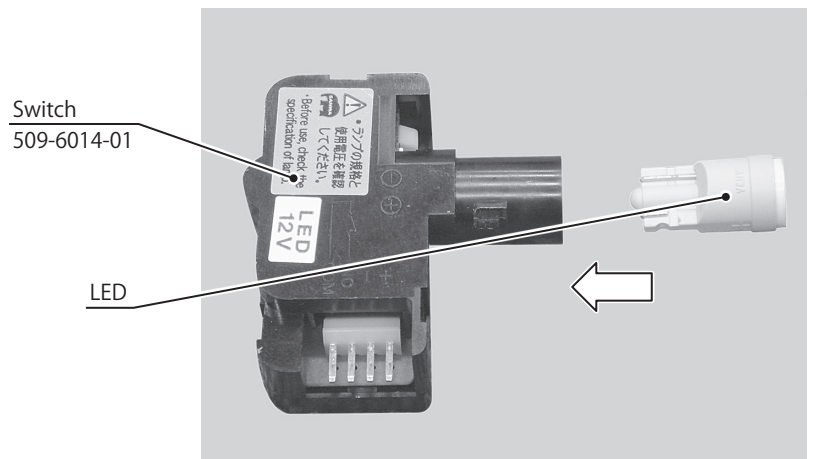

7 Refer to steps 2 to 4, install the new switch in reverse order and reassemble

12 COIN HANDLING

Handling the Coin Jam

If the coin is not rejected when the REJECT button is pressed, open the coin chute door and open the selector gate. After removing the jammed coin, put a normal coin in and check to see that the selector correctly functions.

12-1 CLEANING THE COIN SELECTOR

STOP IMPORTANT

- Remove and clean smears by using a soft cloth dipped in water or diluted chemical detergent and then squeezed dry.
- Never apply machine oil, etc. to the Coin Selector.
- After cleaning the Coin Selector, insert a regular coin in the normal working status and ensure that the selector correctly functions.

The Coin Selector should be cleaned once every 3 months.
When cleaning, follow the procedure below:

- 1 Turn the power for the machine OFF. Open the Coin Chute Door
- 2 Remove the Coin Selector from the Coin Chute Door
- 3 Open the gate and dust off by using a soft brush (small soft Paint Brush, etc.)

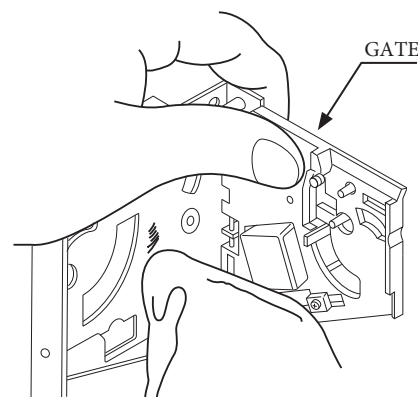

12-1 FIG 1

CLEANING THE COIN SELECTOR (MECHANICAL).

1 Remove and clean smears by using a soft cloth dipped in water or diluted chemical detergent and then squeezed dry.

2 Remove the CRADLE. When removing the retaining ring (E ring) be very careful so as not to bend the rotary shaft.

3 Remove stain from the rotary shaft and shaft receiving portions by wiping off with a soft cloth, etc.

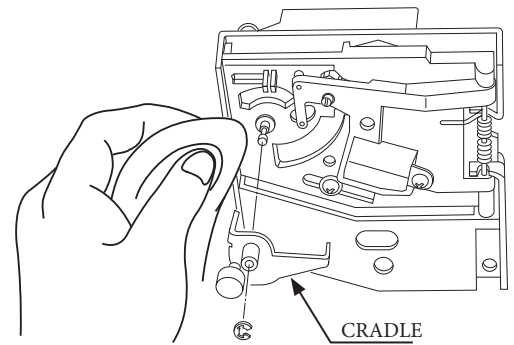

12-1 FIG 2

4 After wiping off as per previous step, further apply a dry cloth to completely dry the Coin Selector.

Coin Insertion Test

Once every month, when performing the Coin SW Test, simultaneously check the following:

Does the Coin Meter count satisfactorily?

Does the coin drop into the cashbox correctly?

Is the coin rejected when inserted while keeping the REJECT Button pressed down?

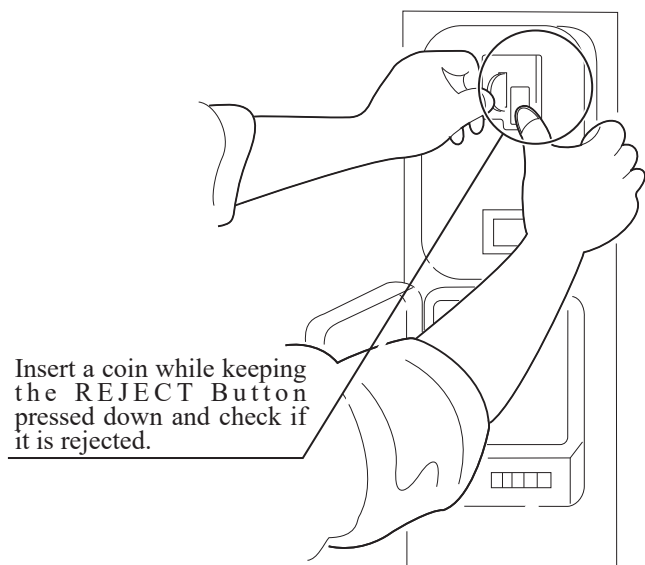

12-1 FIG 3

CLEANING THE COIN SELECTOR (SR3 / NRI)

- 1** Remove and clean smears by using a damp soft cloth dipped in water. DO NOT use any diluted chemical detergent or cleansing agent as this will impair the workings of the component.

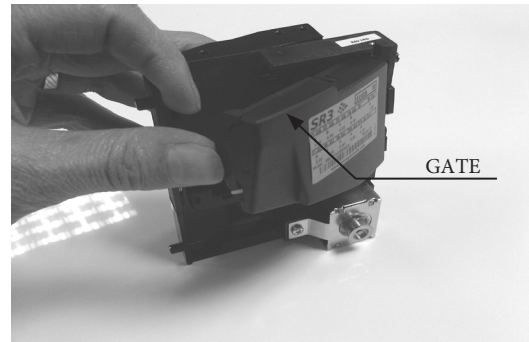

- 2** Open the reject gate to gain access to the rundown path.



- 3** Remove the dirt and stains from the runway by wiping off with a soft damp cloth.



- 4** After wiping off as per previous step, further apply a dry cloth to completely dry the coin Selector.

12-2 FAULT FINDING

Fault Finding

The following information is presented for customers' guidance in rectifying a fault but does not cover all possible causes.

All acceptors with electronic faults should be returned to an approved service centre for repair.

SYMPTOM	INVESTIGATE	POSSIBLE CAUSE
Acceptor does not work (all coins reject)	Connector	Poor Contact
		Loose Wire
	Power Supply	Not switched on
		Incorrect voltage
		Inadequate current
		Rise time too slow
	Inhibit all inputs	Acceptor Inhibited
	Accept gate	Gate not free or dislocated
	Accept channel	Obstruction
	Reject gate	Not fully closed
	LED on rear cover RED	EEPROM chksm error
SR Sensor fault		
Credit opto fault		
Credit sensor blocked		
	Reject lever pressed	
LED on rear cover YELLOW	Reinstall power	
Poor Acceptance	Power Supply	Voltage less than 10v (Voltage drops when coil engages)
	Accept gate	Gate jam or dislocated
	Connector	Loose
	Coin rundown	Dirty
	Bank Select	Both banks enabled
Coin stick or jam in acceptor	Accept channel	Acceptor dirty or may have some damage
	Accept gate	
	Reject gate	
A true coin type rejects	Label	Coin not programmed
No accept signal	Connector	Loose or broken wire
	Accept channel	Path dirty or obstructed

12-3 ADJUSTING THE PRICE OF PLAY (EXCEL)

STOP IMPORTANT

- The price of play is determined by the configuration of switches located on either the EXCEL or VTS board. The type of board used is determined by product location. Switch settings for both types of board remain the same.

This product comes equipped with a Crane NRI Coin Acceptor. To adjust the price of play ALL CREDIT SETTINGS are adjusted via the EXCEL CREDIT BOARD.

IMPORTANT!

The CREDIT SETTINGS within the SYSTEM TEST MODE must be set to 1 coin 1 credit to allow the CREDIT BOARD to function correctly.

The CREDIT BD has a built in accumulator. This is controlled by 2 DIL Switches. These allow the operator to select the price of play, type of coin acceptor and region.

EXCEL Credit Board

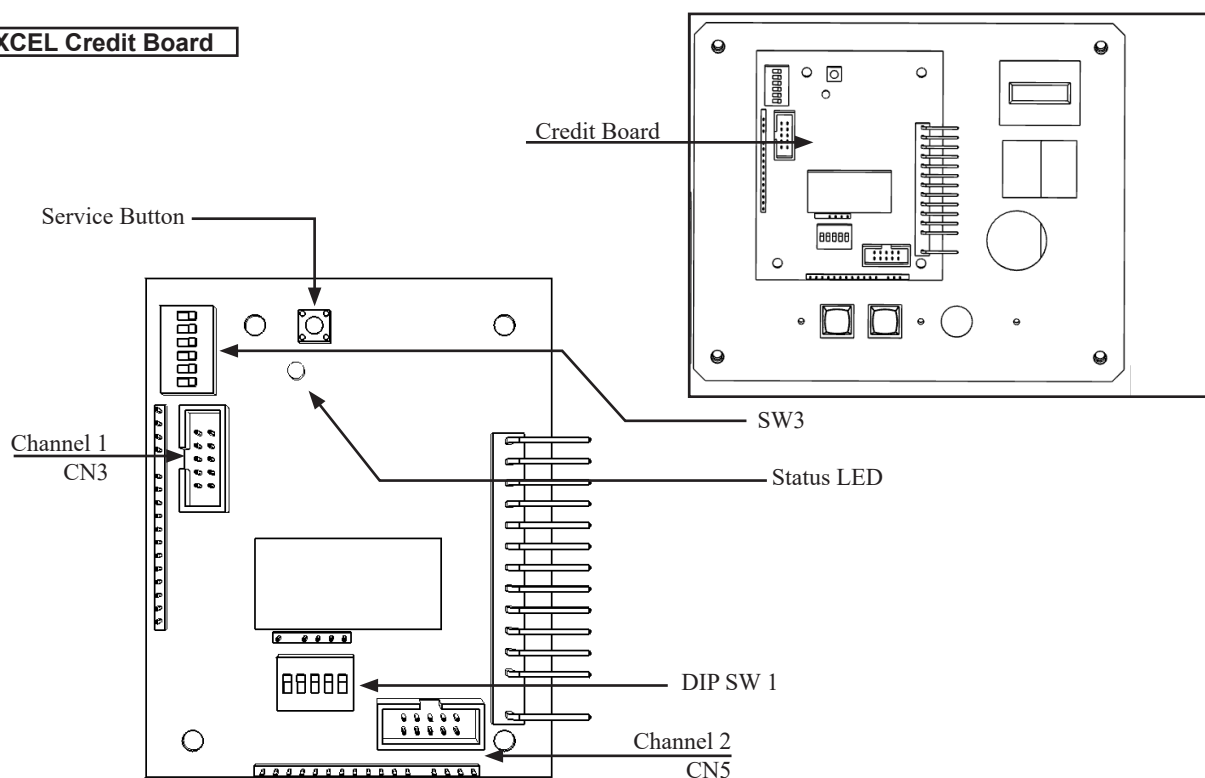

DIP SW3 (Regional Settings)

Adjust these switches to specify the type of Coin Acceptor used and currency.

Default = SW1&SW2 ON - SR3/NRI in parallel mode, Sterling.

SERVICE BUTTON

Provides a SERVICE CREDIT when pressed

Status LED

Flashes when functioning.

CHANNEL 1

To Coin Acceptor (SR3 TYPE.)

DIP SW1 (credit settings)

Adjust to required price of pay.

VOL CONTROL

MAIN VOLUME ADJUSTMENT (FRONT SPEAKERS)

12-4 ADJUSTING THE PRICE OF PLAY (VTS)

This product comes equipped with a Crane NRI Coin Acceptor. To adjust the price of play ALL CREDIT SETTINGS are adjusted via the VTS CREDIT BOARD.

IMPORTANT!

The CREDIT SETTINGS within the SYSTEM TEST MODE must be set to 1 coin 1 credit to allow the CREDIT BOARD to function correctly.

The VTS BD has a built in Credit Board. This is controlled by 2 DIL Switches. These allow the operator to select the price of play, type of coin acceptor and region.

VTS Board

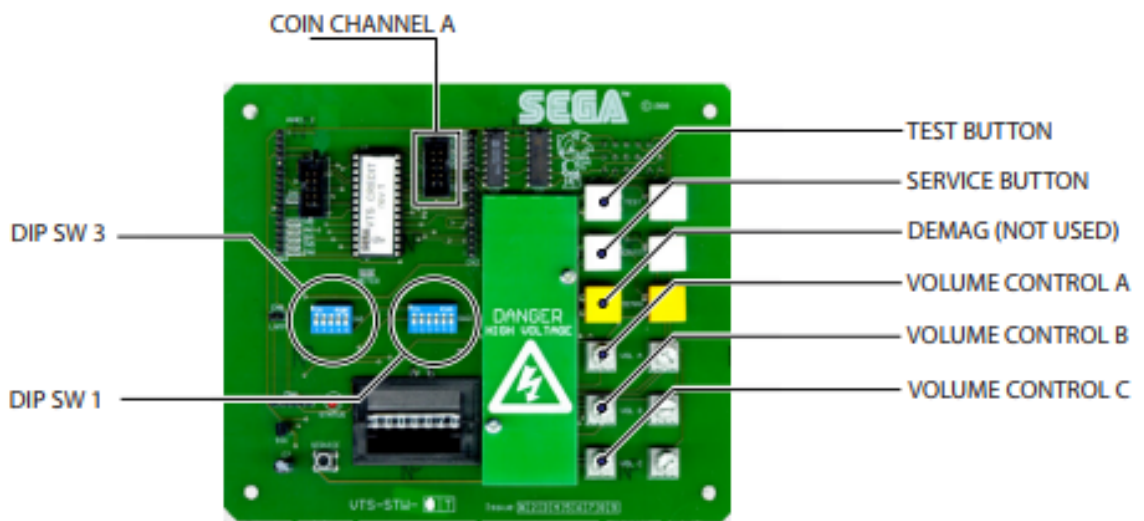

DIL SW3 (Regional Settings)

Adjust these switches to specify the type of Coin Acceptor used and currency.

Default = SW1&SW2 ON - SR3 in parallel mode, Sterling.

TEST BUTTON	Provides access to the TEST MENU when pressed.
SERVICE BUTTON	Provides a SERVICE CREDIT when pressed
Status LED	Flashes when functioning.
CHANNEL A	To Coin Acceptor (SR3 TYPE.)
DIL SW1 (credit settings)	Adjust to required price of pay.
DEMAG	NOT USED
VOL CONTROL A	MAIN VOLUME ADJUSTMENT (FRONT SPEAKERS)
VOL CONTROL B	SECONDARY VOL ADJUSTMENT (GUN SPEAKERS)
VOL CONTROL C	NOT USED

13 PERIODIC INSPECTION

The items listed below require periodic check and maintenance to retain the performance of this machine and to ensure safe business operation.

When handling the controller, the player will be in direct contact with it. In order to always allow the player to enjoy the game, be sure to clean it regularly. Also, it is advisable to provide wet tissues, etc. available for player use.

WARNING

- **Every 6 months check to see if power cords are damaged, the plug is securely inserted, no dust has accumulated between the socket outlet and the power plug, etc. Using the product with accumulated dust in the interior may cause fire or electric shock.**
- **Never use a water jet, etc. to clean the inside or outside of the cabinet. If wetness occurs for any reason, do not use the product until it has completely dried.**
- **Once a year, request the office shown on this manual or the dealer from whom the product was originally purchased to perform the internal cleaning. Using the product with accumulated dust in the interior may cause fire or other accidents.**
- **Note that you are liable for the cost of cleaning the interior parts.**
- **There is the danger of accidents involving electrical shorts circuits or fire caused by factors such as the deterioration of insulation in electrical and electronic equipment over time. Check that there are no abnormalities such as odours from burning.**

14 TABLE 01 PERIODIC INSPECTION TABLE

PERIOD	ITEM	DESCRIPTION	REFERENCE
As appropriate	Cabinet Surface	Cleaning	As Below
	Control Unit Surface		
Daily	Cabinet	Confirm Adjusters Contact Floor	
Weekly	Control Unit	Aim Test	
	LCD	Screen Cleaning	
		Screen Alignment	
Monthly	Front Cabinet	Speaker Volume	
	Controller Cabinet	Check Input Devices	
		Check Output Devices	
	Controller Unit	Check Speaker Volume	
		Speaker Inspection	
		Check Each Input Device	
	LED board	LED Inspection	
	Coin Selector	Coin Path Inspection	
Coin Insertion Test			
Every 3 Months	Coin Selector	Cleaning	
1 Year	Ringwide	Cleaning	
	Power Cables	Inspection / Cleaning	
	Cabinet Interior	Cleaning	

Cleaning the Cabinet Surfaces

When the cabinet surfaces are badly soiled, remove stains with a soft cloth dipped in water or diluted (with water) chemical detergent and squeezed dry. To avoid damaging surface finish, do not use solvents such as thinner, benzine, etc. other than ethyl alcohol, or abrasives, bleaching agent and chemical dustcloth.

Some general-purpose household, kitchen and furniture cleaning products may contain strong solvents that degrade plastic components, coatings, and print. Before using any cleaning product, read the product's cautionary notes carefully and test the product first on a small area that is not highly visible.

14 TROUBLESHOOTING

14-1 TROUBLESHOOTING (WHEN NO ERROR MESSAGE IS SHOWN)

WARNING

- This work should be performed by site maintenance personnel or other skilled professionals. Work performed by non-technical personnel can cause a severe accident such as an electric shock. If there are no site maintenance personnel or other skilled professionals available, turn off the power immediately and contact the office given in this manual or from point of purchase.
- When working with the product, be sure to turn the power off. Working with the power on may cause an electric shock or short circuit accident.
- In order to prevent electric shock and short circuit, be sure to turn power off before performing work.
- Be careful so as not to damage wirings. Damaged wiring can cause electric shock or short circuit.
- After removing the cause of the functioning of the Circuit Protector, reinstate the Circuit Protector. Depending on the cause of the functioning, using the Circuit Protector as is without removing the cause can cause generation of heat and fire hazard.
- In the event that a problem cannot be resolved by employing the procedures listed in this Manual, be sure to request service from the office shown in this Manual or the dealer from whom the product was originally purchased. Attempts to employ procedures other than those specified in this Manual can cause electrical shock, shorting, or fire.
- In the event of a problem that is not described here, be sure to contact the office shown on this Manual or the dealer from whom the product was originally purchased. Careless attempts at repair can result in electrical shock, shorting, or fire.

IMPORTANT

- If an error message is displayed, identify the cause and without delay take the appropriate countermeasures. Leaving the error unaddressed could result in a breakdown.
- If a problem occurs, first inspect the connection of any wiring connectors.
- Static electricity from your body may damage some electronic devices on the IC board. Before handling any IC board, touch a grounded metallic surface so that static electricity is discharged.

If a problem occurs, first check to make sure that the wiring connectors are properly connected.

15 TABLE 01

PROBLEM	CAUSE	COUNTERMEASURES
When the Main SW is turned ON, the machine is not activated.	The power is not ON	Firmly insert the plug into the outlet
	Incorrect power source/voltage	Make sure that the power supply/voltage are correct
	The Fuse on the AC Unit has blown due to momentary over current	After eliminating the cause of overload, replace the specified rating fuse
	The Fuse of the Connect Board has blown due to momentary over current	After eliminating the cause of overload, replace the specified rating fuse
No sound is generated from the speakers	Volume not correctly adjusted	Adjust the sound volume (see chapter 9)
	Game Bd or Amplifier malfunction	Call service dept mentioned in this manual
LCD colour incorrect	Screen not correctly adjusted	Adjust the screen (see chapter 11)
	VGA cable malfunction	Replace VGA cable
	LCD failure	Call service dept mentioned in this manual
The controller line of sight is not acceptable	Sights are not aligned due to changes in the surrounding environment	Re-align the sight settings (see chapter 9)
	Sight LED board malfunction.	Check LED bds positioned around the screen - check that all LEDs are lit (This can be easily achieved if viewing LED through a digital device i.e camera or camera phone)
	Sensor unit malfunction	Replace sensor unit. (see chapter 10)
	LED Board / cover contaminated	Clean both LED covers and LEDs
The controller unit does not appear to operate correctly	Microswitch failure	Check using Input Test (see chapter 9) to establish operation
	LED board malfunction	Check LED bds positioned around the screen - check that all LEDs are lit (this can be easily achieved if viewing LED through a digital device i.e camera or camera phone)
	Sensor Unit malfunction	Replace the Sensor Unit (see chapter 10)

15 GAME BOARD

WARNING

- When working with the product, be sure to turn the power off. Working with the power on may cause an electric shock or short circuit.
- Be careful not to damage the wires. Damaged wires may cause electric shock, short circuit or present a fire risk.
- Do not expose the game board, etc. without good reason. Failure to observe this can cause electric shock hazard or malfunctioning.
- Do not use this product with connectors other than those that were connected and used with the game board at the time of shipping. Do not carelessly connect wires to connectors that were not used at the time of shipping as this may cause overheating, smoke, or fire damage.
- When returning the game board after making repairs or replacements, make sure that there are no errors in the connection of connectors. Erroneous connections can lead to electrical shock, short circuits or fires.
- When connecting a connector, check the direction carefully. Connectors must be connected in only one direction. If indiscriminate loads are applied in making connections, the connector or its terminal fixtures could be damaged, resulting in electrical shock, short circuits, or fires.

CAUTION

- In this product, setting changes are made during the test mode. The game board need not be operated. Use the game board, etc. as is with the same setting made at the time of shipment so as not to cause electric shock and malfunctioning.
- Static electricity from your body may damage some electronics devices on the IC board. Before handling the IC board, touch a grounded metallic surface so that the static electricity can be discharged.

STOP IMPORTANT

- When a game board is to be replaced, put the old game board with anomaly into a special box for replacing the game board. If a special box is not available or if it has been damaged, arrange to have the Game Board packed in suitable packaging.
- For replacement or repair, pack the game board and send it without disassembling it. Order for servicing may not be accepted if any part of the game board has been removed. If any part is removed, a service fee will be charged even if the warranty period has not yet expired.
- Do not remove the key chip from the game board before sending the board for servicing.

15-1 HOW TO REMOVE GAME BOARD

The game board is inside the Front Door R mounted on the top shelf.

- 1 Turn off the power.
- 2 Unlock Front Door R with Master Key and remove (2) truss screws.

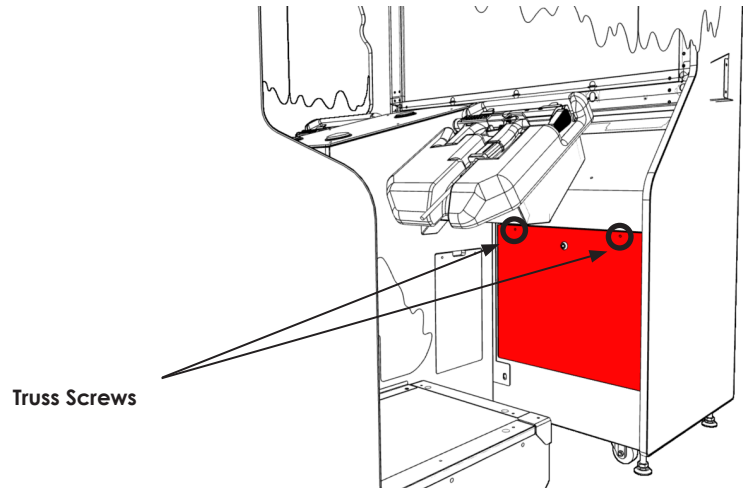

FIG. 16-1a

- 3 Remove Front Door R Panel. The Game Board is located on the top shelf.

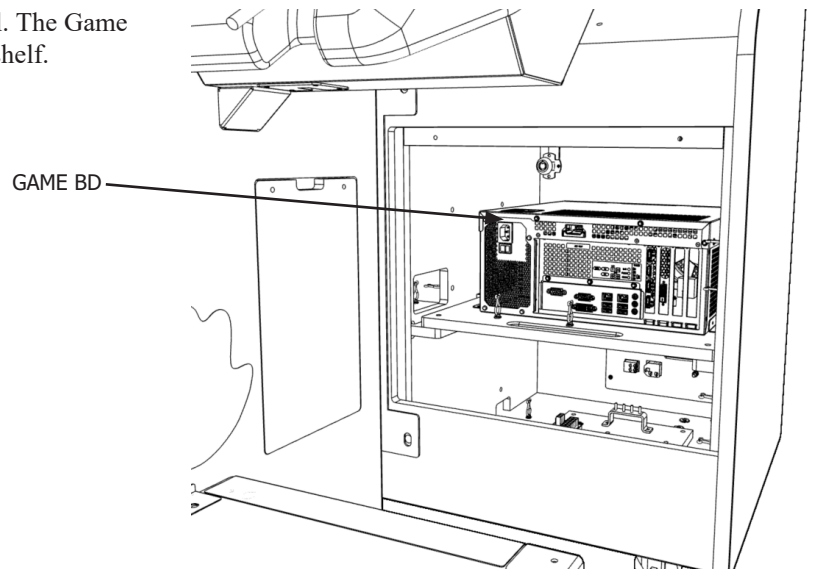

FIG. 16-1b

4 Disconnect Code Clamps

Code Clamp

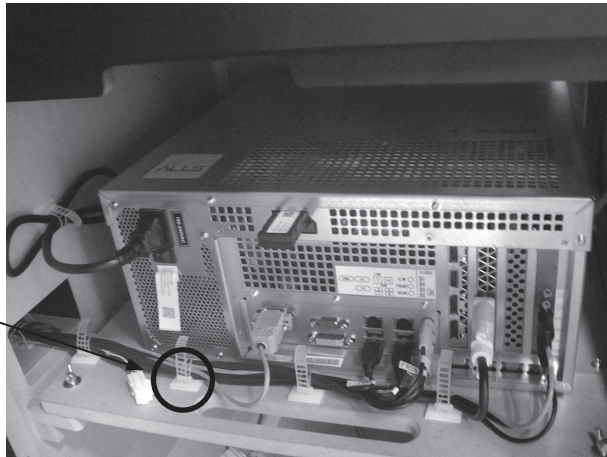

FIG. 16-1c

5 Disconnect all of the connectors connected to the Game Board.

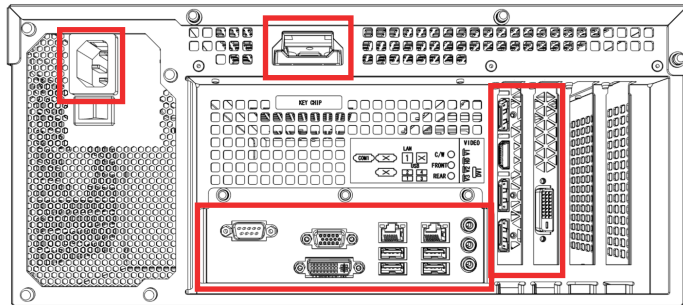
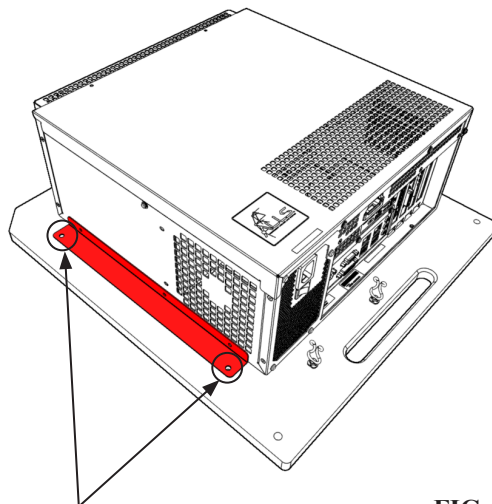

FIG. 16-1d

6 Unscrew the (4) M4 Phillips screws which secure the Game Board in place (2 M4 fixings on each BRKT GAME BOARD).



M4 FIXINGS (2)

FIG. 16-1e

7 Lift and remove the Game Board from the wooden BASE GAME BOARD. The Game Bd is HEAVY, take care not to clash with other components when removing as this could cause component damage.

16 DESIGN RELATED PARTS

For the warning display stickers, refer to Section 1.

HDZ-5501-02UK

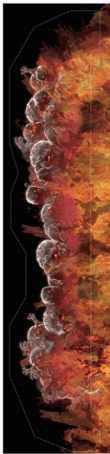

HDZ-5400-01UK

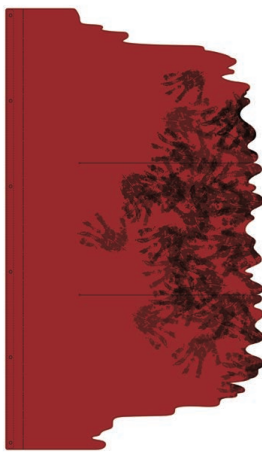

HDZ-5500-01UK



HDZ-5100-01UK



HDZ-5101-01UK



HDZ-5403UK



HDZ-5005-01UK



HDZ-5402-01UK



HDZ-5401-01UK



HDZ-5130-01UK



HDZ-5310-01UK



HDZ-5007-01UK



HDZ-5008-01UK



HDZ-5112-01UK



HDZ-5305-01UK



HDZ-5306-01UK



HDZ-5512-02UK



HDZ-2208UK



17 PARTS LIST

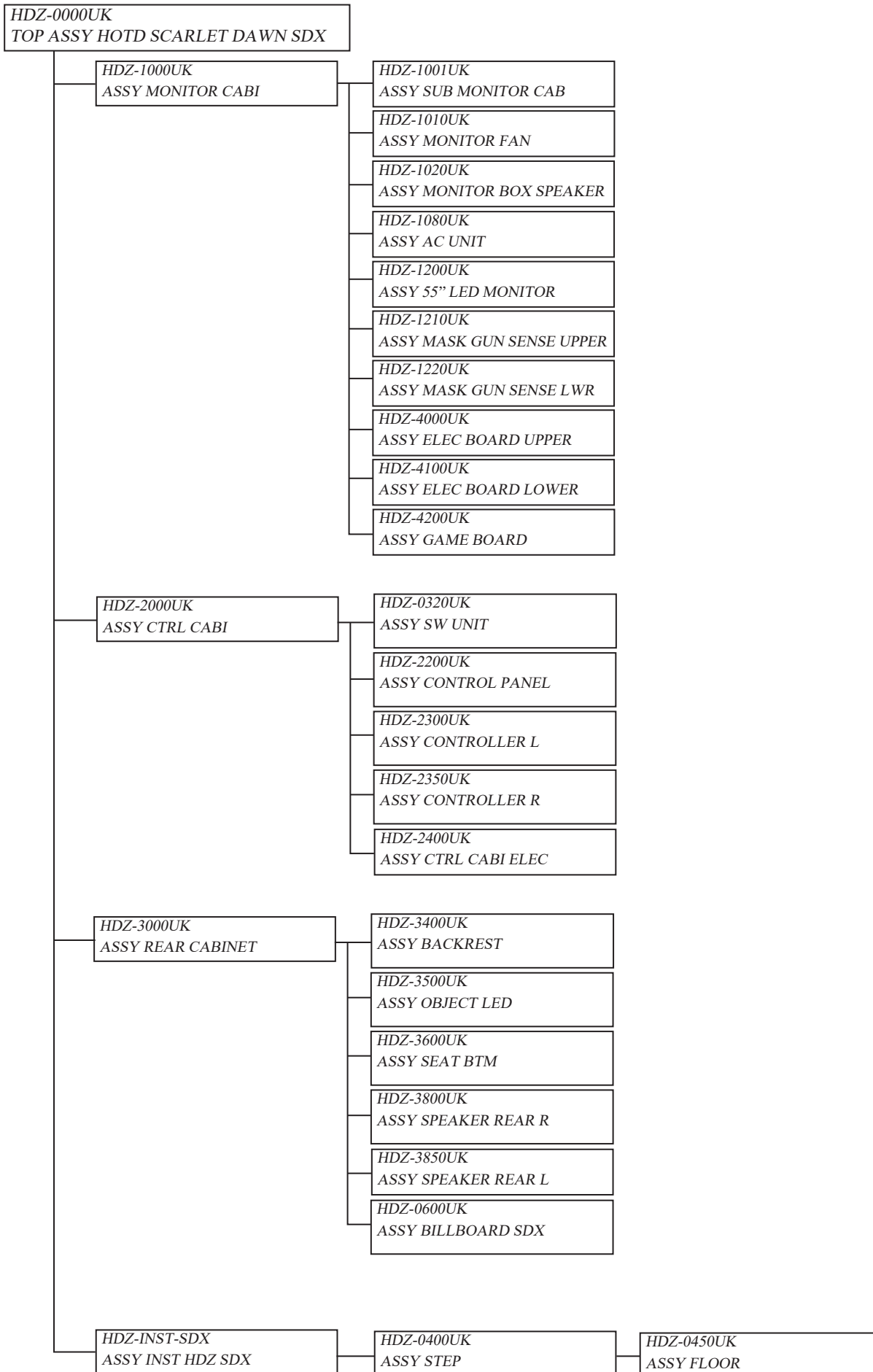

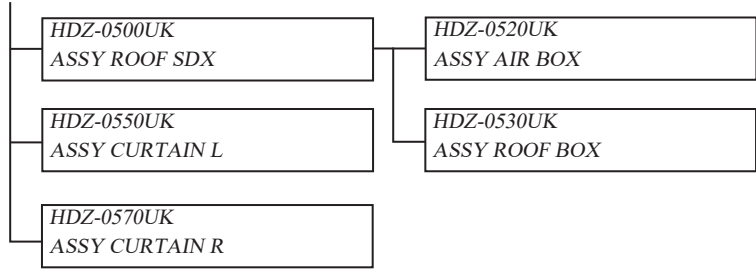

① TOP ASSY HOUSE OF THE DEAD SD SDX (HDZ-0000UK)

(D-1/1)

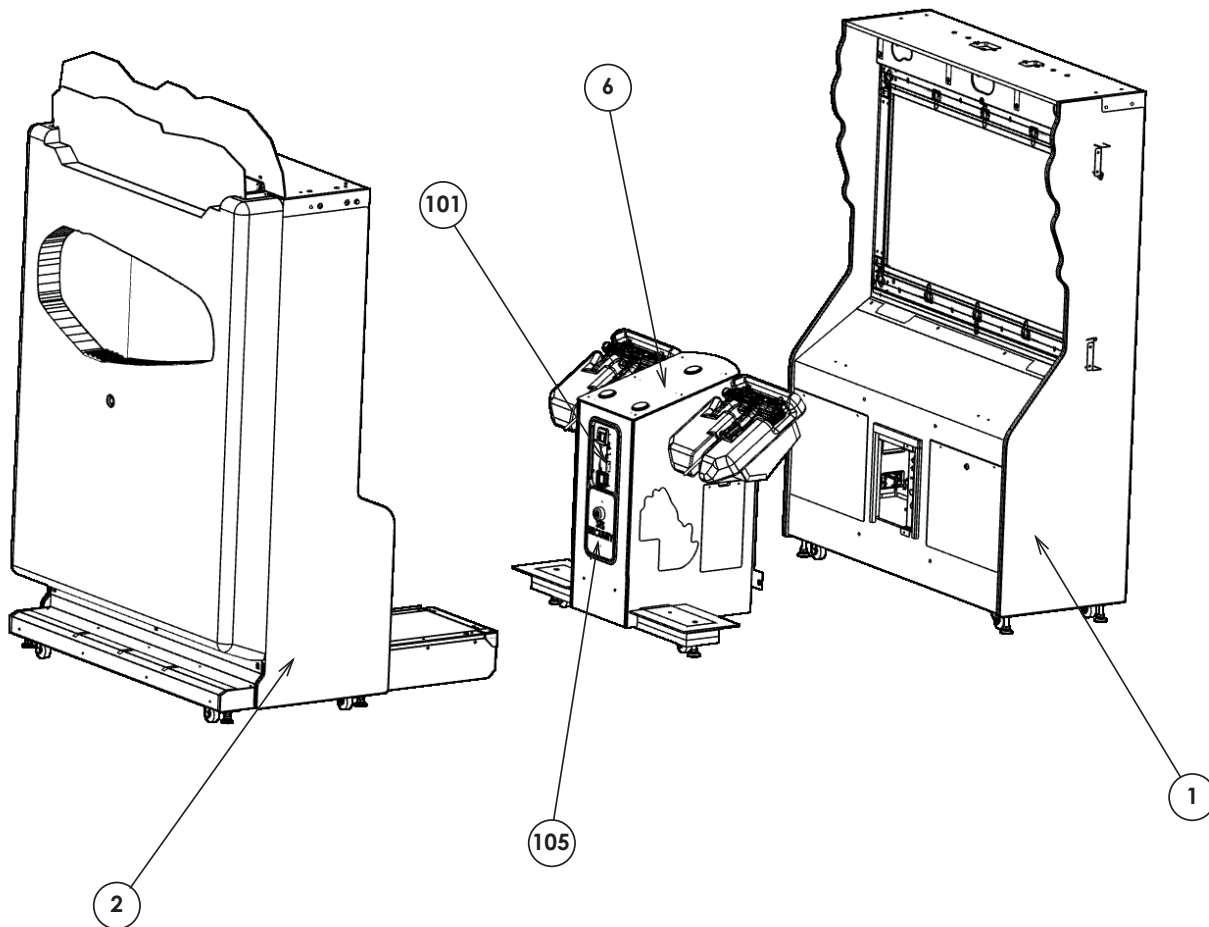

SEQ	PT NUMBER	DESCRIPTION	REFERENCE	QTY
*1	HDZ-1000UK	ASSY MONITOR CABI		1
*2	HDZ-3000UK	ASSY REAR CABINET		1
*6	HDZ-2000UK	ASSY CTRL CABI		1
*7	HDZ-0003UK	BRKT CONTROLLER SUPPORT		2
*20	421-7988-91UK	STICKER SERIAL NUMBER UK		1
*21	440-CS0010UK	STICKER CAUTION GENERIC		3
*22	440-DS0010UK	STICKER DANGER HIGH VOLTAGE		2
*23	440-WS0010UK	STICKER WARNING HI-VOLTAGE		1
*24	440-WS0100UK	STICKER WARNING FORK HERE		4
*25	LB1046	LABEL TESTED FOR ELEC. SAFETY		1
*26	LB1130	LABEL WEEE WHEELIE BIN		1
*101	220-5374-01	DOOR DFMD W/FR&LOCK C120 UNIV		1
*102	220-5575UK	LOCK (J9117) KEY TO LIKE 22MM W CAM		1
*103	OS1247	ALUMINIUM STICKY CLIP ASK-3		3
*105	220-5727-01B	DOOR CASH H.S. STS		1
**1	220-5575-280UK	LOCK(J9117) 28MM W/O CAM		1
*201	029-B00616-0B	M6X16 SKT BH BLK		4
*202	029-B00625-0B	M6X25 SKT BH BLK		4
*203	068-652216	M6 WSHR 22OD FLT BLK		8

Please note: The location of all labels can be found in Chapter 1 of this manual.

② ASSY SW UNIT (HDZ-0320UK)

(D-1/1)

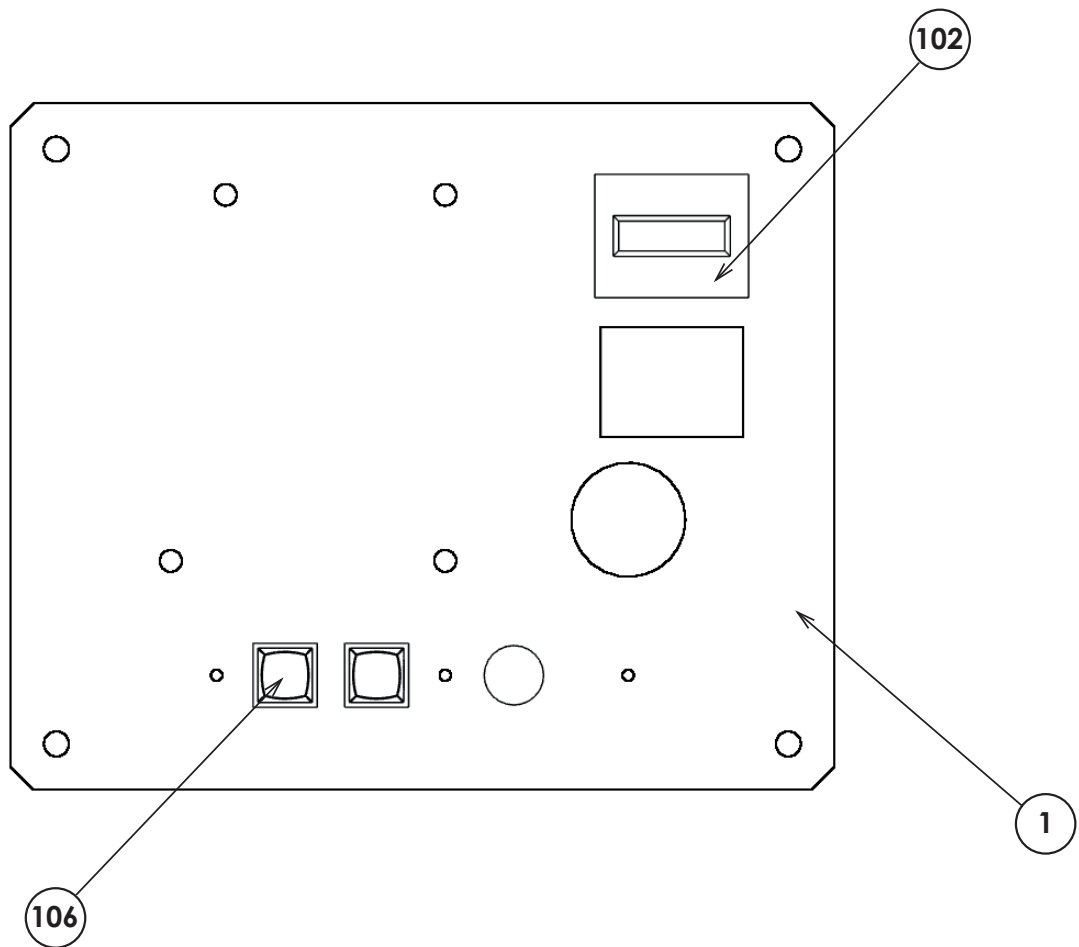

SEQ	PT NUMBER	DESCRIPTION	REFERENCE	QTY
***1	SSR-0321UK	SW BRKT DOUBLE METER		1
***102	220-5643UK	COIN METER SMALL 12V		1
***103	421-12043-01	STICKER SW PANEL CE		1
***104	OS1098	CRIMP BELL END SMALL		2
***105	601-0460	CABLE TIE NYLON 100MM		2
***106	838-14548-01AUK	SW & C VOL BD W/O POT		1
***201	000-P00308-W	M3X8 MSCR PAN W/FS PAS		3
***301	HDZ-60026UK	WH COIN HANDLING		1

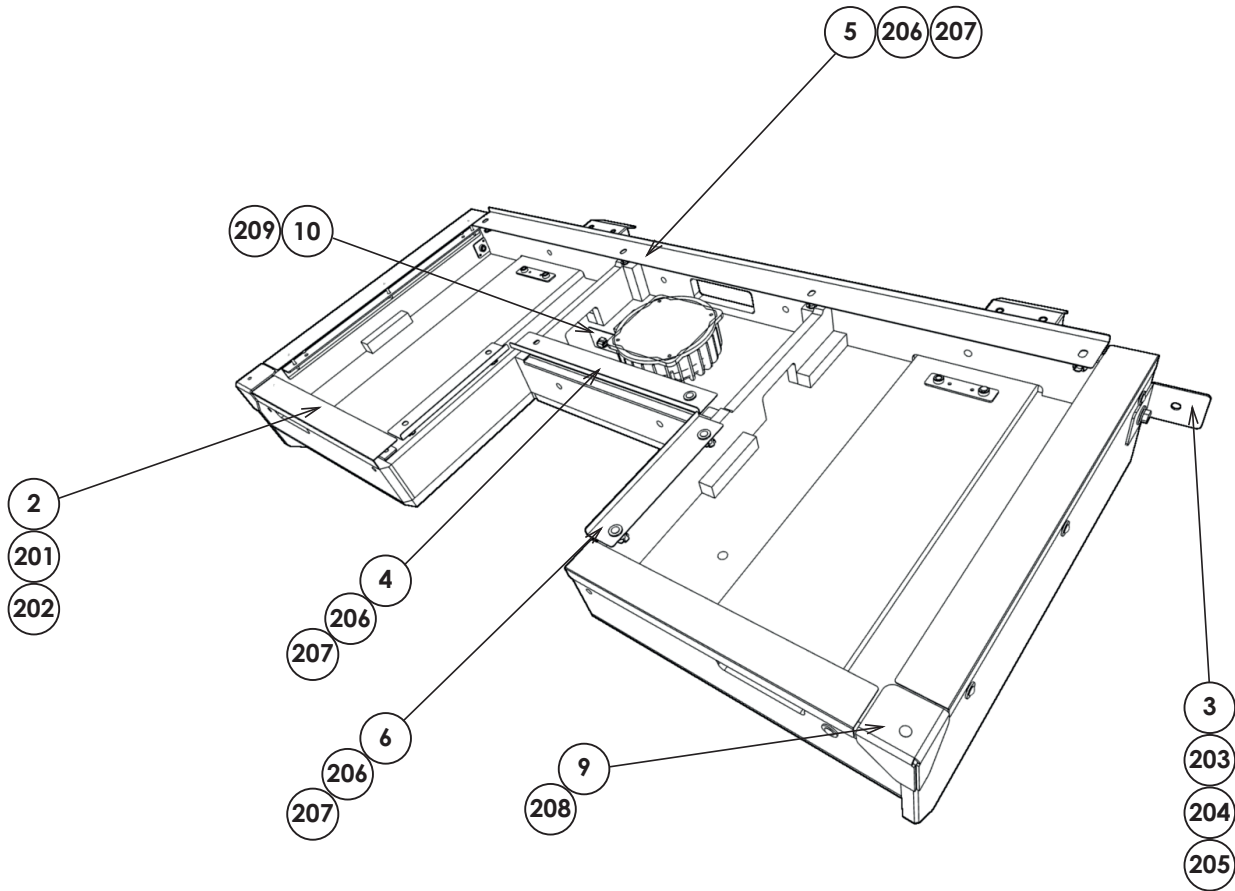

SEQ	PT NUMBER	DESCRIPTION	REFERENCE	QTY
**1	HDZ-0402UK	ASSY CABI STEP		1
***2	117-0001UK	PLATE NUT M8 SINGLE		1
***3	117-0002-060UK	PLATE NUT M8 DUAL 060 CENTRES		2
***201	012-P00412-FB	N8X1/2" S/TAP FLG BLK		2
**2	HDZ-0450UK	ASSY FLOOR		1
**3	HDZ-0406UK	BRKT STEP SEAT JOINT		2
**4	HDZ-0403UK	SASH FLOOR CENTRE		1
**5	HDZ-0405UK	SASH FLOOR REAR		1
**6	HDZ-0404UK	SASH FLOOR CENTRE SIDE		2
**9	HDZ-0408UK	BRKT STEP SEAT CORNER		2
**10	HDZ-0407UK	PLATE CONN PNL BASS SHAKER		1
**201	029-B00425-0B	M4X25 SKT BH BLK		10
**202	068-441616-0B	M4 WSHR 16OD FLT BLK		10
**203	029-B00840-0B	M8X40 SKT BH BLK		2
**204	060-S00800-0B	M8 WSHR SPR BLK		2
**205	068-852216-0B	M8 WSHR 22OD FLT BLK		2
**206	029-B00416	M4X16 SKT BH PAS		10
**207	068-441616	M4 WSHR 16OD FLT PAS		10
**208	029-B00425	M4X25 SKT BH PAS		2
**209	012-P00412-FB	N8x1/2" S/TAP FLG BLK		2
**301	HDZ-60043UK	WH STEP		1

④ ASSY FLOOR (HDZ-0450UK)

(D-1/1)

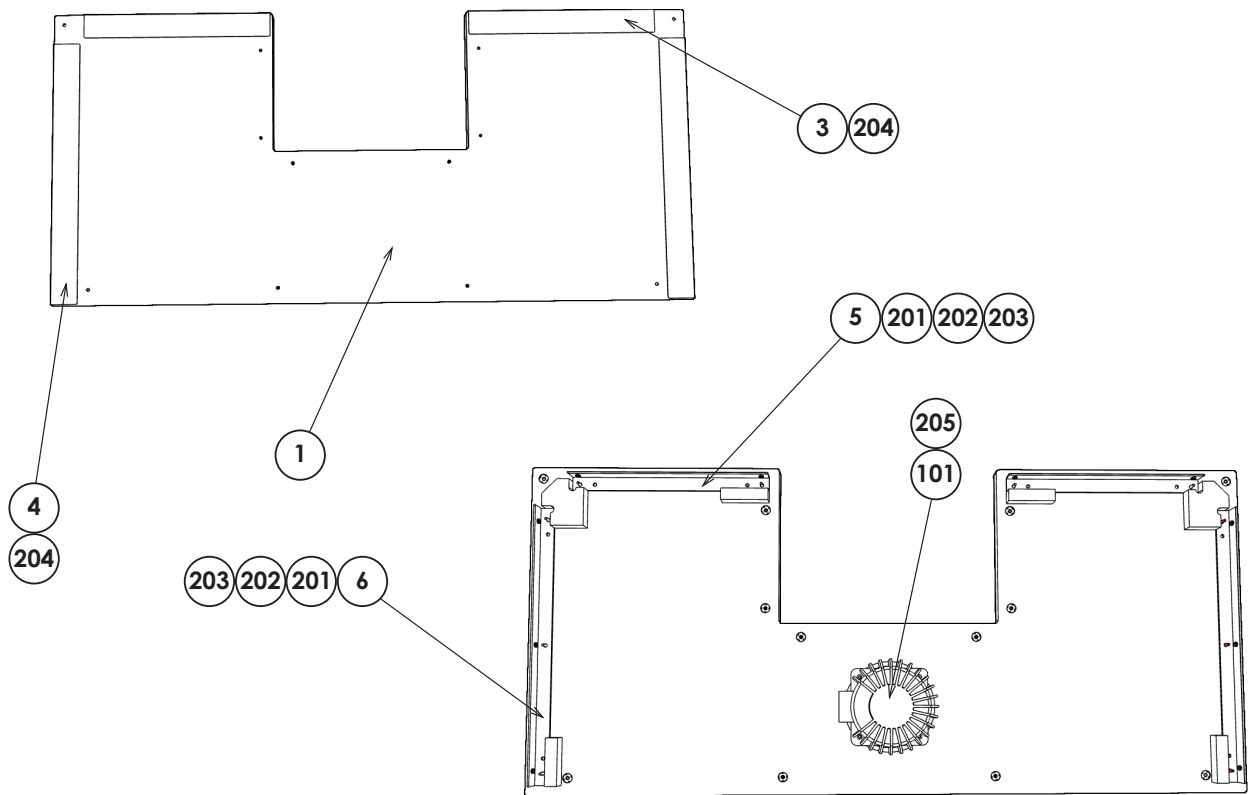

SEQ	PT NUMBER	DESCRIPTION	REFERENCE	QTY
***1	HDZ-0451UK	FLOOR STEP		1
***3	HDZ-0454UK	SASH FLOOR FRONT		2
***4	HDZ-0455UK	SASH FLOOR SIDE		2
***5	HDZ-0452UK	BRKT FLOOR FRONT		2
***6	HDZ-0453UK	BRKT FLOOR SIDE		2
***101	130-5314	BASS SHAKER ACT-50-4		1
***201	029-B00416	M4X16 SKT BH PAS		8
***202	068-441616	M4 WSHR 16OD FLT PAS		18
***203	060-S00400	M4 WSHR SPR PAS		8
***204	050-U00400	M4 NUT NYLOK PAS		10
***205	012-P00416-FB	N8x5/8" S/TAP FLG BLK		4
***301	HDZ-60047UK	WH BASS SHAKER STEP		1

5 ASSY ROOF SDX (HDZ-0500UK)

(D-1/1)

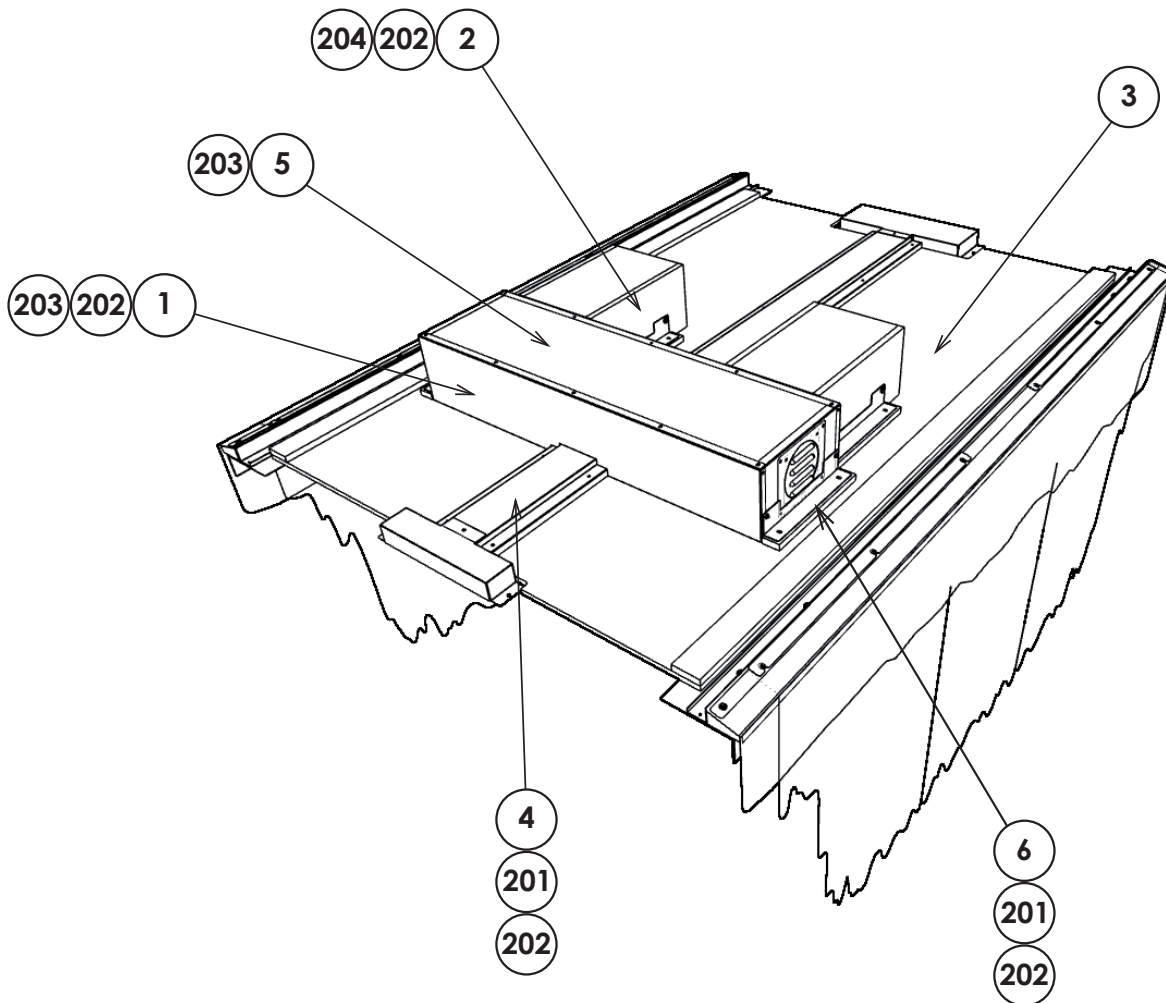

SEQ	PT NUMBER	DESCRIPTION	REFERENCE	QTY
**1	HDZ-0530UK	ASSY ROOF BOX		1
**2	HDZ-0520UK	ASSY AIR BOX		2
**3	HDZ-0501UK	BOARD ROOF		1
**4	HDZ-0505UK	BEAM ROOF		1
**5	HDZ-0532UK	LID BOX ROOF		1
**6	HDZ-0502UK	BRKT BOX SECURE		6
**201	029-B00416-0B	M4X16 SKT BH BLK		28
**202	068-441616-0B	M4 WSHR 16OD FLT BLK		42
**203	029-B00412-0B	M4X12 SKT BH BLK		16
**204	029-B00425-0B	M4X25 SKT BH BLK		8
**301	HDZ-60028UK	WH ROOF AC		1
**302	HDZ-60042UK	WH SIG EXT		1
**303	HDZ-60030UK	WH ROOF SPEAKER		1
**304	HDZ-60035UK	WH ROOF LED OUT		1

⑥ ASSY AIR BOX (HDZ-0520UK)

(D-1/1)

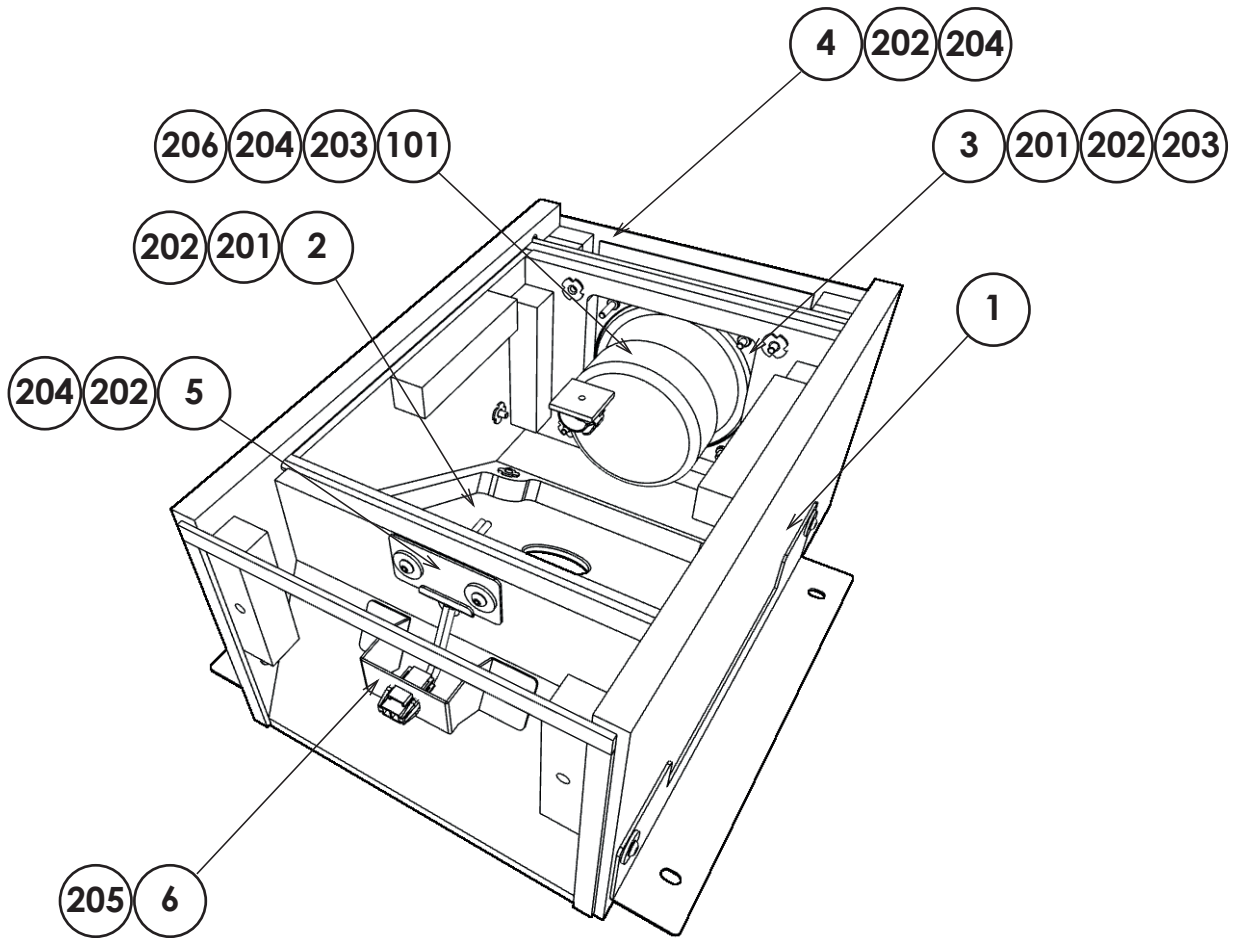

SEQ	PT NUMBER	DESCRIPTION	REFERENCE	QTY
***1	HDZ-0521UK	AIR BOX		1
***2	HDZ-0522-AUK	PLATE AIR BLANK		1
***3	HDZ-0525UK	PLATE MTG SPEAKER AIR		1
***4	HDZ-0526UK	PLATE COVER SPEAKER AIR		1
***5	HDZ-0523UK	PLATE AIR CONN PNL		1
***6	HDZ-0524UK	BRKT AIR CONN PNL		1
***9	HDZ-5403UK	STICKER AIR BOX		1
***101	130-5312	WOOFER 80HM 40W 12CM		1
***201	029-B00425-0B	M4X25 SKT BH BLK		8
***202	068-441616-0B	M4 WSHR 16OD FLT BLK		16
***203	060-S00400-0B	M4 WSHR SPR BLK		8
***204	029-B00416-0B	M4X16 SKT BH BLK		12
***205	012-P00412-FB	N8x1/2" S/TAP FLG BLK		2
***206	060-F00400	M4 WSHR FORM A FLT PAS		4
***301	HDZ-60048UK	WH AIR GIMMICK WOOFER		1

⑦ ASSY ROOF BOX (HDZ-0530UK)

(D-1/1)

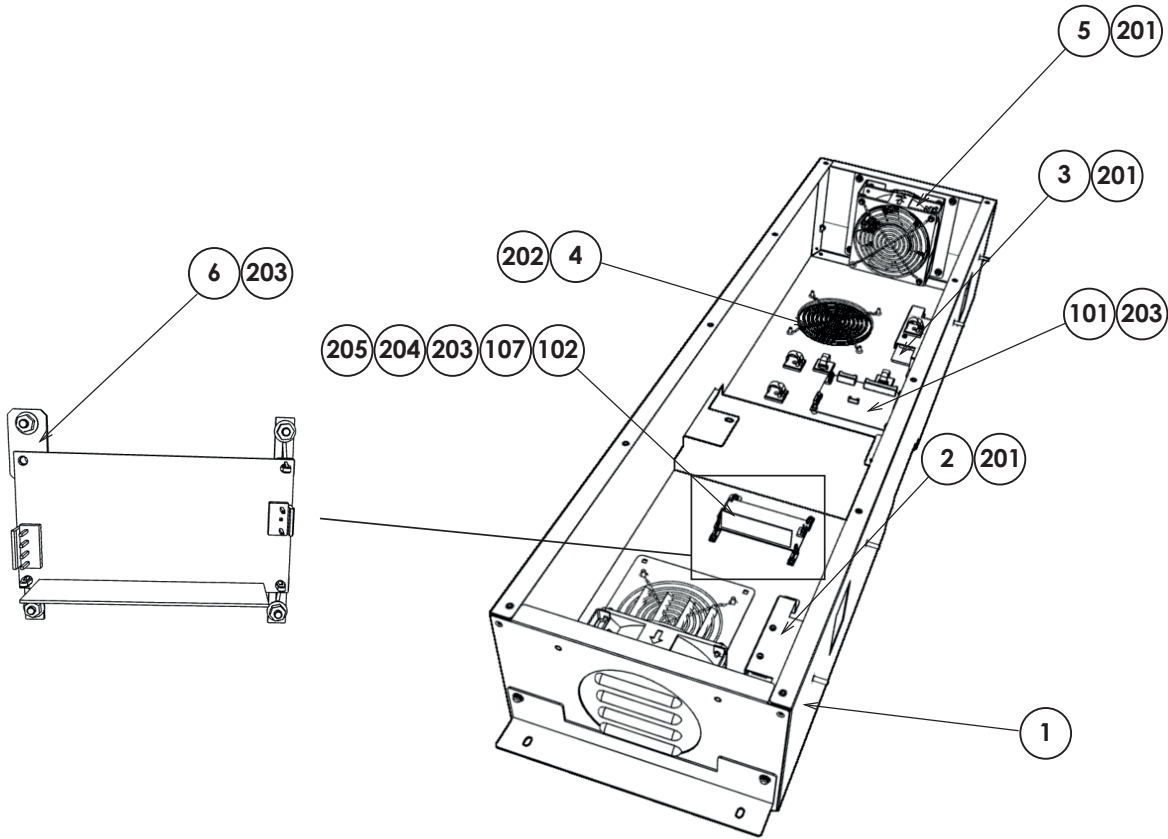

SEQ	PT NUMBER	DESCRIPTION	REFERENCE	QTY
***1	HDZ-0531UK	BOX ROOF		1
***2	HDZ-0533UK	BRKT LIGHT ROOF		2
***3	HDZ-0534UK	COVER LIGHT ROOF		2
***4	FN1012	FAN GUARD METAL 120MM (FG-12)		2
***5	SND-1340UK	ASSY FAN		2
***6	DSD-4002UK	PLATE PSU POST		1
***101	837-15070-04	IC BD LED DRV32CH RS232		1
***102	400-150-012-03	PSU 12V DC 150W MW EPP-150-12		1
***103	838-19187	RGB SPOTLIGHT LED BD 5V		4
***107	OS1011	PCB FEET RICHCO LCBS-L-5-01		3
***201	050-F00400	M4 NUT FLG SER PAS		17
***202	050-U00400	M4 NUT NYLOK PAS		8
***203	050-U00300	M3 NUT NYLOK PAS		8
***204	020-B00308-0B	M3X8 SKT BH BLK		9
***205	060-F00300	M3 WSHR FORM A FLT PAS		1
***301	HDZ-60032UK	WH ROOF POWER		1
***302	HDZ-60033UK	WH ROOF LED		1
***303	HDZ-60046UK	WH AIR GIMMICK		1
***304	HDZ-60034UK	WH SPOT LIGHT		2
***305	HDZ-60029UK	WH ROOF SIG		1
***306	HDZ-60049UK	WH WOOFER		2

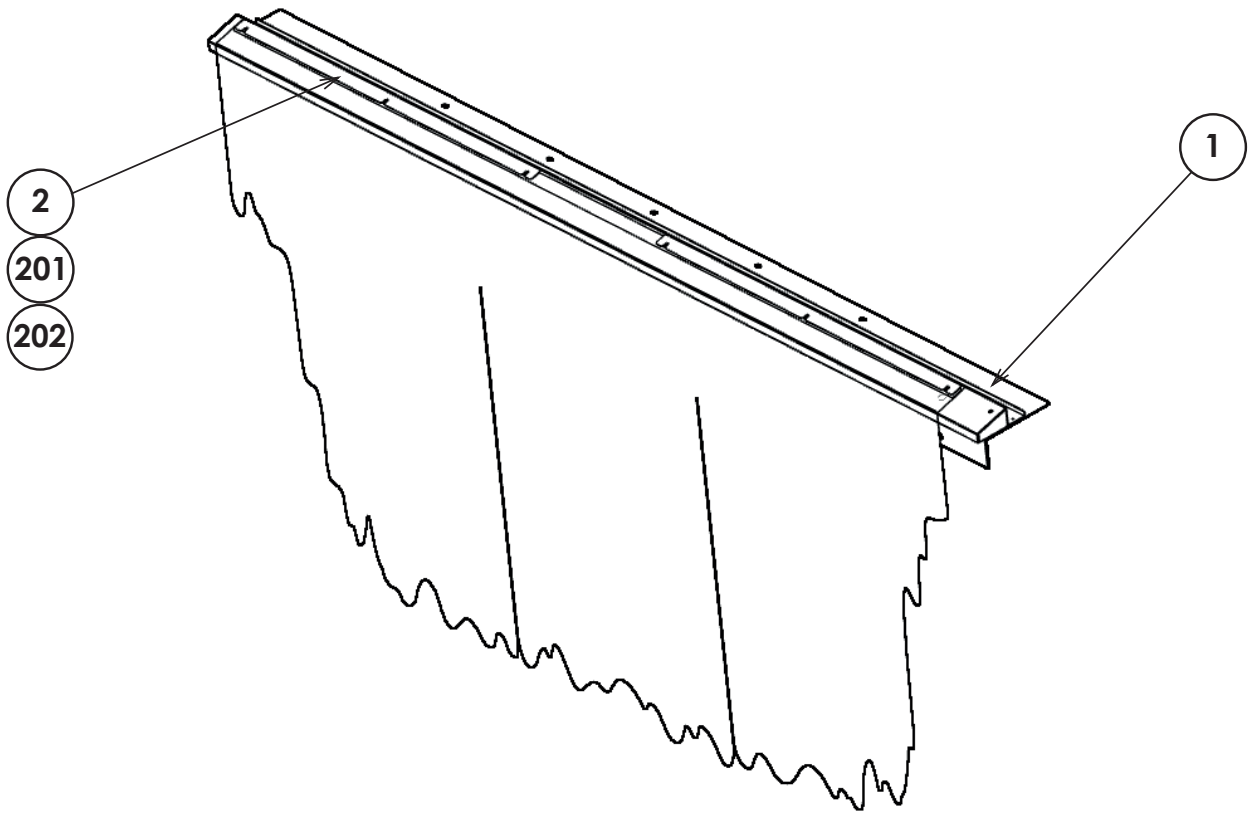

SEQ	PT NUMBER	DESCRIPTION	REFERENCE	QTY
***1	HDZ-0551UK	BRKT JOINT ROOF LEFT		1
***2	HDZ-0552UK	SASH CURTAIN		2
***201	029-B00416	M4X16 SKT BH PAS		7
***202	068-441616	M4 WSHR 16OD FLT PAS		7

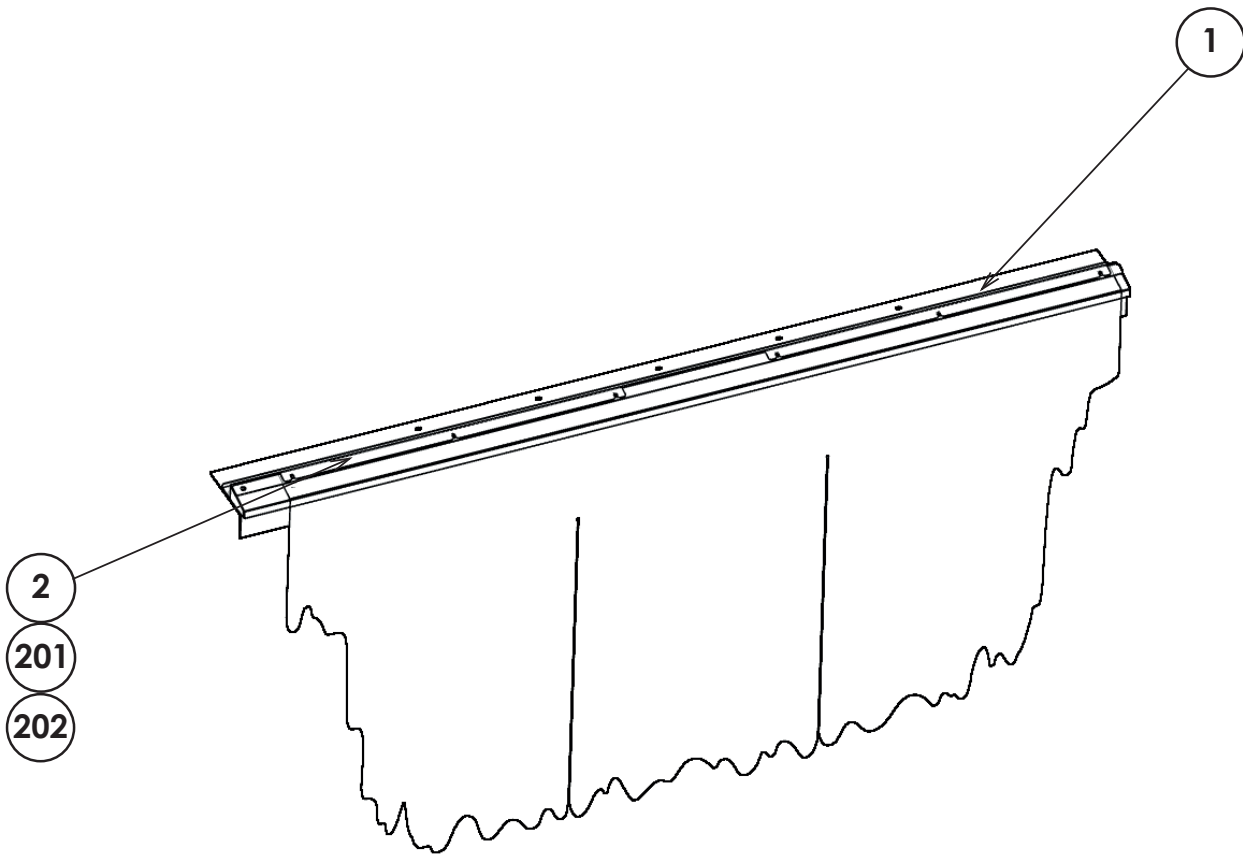

SEQ	PT NUMBER	DESCRIPTION	REFERENCE	QTY
***1	HDZ-0551UK	BRKT JOINT ROOF LEFT		1
***2	HDZ-0552UK	SASH CURTAIN		2
***201	029-B00416	M4X16 SKT BH PAS		7
***202	068-441616	M4 WSHR 16OD FLT PAS		7

⑩ ASSY BILLBOARD SDX (HDZ-0600UK)

(D-1/1)

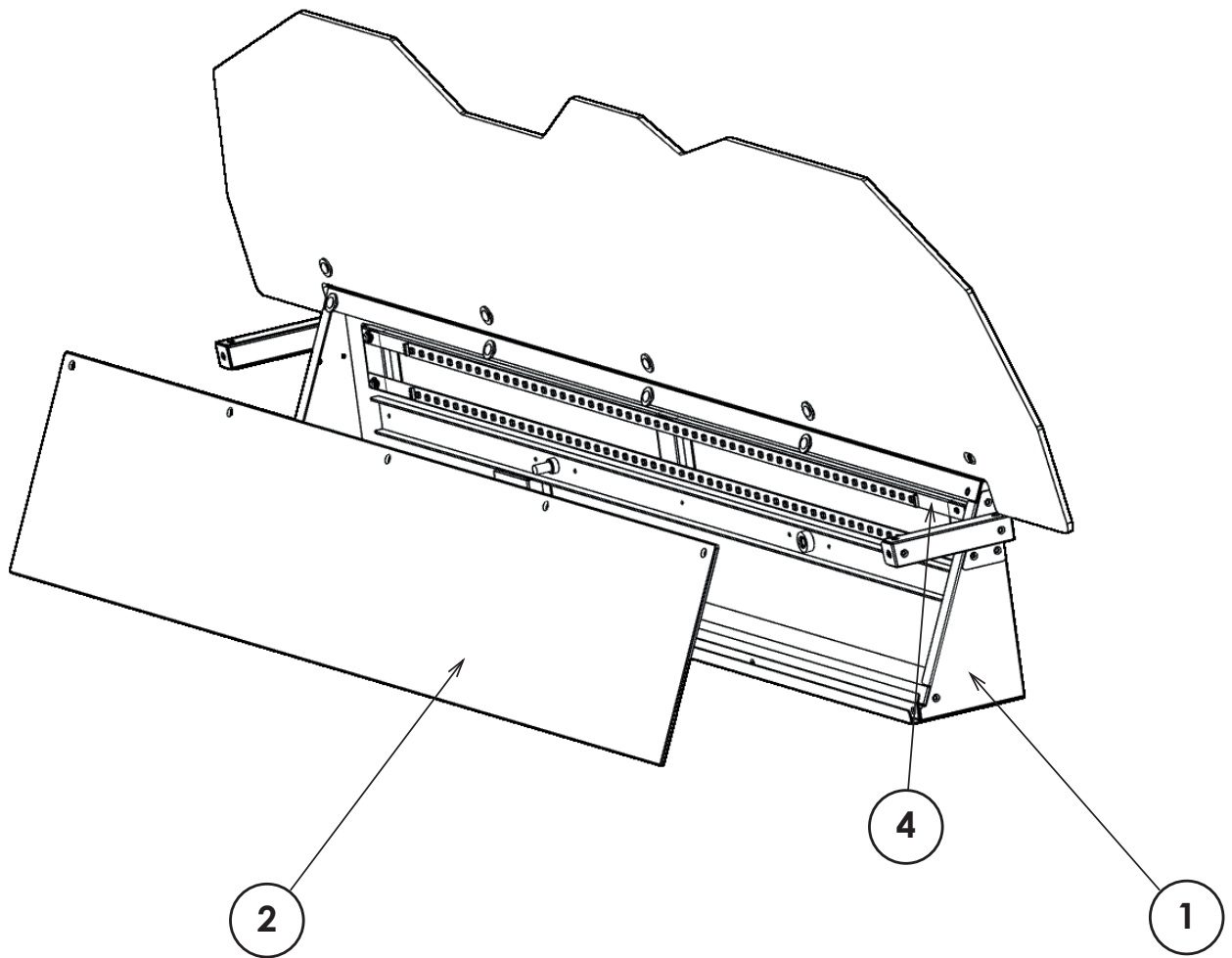

SEQ	PT NUMBER	DESCRIPTION	REFERENCE	QTY
**1	HDZ-0601UK	BOX BILLBOARD		1
**2	HDZ-0602UK	COVER LIGHT BILLBOARD		1
**4	HDZ-0604UK	BRKT BASE LED MTG		2
**301	HDZ-60037UK	WH BILLBOARD		1
**302	HDZ-6001UK	ASSY LED BILLBOARD		2
***101	390-2112-100UK	LED RIGID WHITE 1000MM		1
***301	DB-60030UK	WH LED WHT		1

⑪ ASSY MONITOR CAB (HDZ-1000UK)

(D-1/2)

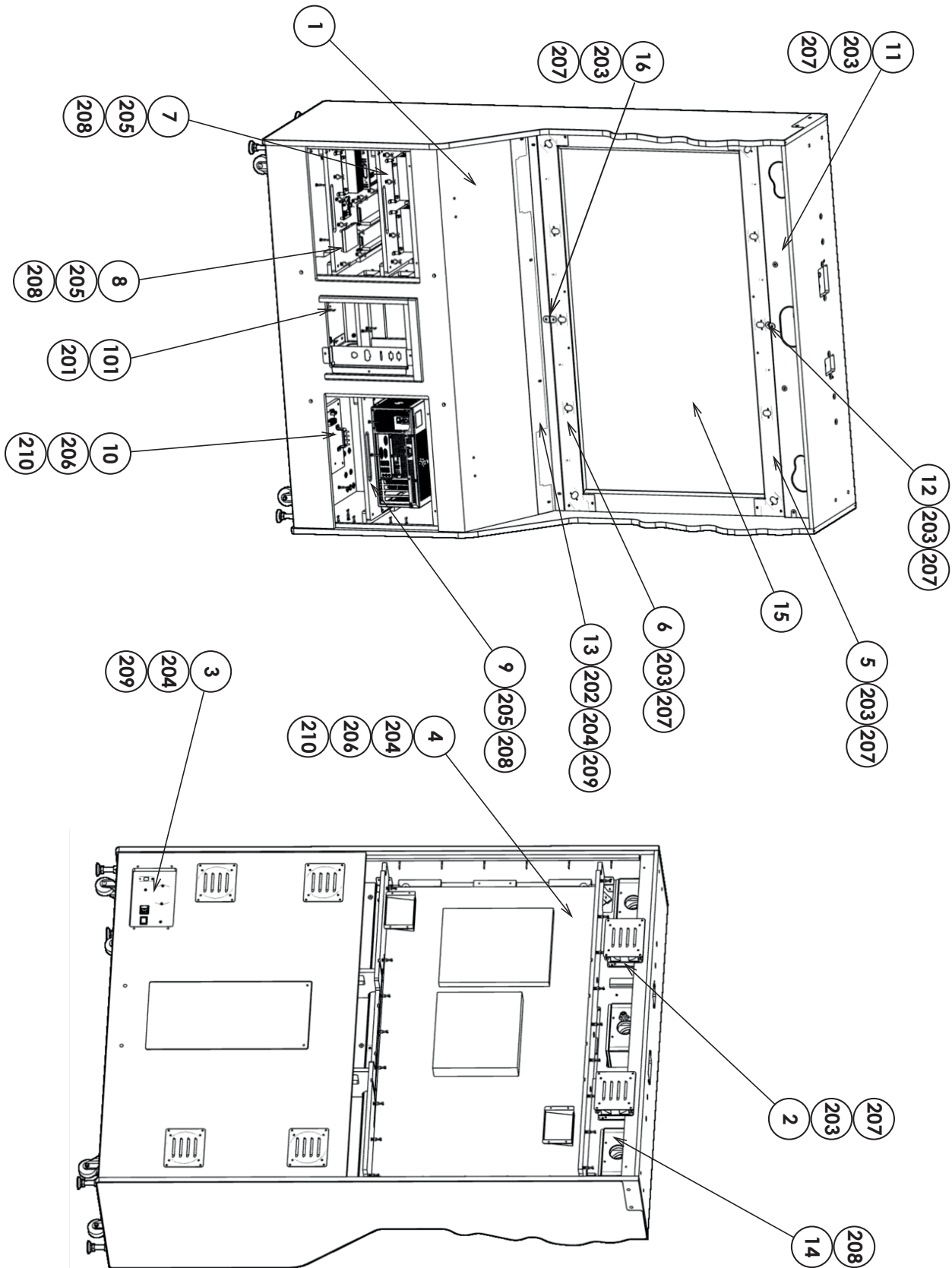

11 ASSY MONITOR CABI (HDZ-1000UK)

(D-2/2)

ITEM NO	PART NO	DESCRIPTION	REFERENCE	QTY
**1	HDZ-1001UK	ASSY SUB MONITOR CABI		1
**2	HDZ-1010UK	ASSY MONITOR FAN		2
**3	HDZ-1080UK	ASSY AC UNIT		1
**4	HDZ-1200UK	ASSY 55" LED MONITOR		1
**5	HDZ-1210UK	ASSY MASK GUN SENSE UPPER		1
**6	HDZ01220UK	ASSY MASK GUN SENSE LOWER		1
**7	HDZ-4000UK	ASSY ELEC BD UPPER		1
**8	HDZ-4100UK	ASSY ELEC BD LOWER		1
**9	HDZ-4200UK	ASSY GAMEBOARD		1
**10	HDZ-4300UK	ASSY XFMR BD		1
**11	HDZ-1014UK	SPEAKER MASK		1
**12	HDZ-1016UK	MASK STRAP UPPER		1
**13	HDZ-1017UK	SASH MONITOR SENSOR LOWER		1
**14	HDZ-1020UK	ASSY MONITOR BOX SPEAKER		3
**15	HDZ-1209UK	GLASS LED 55" SCREEN PROTECT		1
**16	LMA-7003UK	MASK STRAP		1
**18	HDZ-5007-01UK	MON CABI LH CHEEK STICKER		
**20	HDZ-5008-01UK	MON CABI RH CHEEK STICKER		
**21	HDZ-5005-01UK	SPEAKER MASK STICKER		
**101	838-14551-02UK	AC DISTRIBUTION BD		
**102	280-A012640-WX	ROUTER TWIST D12 SO6.4 WOOD XL		
**201	012-P00325	N4X1" S/TAP PAN PAS		
**202	029-B00412-0B	M4X12 SKT BH BLK		
**203	029-B00416-0B	M4X16 SKT BH BLK		
**204	029-B00425-0B	M4X25 SKT BH BLK		
**205	029-B00430	M4X30 SKT BH PAS		
**206	029-B00625	M6X25 SKT BH PAS		
**207	060-F00400-0B	M4 WSHR FORM A FLT BLK		
**208	068-441616	M4 WSHR 16OD FLT PAS		
**209	068-441616-0B	M4 WSHR 16OD FLT BLK		
**210	068-652216	M6 WSHR 22OD FLT PAS		
*301	HDZ-60003UK	WH AC OUT TH		
*302	HDZ-60004UK	WH AC DIST ELEC		
*303	HDZ-60014UK	WH AC IN ELEC TH		
*304	HDZ-60019UK	WH LED G SENSE 3		
*305	HDZ-60020UK	EH DC OUT		
*306	HDZ-60021UK	WH CONTROLLER EXT		
*307	HDZ-60022UK	WH SPEAKER OUT MONITOR		

12 ASSY SUB MONITOR CABI (HDZ-1001UK)

(D-1/2)

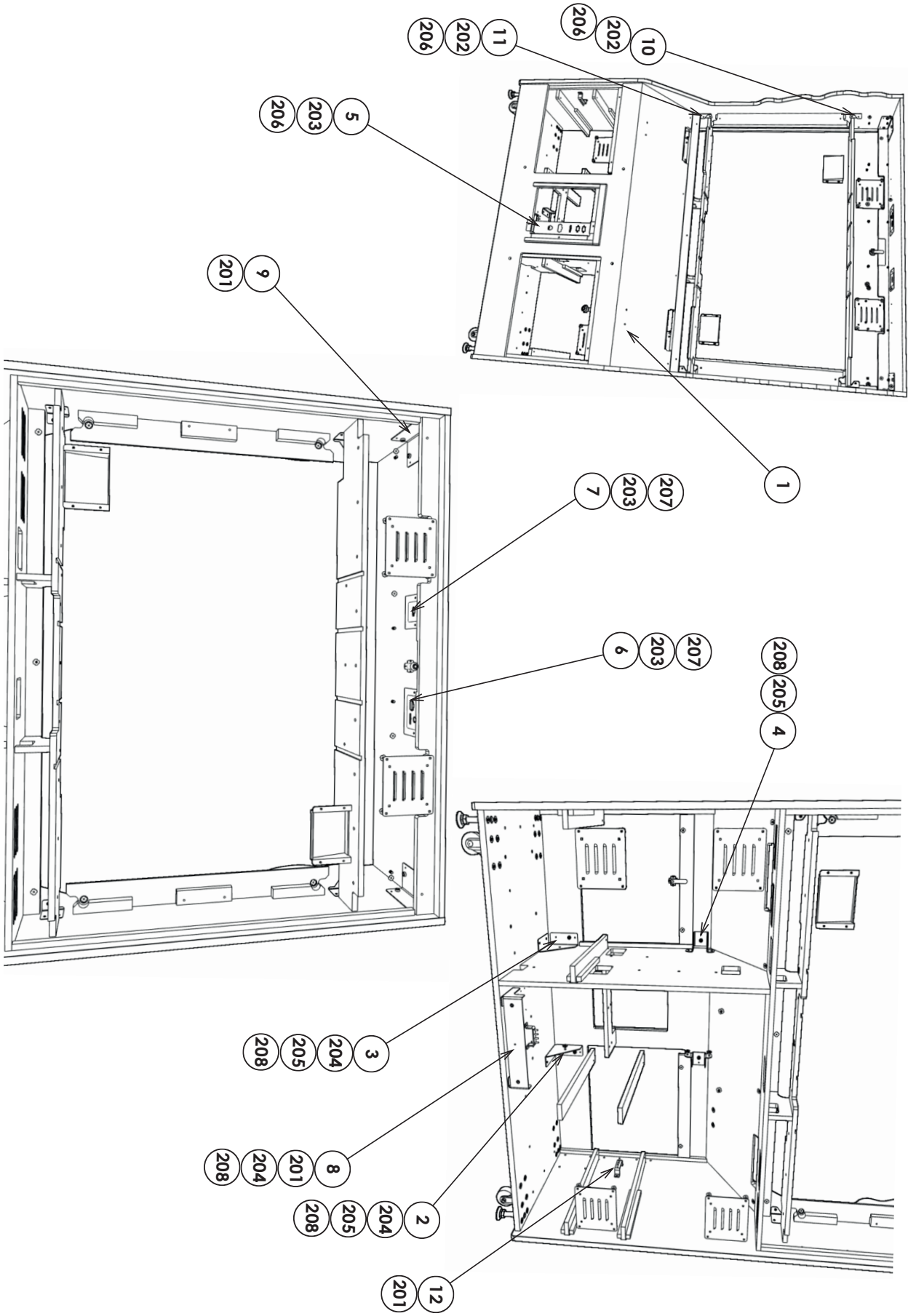

⑫ ASSY SUB MONITOR CABI (HDZ-1001UK)

(D-2/2)

ITEM NO	PART NO	DESCRIPTION	REFERENCE	QTY
***1	HDZ-1002UK	ASSY MONITOR CABINET		1
****2	HDZ-1002-BUK	DOOR UPPER BACK		1
****3	HDZ-1002-CUK	DOOR LOWER BACK		1
****4	HDZ-1002-DUK	DOOR ELEC ACCESS		1
****5	HDZ-1002-EUK	DOOR GAMEBOARD ACCESS		1
***2	HDZ-1003UK	JOINT BRKT CTRL LOWER LH		1
***3	HDZ-1004UK	JOINT BRKT CTRL LOWER RH		1
***4	HDZ-1005UK	JOINT BRKT CTRL UPPER		2
***5	HDZ-1006UK	CONN PNL MONITOR		1
***6	HDZ-1007UK	CONN PNL ROOF LH		1
***7	HDZ-1008UK	CONN PNL ROOF RH		1
***8	HDZ-1009UK	JOINT BRKT SHIPPING		1
***9	HDZ-1011UK	JOINT BRKT ROOF		2
***10	LMA-7005UK	BRKT CORNER SECURE SENSOR BAR		2
***11	LMA-7006UK	BRKT CORNER SECURE ADJ SENSOR		2
		BAR		
***12	CFB-4003-01UK	EARTH TERMINAL PLATE		2
***101	FN1012	FAN GUARD METAL 120MM (FG-12)		4
***201	012-P03512-F	N6X1/2" S/TAP FLG PAS		13
***202	029-B00412	M4X12 SKT BH PAS		24
***203	029-B00416	M4X16 SKT BH PAS		7
***204	029-B00612	M6X12 SKT BH PAS		8
***205	029-B00625	M6X25 SKT BH PAS		6
***206	060-F00400	M4 WSHR FORM A FLT PAS		27
***207	068-441616	M4 WSHR 16OD FLT PAS		4
***208	068-652216	M6 WSHR 22OD FLT PAS		14

13 ASSY MONITOR FAN (HDZ-1010UK)

(D-1/1)

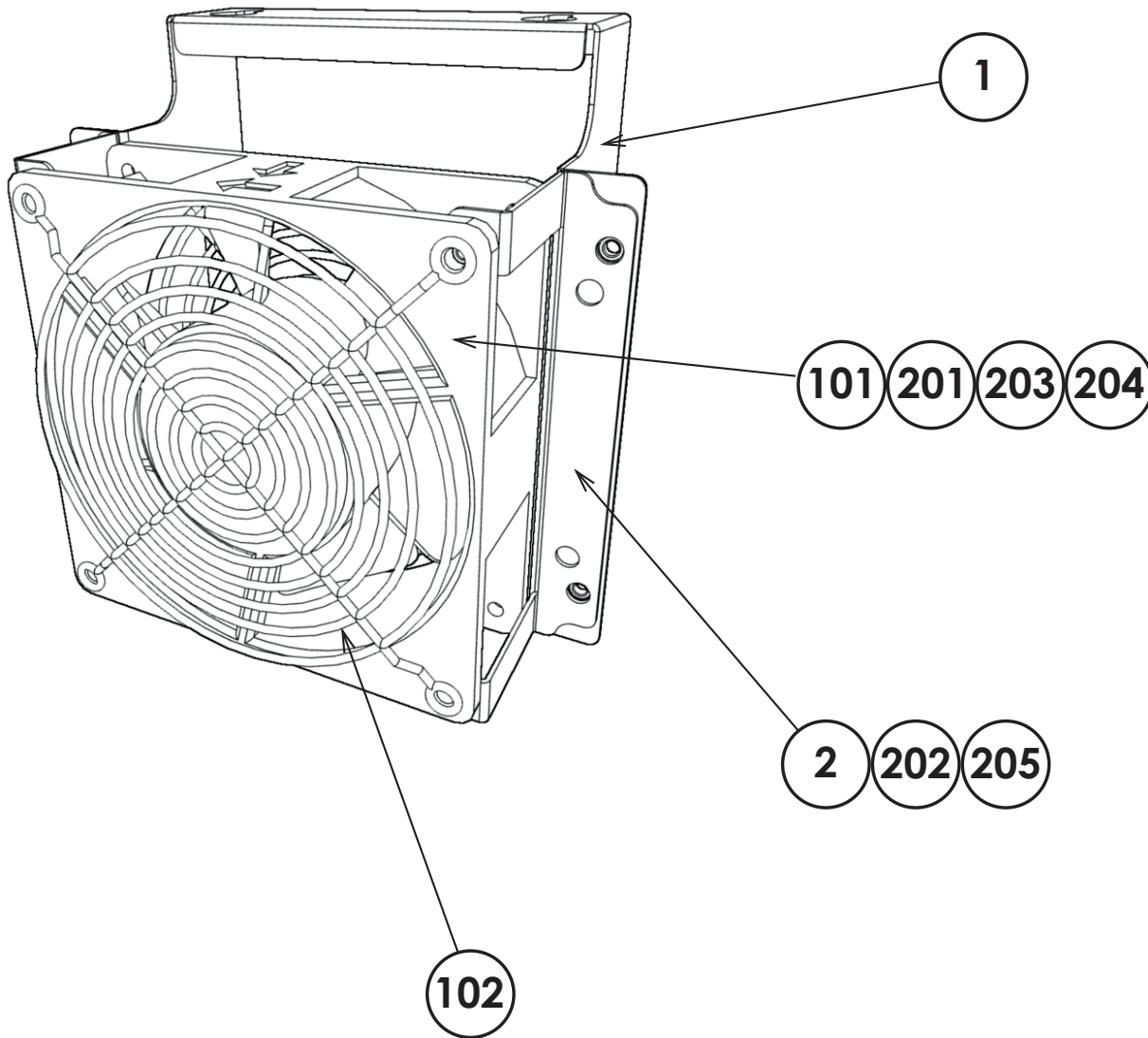

ITEM NO	PART NO	DESCRIPTION	REFERENCE	QTY
***1	HDZ-1012UK	MONITOR FAN BRKT		1
***2	HDZ-1013UK	BRKT FAN LOCATING		2
***101	260-0012-01UK	FAN DC 12V AXIAL		1
***102	FN1012	FAN GUARD METAL 120MM (FG-12)		2
***103	OS1195	RIVET SNAP SR-4080B		4
***201	020-B00316-0B	M3X16 SKT BH BLK		4
***202	029-B00412	M4X12 SKT BH PAS		4
***203	060-S00300-0B	M3 WSHR SPR BLK		4
***204	060-F00300-0B	M3 WSHR FORM A FLT BLK		4
***205	060-F00400	M4 WSHR FORM A FLT PAS		4
***301	DB-60030UK	WH LED WHT		1

⑭ ASSY MONITOR BOX SPEAKER (HDZ-1020UK)

(D-1/1)

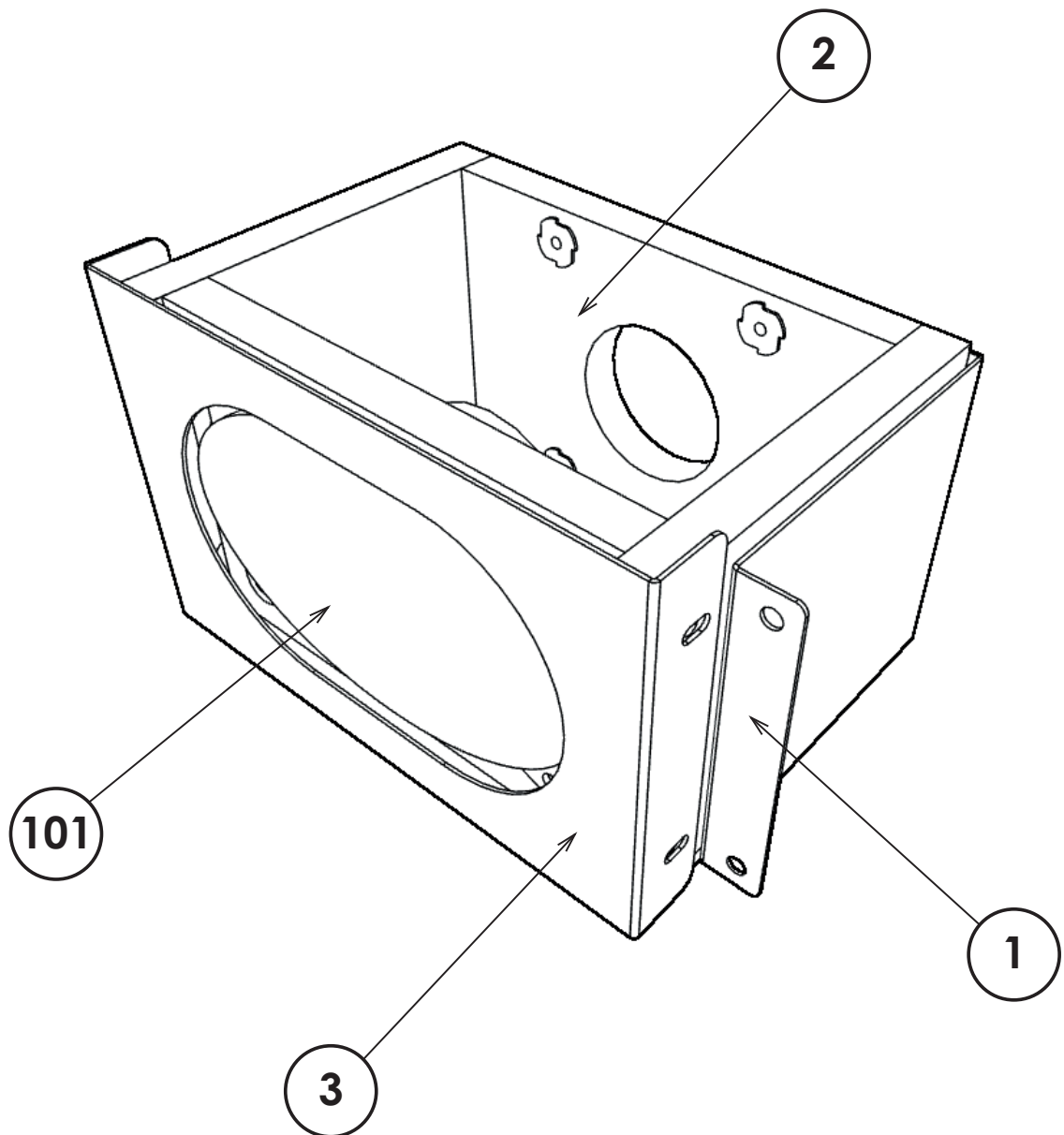

ITEM NO	PART NO	DESCRIPTION	REFERENCE	QTY
**1	HDZ-1021UK	BRKT MONITOR SPEAKER		1
**2	HDZ-1022UK	BOX SPEAKER		1
**3	HDZ-1023UK	PLATE SPEAKER COVER		1
**101	130-04030-E	SPKR ELIP 4OHM 30W VIS DX4x6P		1
**201	012-P00412-FB	N8x1/2" S/TAP FLG BLK		4
**202	029-B00416-0B	M4X16 SKT BH BLK		4
**203	029-B00425-0B	M4X25 SKT BH BLK		4
**204	060-S00400-0B	M4 WSHR SPR BLK		8
**205	068-441616	M4 WSHR 16OD FLT BLK		8
**301	HDZ-60050UK	WH SPEAKER		1

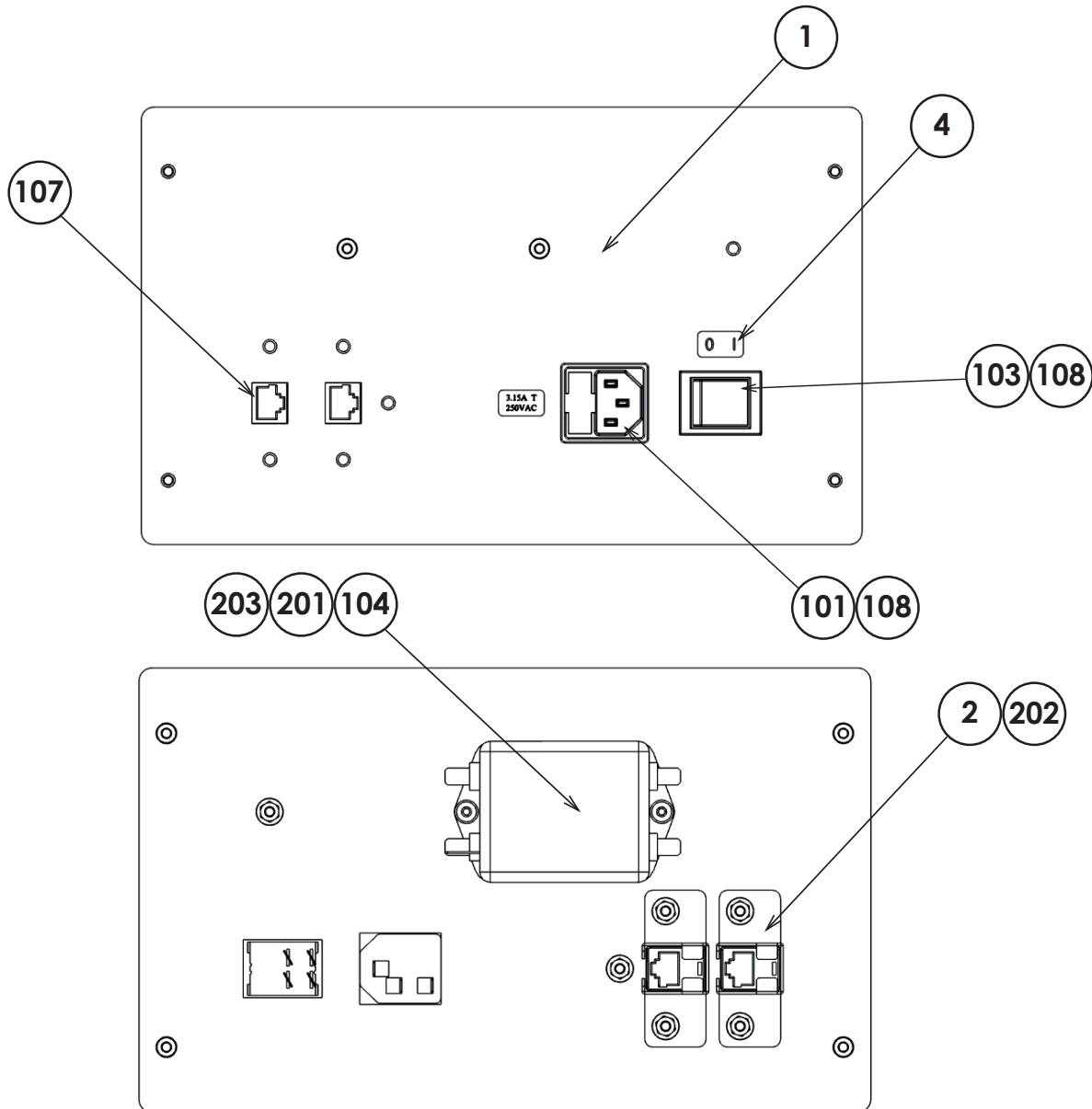

ITEM NO	PART NO	DESCRIPTION	REFERENCE	QTY
***1	DA-1081UK	PLATE AC		1
***2	TFF-0402UK	CONN COVER		1
***3	LB1096	STICKER PROTECTIVE EARTH		1
***4	LB1131	LABEL ON / OFF		1
***5	ST-0403UK	PLATE AC CAP		1
***101	EP1302	EUROSOCKET FUSED 10A 250VAC		1
***102	514-5078-3150	FUSE 3.15 X 20 CERAMIC SB 3150mA		2
***103	SW1109	SWITCH ROCKER 250V AC		1
***104	EP1419	FILTER SCHAFFNER 2030-16-06		1
***107	EP1391	COUPLER INLINE LAN RJ45		1
***108	310-5029-D508	HEAT SHRINK SLEEVING 50.8DIA		8cm
***109	LB1126-3150-250	FUSE LABEL 3.15A 250V		1
***201	029-B00408	M4X8 SKT BH PAS		2
***202	050-F00400	M4 NUT FLG SER PAS		6
***203	060-S00400	M4 WSHR SPR PAS		2
***301	DA-60101UK	WH AC IN		1

①⑥ ASSY 55 LED DISPLAY (HDZ-1200UK)

(D-1/1)

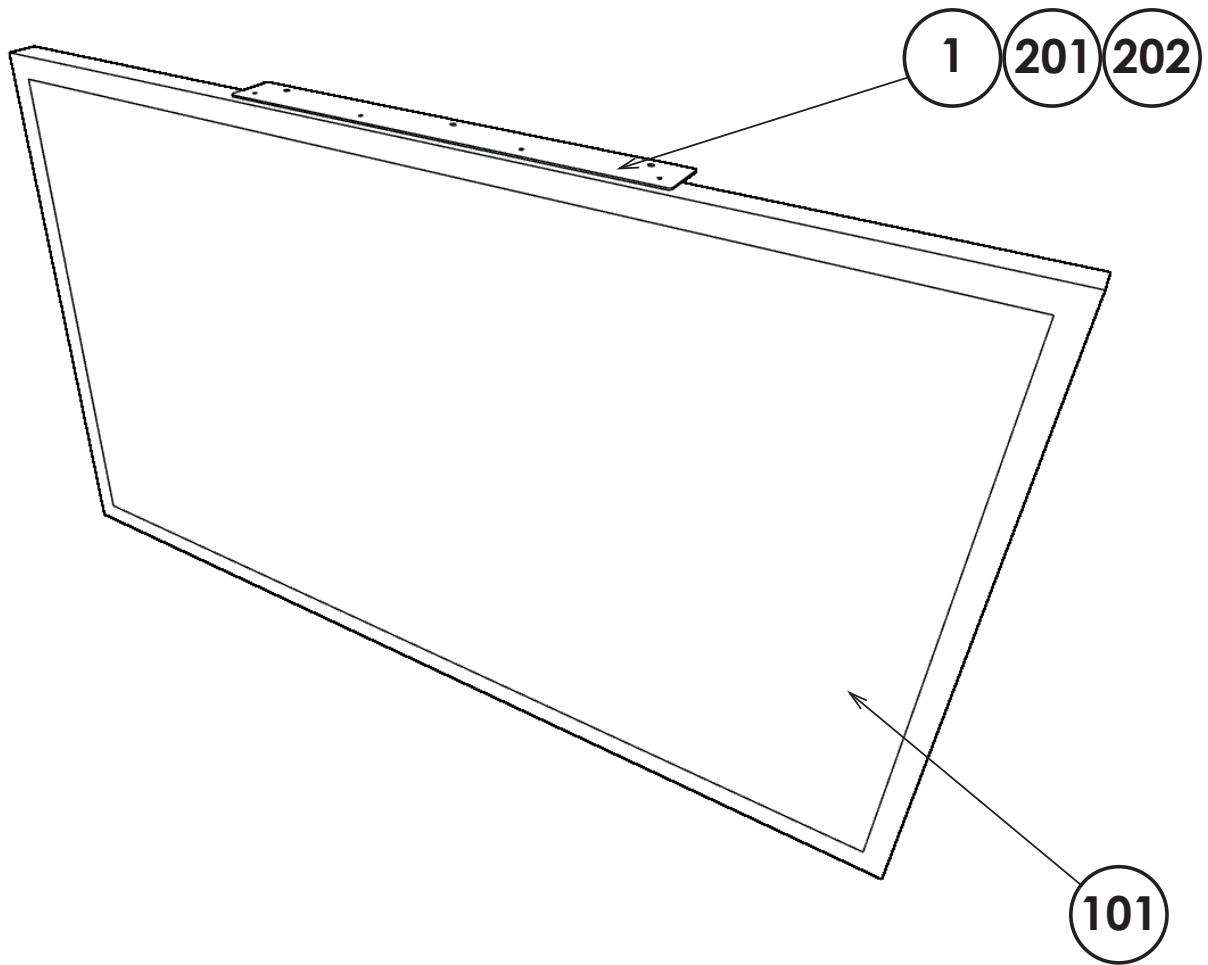

ITEM NO	PART NO	DESCRIPTION	REFERENCE	QTY
***1	HDZ-1201UKUK	PLATE MONITOR LOCATING		2
***101		LED 55" MAKVISION		1
***201	029-B00408	M4X8 SKT BH PAS		8
***202	060-F00400	M4 WSHR FORM A FLT PAS		8

①⑦ ASSY MASK GUN SENSE UPPER (HDZ-1210UK)

(D-1/1)

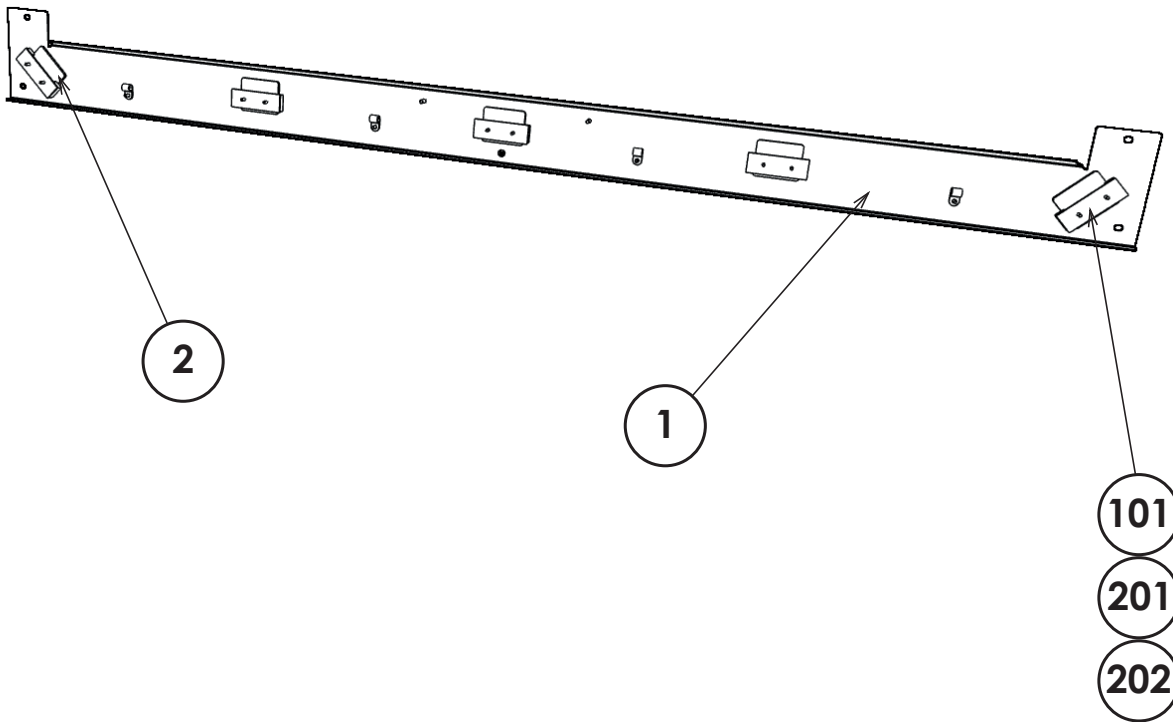

ITEM NO	PART NO	DESCRIPTION	REFERENCE	QTY
***1	HDZ-1211UK	MASK GUN SENSE		1
***2	LMA-7142UK	LED FILTER PLATE		5
***101	838-19185	LED BD G-SENSE HDZ		5
***102	OS1249	P CLIP 6.5MM		4
***201	050-U00300	M3 NUT NYLOK PAS		14
***202	280-L008080-OS	STANDOFF 7.94OD 4.93ID 7.94L		10
***301	HDZ-60018UK	WH LED G SENSE 2		4

⑱ ASSY MASK GUN SENSE LOWER (HDZ-1220UK)

(D-1/1)

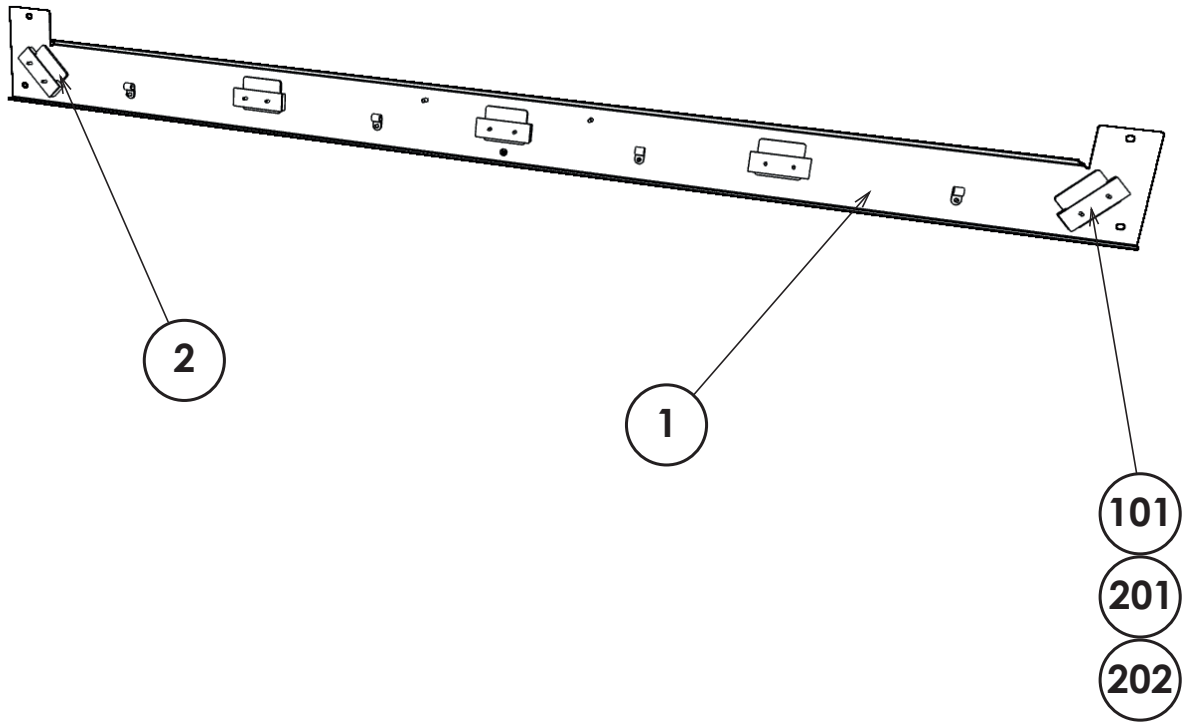

ITEM NO	PART NO	DESCRIPTION	REFERENCE	QTY
***1	HDZ-1211UK	MASK GUN SENSE		1
***2	LMA-7142UK	LED FILTER PLATE		5
***101	838-19185	LED BD G-SENSE HDZ		5
***102	OS1249	P CLIP 6.5MM		4
***201	050-U00300	M3 NUT NYLOK PAS		14
***202	280-L008080-OS	STANDOFF 7.94OD 4.93ID 7.94L		10
***301	HDZ-60018UK	WH LED G SENSE 2		1
***302	HDZ-60018UK	WH LED G SENSE 2		3

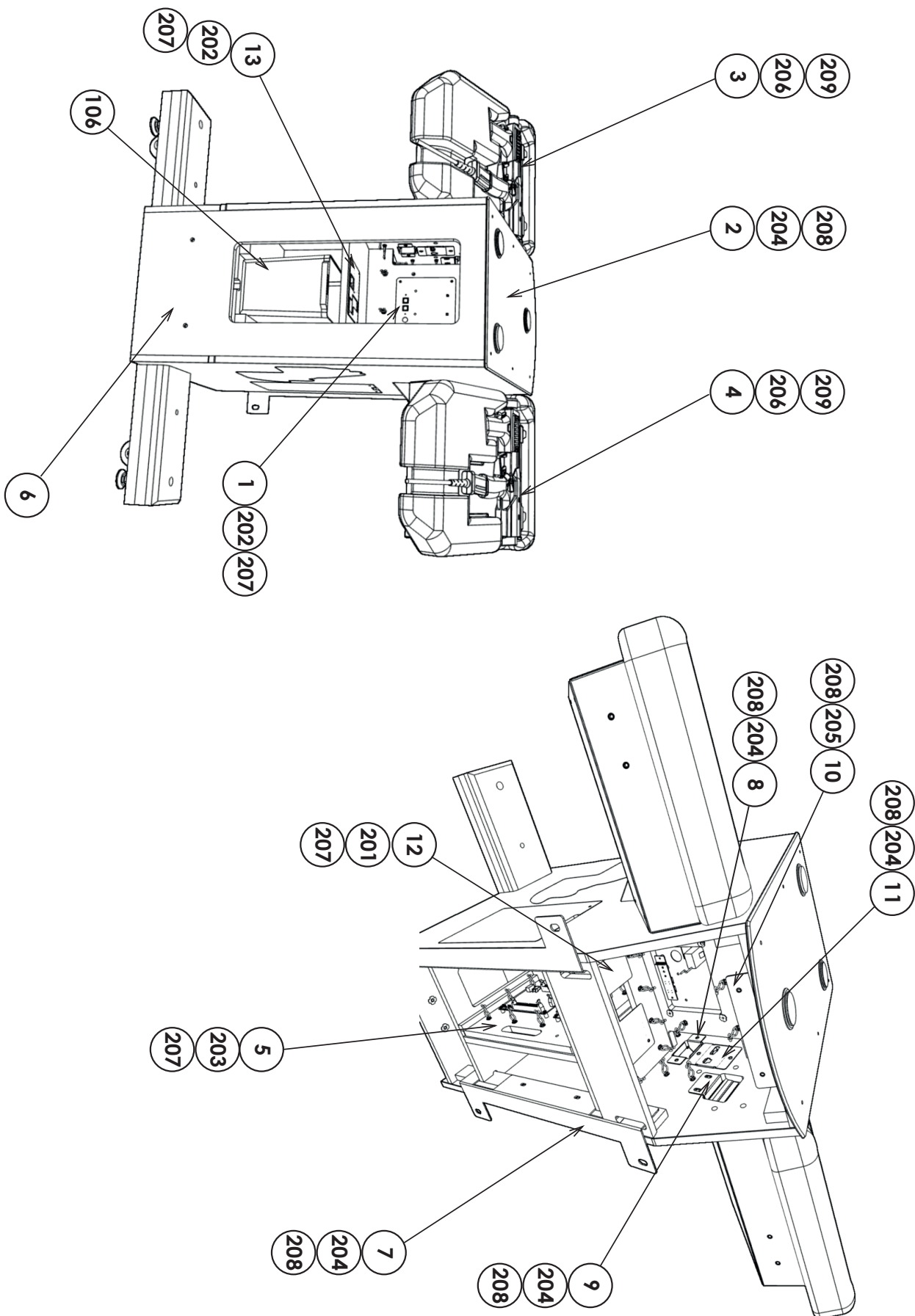

19 ASSY CONTROL CABI (HDZ-2000UK)

(D-2/2)

ITEM NO	PART NO	DESCRIPTION	REFERENCE	QTY
**1	HDZ-0320UK	ASSY SWITCH UNIT		1
**2	HDZ-2200UK	ASSY CONTROL PANEL		1
**3	HDZ-2300UK	ASSY CONTROLLER L		1
**4	HDZ-2350UK	ASSY CONTROLLER R		1
**5	HDZ-2400UK	ASSY CTRL CABI ELEC		1
**6	HDZ-2002UK	ASSY CONTROL BASE CABINET		1
**7	HDZ-2003UK	BRKT MOUNT		2
**8	HDZ-2004UK	GUIDE CONTROLLER HOLDER		2
**9	HDZ-2005UK	BRKT CONTROLLER BASE RETAINING		2
**10	HDZ-2006UK	BRKT CONTROL PANEL RETAINING		1
**11	HDZ-2007UK	PLATE CONTROLLER PNL MOUNT		2
**12	HDZ-2008UK	PLATE COVER		1
**13	DUT-0302UK	PLATE COIN PATH		1
**14	HDZ-5100-01UK	CTRL CABI LH CHEEK STICKER		1
**15	HDZ-5101-01UK	CTRL CABI RH CHEEK STICKER		1
**101	220-5374-01	DOOR DFMD W/FR&LOCK C120 UNIV		1
**102	220-5575UK	LOCK (J9117) KEY TO LIKE 22MM W CAM		1
**103	OS1247	ALUMINIUM STICKY CLIP ASK-3		3
**104	220-5727-01B	DOOR CASH H.S. STS		1
**105	280-A012640-WX	ROUTER TWIST D12 SO6.4 WOOD XL		25
**106	PP1087	BOX CASH		1
**201	029-B00412	M4X12 SKT BH PAS		4
**202	029-B00416	M4X16 SKT BH PAS		9
**203	029-B00430	M4X30 SKT BH PAS		1
**204	029-B00612	M6X12 SKT BH PAS		24
**205	029-B00625	M6X25 SKT BH PAS		2
**206	029-B00830	M8X30 SKT BH PAS		10
**207	068-441616	M4 WSHR 16OD FLT PAS		14
**208	068-652016	M6 WSHR 20OD FLT PAS		26
**209	068-852216	M8 WSHR 22OD FLT PAS		10

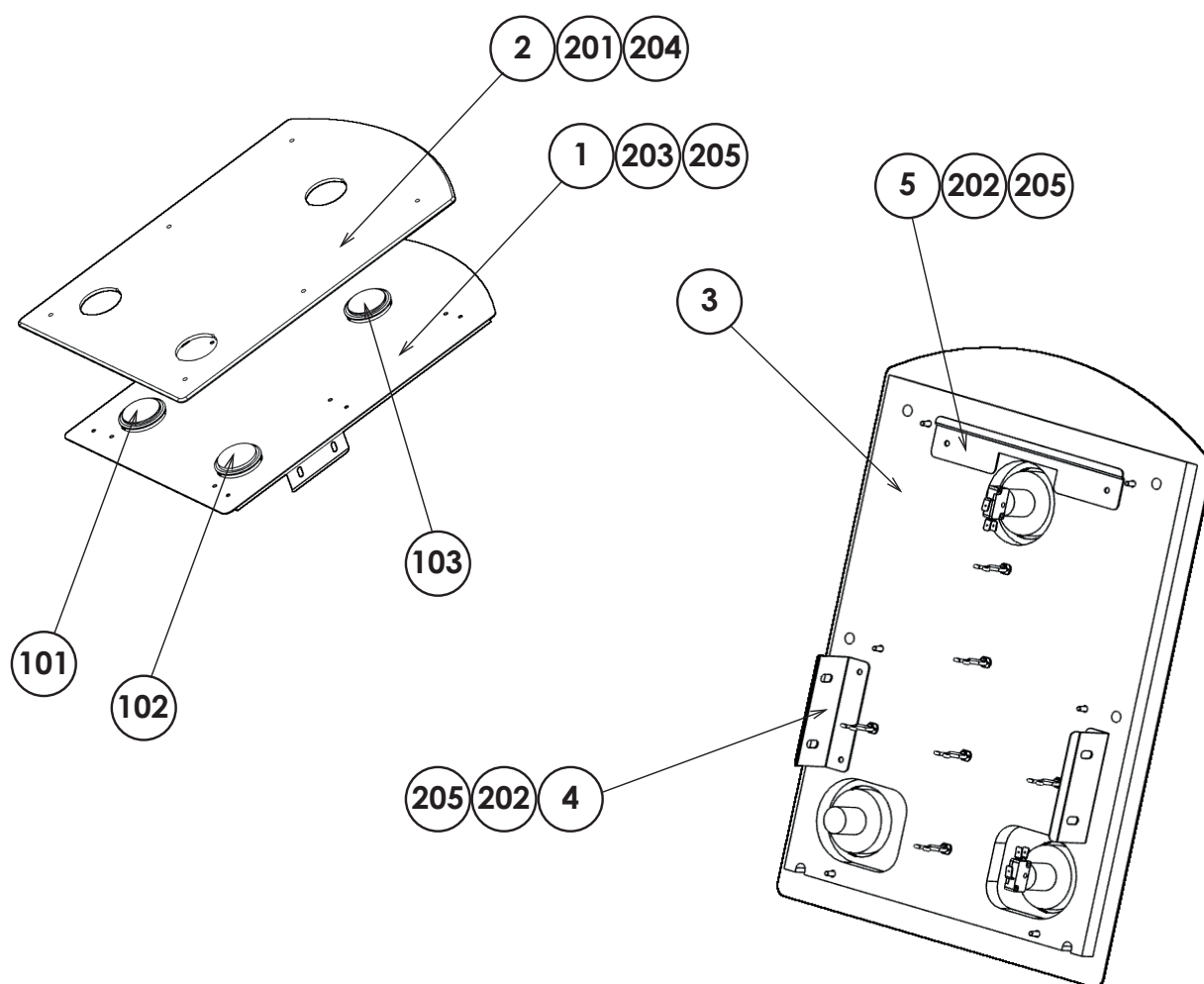

ITEM NO	PART NO	DESCRIPTION	REFERENCE	QTY
***1	HDZ-2201UK	BASE CONTROL PANEL		1
***2	HDZ-5112-01UK	PLATE CONTROL PANEL		1
***3	HDZ-2203UK	BOARD CONTROL PANEL		1
***4	HDZ-2206UK	BRKT LOCATING		2
***5	HDZ-2207UK	BRKT FRONT SECURING		1
***6	HDZ-2208UK	BTN LEGEND VOLUME ON/OFF		1
***101	509-0001-BL	BTN 12V-1.2W BLU S'POINT CPBL		1
***102	509-0001-RE	BTN 12V-1.2W RED S'POINT CPBL		1
***103	509-0001-CLR	BTN 12V-1.2W CLR S'POINT CPBL		1
***104	280-A012640-WX	ROUTER TWIST D12 SO6.4 WOOD XL		6
***201	029-B00412	M4X12 SKT BH PAS		6
***202	029-B00416	M4X16 SKT BH PAS		6
***203	050-F00400	M4 NUT FLG SER PAS		6
***204	060-F00400	M4 WSHR FORM A FLT PAS		6
***205	068-441616	M4 WSHR 16OD FLT PAS		12
***301	HDZ-60025UK	WH CONTROL PANEL		1

21 ASSY CONTROLLER L (HDZ-2300UK)

(D-1/1)

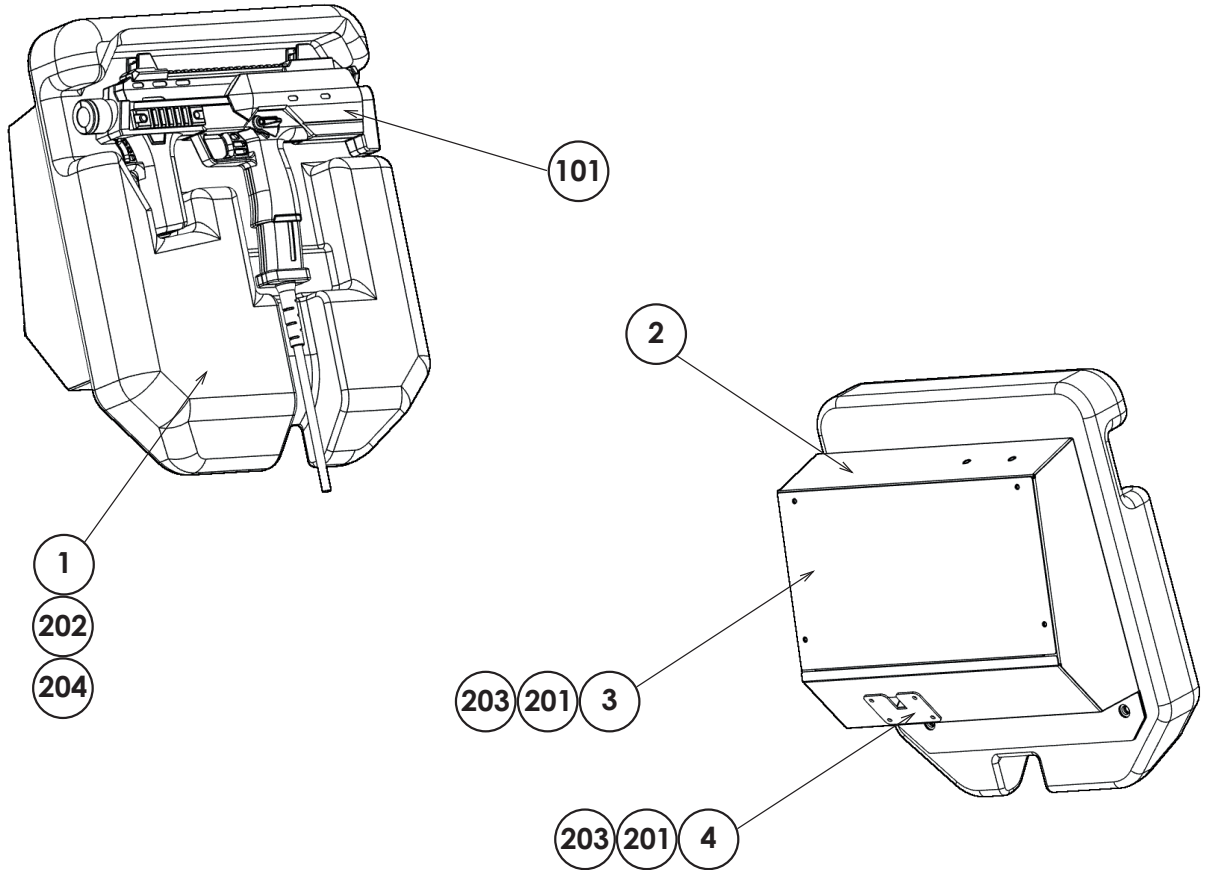

ITEM NO	PART NO	DESCRIPTION	REFERENCE	QTY
***1	HDZ-2301	CTRL HOLDER FRP		1
***2	HDZ-2302UK	CONTROLLER HOLDER BASE LH		1
***3	HDZ-2303UK	CONTROLLER HOLDER BASE LID		1
***4	HDF-1004UK	CONTROLLER CABLE BRKT		1
***5	HDZ-5130-01UK	CTRL HOLDER STICKER		1
***101	HDZ-2100-01	CONTROL UNIT HDZ		1
***102	601-0460	CABLE TIE 100MM		4
***201	029-B00412-0B	M4X12 SKT BH BLK		8
***202	029-B00820-0B	M8X20 SKT BH BLK		4
***203	060-F00400-0B	M4 WSHR FORM A FLT BLK		8
***204	060-F00800-0B	M8 WSHR FORM A FLT BLK		4
***301	HDZ-60027UK	WH CONT HOLDER LED		1
***302	390-2012-025RGB	LED FLX STRIP RGB 250MM		2
***303	BE-6001UK	ASSY LED CLIP		2

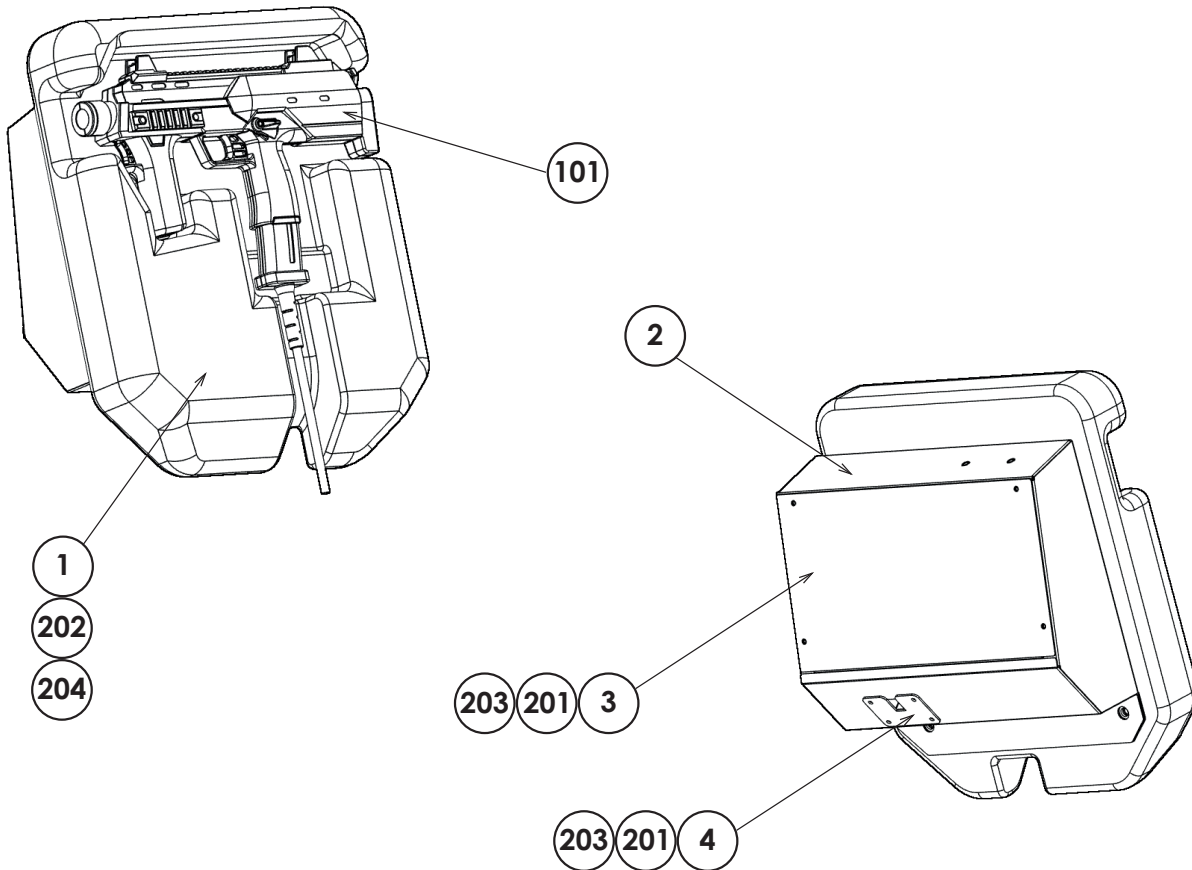

ITEM NO	PART NO	DESCRIPTION	REFERENCE	QTY
***1	HDZ-2301	CTRL HOLDER FRP		1
***2	HDZ-2302UK	CONTROLLER HOLDER BASE RH		1
***3	HDZ-2303UK	CONTROLLER HOLDER BASE LID		1
***4	HDF-1004UK	CONTROLLER CABLE BRKT		1
***5	HDZ-5130-01UK	CTRL HOLDER STICKER		1
***101	HDZ-2100-01	CONTROL UNIT HDZ		1
***102	601-0460	CABLE TIE 100MM		4
***201	029-B00412-0B	M4X12 SKT BH BLK		8
***202	029-B00820-0B	M8X20 SKT BH BLK		4
***203	060-F00400-0B	M4 WSHR FORM A FLT BLK		8
***204	060-F00800-0B	M8 WSHR FORM A FLT BLK		4
***301	HDZ-60027UK	WH CONT HOLDER LED		1
***302	390-2012-025RGB	LED FLX STRIP RGB 250MM		2
***303	BE-6001UK	ASSY LED CLIP		2

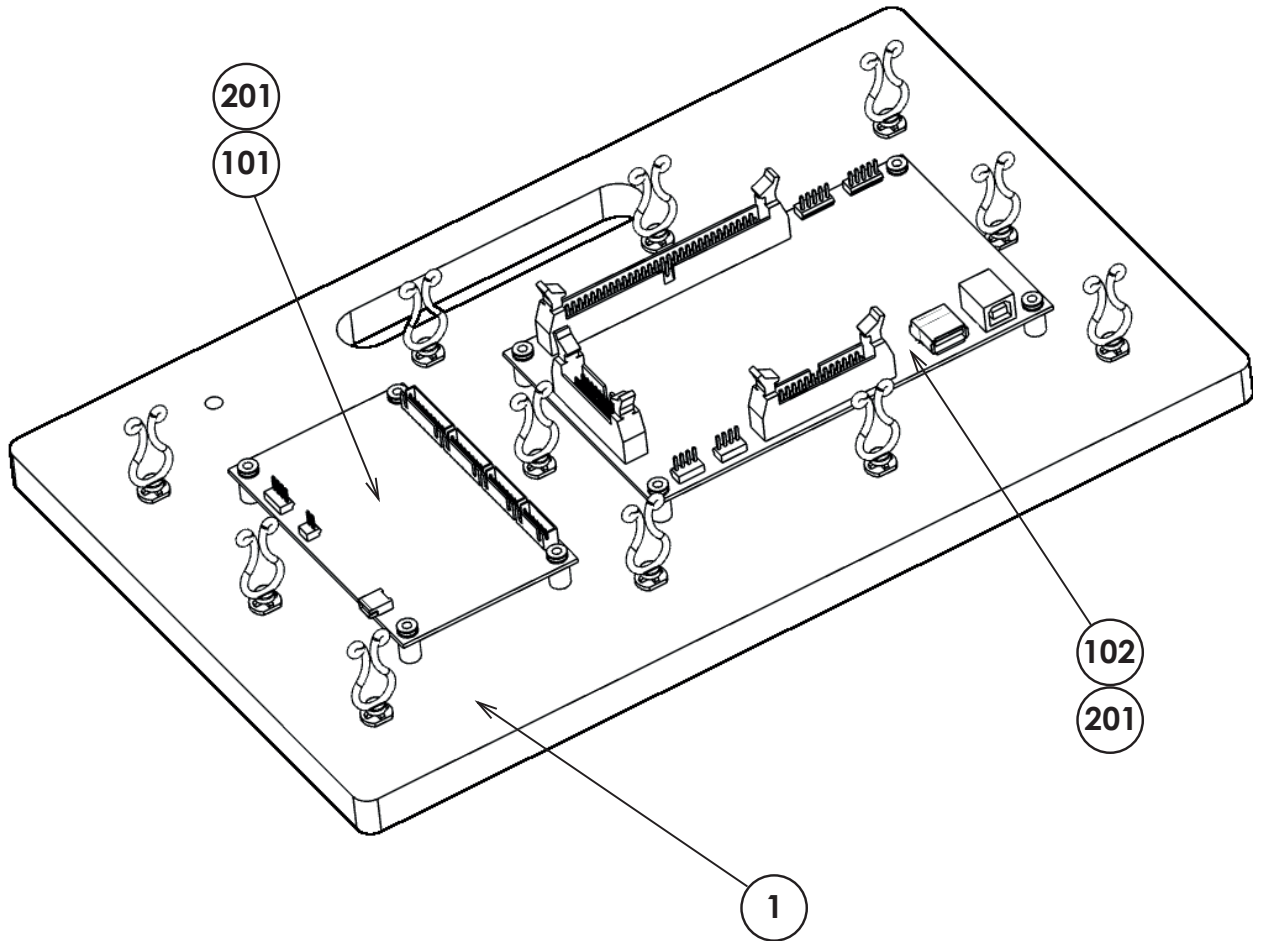

ITEM NO	PART NO	DESCRIPTION	REFERENCE	QTY
***1	HDZ-2401UK	BOARD CTRL CABI ELEC		1
***101	837-15067-02	IC BD USB TO SERIAL 232 IF		1
***102	837-15257-01	I/O CONTROL BD 4		1
***103	280-A012640-WX	ROUTER TWIST D12 SO6.4 WOOD X		11
***201	012-P00325	N4X1" S/TAP PAN PAS		8
***301	HDZ-60023UK	WH CTRL CABI DC		1
***302	HDZ-60024UK	WH CTRL CABI IO		1

24 ASSY REAR CABI (HDZ-3000UK)

(D-1/2)

7 PARTS LIST

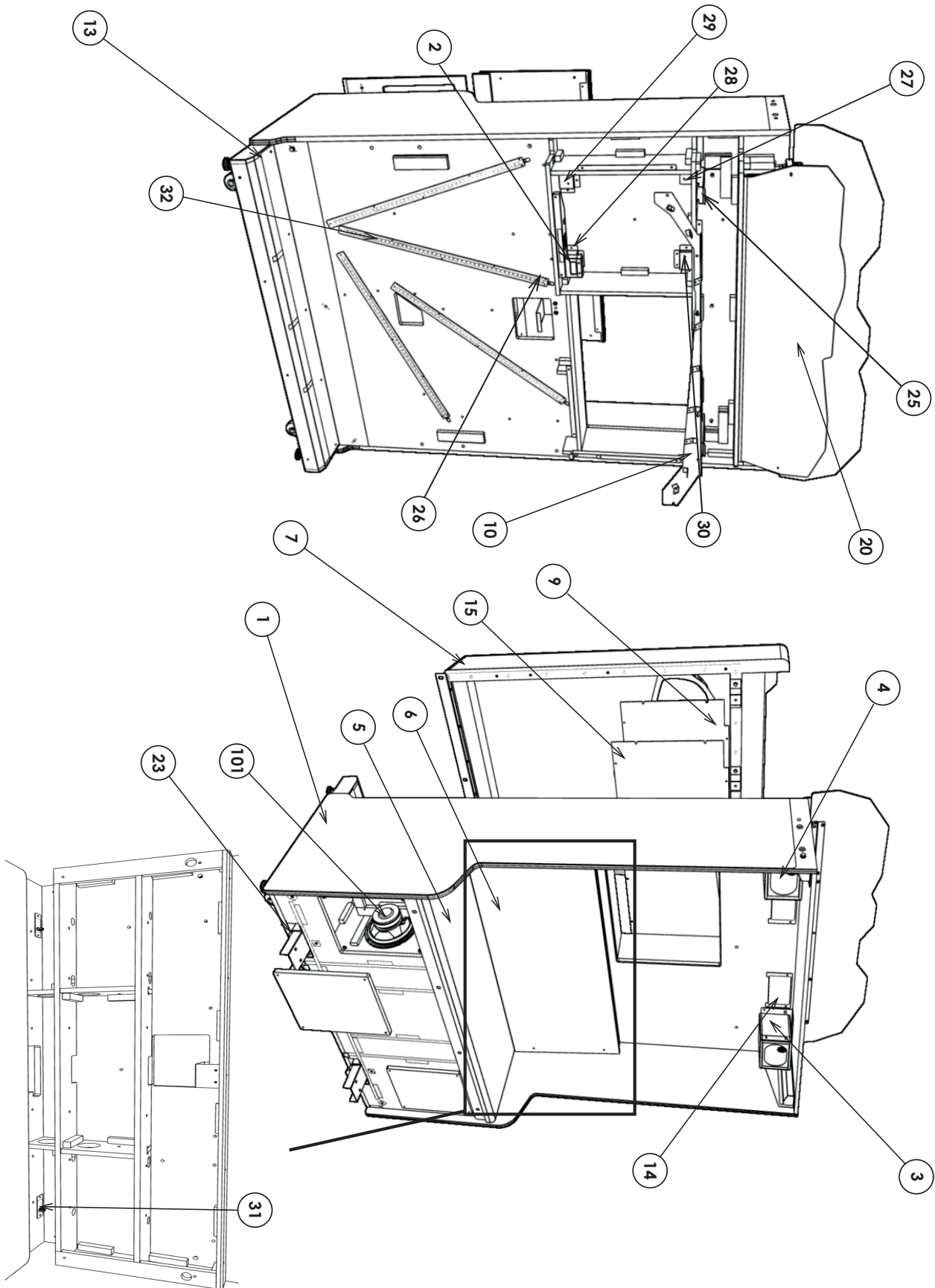

24 ASSY REAR CABI (HDZ-3000UK)

(D-2/2)

ITEM NO	PART NO	DESCRIPTION	REFERENCE	QTY
**1	HDZ-3002UK	ASSY REAR CABINET		1
***2	HDZ-3002-BUK	DOOR WOOFER		2
***3	HDZ-3002-DUK	BRKT WINDOW		3
***4	HDZ-3002-EUK	BRKT WINDOW UPPER		2
***5	117-0001UK	PLATE NUT M8 SINGLE		9
***7	DA-0001UK	ADJUSTER PLATE		4
***101	601-5699UK-01	LEG ADJ M16X100 1L/NUT		4
***102	~	CASTOR 2.5"		4
***103	~	T-EDGE (BLACK)		~
***104	~	T-EDGE (WHITE)		~
***201	030-00625-S	M6X25 BLT W/S PAS		24
***202	060-F00600	M6 WSHR FORM A FLT PAS		24
***203	012-P00412-FB	N8X1/2" S/TAP FLG BLK		33
**2	HDZ-3500UK	ASSY OBJECT LED		8
**3	HDZ-3800UK	ASSY SPEAKER REAR L		1
**4	HDZ-3850UK	ASSY SPEAKER REAR R		1
**5	HDZ-3600UK	ASSY SEAT BTM		1
**6	HDZ-3400UK	ASSY BACKREST		1
**7	HDZ-3700UK	ASSY REAR MOULDING		1
**8	HDZ-1531	OBJECT FRP		1
**9	HDZ-5512-02UK	REAR WINDOW		1
**10	HDZ-3023XUK	BRKT UPR LED REAR COVER		1
**13	HDZ-3008UK	BASE COVER		1
**14	HDZ-3013UK	PLATE LID BILLBOARD		2
**15	HDZ-5512-03UK	REAR WINDOW BACK		1
**18	HDZ-5305-01UK	STICKER REAR CABI LH SIDE FULL		1
**19	HDZ-5306-01UK	STICKER REAR CABI RH SIDE FULL		1
**20	HDZ-0600UK	ASSY BILLBOARD SDX		1
**23	HDZ-3003UK	JOINT BRIDGE HOLDER		2
**24	HDZ-3007UK	BRKT CONN ROOF		1
**25	HDZ-3014UK	BRKT FRP GUIDE UPR		2
**26	HDZ-3015UK	BRKT EYE WH GUIDE		1
**27	HDZ-3017UK	BRKT OBJECT UPPER L		1
**28	HDZ-3018UK	BRKT OBJECT LOWER R		1
**29	HDZ-3019UK	BRKT OBJECT LOWER L		1
**30	HDZ-3020UK	BRKT OBJECT UPPER R		1
**31	HDZ-3021UK	PLATE WOOFER PANEL MTG		2
**32	HDZ-3022UK	COVER LED REAR		4
**101	130-5313	WOOFER 7OHM 100W 20CM		2
**301	HDZ-60036UK	WH REAR GIMMICK		1
**303	HDZ-60031UK	WH BASS SHAKER SEAT		1
**304	HDZ-60040UK	WH REAR COVER LED		1
**305	HDZ-60039UK	WH SEAT CABI SPEAKER		1
**306	HDZ-60050UK	WH SPEAKER		2
**307	BE-6001UK	ASSY LED CLIP		4
**308	390-2012-080RGB	LED FLX STRIP RGB 800MM		4

25 ASSY BACKREST (HDZ-3400UK)

(D-1/1)

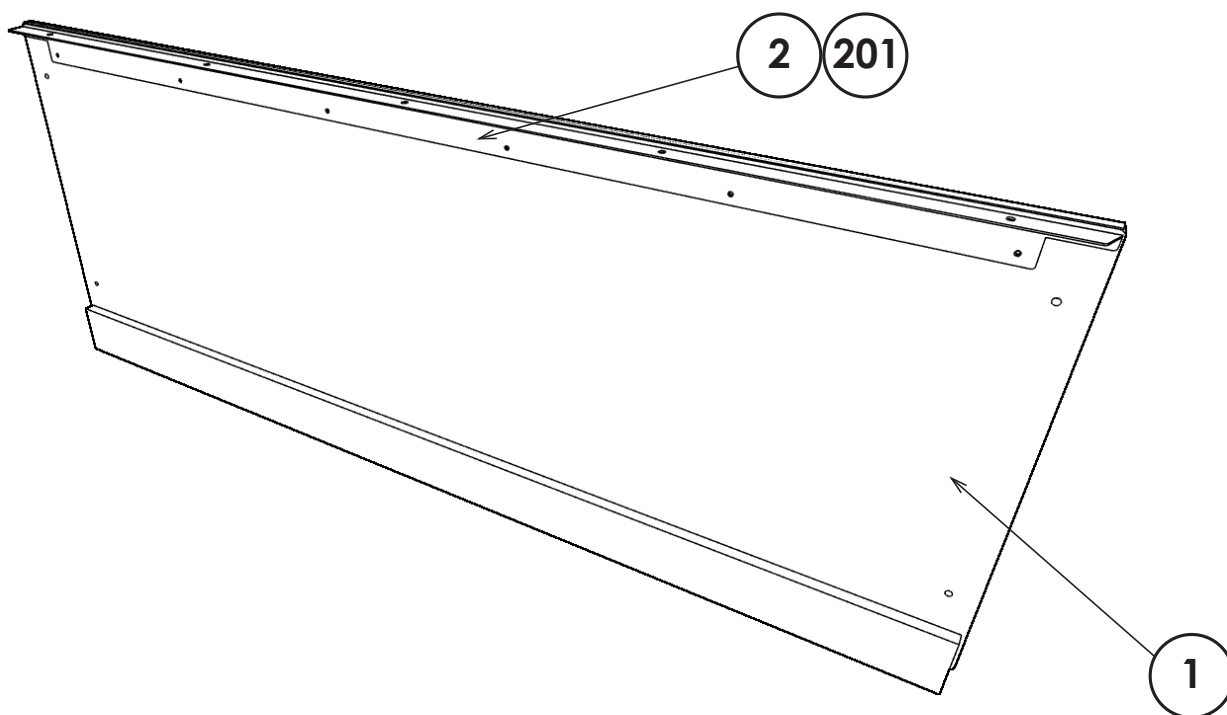

ITEM NO	PART NO	DESCRIPTION	REFERENCE	QTY
***1	HDZ-3401UK	PANEL SEAT BACK		1
***2	HDZ-3402UK	BRKT SEAT BACK		1
***5	HDZ-5310-01UK	STICKER BACKREST		2
***201	012-P00412-FB	N8X1/2" S/TAP FLG BLK		6

26 ASSY OBJECT LED (HDZ-3500UK)

(D-1/1)

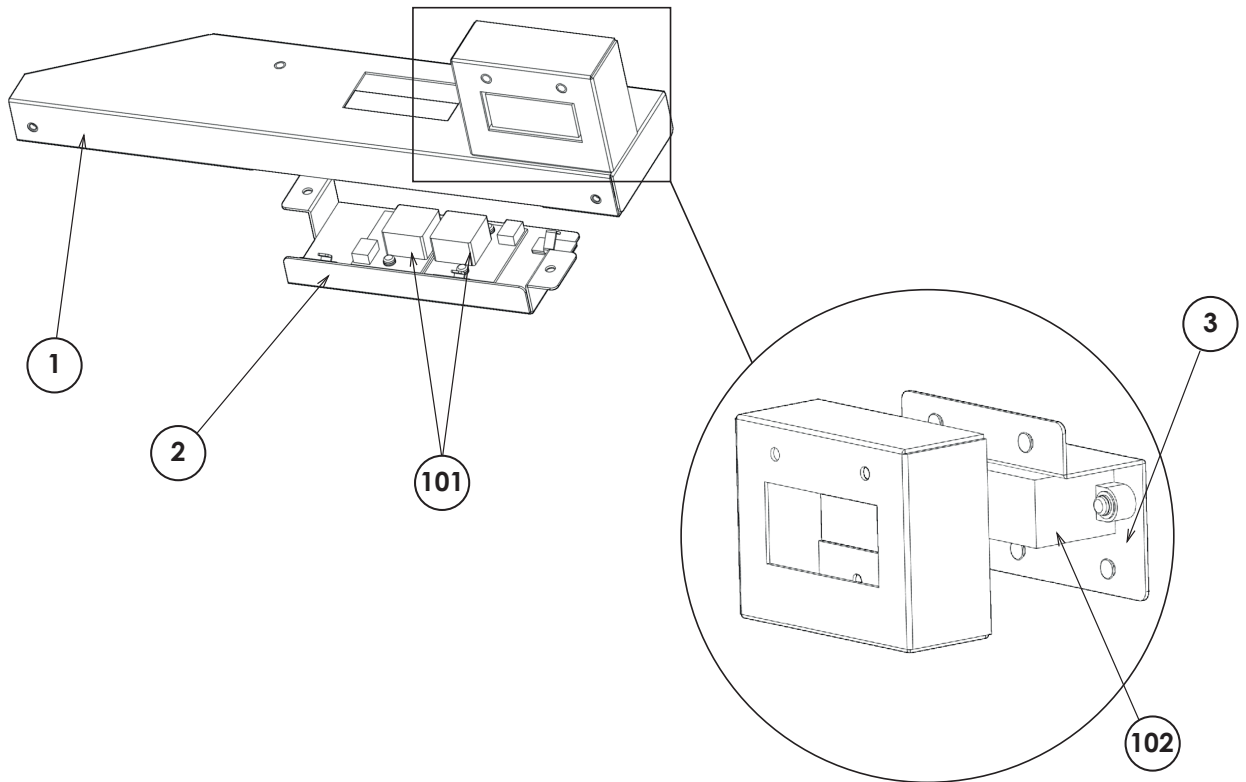

ITEM NO	PART NO	DESCRIPTION	REFERENCE	QTY
***1	HDZ-3501UK	BASE OBJECT LED		1
***2	HDZ-3503UK	BRKT OBJECT LED		1
***3	HDZ-3502UK	BRKT SNSR PROXIMITY		1
***101	838-19187	RGB SPOTLIGHT LED BD 5V		2
***102	370-5395	MOTION SENSOR AMBA345208		1
***301	HDZ-60038UK	WH REAR LED		1
***302	HDZ-60034UK	WH SPOT LIGHT		1

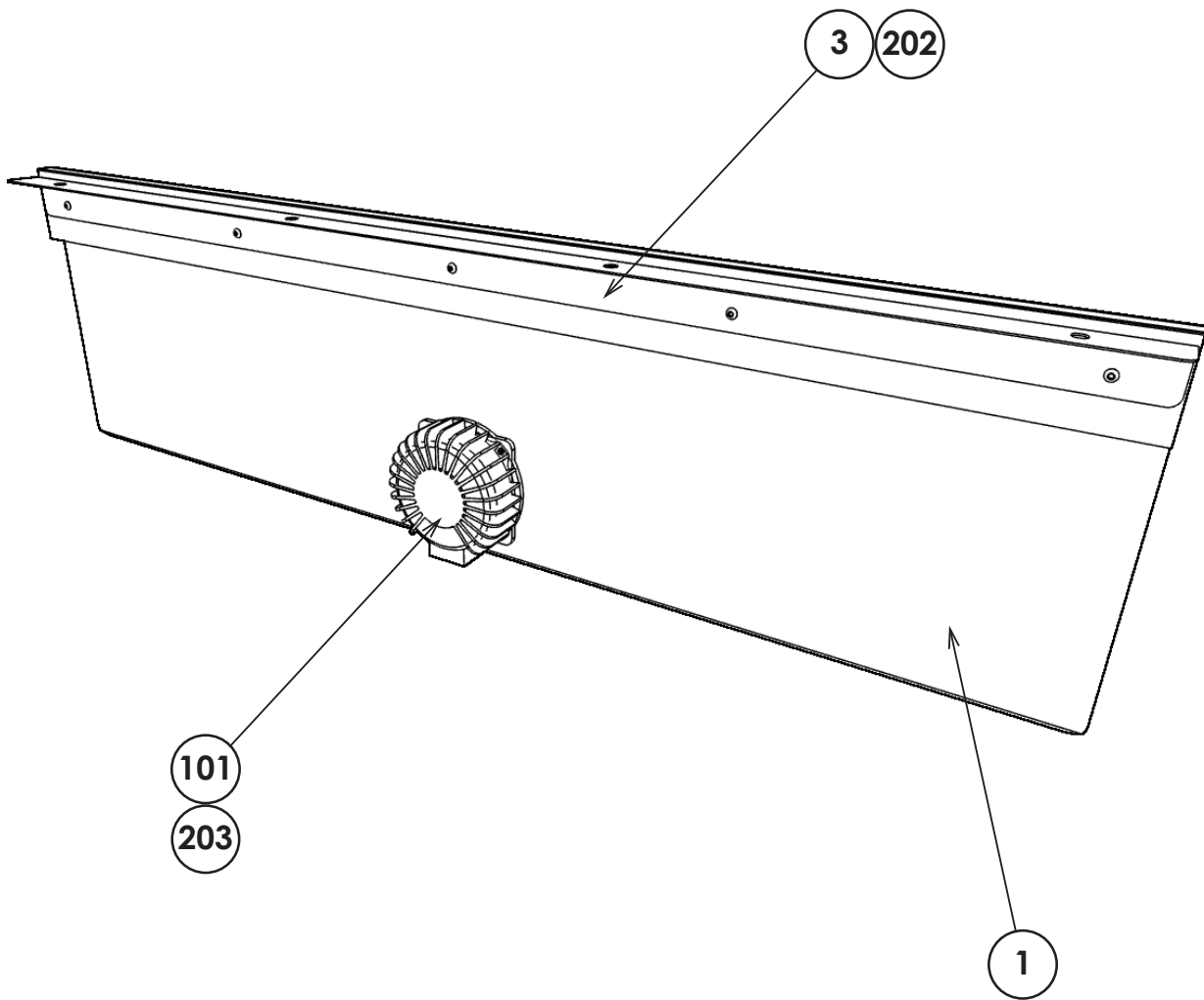

ITEM NO	PART NO	DESCRIPTION	REFERENCE	QTY
***1	HDZ-3601UK	ASSY SEAT WOOD		1
***3	HDZ-3603UK	SEAT FIX BRKT		1
***101	130-5314	BASS SHAKER ACT-50-4		1
***202	029-B00625-0B	M6X25 SKT BH BLK		5
***203	012-P00412-FB	N8x1/2" S/TAP FLG BLK		4
***301	HDZ-60031UK	WH BASS SHAKER SEAT		1

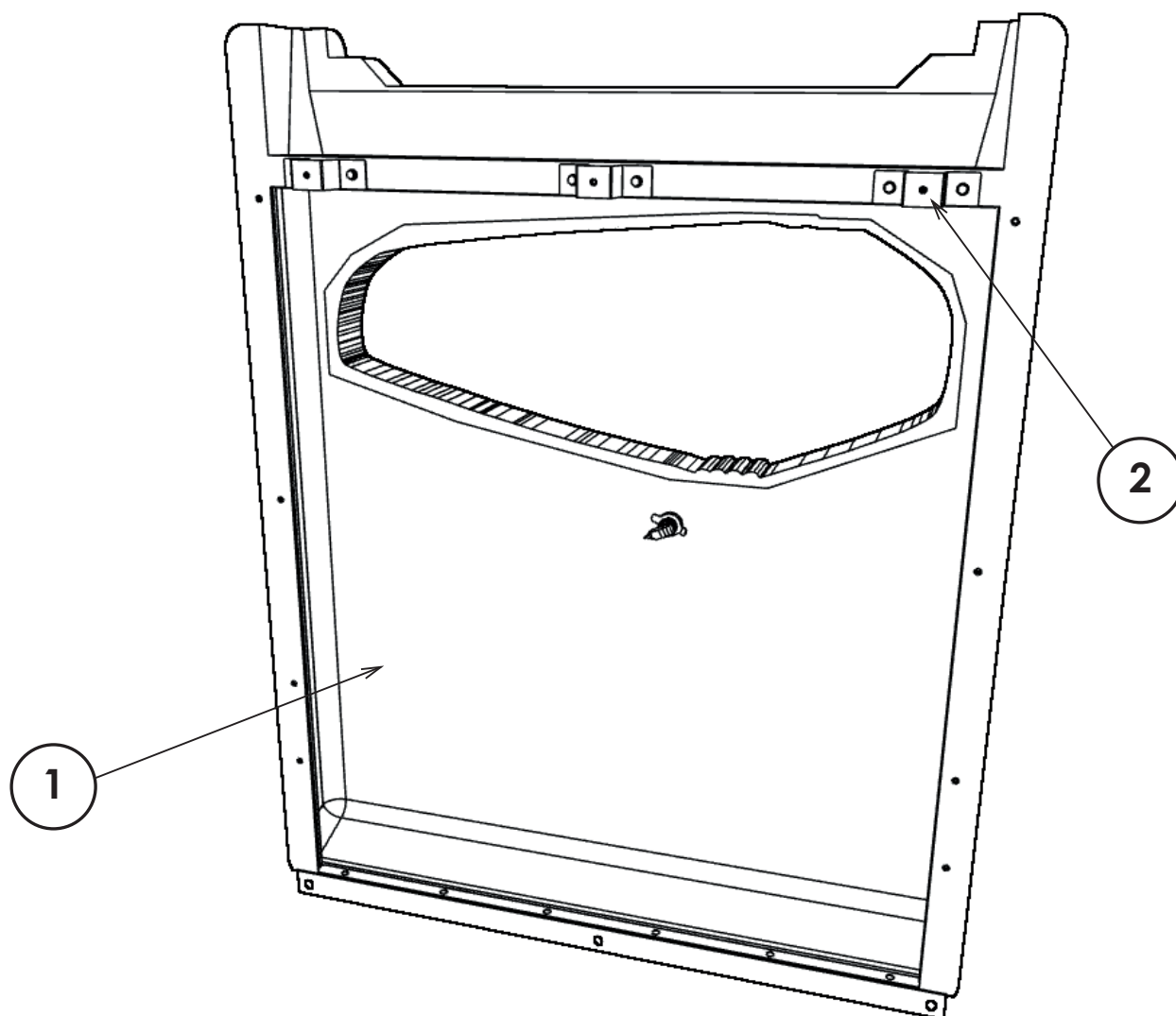

ITEM NO	PART NO	DESCRIPTION	REFERENCE	QTY
***1	HDZ-1610	REAR COVER		1
***2	HDZ-3703UK	BRKT JOINT REAR COVER		3
***101	509-6466	SW OBSA-30UMQ HDZ EYE		1
***301	HDZ-60041UK	WH EYE SW		1

29 ASSY SPEAKER REAR L (HDZ-3800UK)

(D-1/1)

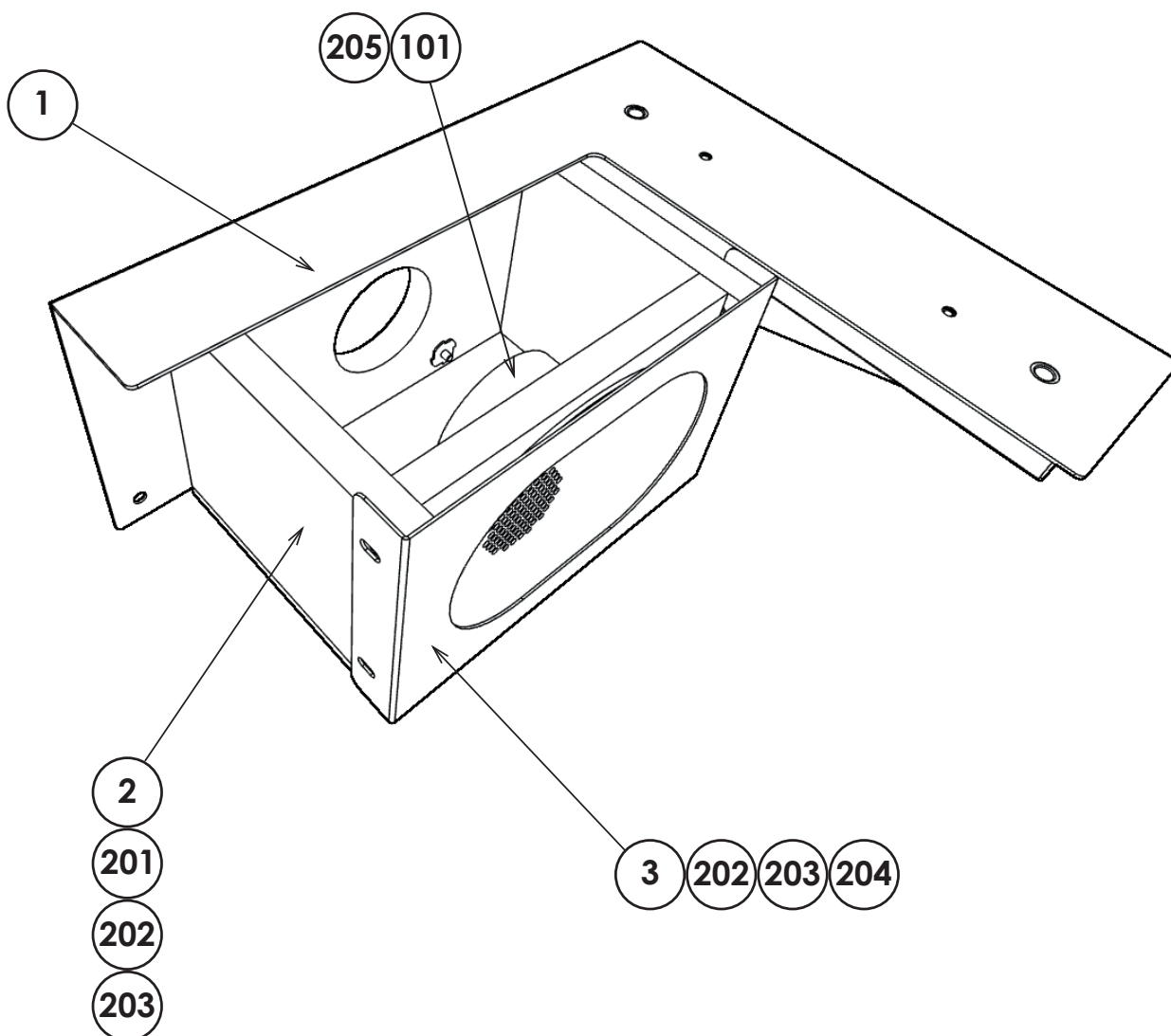

ITEM NO	PART NO	DESCRIPTION	REFERENCE	QTY
***1	HDZ-3005UK	BRKT SPEAKER LEFT		1
***2	HDZ-1022UK	BOX SPEAKER		1
***3	HDZ-1023UK	PLATE SPEAKER COVER		1
***101	130-04030-E	SPKR ELIP 4OHM 30W VIS DX4X6P		1
***201	029-B00425-0B	M4X25 SKT BH BLK		4
***202	068-441616-0B	M4 WSHR 16OD FLT BLK		8
***203	060-S00400-0B	M4 WSHR SPR BLK		8
***204	029-B00416-0B	M4X16 SKT BH BLK		4
***205	012-P00412-FB	N8x1/2" S/TAP FLG BLK		4

30 ASSY SPEAKER REAR R (HDZ-3850UK)

(D-1/1)

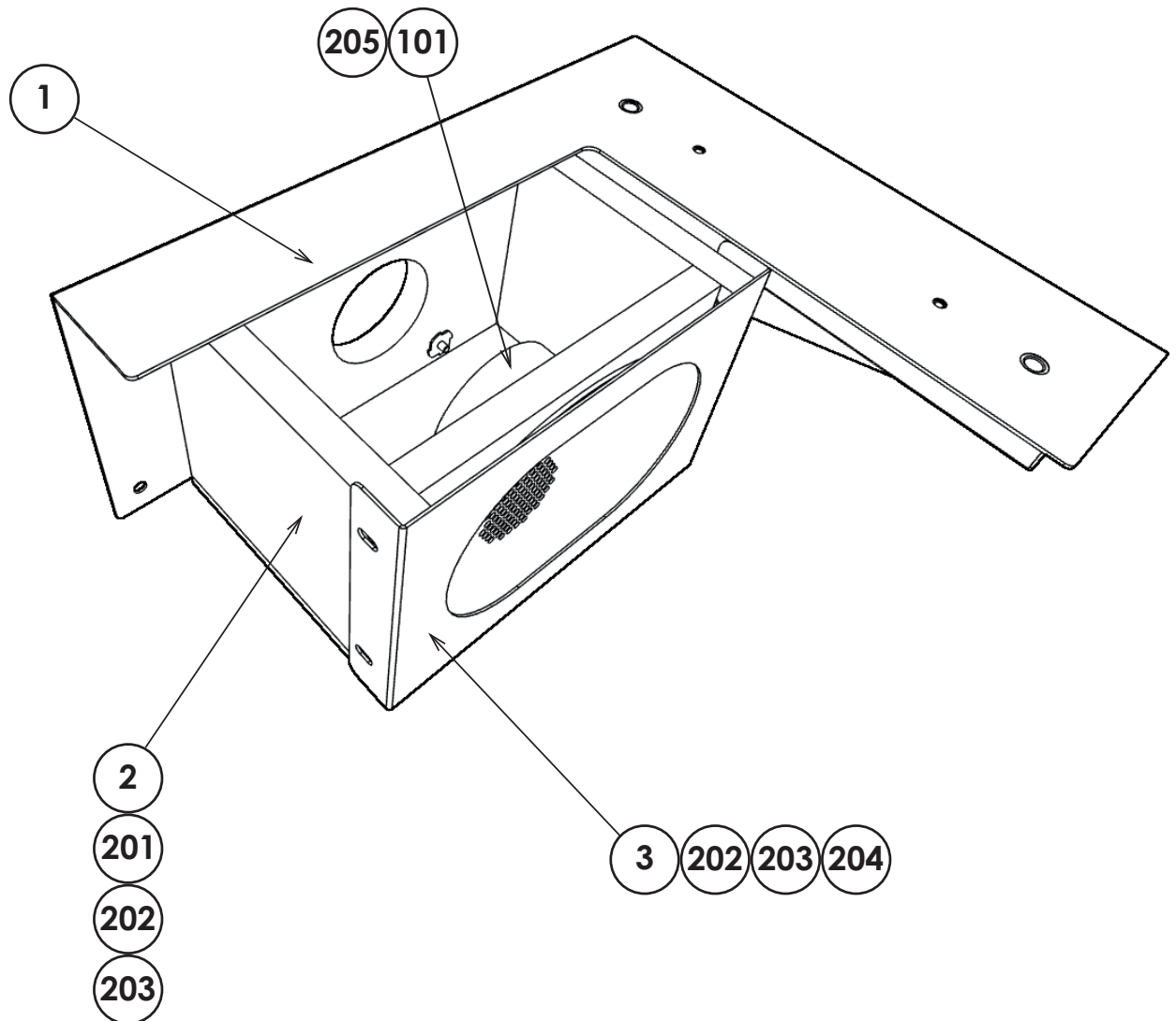

ITEM NO	PART NO	DESCRIPTION	REFERENCE	QTY
***1	HDZ-3005UK	BRKT SPEAKER RIGHT		1
***2	HDZ-1022UK	BOX SPEAKER		1
***3	HDZ-1023UK	PLATE SPEAKER COVER		1
***101	130-04030-E	SPKR ELIP 4OHM 30W VIS DX4X6P		1
***201	029-B00425-0B	M4X25 SKT BH BLK		4
***202	068-441616-0B	M4 WSHR 16OD FLT BLK		8
***203	060-S00400-0B	M4 WSHR SPR BLK		8
***204	029-B00416-0B	M4X16 SKT BH BLK		4
***205	012-P00412-FB	N8x1/2" S/TAP FLG BLK		4

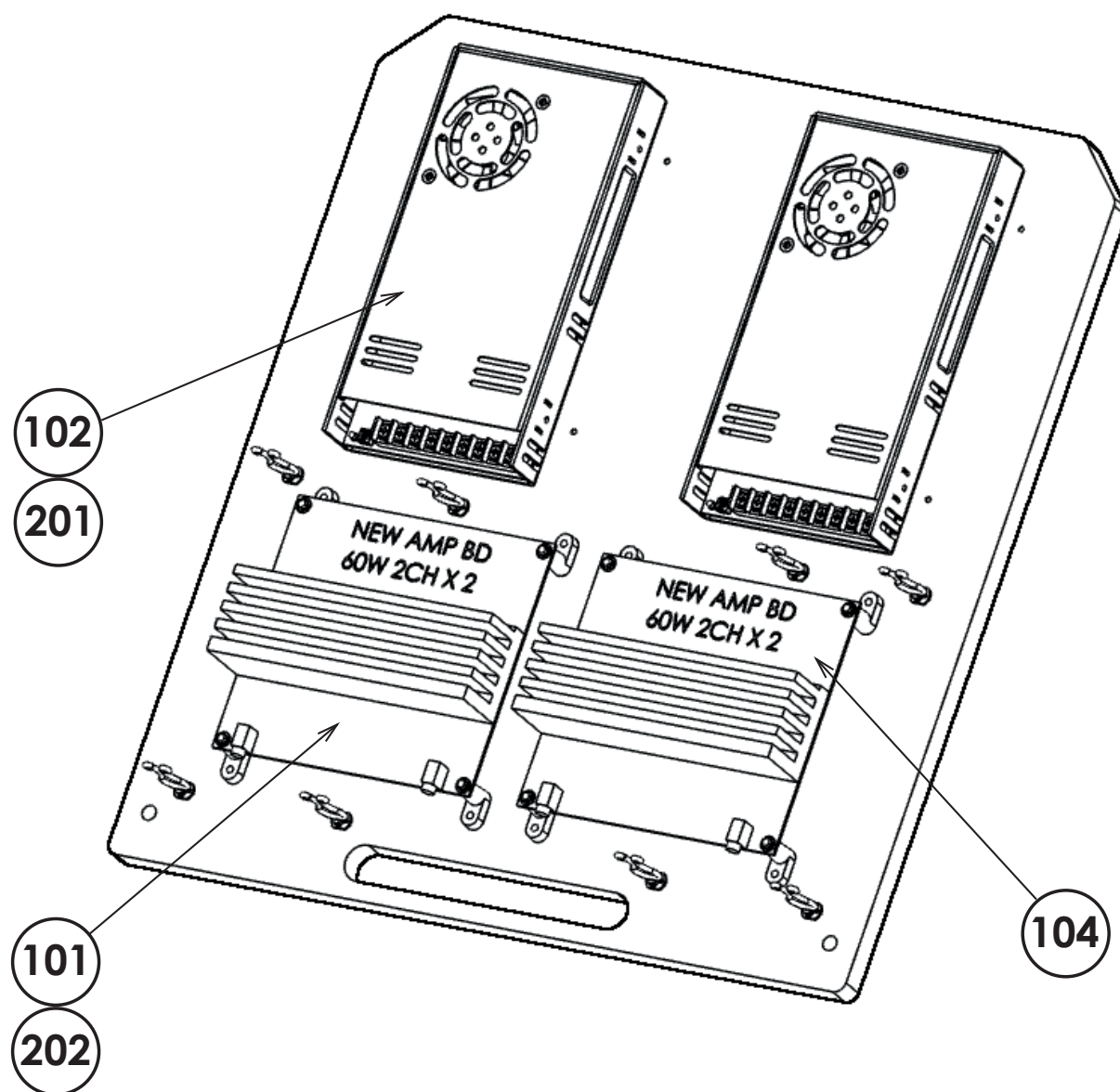

ITEM NO	PART NO	DESCRIPTION	REFERENCE	QTY
**1	HDZ-4001UK	BOARD UPPER ELEC		1
**101	838-19183-01	60-100W AUDIO AMP BD		1
**102	400-320-036	RSP-320 MW 320W 36V SMPSU		2
**103	280-A012640-WX	ROUTER TWIST D12 SO6.4 WOOD X		8
**104	838-19183-02	60-100W AUDIO AMP BD		1
**201	000-P00420	M4X20 MSCR PAN PAS		8
**202	012-P00325	N4X1" S/TAP PAN PAS		8
**301	HDZ-60012UK	WH AMP VOL		2
**302	HDZ-60015UK	WH SPEAKER TH		1
**303	HDZ-60016UK	WH 36V AUDIO TH		2
**304	HDZ-60044UK	WH AUDIO PLUG BRANCH		1

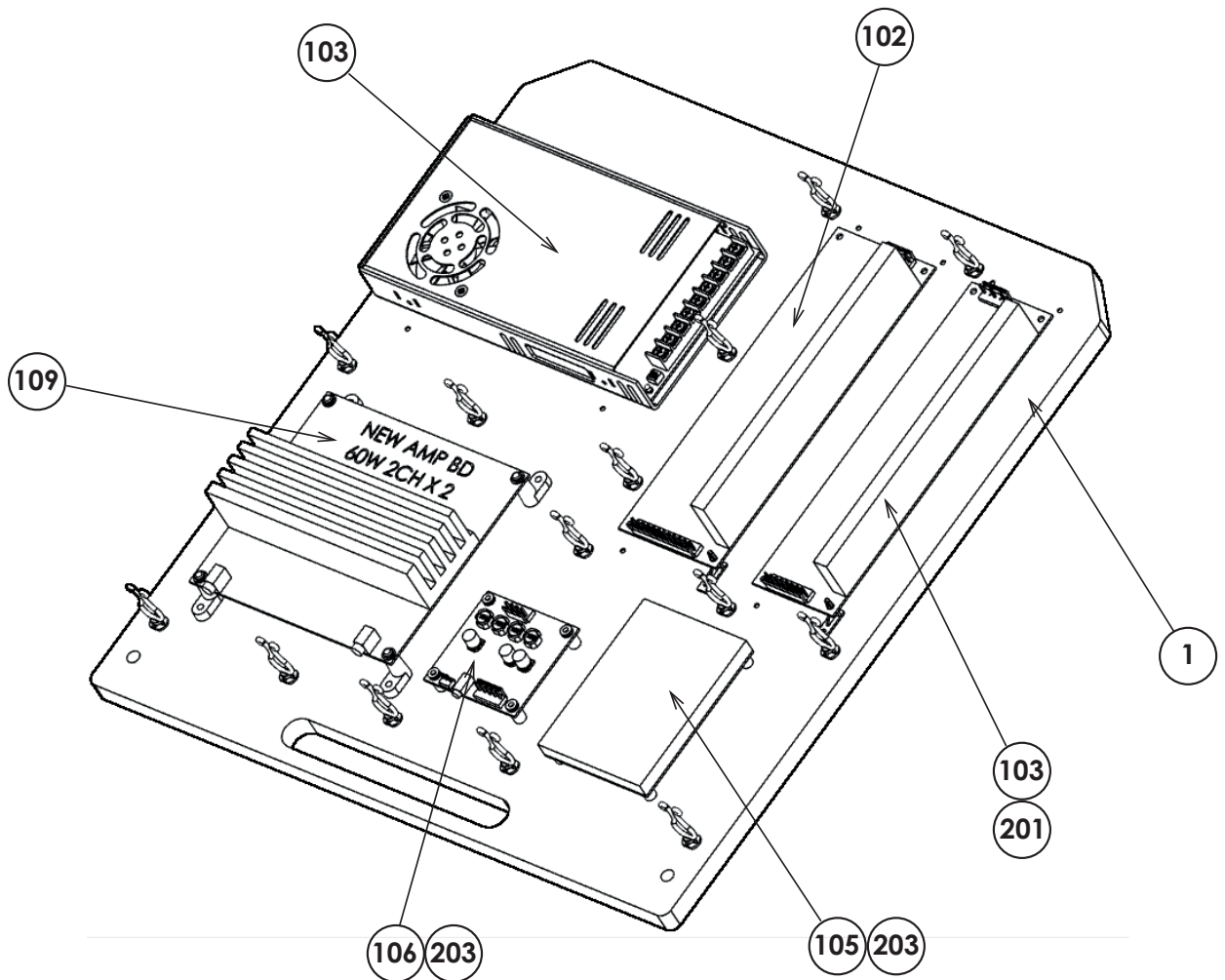

ITEM NO	PART NO	DESCRIPTION	REFERENCE	QTY
***1	HDZ-4101UK	BOARD LOWER ELEC		1
***101	400-150-012-01	PSU 12V 150W LPP-150-12		1
***102	400-100-05-01	PSU 5V 100W MW LPS-100-05		1
***103	400-320-036	RSP-320 MW 320W 36V SMPSU		1
***105	838-19184	IC BD G-SENSE HDZ		1
***106	839-1383	CLASS D 10W STEREO AMP MAXIN		1
***107	OS1011	PCB FEET RICHCO LCBS L-5-01		8
***108	280-A012640-WX	ROUTER TWIST D12 SO6.4 WOOD X		14
***109	838-19183-01	60-100W AUDIO AMP BD		1
***201	000-P00420	M4X20 MSCR PAN PAS		4
***202	012-P00308	N4X5/16" S/TAP PAN PAS		8
***203	012-P00325	N4X1" S/TAP PAN PAS		12

32 ASSY ELEC BOARD LOWER (HDZ-4100UK)

(D-2/2)

***301	HDZ-60006UK	WH AC IN ELEC COM	1
***302	HDZ-60007UK	WH ELEC DC OUT	1
***303	HDZ-60008UK	WH IR LED OUT	1
***304	HDZ-60009UK	WH RS232C G SENSE	1
***305	HDZ-60010UK	WH AMP VOL CONT	1
***306	HDZ-60011UK	WH 36V AUDIO ELEC	1
***307	HDZ-60012UK	WH AMP VOL	1
***308	HDZ-60013UK	WH SPEAKER DX	1
***309	HDZ-60017UK	WH LED G SENSE 1	1
***310	HDZ-60050UK	WH SPEAKER	3

33 ASSY GAME BOARD (HDZ-4200UK)

(D-1/1)

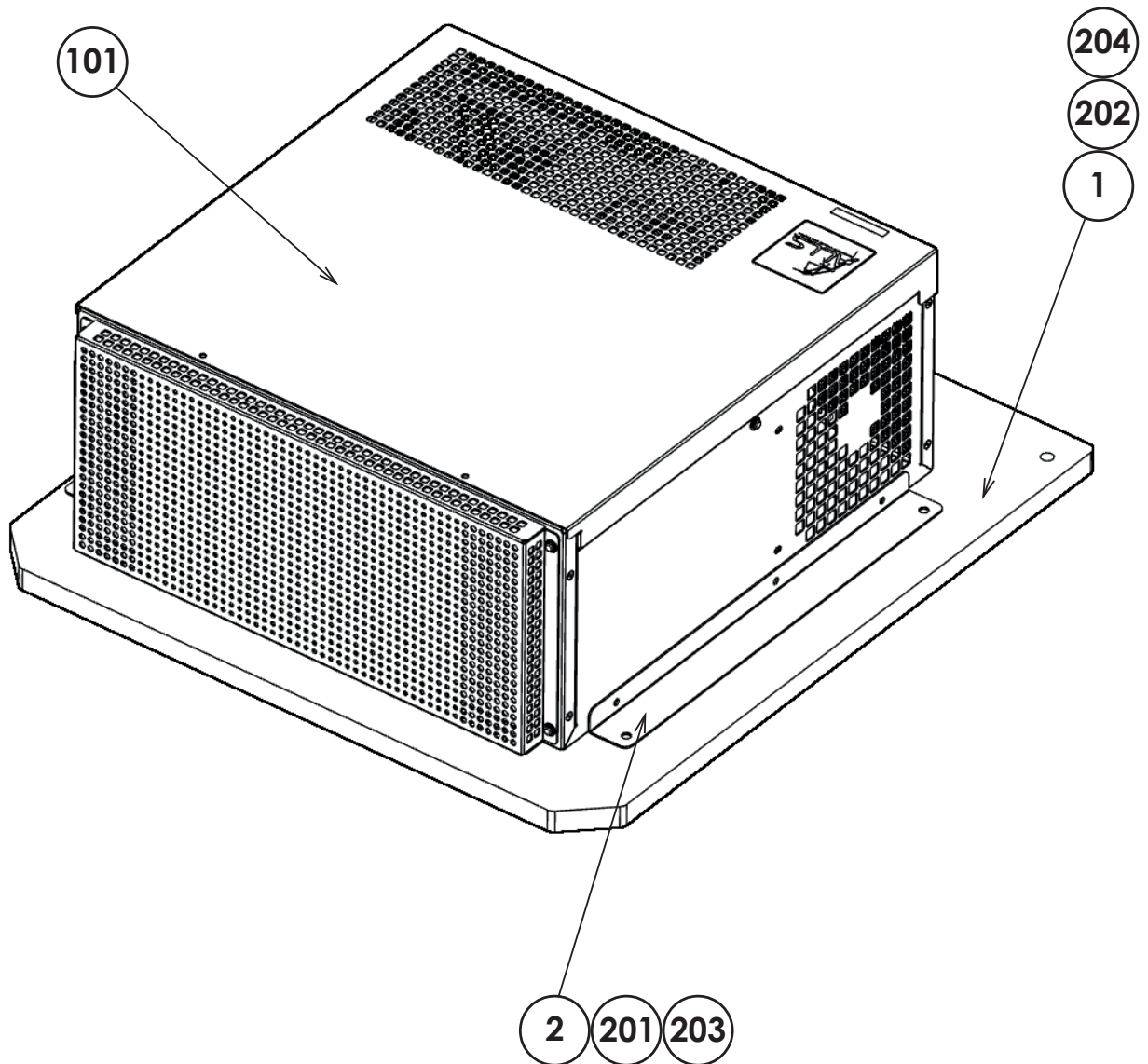

ITEM NO	PART NO	DESCRIPTION	REFERENCE	QTY
***1	HDZ-4201UK	BASE GAMEBOARD		1
***2	HDZ-4202UK	BRKT GAMEBD		2
***101	849-0005	ASSY CASE ALLS UX W S/B		1
***102	610-0XXXX??	KEY CHIP ????		1
***103	280-A012640-WX	ROUTER TWIST D12 SO6.4 WOOD X		1
***201	029-B00412	M4X12 SKT BH PAS		4
***202	029-B00416	M4X16 SKT BH PAS		4
***203	060-F00400	M4 WSHR FORM A FLT PAS		4
***204	068-441616	M4 WSHR 16OD FLT PAS		4
***301	HDZ-60005UK	WH RS232C TO ELEC		1
***302	HDZ-60045UK	WH AUDIO JACK		1
***303	600-7011-0200UK	DA DVI TO DVI 200CM		1

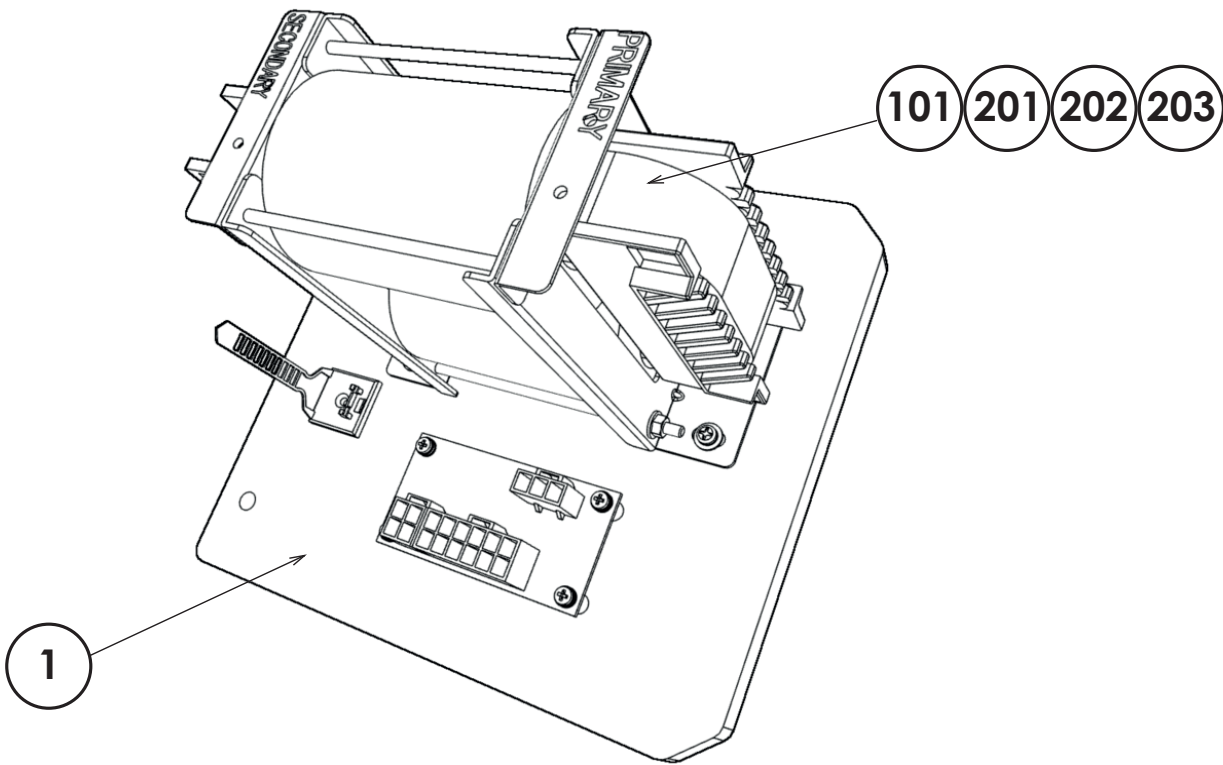

ITEM NO	PART NO	DESCRIPTION	REFERENCE	QTY
***1	HDZ-4301UK	BOARD XFMR		1
***101	560-1111-02UK	XFMR US BLOCK 800VA ST800-11-11		1
***201	029-B00616	M6X16 SKT BH PAS		4
***202	060-S00600	M6 WSHR SPR PAS		4
***203	068-652016	M6 WSHR 20OD FLT PAS		4
***301	HDZ-60002UK	WH XFMR		1

17 PARTS LIST

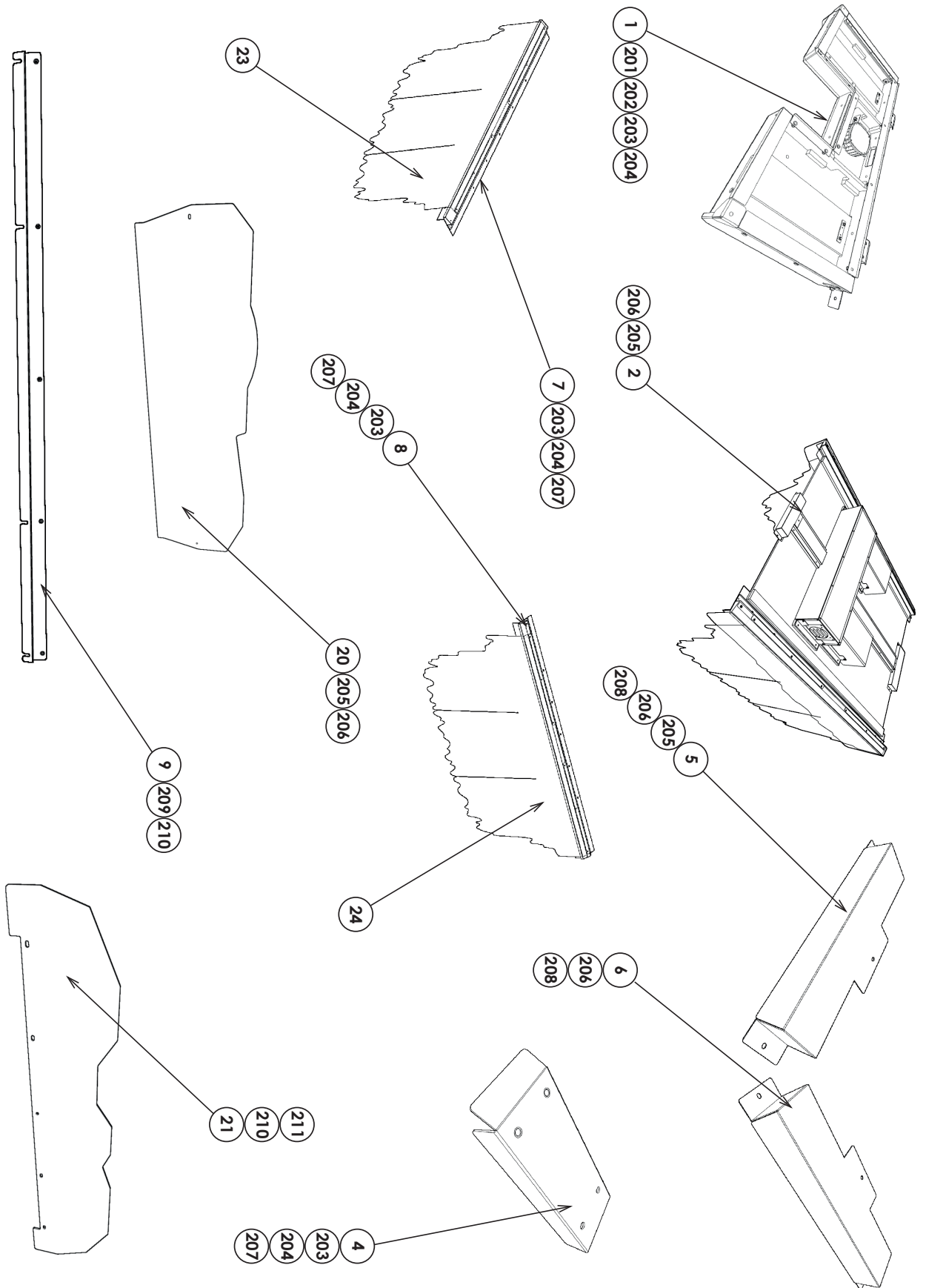

35 ASSY INST HDZ SDX (HDZ-INST-SDX)

(D-2/2)

ITEM NO	PART NO	DESCRIPTION	REFERENCE	QTY
***1	HDZ-0400UK	ASSY STEP		1
***2	HDZ-0500UK	ASSY ROOF SDX		1
***4	HDZ-0051UK	JOINT BRIDGE		2
***5	HDZ-0503UK	BRKT ROOF CONN LID REAR		1
***6	HDZ-0504UK	BRKT ROOF CONN LID FRONT		1
***7	HDZ-0550UK	ASSY CURTAIN L		1
***8	HDZ-0570UK	ASSY CURTAIN R		1
***9	HDZ-0603UK	BRKT POP		1
***20	HDZ-5500-01UK	BILLBOARD PLATE		1
***21	HDZ-5501-02UK	BILLBOARD POP		1
***22	HDZ-5400-01UK	SIDE CURTAIN		2
***23	HDZ-5401-01UK	SUB CURTAIN L		1
***24	HDZ-5402-01UK	SUB CURTAIN R		1
***201	029-B00850-0B	M8X50 SKT BH BLK		2
***202	029-B00825-0B	M8X25 SKT BH BLK		2
***203	060-S00800-0B	M8 WSHR SPR BLK		32
***204	068-852216-0B	M8 WSHR 22OD FLT BLK		32
***205	029-B00416-0B	M4X16 SKT BH BLK		14
***206	068-441616-0B	M4 WSHR 16OD FLT BLK		18
***207	029-B00840-0B	M8X40 SKT BH BLK		24
***208	029-B00412-0B	M4X12 SKT BH BLK		4
***209	029-B00412	M4X12 SKT BH PAS		4
***210	068-441616	M4 WSHR 16OD FLT PAS		9
***211	029-B00408	M4X8 SKT BH PAS		5

18 WIRE COLOR CODE TABLE

⚠ WARNING

The DC power wire color for this product is different from previous SEGA titles. Working from the previous wire colors will create a high risk of fire.

18

WIRE COLOUR CODE TABLE

The color codes for the wires used in the diagrams in the following chapter are as follows.

A	PINK
B	SKY BLUE
C	BROWN
D	PURPLE
E	LIGHT GREEN

Wires other than those of any of the above 5 single colors will be displayed by 2 alphanumeric characters.

1	RED
2	BLUE
3	YELLOW
4	GREEN
5	WHITE
7	ORANGE
8	BLACK
9	GRAY

If the right-hand side numeral of the code is 0, then the wire will be of a single color shown by the left-hand side numeral (see the above).

Note 1: If the right-hand side numeral is not 0, that particular wire has a spiral color code. The left-hand side character shows the base color and the right-hand side one, the spiral color.

<Example> 51.....WHITE/RED



Note 2: The character following the wire color code indicates the size of the wire.

U:	AWG16
K:	AWG18
L:	AWG20
None:	AWG22

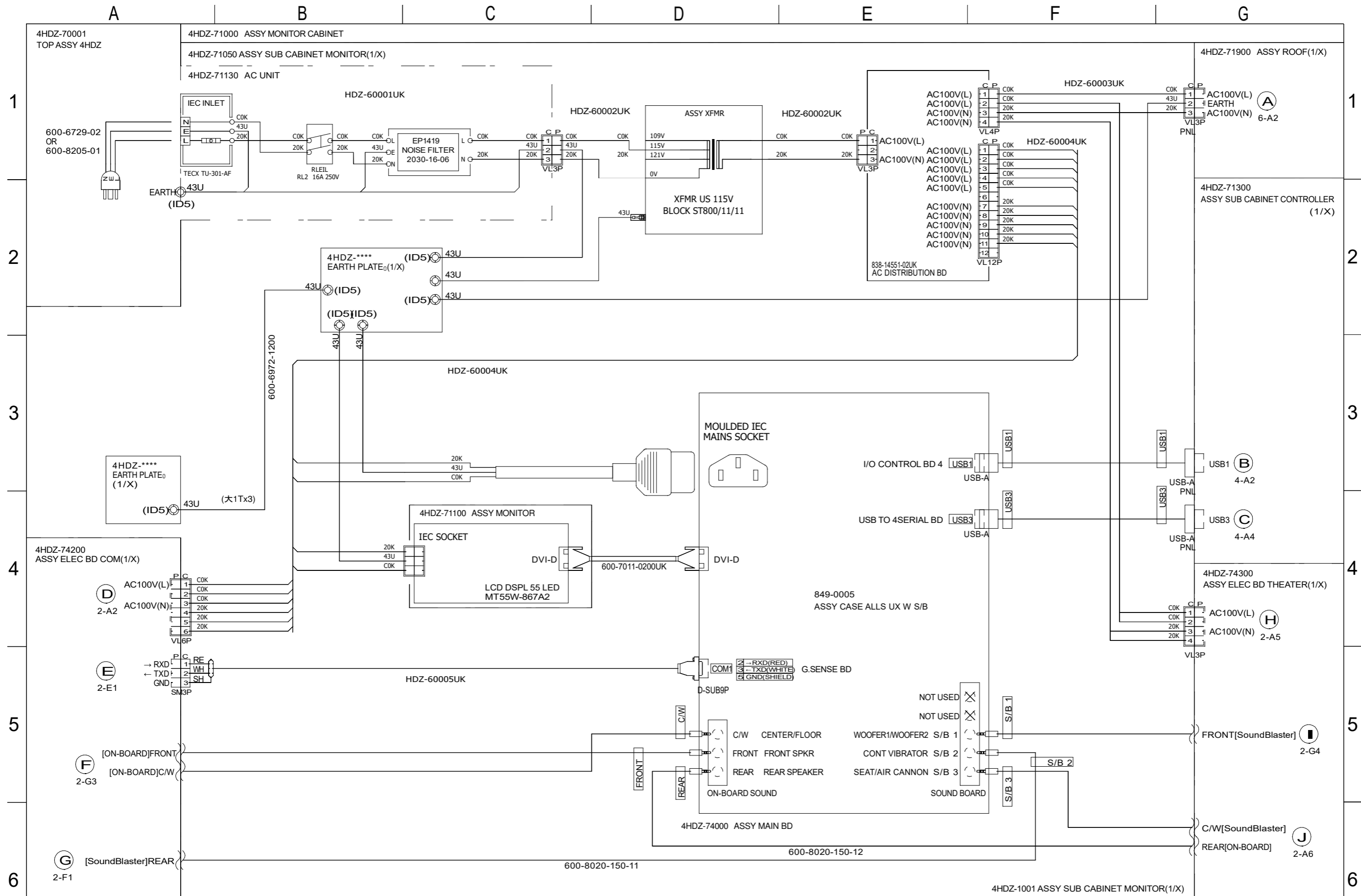

8	BLACK	E	LIGHT GREEN	43	EARTH WIRE
7	ORANGE	D	PURPLE	U	AWG16 UL1015
5	WHITE	C	BROWN	K	AWG18 UL1015
4	GREEN	B	SKY BLUE	L	AWG20 UL1007
3	YELLOW	A	PINK	T	AWG22 UL1007
2	BLUE				AWG24 UL1007
1	RED	9	GRAY		

設計	製圖	検閲	承認
RA			

SEGA THIS DRAWING WILL IN NO WAY BE COPIED. TO BE RETURNED ON DEMAND.

HOUSE OF THE DEAD SCARLET DAWN

DIAGRAM No. (1/7)

4HDZ-71050 ASSY SUB CABINET MONITOR(2/X)

1
2
3
4
5
6

1
2
3
4
5
6

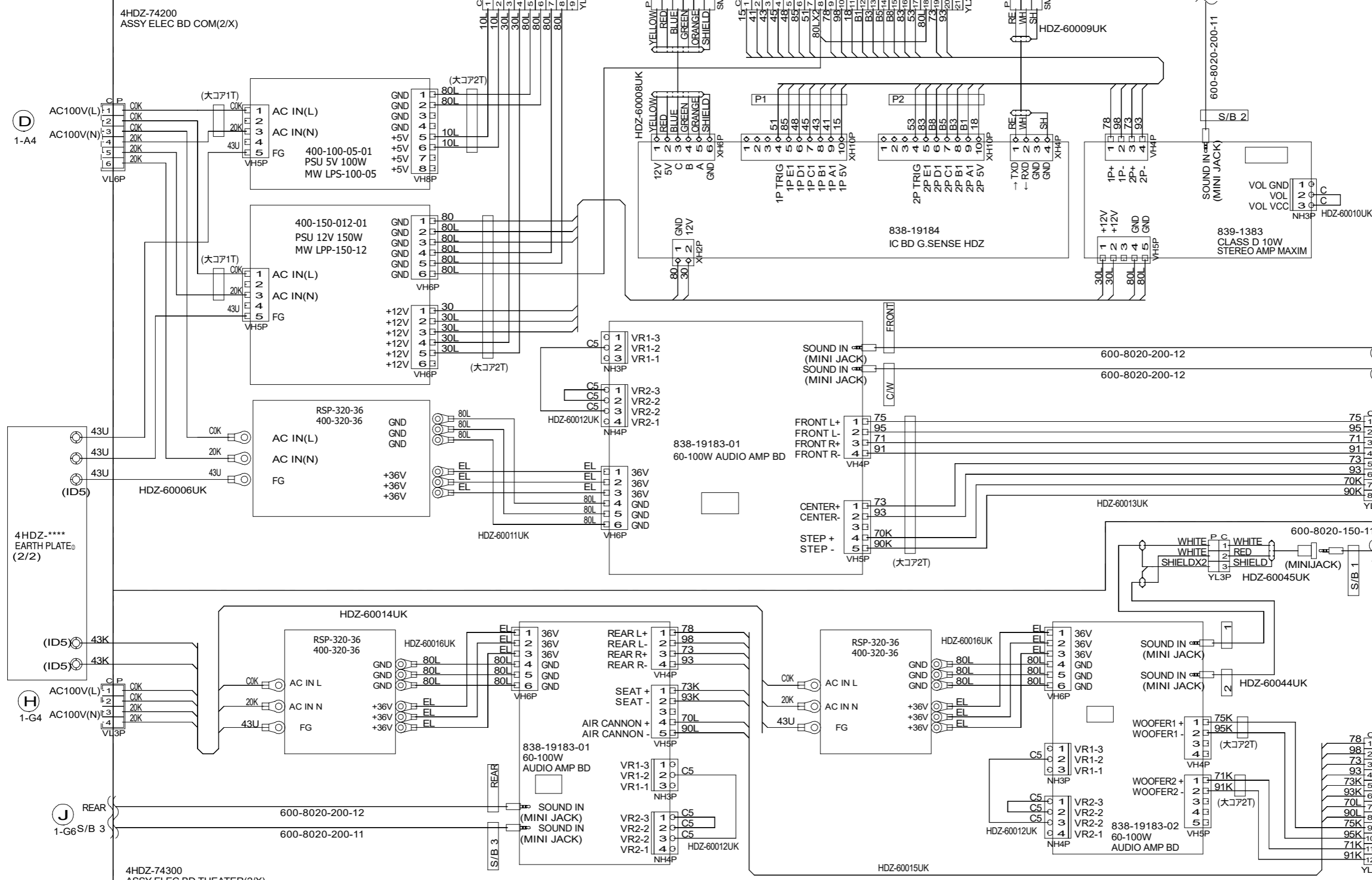

8	BLACK	E	LIGHT GREEN
7	ORANGE	D	PURPLE
5	WHITE	C	BROWN
4	GREEN	B	SKY BLUE
3	YELLOW	A	PINK
2	BLUE		
1	RED	9	GRAY

43	EARTH WIRE
U	AWG16 UL1015
K	AWG18 UL1015
L	AWG20 UL1007
AWG22	UL1007
T	AWG24 UL1007

設計	製図	検閲	承認
RA			

SEGA THIS DRAWING WILL IN NO WAY BE COPIED. TO BE RETURNED ON DEMAND.

HOUSE OF THE DEAD SCARLET DAWN

DIAGRAM No. (2/7)

ALTERATION TOP-ASSY DESCRIPTION

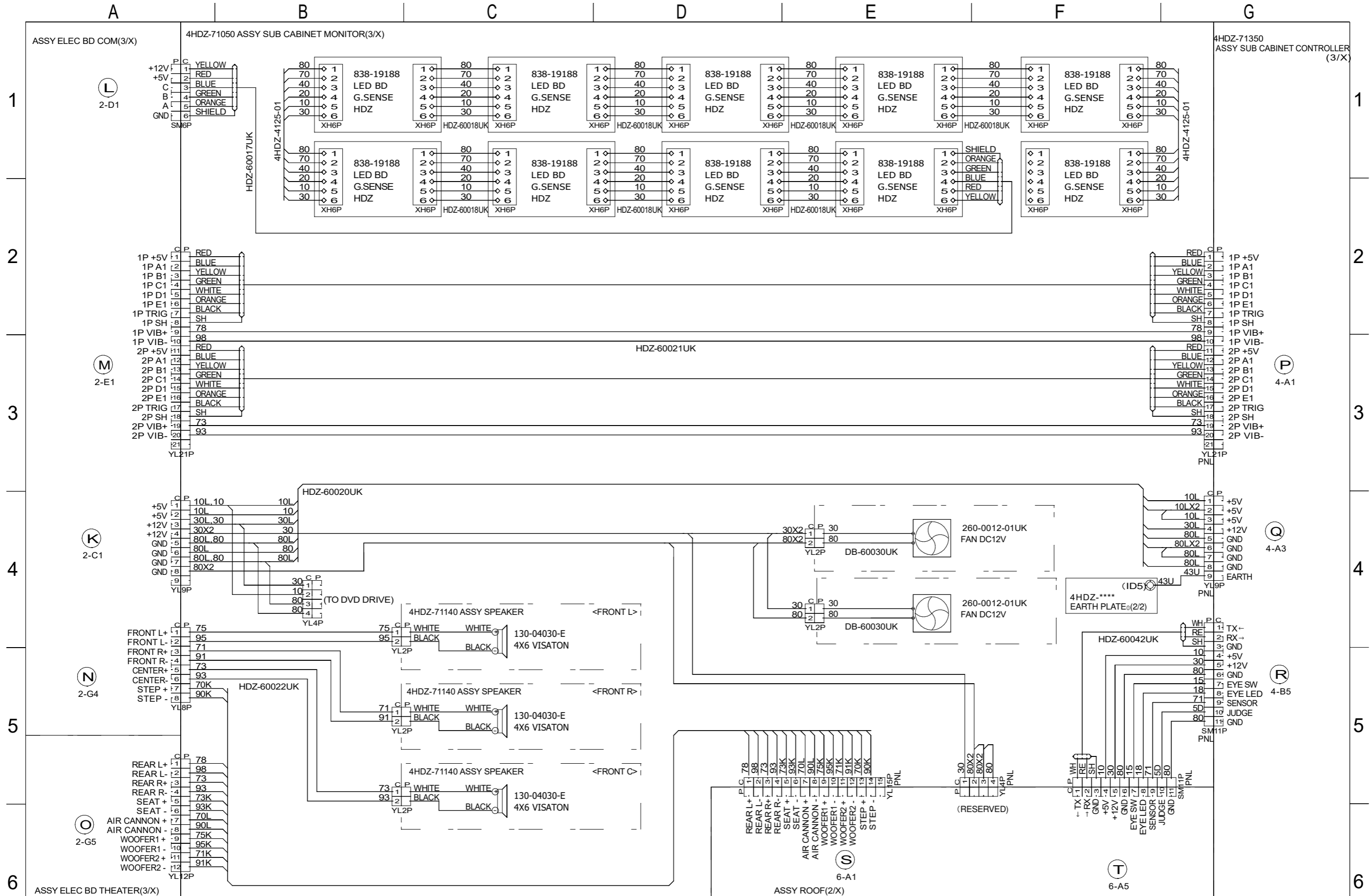

8	BLACK	E	LIGHT GREEN	43	EARTH WIRE
7	ORANGE	D	PURPLE	U	AWG18 UL1015
5	WHITE	C	BROWN	K	AWG18 UL1015
4	GREEN	B	SKY BLUE	L	AWG20 UL1007
3	YELLOW	A	PINK	L	AWG22 UL1007
2	BLUE	9	GRAY	T	AWG24 UL1007
1	RED				

ALTERATION	TOP-ASSY	RA	SEGA	THIS DRAWING WILL IN NO WAY BE COPIED. TO BE RETURNED ON DEMAND.
			HOUSE OF THE DEAD SCARLET DAWN	(3 / 7)
			DIAGRAM No.	

4HDZ-71350 ASSY SUB CABINET CONTROLLER(4/4)

1
2
3
4
5
6

1
2
3
4
5
6

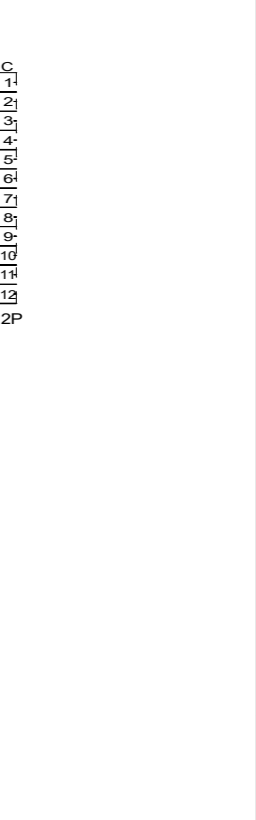
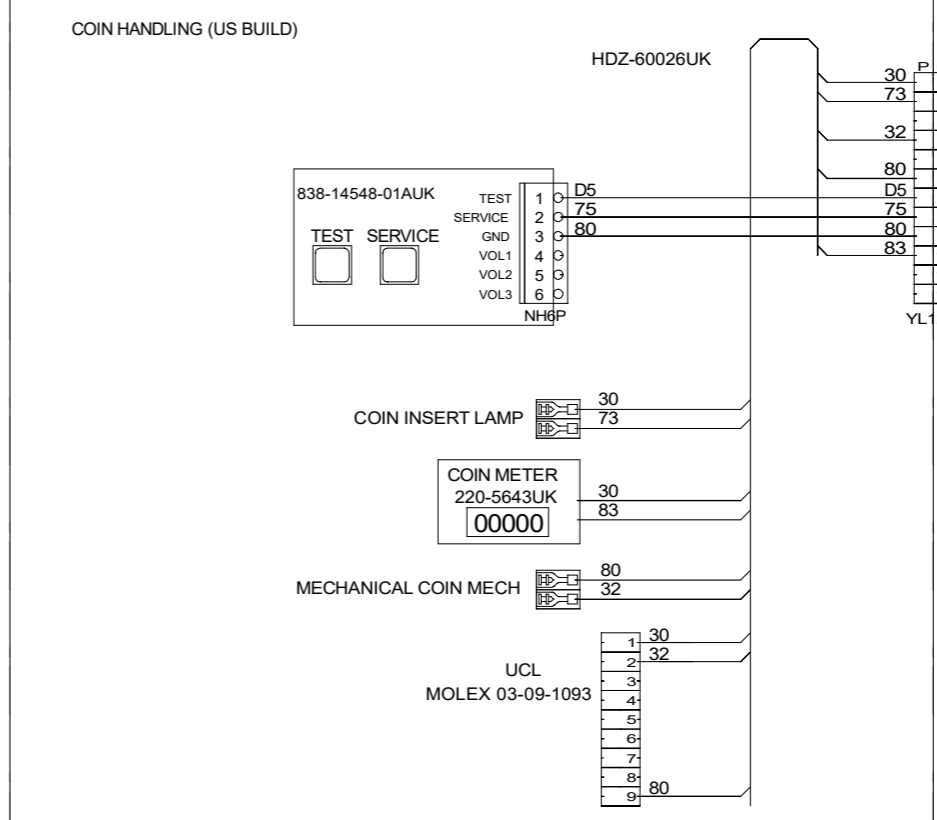
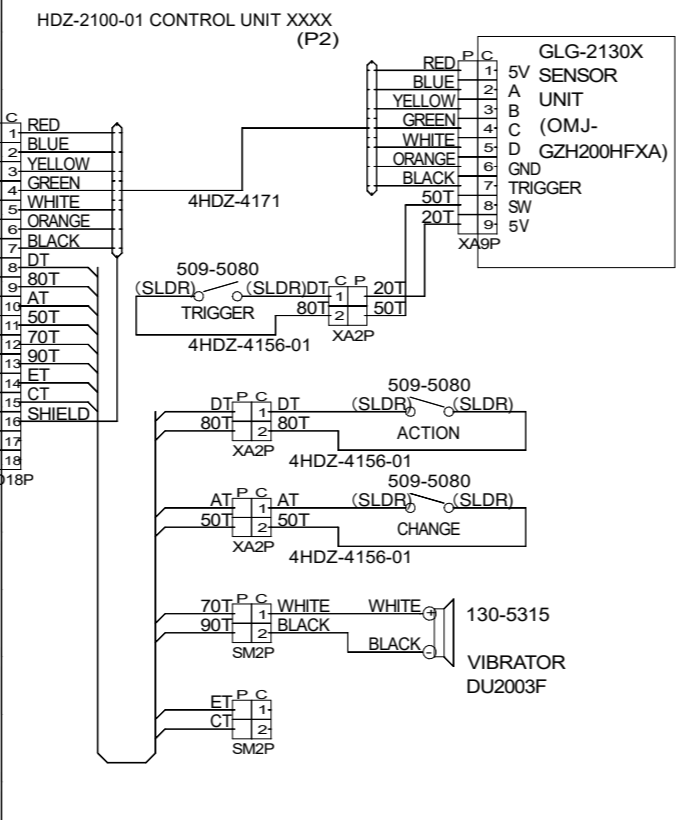
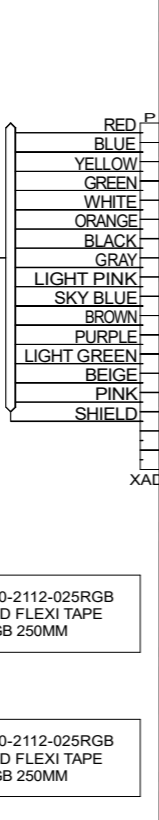
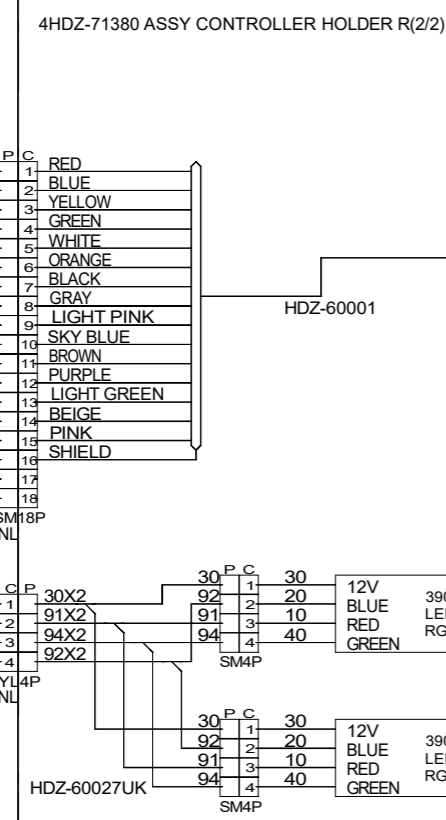
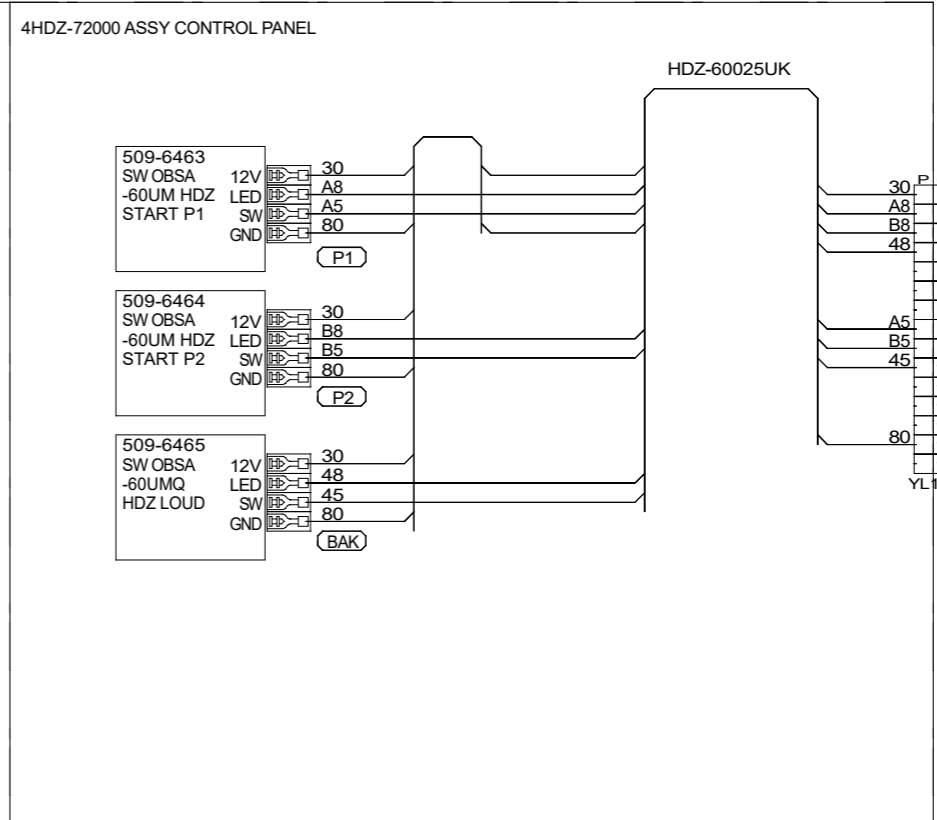
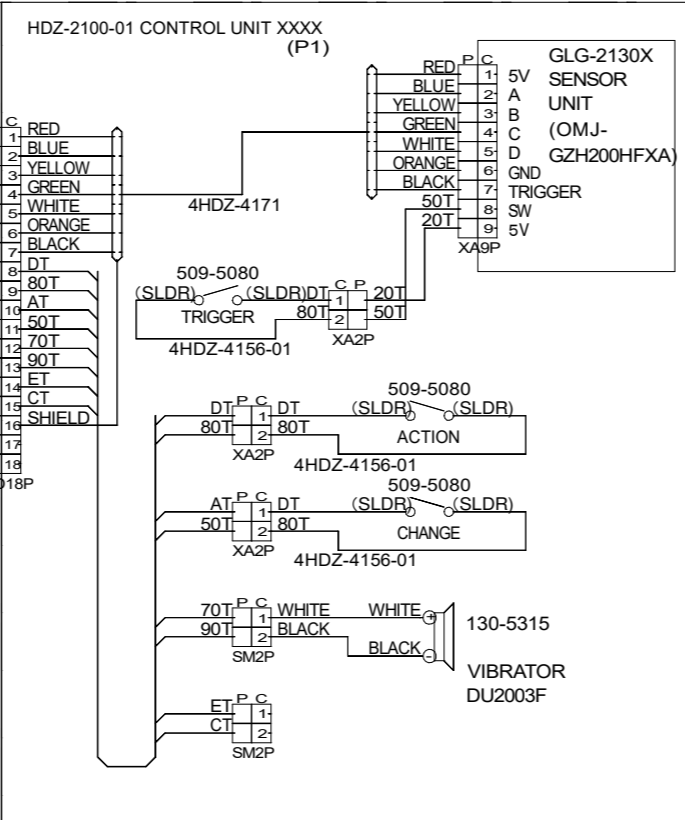
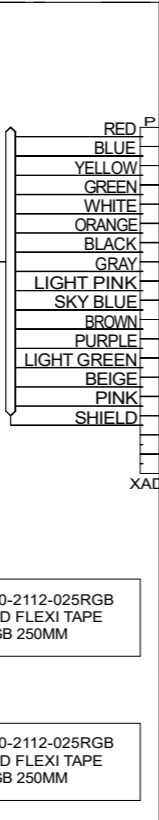
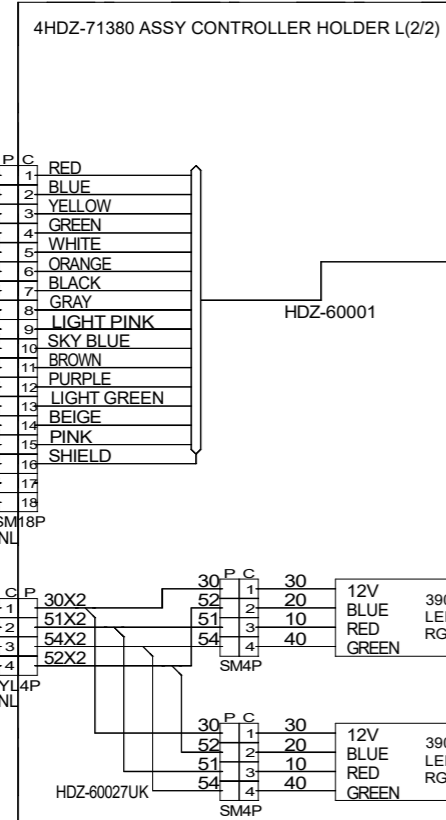

8	BLACK	E	LIGHT GREEN	43	EARTH WIRE	設計	製図	検印	承認	SEGA THIS DRAWING WILL IN NO WAY BE COPIED. TO BE RETURNED ON DEMAND.	HOUSE OF THE DEAD SCARLET DAWN	(5 / 7)
7	ORANGE	D	PURPLE	U	AWG16 UL1015	RA						
5	WHITE	C	BROWN	K	AWG18 UL1015							
4	GREEN	B	SKY BLUE	L	AWG20 UL1007							
3	YELLOW	A	PINK		AWG22 UL1007							
2	BLUE	9	GRAY	T	AWG24 UL1007							
1	RED											

ALTERATION A B C D E F G TOP-ASSY RA SEGA THIS DRAWING WILL IN NO WAY BE COPIED. TO BE RETURNED ON DEMAND. HOUSE OF THE DEAD SCARLET DAWN (5 / 7) DESCRIPTION DIAGRAM No.

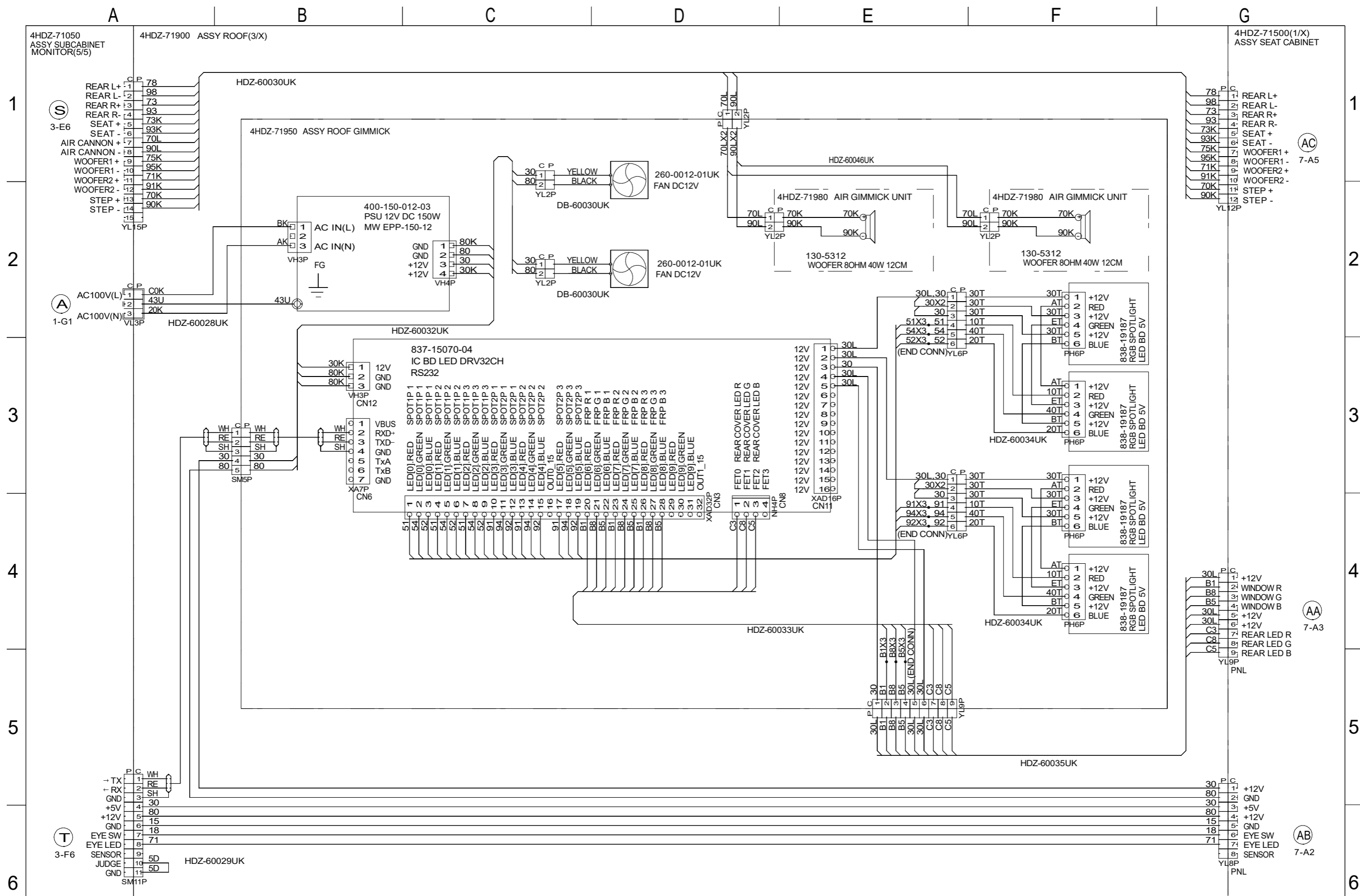

8	BLACK	E	LIGHT GREEN	43	EARTH WIRE
7	ORANGE	D	PURPLE	U	AWG16 UL1015
5	WHITE	C	BROWN	K	AWG18 UL1015
4	GREEN	B	SKY BLUE	L	AWG20 UL1007
3	YELLOW	A	PINK	AWG22 UL1007	
2	BLUE	9	GRAY	AWG24 UL1007	
1	RED				

設計	製圖	検閲	承認
RA			

SEGA THIS DRAWING WILL IN NO WAY BE COPIED. TO BE RETURNED ON DEMAND.
HOUSE OF THE DEAD SCARLET DAWN

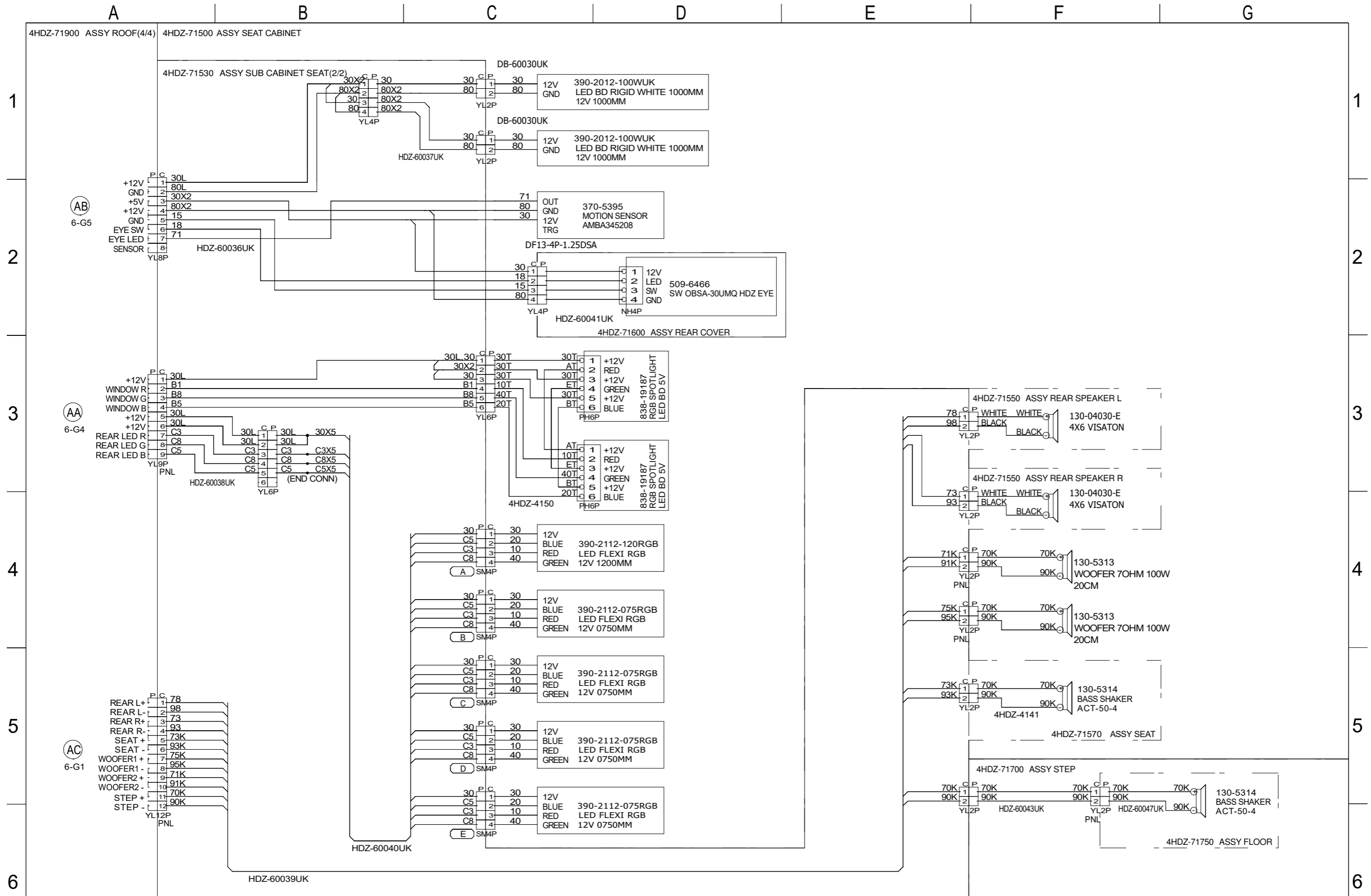

8	BLACK		43	EARTH WIRE
7	ORANGE	E	LIGHT GREEN	
5	WHITE	D	PURPLE	
4	GREEN	C	BROWN	
3	YELLOW	B	SKY BLUE	
2	BLUE	A	PINK	
1	RED	9	GRAY	

U	AWG16	UL1015
K	AWG18	UL1015
L	AWG20	UL1007
A	AWG22	UL1007
T	AWG24	UL1007

設計	製図	検図	承認	SEGA	THIS DRAWING WILL IN NO WAY BE COPIED. TO BE RETURNED ON DEMAND.
RA				HOUSE OF THE DEAD SCARLET DAWN	(7/7)
DESCRIPTION					DIAGRAM No.

- SEGA TOTAL SOLUTIONS -

42 Barwell Business Park
Leatherhead Road,
Chessington,
Surrey,
KT9 2NY
United Kingdom

Tel: +44 (0) 208 391 8060
Fax: +44 (0) 208 391 8096



Exclusive Suppliers of SEGA Spares

To Heathrow Airport

