

420-0030-00UK
1st PRINTING



Sega Amusements International Limited.
42 Barwell Business Park, Leatherhead Road, Chessington, Surrey, KT9 2NY. United Kingdom.
Telephone: +44 (0) 208 391 8090 Facsimile: +44 (0) 208 391 8099
email: mailbox@sega.co.uk Web: <http://www.segaarcade.com>

© SEGA

Errors & Omissions Excepted (E&OE)

"TRANSFORMERS" IS A
REGISTERED TRADEMARK
OF HASBRO, INC. ALL RIGHTS
RESERVED.

TRANSFORMERS: SHADOWS RISING

OWNER'S MANUAL

420-0030-00UK



TRANSFORMERS™ SHADOWS RISING

OWNER'S MANUAL



IMPORTANT

- Before using this product, read this manual carefully to understand the contents herein stated.
- After reading this manual, be sure to keep it near the product or in a convenient place for easy reference when necessary.

BEFORE USING THE PRODUCT, BE SURE TO READ THE FOLLOWING:

To maintain safety:

To ensure the safe operation of this product, be sure to read the following before usage: The following instructions are intended for the users, operators and the personnel in charge of the operation of the product. After carefully reading and sufficiently understanding the warning displays and cautions, handle the product appropriately. Be sure to keep this manual close to the product or in a convenient place for future reference.

Herein, explanations which require special attention are enclosed with dual lines. Depending on the potentially hazardous degrees, the terms of DANGER, WARNING, CAUTION, etc. are used. Be sure to understand the contents of the displays before reading the text.



Indicates that mishandling the product by disregarding this pictograph will cause severe injury or death.



Indicates that mishandling the product by disregarding this warning will cause a potentially hazardous situation which can result in death or serious injury.



Indicates that mishandling the product by disregarding this caution will cause a slight hazardous situation which can result in personal injury and/or material damage.

For the safe usage of the product, the following pictographs are used:



Indicates "HANDLE WITH CARE." In order to protect the human body and equipment, this display is attached to places where the instruction manual should be referred to.



Indicates a "protective earth terminal." Before operating the equipment, be sure to connect it to the ground (this step may be omitted for products in which a power cable with earth is used).

- **Perform work in accordance with the instructions herein stated.**
Instructions for work are explained by paying attention to the aspect of accident prevention. Failing to perform work as per the instructions can cause accidents. In the case where only those who have technical expertise should perform the work to avoid hazardous situation, the instructions herein state that the site maintenance personnel should perform such work.
- **Be sure to turn off the power before working on the machine.**
To prevent an electric shock, be sure to turn off the power and unplug the power cable before carrying out any work that requires direct contact with the interior of the product. If the work is to be performed in the power-on status, the instruction manual herein always states to that effect.
- **Be sure to ground the earth terminal (this is not required in the case where a power cable with earth is used).**
This product is equipped with the earth terminal. When installing the product, connect the earth terminal to the "accurately grounded indoor earth terminal" by using an earth wire. Unless the product is grounded appropriately, the user can be subject to an electric shock. After performing repair, etc. for the control equipment, ensure that the earth wire is firmly connected to the control equipment.
- **Ensure that the power supply used is equipped with an earth leakage breaker.**
Using a power supply which is not equipped with the earth leakage breaker can cause a fire when earth leakage occurs.
- **Be sure to use fuses which meet the specified rating (only for the machines which use fuses).**
Using fuses exceeding the specified rating can cause a fire and an electric shock.

- **Specification changes (removal of equipment, conversions and additions) not designated by SEGA are not allowed.**

The parts of the product include warning labels for safety, covers for personal protection, etc. It is very hazardous to operate the product by removing parts and/or modifying the circuits. Should doors, lids and protective parts be damaged or lost, refrain from operating the product, and contact where the product was purchased from or the office herein stated.

SEGA shall not be held responsible for any accidents or compensation for damage to a third party resulting from the specifications not designated by SEGA.

- **Ensure that the product meets the requirements of appropriate electrical specifications.**

Before installing the product, check for electrical specifications. SEGA products have a nameplate on which the electrical specifications are described. Ensure that the product is compatible with the power supply voltage and frequency requirements of the location. Using any electrical specifications different from the designated specifications can cause a fire and an electric shock.

- **Install and operate the product in places where appropriate lighting is available, allowing warning labels to be clearly read.**

To ensure safety for the customers, labels and printed instructions describing potentially hazardous situations are applied to places where accidents can be caused. Ensure that where the product is operated has sufficient lighting allowing the warnings to be read. If any label is peeled off, apply it again immediately. Please place an order with where the product was purchased from or the office herein stated.

- **When handling the monitor, be very careful (applies only to products with monitors).**

Some of the monitor parts are subject to high tension voltage. Even after turning off the power, some portions are still subject to high tension voltage. Monitor repair and replacement should be performed only by those technical personnel who have knowledge of electricity and technical expertise.

- **Be sure to adjust the monitor properly (applies only to products with monitors).**

Do not operate the product leaving on-screen flickering or blurring as it is. Using the product with the monitor not properly adjusted may cause dizziness or a headache to an operator, a player, or customer.

- **When transporting or reselling this product, be sure to attach this manual to the product.**

* *In the case where commercially available monitors and printers are used in this product, only the contents relating to this product are explained herein. Some commercially available equipment has functions and reactions not stated in this manual. Read this manual together with the specific instruction manual of such equipment.*

* *Descriptions herein contained may be subject to improvement changes without notice.*

* *The contents described herein are fully prepared with due care. However, should any question arise or errors be found, please contact SEGA.*

INSPECTIONS IMMEDIATELY AFTER TRANSPORTING THE PRODUCT TO THE LOCATION

Normally, at the time of shipment, SEGA products are in a status allowing for usage immediately after transporting to the location. Nevertheless, an irregular situation may occur during transportation. Before turning on the power, check the following points to ensure that the product has been transported in a satisfactory status:

- Are there any dented portions or defects (cuts, etc.) on the external surfaces of the cabinet?
- Are casters and adjusters damaged?
- Do the power supply voltage and frequency requirements meet with those of the location?
- Are all wiring connectors correctly and securely connected? Unless connected in the correct way, connector connections can not be made accurately. Do not insert connectors forcibly.
- Do power cables have cuts and dents?
- Are all accessories available?
- Can all doors and lids be opened with the accessory keys? Can doors and lids be firmly closed?

INTRODUCTION

This manual is intended to provide detailed descriptions together with all necessary information covering the general operation of electronic assemblies, electromechanical, servicing control, spare parts, etc. for the product: "TRANSFORMERS: SHADOWS RISING"

This manual is intended for the owners, personnel managers in charge of operation of this product. Operate the product after carefully reading and sufficiently understanding the instructions.

In the unlikely event that the product does not function correctly, DO NOT allow anyone other than a technician to touch the internal system. Turn off the power to the machine, making sure to unplug the electrical cord from the outlet, and contact the office listed below or the point-of-purchase for this product.

Use of this product is unlikely to cause physical injuries or damage to property. However, points that require special attention are indicated by bold text, the words "STOP, IMPORTANT or CAUTION" and the symbols below.



Indicates important information that, if ignored, may result in the mishandling of the product and cause faulty operation or damage to the product.



Indicates a warning or caution that, if ignored, may result in the mishandling of the product and cause faulty operation or damage to the product.

Sega Amusements Europe Limited.

42 Barwell Business Park, Leatherhead Road, Chessington, Surrey, KT9 2NY. United Kingdom.

European Sales:	+44 (0) 208 391 8090	Facsimile:	+44 (0) 208 391 8099
STS (Spares):	+44 (0) 208 391 8060	Facsimile:	+44 (0) 208 391 8096
USA Sales:	+00 (1) 224 265 4287		
email:	mailbox@sega.co.uk	Web:	http://www.segaarcade.com

PLAY IT! AMUSEMENTS, INC.

252 Beinoris Drive, Wood Dale, IL. 60191, USA

Part Sales:	+00 (1) 847-364-9787 ext 102
Tech Support:	+00 (1) 847-364-9787 ext 103/113

SPECIFICATIONS

Standard Cabinet	
Machine Dimensions:	1.74m (68.5in) [Width] x 2.12m (83.4in) [Depth]
Machine Height:	2.91m (114.7in) (Installed)
Machine Weight:	499kg Approx (Installed)
Power, maximum current:	-340w-
Rating:	1.7A @ 240vac 3.4A @ 120vac

Definition of 'Site Maintenance Personnel' or Other Qualified Individuals



Procedures not described in this manual or marked as 'to be carried out by site maintenance personnel or other qualified professionals' should not be carried out by personnel without the necessary skill or technological experience. Work carried out by unqualified persons may cause serious accidents, including electrocution.

Parts replacement, maintenance inspections and troubleshooting should be carried out by site maintenance personnel or other qualified professionals. This manual includes directions for potentially dangerous procedures which should only be carried out by professionals with the appropriate specialised knowledge.

The site maintenance personnel or other qualified professionals mentioned in this manual are defined as follows:

Site maintenance personnel:

Individuals with experience in maintaining amusement equipment, vending machines, etc., working under the supervision of the owner/operator of this product to maintain machines within amusement facilities or similar premises by carrying out everyday procedures such as assembly, maintenance inspections, and replacement of units/expendable parts.

Activities to be carried out by site maintenance personnel:

Amusement equipment/vending machine assembly, maintenance inspection and replacement of units/expendable parts.

Other qualified professionals:

Persons employed by amusement equipment manufacturers, or involved in design, production, testing or maintenance of amusement equipment. The individual should have either graduated from technical school or hold similar qualifications in electrical/electronics/mechanical engineering.

Activities to be carried out by other qualified professionals:

Amusement equipment/vending machine assembly, repair/adjustment of electrical/electronic/mechanical parts.

Waste of Electrical and Electronic Equipment (WEEE) Statement.

The WEEE (Waste of Electrical and Electronic Equipment) directive places an obligation on all EU based manufacturers and importers of Electrical and Electronic Equipment (EEE) to ensure waste equipment is disposed of in accordance with the directive at the end of their useful life.

The symbol shown below will be placed on all products manufactured from 13th August 2005, which indicates this product must NOT be disposed of with other normal waste. Upon purchasing any EEE from SEGA Amusements International Ltd. The user accepts responsibility to dispose of their waste equipment by arranging to return it to a designated UK collection point (AATF) or an Approved Exporter (AE) for the correct recycling of waste electrical and electronic equipment.

For more information on Approved Authorised Treatment Facilities (AATF) within the UK please consult the government website www.gov.uk

For users outside of the UK EEE should be disposed of in accordance with the local policy on the recycling of Waste Electrical and Electronic Equipment.

Battery Recycling Statement.

The EC Directive on Batteries and Accumulators (2006/66/EC) aims to minimise the impact of batteries on the environment and encourage the recovery of the materials they contain. To achieve increased collection and recycling of waste batteries, the Directive places 'producer responsibility' obligations on manufacturers and importers of portable, industrial and automotive batteries.

The symbol shown below will be on all equipment fitted with batteries from 26th September 2008 and indicates they must NOT be disposed of with other normal waste. Instead, it is the user's responsibility to dispose of used batteries by arranging to return them to a designated collection point for the correct recycling.

For more information about where you can send your waste batteries for recycling contact your local authority office.

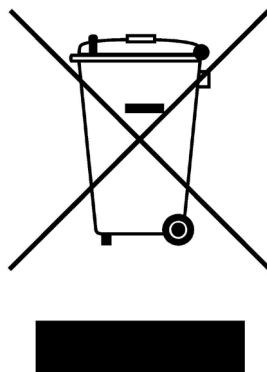

REGISTERED IN ENGLAND REGISTERED NO. 1711515

REGISTERED OFFICE: BLOCK C 42 BARWELL BUSINESS PARK, CHESSINGTON, SURREY KT9 2NY

LIST OF THIRD PARTY RIGHTS

LUA

Copyright (C) 1994-2008 Lua.org, PUC-Rio.

Permission is hereby granted, free of charge, to any person obtaining a copy of this software and associated documentation files (the “Software”), to deal in the Software without restriction, including without limitation the rights to use, copy, modify, merge, publish, distribute, sublicense, and/or sell copies of the Software, and to permit persons to whom the Software is furnished to do so, subject to the following conditions:

The above copyright notice and this permission notice shall be included in all copies or substantial portions of the Software.

THE SOFTWARE IS PROVIDED “AS IS”, WITHOUT WARRANTY OF ANY KIND, EXPRESS OR IMPLIED, INCLUDING BUT NOT LIMITED TO THE WARRANTIES OF MERCHANTABILITY, FITNESS FOR A PARTICULAR PURPOSE AND NONINFRINGEMENT. IN NO EVENT SHALL THE AUTHORS OR COPYRIGHT HOLDERS BE LIABLE FOR ANY CLAIM, DAMAGES OR OTHER LIABILITY, WHETHER IN AN ACTION OF CONTRACT, TORT OR OTHERWISE, ARISING FROM, OUT OF OR IN CONNECTION WITH THE SOFTWARE OR THE USE OR OTHER DEALINGS IN THE SOFTWARE.

TOLUA++

tolua++ is based on toLua (www.tecgraf.puc-rio.br/~celes/tolua), and it's licensed under the terms of the MIT license reproduced below. This means that Lua is free software and can be used for both academic and commercial purposes at absolutely no cost.

Copyright (C) 2009 Ariel Manzur.

Permission is hereby granted, free of charge, to any person obtaining a copy of this software and associated documentation files (the "Software"), to deal in the Software without restriction, including without limitation the rights to use, copy, modify, merge, publish, distribute, sublicense, and/or sell copies of the Software, and to permit persons to whom the Software is furnished to do so, subject to the following conditions:

The above copyright notice and this permission notice shall be included in all copies or substantial portions of the Software.

THE SOFTWARE IS PROVIDED "AS IS", WITHOUT WARRANTY OF ANY KIND, EXPRESS OR IMPLIED, INCLUDING BUT NOT LIMITED TO THE WARRANTIES OF MERCHANTABILITY, FITNESS FOR A PARTICULAR PURPOSE AND NONINFRINGEMENT. IN NO EVENT SHALL THE AUTHORS OR COPYRIGHT HOLDERS BE LIABLE FOR ANY CLAIM, DAMAGES OR OTHER LIABILITY, WHETHER IN AN ACTION OF CONTRACT, TORT OR OTHERWISE, ARISING FROM, OUT OF OR IN CONNECTION WITH THE SOFTWARE OR THE USE OR OTHER DEALINGS IN THE SOFTWARE.

JSON CPP

The JsonCpp library's source code, including accompanying documentation, tests and demonstration applications, are licensed under the following conditions...

Baptiste Lepilleur and The JsonCpp Authors explicitly disclaim copyright in all jurisdictions which recognize such a disclaimer. In such jurisdictions, this software is released into the Public Domain.

In jurisdictions which do not recognize Public Domain property (e.g. Germany as of 2010), this software is Copyright (c) 2007-2010 by Baptiste Lepilleur and The JsonCpp Authors, and is released under the terms of the MIT License (see below).

In jurisdictions which recognize Public Domain property, the user of this software may choose to accept it either as 1) Public Domain, 2) under the conditions of the MIT License (see below), or 3) under the terms of dual Public Domain/MIT License conditions described here, as they choose.

The MIT License is about as close to Public Domain as a license can get, and is described in clear, concise terms at:

http://en.wikipedia.org/wiki/MIT_License

The full text of the MIT License follows:

Copyright (c) 2007-2010 Baptiste Lepilleur and The JsonCpp Authors

Permission is hereby granted, free of charge, to any person obtaining a copy of this software and associated documentation files (the "Software"), to deal in the Software without restriction, including without limitation the rights to use, copy, modify, merge, publish, distribute, sublicense, and/or sell copies of the Software, and to permit persons to whom the Software is furnished to do so, subject to the following conditions:

The above copyright notice and this permission notice shall be included in all copies or substantial portions of the Software.

THE SOFTWARE IS PROVIDED "AS IS", WITHOUT WARRANTY OF ANY KIND, EXPRESS OR IMPLIED, INCLUDING BUT NOT LIMITED TO THE WARRANTIES OF MERCHANTABILITY, FITNESS FOR A PARTICULAR PURPOSE AND NONINFRINGEMENT. IN NO EVENT SHALL THE AUTHORS OR COPYRIGHT HOLDERS BE LIABLE FOR ANY CLAIM, DAMAGES OR OTHER LIABILITY, WHETHER IN AN ACTION OF CONTRACT, TORT OR OTHERWISE, ARISING FROM, OUT OF OR IN CONNECTION WITH THE SOFTWARE OR THE USE OR OTHER DEALINGS IN THE SOFTWARE.

(END LICENSE TEXT)

The MIT license is compatible with both the GPL and commercial software, affording one all of the rights of Public Domain with the minor nuisance of being required to keep the above copyright notice and license text in the source code. Note also that by accepting the Public Domain "license" you can re-license your copy using whatever license you like.

ZLIB

zlib.h -- interface of the 'zlib' general purpose compression library
version 1.2.3, July 18th, 2005

Copyright (C) 1995-2005 Jean-loup Gailly and Mark Adler

This software is provided 'as-is', without any express or implied warranty. In no event will the authors be held liable for any damages arising from the use of this software.

Permission is granted to anyone to use this software for any purpose, including commercial applications, and to alter it and redistribute it freely, subject to the following restrictions:

1. The origin of this software must not be misrepresented; you must not claim that you wrote the original software. If you use this software in a product, an acknowledgment in the product documentation would be appreciated but is not required.
2. Altered source versions must be plainly marked as such, and must not be misrepresented as being the original software.
3. This notice may not be removed or altered from any source distribution.

Jean-loup Gailly Mark Adler
jloup@gzip.org madler@alumni.caltech.edu

The data format used by the zlib library is described by RFCs (Request for Comments) 1950 to 1952 in the files <http://www.ietf.org/rfc/rfc1950.txt> (zlib format), [rfc1951.txt](http://www.ietf.org/rfc/rfc1951.txt) (deflate format) and [rfc1952.txt](http://www.ietf.org/rfc/rfc1952.txt) (gzip format)..

SMAA

Copyright (C) 2011 Jorge Jimenez (jorge@iryoku.com)

Copyright (C) 2011 Jose I. Echevarria (joseignacioechevarria@gmail.com)

Copyright (C) 2011 Belen Masia (bmasia@unizar.es)

Copyright (C) 2011 Fernando Navarro (fernandn@microsoft.com)

Copyright (C) 2011 Diego Gutierrez (diegog@unizar.es)

All rights reserved.

Redistribution and use in source and binary forms, with or without modification, are permitted provided that the following conditions are met:

1. Redistributions of source code must retain the above copyright notice, this list of conditions and the following disclaimer.
2. Redistributions in binary form must reproduce the following disclaimer in the documentation and/or other materials provided with the distribution:

“Uses SMAA. Copyright (C) 2011 by Jorge Jimenez, Jose I. Echevarria, Tiago Sousa, Belen Masia, Fernando Navarro and Diego Gutierrez.”

THIS SOFTWARE IS PROVIDED BY THE COPYRIGHT HOLDERS AND CONTRIBUTORS “AS IS” AND ANY EXPRESS OR IMPLIED WARRANTIES, INCLUDING, BUT NOT LIMITED TO, THE IMPLIED WARRANTIES OF MERCHANTABILITY AND FITNESS FOR A PARTICULAR PURPOSE ARE DISCLAIMED. IN NO EVENT SHALL COPYRIGHT HOLDERS OR CONTRIBUTORS BE LIABLE FOR ANY DIRECT, INDIRECT, INCIDENTAL, SPECIAL, EXEMPLARY, OR CONSEQUENTIAL DAMAGES (INCLUDING, BUT NOT LIMITED TO, PROCUREMENT OF SUBSTITUTE GOODS OR SERVICES; LOSS OF USE, DATA, OR PROFITS; OR BUSINESS INTERRUPTION) HOWEVER CAUSED AND ON ANY THEORY OF LIABILITY, WHETHER IN CONTRACT, STRICT LIABILITY, OR TORT (INCLUDING NEGLIGENCE OR OTHERWISE) ARISING IN ANY WAY OUT OF THE USE OF THIS SOFTWARE, EVEN IF ADVISED OF THE POSSIBILITY OF SUCH DAMAGE.

The views and conclusions contained in the software and documentation are those of the authors and should not be interpreted as representing official policies, either expressed or implied, of the copyright holders.

TABLE OF CONTENTS

	INTRODUCTION	iii
1	HANDLING PRECAUTIONS	1
2	PRECAUTIONS REGARDING INSTALLATION LOCATION	5
	2-1 LIMITATIONS OF USAGE	6
	2-2 OPERATION AREA	7
3	PRECAUTIONS REGARDING PRODUCT OPERATION	8
	3-1 BEFORE OPERATION	8
	3-2 DURING OPERATION (PAYING ATTENTION TO CUSTOMERS)	10
4	PARTS DESCRIPTION	12
5	ACCESSORIES	13
6	ASSEMBLY AND INSTALLATION	15
	6-1 UNPACKING THE CABINET	18
	6-2 ATTACHING THE EXHAUST PIPES	21
	6-3 ATTACHING THE SEAT	23
	6-4 JOINING THE CABINETS	24
	6-5 SECURING THE FLOOR PANELS	26
	6-6 SECURING THE GUN CABINET	28
	6-7 ATTACHING THE ROOF	29
	6-8 ATTACHING THE BILLBOARD (OPTIMUS HEAD)	30
	6-9 ATTACHING THE SHOULDER PANELS	32
	6-10 ATTACHING TOP BOX	33
	6-11 ATTACHING POP PANEL	35
	6-12 REMOVING TRANSIT BRACKET	36
	6-13 FIXATION TO SITE	37
	6-14 APPLYING "HOW TO PLAY" INSTRUCTIONS	39
	6-15 CONNECTING THE DVD DRIVE	40
	6-16 CONNECTION OF POWER AND GROUND CABLES	42
	6-17 ENGAGING POWER SUPPLY (SOFTWARE INSTALLATION)	45
	6-18 CONFIRMATION OF INSTALLATION	48
7	PRECAUTIONS WHEN MOVING	50
	7-1 MOVING THE MACHINE	50
	7-2 SEPARATING THE MONITOR/SEAT CABINET	52
8	GAME DESCRIPTION	57
9	EXPLANATION OF TEST AND DATA DISPLAY	69
	9-1 SWITCH UNIT AND COIN METER.	70
	9-2 SYSTEM TEST MODE	71
	9-3 SYSTEM INFORMATION	73

	9-4 INPUT TEST	74
	9-5 OUTPUT TEST	75
	9-6 DEVICE CALIBRATION	76
	9-7 COIN SETTINGS	77
	9-8 SCREEN TEST	78
	9-9 BOOKKEEPING	79
	9-10 CLOCK SETTINGS	81
	9-11 GAME ASSIGNMENTS	82
10	VIDEO DISPLAY	85
	10-1 GENERAL DESCRIPTION	85
	10-2 CLEANING THE SCREEN	86
11	CONTROL UNIT	87
	11-1 HOW TO REMOVE CONTROL UNIT	88
	11-2 ADJUSTING OR REPLACING THE X AXIS VOLUME	90
	11-3 ADJUSTING OR CHANGING THE Y AXIS VOLUME	95
	11-4 REPLACING THE TRIGGER SWITCH	99
	11-5 REPLACING THE FEEDBACK COIL	102
12	COIN HANDLING	104
	12-1 CLEANING THE COIN SELECTOR	104
	12-2 FAULT FINDING	107
	12-3 ADJUSTING THE PRICE OF PLAY (EXCEL)	108
	12-4 ADJUSTING THE PRICE OF PLAY (VTS)	109
13	REPLACING LAMPS AND LIGHTING	110
	13-1 COIN DOOR LAMP	110
	13-2 START BUTTON LAMP	111
14	PERIODIC INSPECTION	113
15	TROUBLESHOOTING	115
16	GAME BOARD	117
	16-1 HOW TO REMOVE GAME BOARD	118
	16-2 COMPOSITION OF THE GAME BOARD	119
17	DESIGN RELATED PARTS	120
18	PARTS LIST	121
19	WIRE COLOUR CODE TABLE	152
20	SCHEMATIC DIAGRAMS	153

1 HANDLING PRECAUTIONS

When installing or inspecting the machine, be very careful of the following points and pay attention to ensure that the player can enjoy the game safely.

Non-compliance with the following points or inappropriate handling running counter to the cautionary matters herein stated can cause personal injury or damage to the machine.

WARNING

- Before performing work, be sure to turn the power off. Performing the work without turning the power off can cause an electric shock or short circuit. In the case where work should be performed in the status of power on, this manual always states to that effect.
- To avoid an electric shock or short circuit, do not plug in or unplug quickly.
- To avoid an electric shock, do not plug in or unplug with a wet hand.
- Do not expose power cords or earth wires on the surface (floor, passage, etc.). If exposed, the power cords and earth wires are susceptible to damage. Damaged cords and wires can cause an electric shock or short circuit.
- To avoid causing a fire or an electric shock, do not put things on or damage the power cords.
- When or after installing the product, do not unnecessarily pull the power cord. If damaged, the power cord can cause a fire or an electric shock.
- In case the power cord is damaged, ask for a replacement through where the product was purchased from or the office herein stated. Using the cord as is damaged can cause fire, an electric shock or leakage.
- Be sure to perform grounding appropriately. Inappropriate grounding can cause an electric shock.
- Be sure to use fuses meeting the specified rating. Using fuses exceeding the specified rating can cause a fire or an electric shock.
- Be sure that connections such as IC BD are made properly. Insufficient insertion can cause an electric shock.
- Specification changes, removal of equipment, conversion and/or addition not designated by SEGA are not permitted.
 - Failure to observe this may cause a fire or an electric shock. Non-compliance with this instruction can have a bad influence upon physical conditions of the players or the onlookers, or result in injury during play.
 - SEGA shall not be held responsible for damage, compensation for damage to a third party, caused by specification changes not designated by SEGA.
- Do not perform any work or change parts not listed in this manual. Doing so may lead to an accident. If you need to perform any work not listed in this manual, request work from the office indicated in this manual or the point of purchase, or inquires for details.
- Be sure to perform periodic maintenance inspections herein stated.

STOP IMPORTANT

- For the IC board circuit inspections, only the logic tester is allowed. The use of a multiple-purpose tester is not permitted. Be sure to take due care in this regard.
- An LED Video Screen is employed for this machine. This screen is susceptible to damage, therefore, be very careful when cleaning the screen. For details, refer to the section "Monitor."
- Static electricity from your body may damage some electronics devices on the IC board. Before handling the IC board, touch a grounded metallic surface so that the static electricity can be discharged.
- Some parts are not designed and manufactured specifically for this game machine. The manufacturers may discontinue or change the specifications of such general-purpose parts. If this is the case, SEGA cannot repair or replace a failed game machine whether or not a warranty period has expired.

CONCERNING THE STICKER DISPLAY

This SEGA product has stickers attached describing the product manufacture No. (Serial No.) and Electrical Specifications. It also has a Sticker describing where to contact for repair and for purchasing parts.

When inquiring about or asking for repairs, mention the Serial No. and Name of Machine indicated on the Sticker. The Serial Number indicates the product register. Identical machines could have different parts depending on the date of production. Also, improvements and modifications might have been made after the publication of this manual. In order to ensure you order the correct parts, mention the Serial No. when contacting the applicable places.

CONCERNING WARNING DISPLAYS

This SEGA product has warning displays on stickers, labels and/or printed instructions adhered/attached to or incorporated in the places where a potentially hazardous situation could arise. The warning displays are intended for accident prevention for customers and for avoiding hazardous situations relating to maintenance and servicing work. Some portions of the cabinet contain high voltage and may cause accidents if touched. When performing maintenance, be very careful of the warning displays. It is especially important that any complex repair and replacement work not mentioned herein should be performed by those technical personnel who have knowledge of electricity and technical expertise.

In order to prevent accidents, caution any customer ignoring the warnings to cease and desist immediately.

1 HANDLING PRECAUTIONS

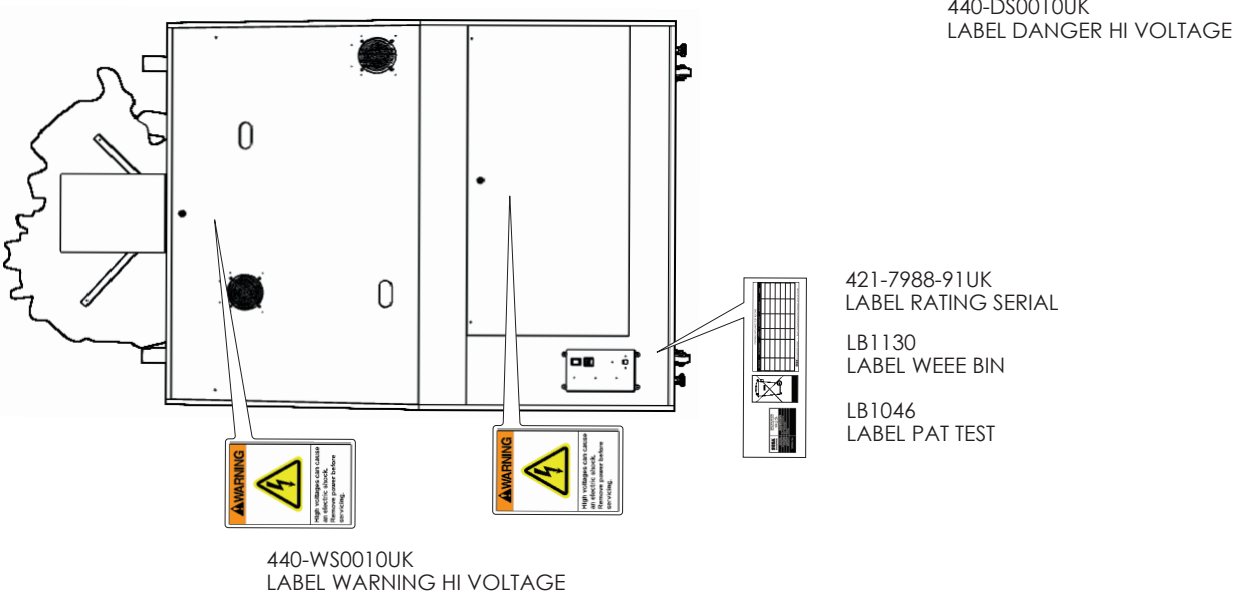
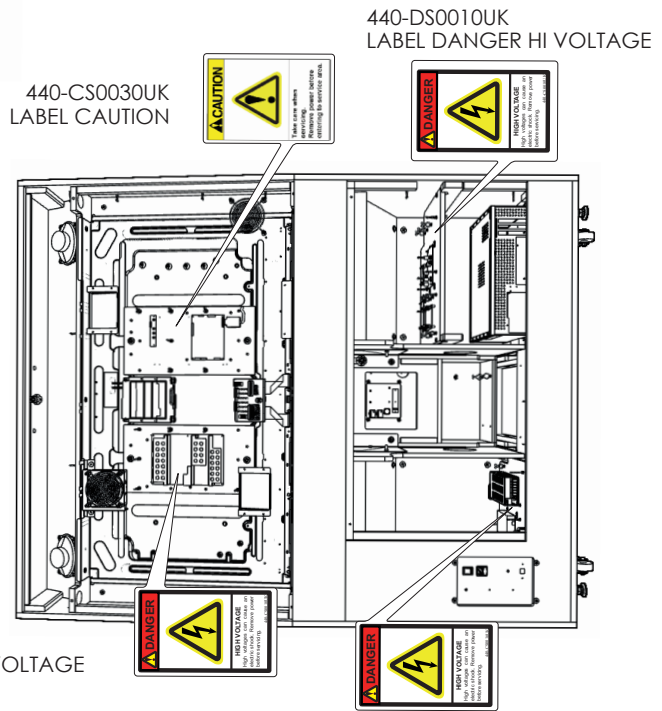
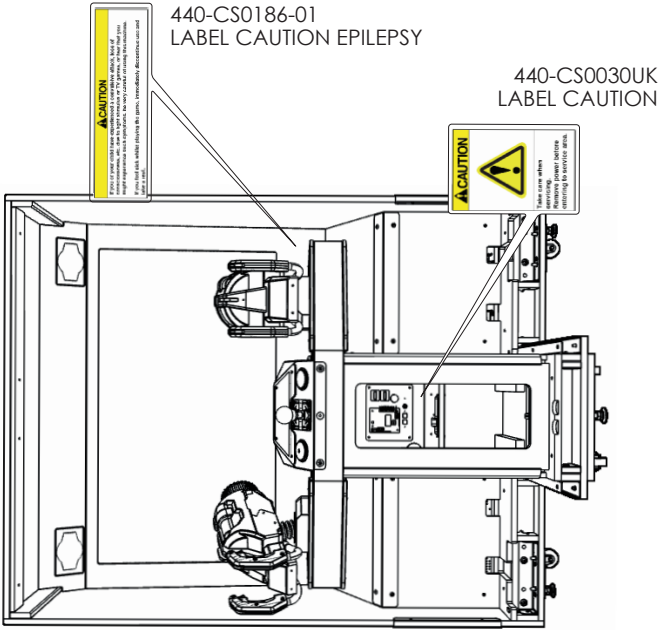

2 PRECAUTIONS REGARDING INSTALLATION LOCATION

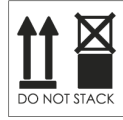

440-PL100UK
LABEL PACKING

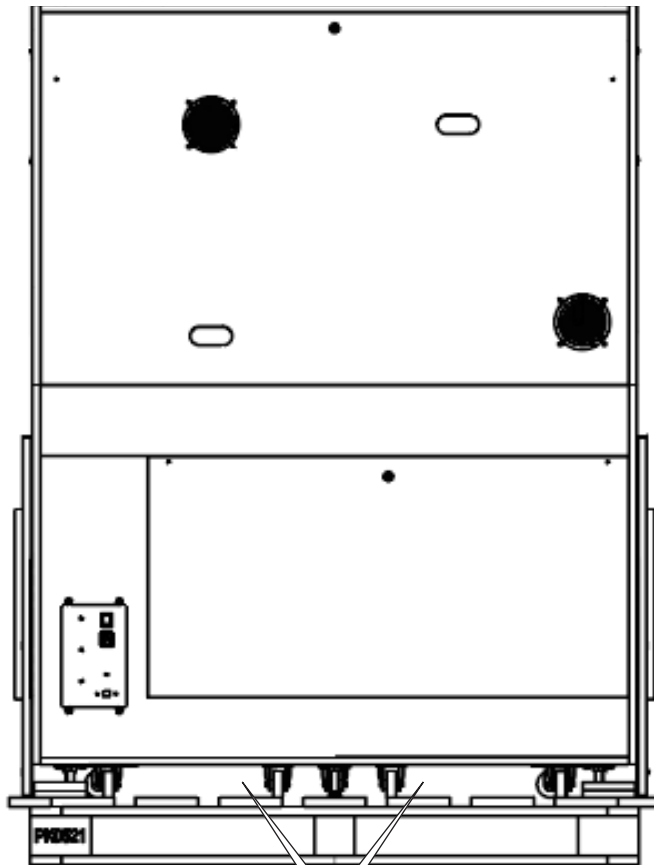
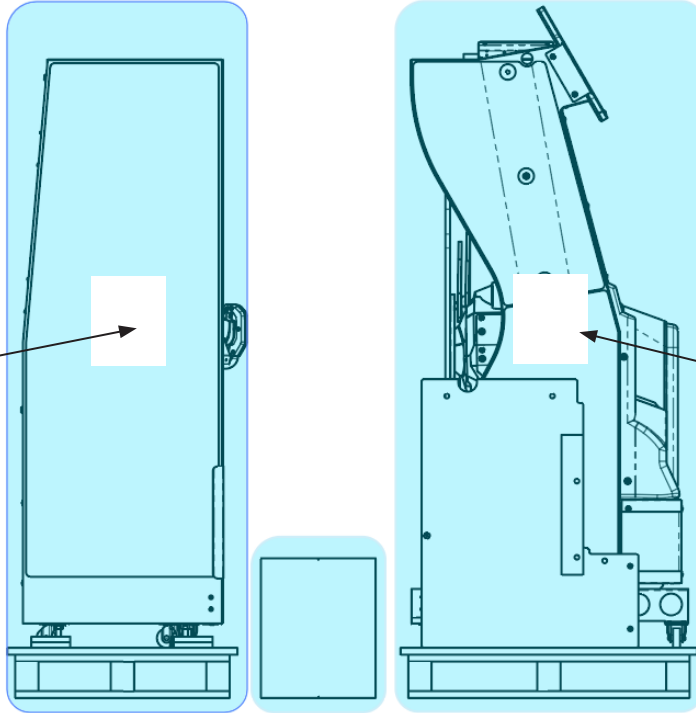

440-WS100UK
LABEL FORK HERE

2 PRECAUTIONS REGARDING INSTALLATION LOCATION

WARNING

This product is an indoor game machine. Do not install it outside. Even indoors, avoid installing in places mentioned below so as not to cause a fire, electric shock, injury and/or malfunction:

- Places subject to rain or water leakage, or places subject to high humidity in the proximity of an indoor swimming pool and/or shower, etc.
- Places subject to direct sunlight, or places subject to high temperatures in the proximity of heating units, etc.
- Places filled with inflammable gas or vicinity of highly inflammable/volatile chemicals or hazardous matter.
- Dusty places.
- Sloped surfaces.
- Places subject to any type of violent impact.
- Vicinity of anti-disaster facilities such as fire exits and fire extinguishers.
- The operating (ambient) temperature range is not from 5°C to 30°C.
- Places near water or spray from water such as a Jet Wash or Swimming Pool.

2-1 LIMITATIONS OF USAGE

WARNING

- Be sure to check the Electrical Specifications. Ensure that this product is compatible with the location's power supply, voltage, and frequency requirements. A plate describing Electrical Specifications is attached to the product. Non-compliance with the Electrical Specifications can cause a fire and electric shock.
- This product requires a breaker and earth mechanism as part of the location facilities. Using the product without these can cause a fire and electric shock.
- Ensure that the indoor wiring for the power supply is rated at 15 A or higher (AC single phase 100 V ~ 120 V area), and 7 A or higher (AC 220 V ~ 240 V area). Non-compliance with the Electrical Specifications can cause a fire and electric shock.
- Be sure to use an independent power supply equipped with an earth leakage breaker. Using a power supply without an earth leakage breaker can cause an outbreak of fire if a power surge occurs.
- Putting many loads on one electrical outlet can cause generation of heat and a fire resulting from overload.
- When using an extension cord, ensure that the cord is rated at 15 A or higher (AC 100 V ~ 120 V area) and 7 A or higher (AC 220 V ~ 240 V area). Using a cord rated lower than the specified rating can cause a fire and electric shock.

Electricity Consumption:

MAX. 340w @ 230VAC-240VAC

2-2 OPERATION AREA

WARNING

- For the operation of this machine, secure a minimum area of 3.1 m (W) x 3.67 m (D). If the machine rolls during play it could lead to serious injury, especially if anyone is hit on the head. You must secure the space specified in this document.
- Be sure to provide sufficient space specified in this manual. Do not allow objects to block the ventilation ports. It can cause generation of heat and a fire.
- SEGA shall not be held responsible for damage or compensation for damage to a third party, resulting from the failure to observe this instruction.
- If the machine does not fit through the entryway to the installation location, do not disassemble it without first consulting the instructions. If the machine still does not fit through the entryway after following the procedures in this manual, contact your retailer or the office listed in this manual.

IMPORTANT

To install this product, the entrance must be at least 1.75 m in width and 1.94 m in height.

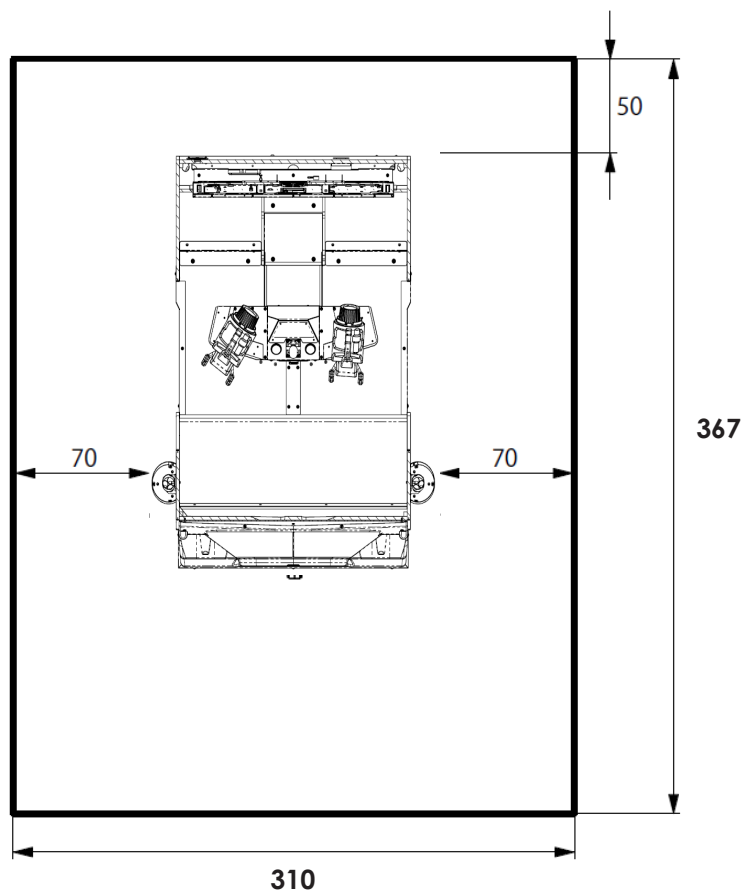

FIG. 2 Installation and operation area (cm)

3 PRECAUTIONS REGARDING PRODUCT OPERATION

To avoid injury and trouble, be sure to pay attention to the behavior of visitors and players.

3-1 BEFORE OPERATION

WARNING

In order to avoid accidents, check the following before starting the operation:

- To ensure maximum safety for the players and the customers, ensure that where the product is operated has sufficient lighting to allow any warnings to be read. Operation under insufficient lighting can cause bodily contact with each other, hitting accident, and/or trouble between customers.
- Be sure to perform appropriate adjustment of the monitor. For operation of this machine, do not leave monitor's flickering or deviation as is. Failure to observe this can have a bad influence upon the players' or the customers' physical conditions.
- It is suggested to ensure a space allowing the players who feel sick while playing the game to take a rest.
- Check if all of the adjusters are in contact with the surface. If they are not, the Cabinet can move and cause an accident.

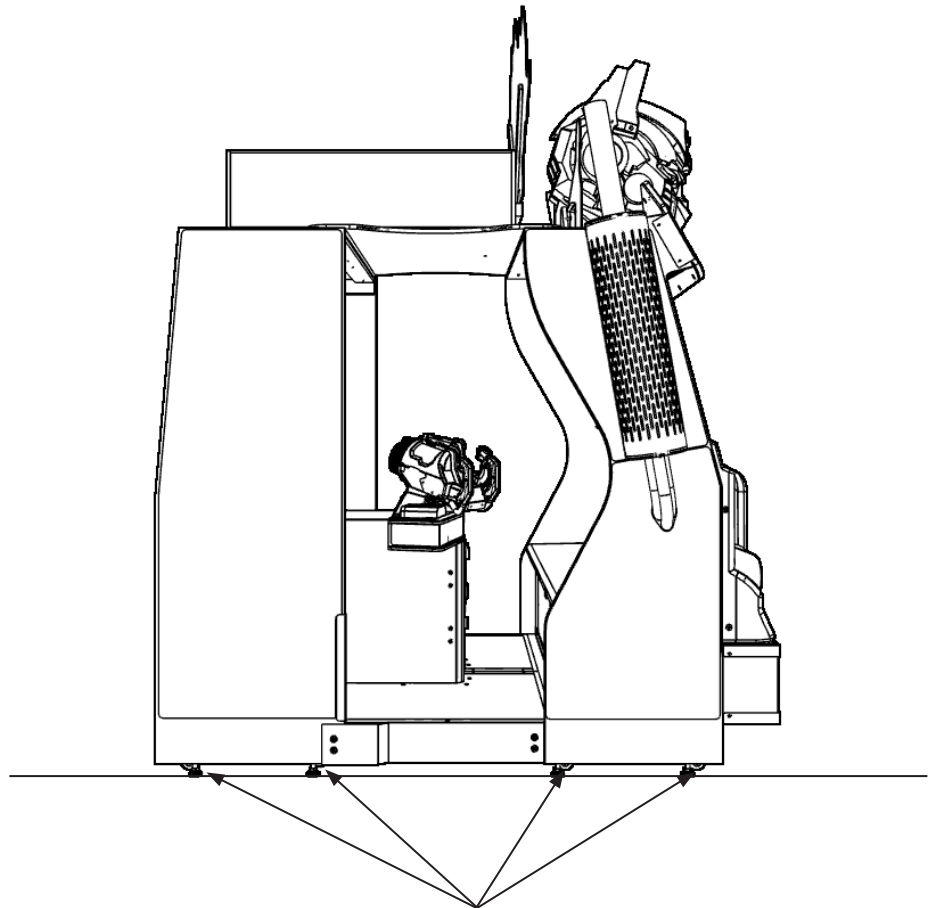

Ensure that all of the adjusters are in contact with the floor.

⚠ WARNING

- Do not put any heavy item on this product. Placing any heavy item on the product can cause a falling down accident or parts damage.
- Do not climb on the product. Climbing on the product can cause falling down accidents. To check the top portion of the product, use a step ladder.
- When using a stepladder or stool while working, do not hold onto the billboard itself (optimus head). Holding or hanging off this may bend it out of shape or damage it, and could lead to a fall or an accident.
- To avoid electric shock, check to see if door & cover parts are damaged or omitted.
- To avoid electric shock, short circuit and/or parts damage, do not put the following items on or in the periphery of the product:
 - Flower vases, flowerpots, cups, water tanks, cosmetics, and receptacles/containers/vessels containing chemicals and water.

⚠ CAUTION

- To avoid injury, be sure to provide sufficient space by considering the crowd situation at the installation location. Insufficient installation space can cause customers to bump into each other, causing trouble.
- Every day when cleaning the Control Unit (Gun), inspect the gun and make sure that there are no scratches or cracks in the surface, and that the fastening screws are not loose. If the game is played with scratches, cracks or loose screws, it can cause injuries to the player or to people nearby.

Ensure that the trigger is functioning properly.

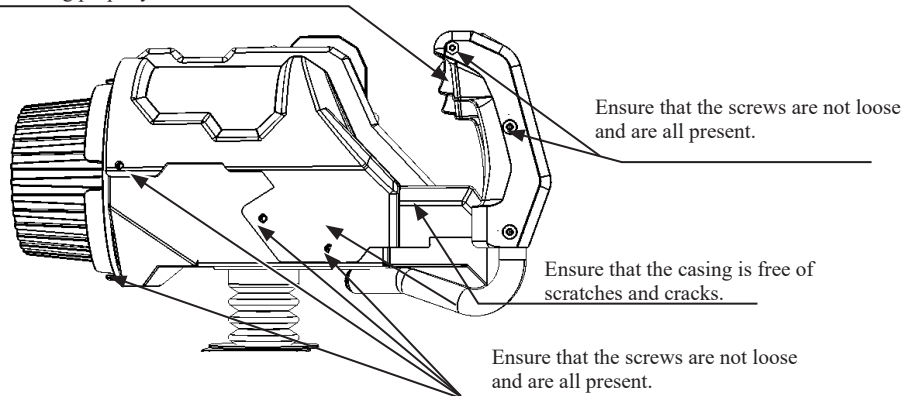

- When you clean the cabinet each day, always make sure that there is nothing placed on the seats and that they are not damp or wet. The construction of this product may allow for willful misconduct by players.

STOP IMPORTANT

To ensure customers enjoy playing the game, clean the Control Unit regularly. If there is any dirt buildup, the trigger may not return properly after being pulled.

3-2 DURING OPERATION (PAYING ATTENTION TO CUSTOMERS)

To avoid injury and trouble, be sure to pay attention to the behavior of visitors and players.

WARNING

- For safety reasons, do not allow any of the following people to play the game:
 - Those who require supporting devices, etc., to walk.
 - Those who have high blood pressure or a heart problem.
 - Those who have experienced muscle convulsion or loss of consciousness when playing video games, etc.
 - Those who have neck or spinal cord problems.
 - Intoxicated persons.
 - Pregnant women.
 - Persons susceptible to motion sickness.
 - Persons who disregard the product's warning displays.
- Even players who have never been adversely affected by light stimulus might experience dizziness or headache depending on their physical condition when playing the game. Small children are especially likely to experience these symptoms. Caution guardians of small children to keep watch on their children during play.
- Instruct those who feel sick during play to have a medical examination.
- To avoid injury from falls and electric shocks due to spilled drinks, instruct the player not to place heavy items or drinks on the product.
- To avoid electric shocks and short circuits, do not allow customers to put hands and fingers or extraneous matter in the openings of the product or small openings in or around the doors.
- To avoid falls and resulting injury, stop the customer from leaning against or climbing on the product, etc.
- To avoid electric shock and short circuit, do not allow customers to unplug the power plug without a justifiable reason.

CAUTION

- Immediately stop violent acts such as hitting and kicking the product. Such violent acts can cause parts damage or falling down, resulting in injury due to fragments and falling down.
- Two or more players must never be allowed to play using a single Control Unit. Playing in such a way could lead to physical injuries.
- When entering or exiting the machine, players may trip over the base. Be sure to warn players who do not appear to be exercising proper caution.

IMPORTANT

The interior of the cabinet is hard to see from the outside which may lead to willful misconduct by players or accidents going unnoticed. When the game is not in use, check the interior at regular intervals and make sure that nothing has been forgotten or placed on the seats.

4 PARTS DESCRIPTION

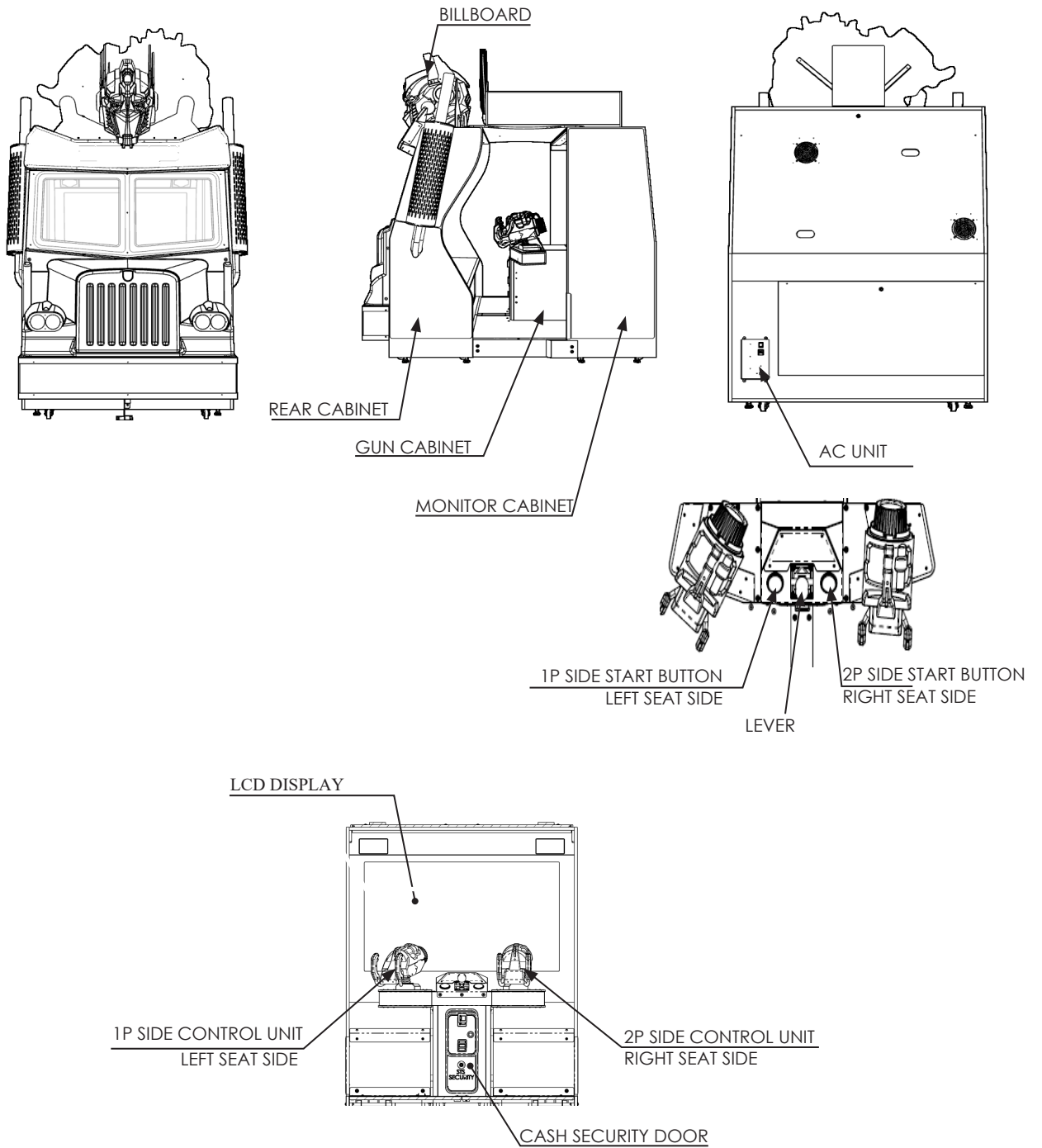

FIG. 4 Name of Each Part

- In this product, the Cabinet which houses the LCD display screen shall be referred to as the Monitor Cabinet
- Facing the LCD display screen, the left side is the 1P seat and the right side is the 2P seat.

5 ACCESSORIES

Confirm that the accessories listed in the table below are present when setting up the product. Accessories marked “Spare” in the note column are consumable items but included as spares.

TABLE 5a

OWNER’S and SERVICE MANUAL
420-0030UK (1)
This manual

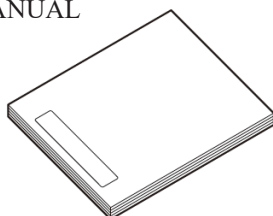

KEY
(2)
For the cashbox door
(Located inside the coin chute
door at time of shipment)

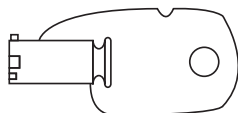

MASTER KEY
220-5575UK (2)
For opening/closing the doors
(Packaged with this manual, in the
box supplied with the product)

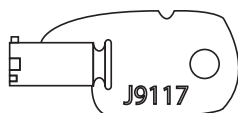

PLAY INSTR SHEET MULTI
TS-1914-XXUK where “xx denotes language
01 - English (fitted)
02 - French
03 - Turkish
04 - Italian
05 - Spanish
06 - Russian



STICKER SHEET C EPILEPSY MULTI
440-CS0186UK (1)
Multilingual caution label - epilpsy seizure
(English verion fitted as standard)
Please see chapter 1 for label positioning.



The parts listed in Table 5b are needed to operate the product. These are the final parts used once installation assembly has been completed.

TABLE 5b

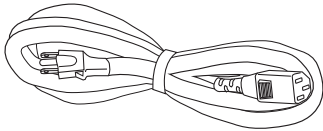
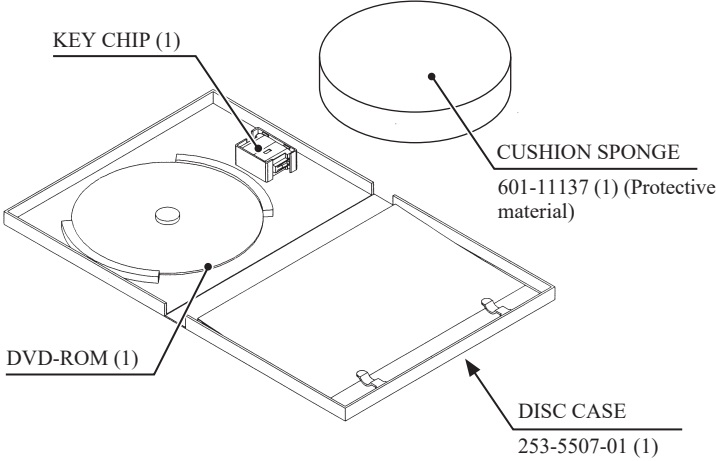
<p>POWER CABLE LM1227 (1) <UK> LM1246 (1) <European> LM1550 (1) <America> For installation, see chapter 6</p>	<p>STICKER 840-0012D-02 443-40012D-02 (1) Board number stickers, see chapter 6</p>	<p>844-0012D-02</p>
	<p>DVD SOFTWARE KIT (1) Software media, see chapter 6</p>	 <p>KEY CHIP (1)</p> <p>CUSHION SPONGE 601-11137 (1) (Protective material)</p> <p>DVD-ROM (1)</p> <p>DISC CASE 253-5507-01 (1)</p>
<p>To order the DVD-ROM by itself, use the following part number: 610-0816-5026 (DVD SOFT TC1 JESRFIGSPTR).</p>		

DVD DRIVE and DVD wire are sold separately but they are required for installing the product's software. If they were not provided when the product was delivered, consult with the point of purchase, or arrange to obtain the following kit numbers. The DVD DRIVE, DVD wire and INSTALLATION wire that are accessories to "Dream Raiders" can also be used with this product.

TABLE 5c XKT-1515-01: DVD DRIVE KIT FOR RING EDGE 2 ENG

DVD DRIVE (Optional)
 610-0719-01-91 (1)

INSTALLATION WIRE (Optional)
 BRK-60219 (1)

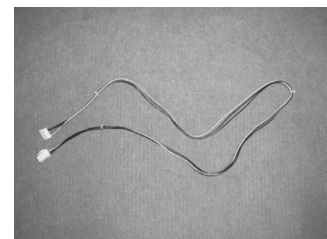
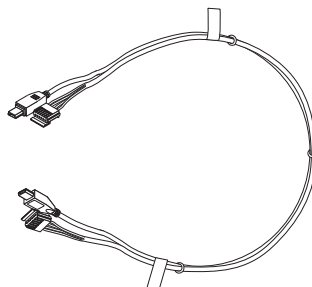
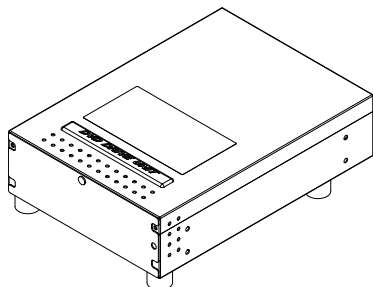

DVD WIRE (Optional)
 605-0094 (1)

6 ASSEMBLY AND INSTALLATION

WARNING

- Perform assembly work by following the procedure herein stated. Failure to comply with the instructions can cause electric shock.
- Perform assembling as per this manual. Since this is a complex machine, incorrect assembling can cause an electric shock, machine damage and/or improper functioning as per specified performance.
- When assembling, more than one person is required. Depending on the assembly work, there are some cases in which working by one person alone can cause personal injury or parts damage.
- Ensure that connectors are properly connected. Improper connections can cause electric shock.
- Be careful not to damage the wires. Damaged wires may cause electric shock or short circuit or present a risk of fire.
- This work should be carried out by site maintenance personnel or other qualified professionals. Work performed by non-technical personnel can cause a severe accident such as electric shock. Failing to comply with this instruction can cause a severe accident such as electric shock to the player during operation. If no one with proper technological expertise is available, request service from the office indicated in this document or the point of purchase so as to ensure safety.
- Provide sufficient space so that assembling can be performed. Performing work in places with narrow space or low ceiling may cause an accident and assembly work to be difficult.
- To perform work safely and avoid serious accident such as the cabinet falling down, do not perform work in places where step-like grade differences, a ditch, or slope exist.
- Do not leave power cords or ground wires exposed in areas of heavy foot traffic. Doing so may cause them to become damaged, possibly resulting in electric shock and/or short circuits. When laying wiring across the floor, always use safety covers to protect the wires. (Wiring diameter: power cable - approx. \varnothing 8)
- Have a flashlight or another supplementary lighting unit available while working. With indoor lighting alone, the cabinet interior may be too dark. Working without proper lighting can lead to accidents. It also hinders proper work performance.
- The cabinet has ventilation ports. Be sure not to block them. If they are blocked, heat can build up, leading to fire. This can also accelerate wearing of parts and malfunctions.
- Secure ample ventilation space around the cabinet. If heat builds up, there could be accidents associated with heat or smoke generation.
- Do not unnecessarily push the projector. This could cause the unit to tip over.
- This product does not use any connectors other than those connected to and used by the game board when it leaves the factory. Do not needlessly connect wires to unused connectors. This could lead to overheating, generation of smoke and burn related injuries.

 **CAUTION**

- Handle molded parts with care. Excessive weight or pressure may cause them to break and the broken pieces may cause injury.
- To perform the operation safely and accurately you must use a safe, steady footstool or stepladder. Working without this may lead to a fall and possible injury.
- When connecting the connectors on the DVD wire, you must carefully check the tags on the wire to find the correct connector. Even when you have the correct connector, you must pay careful attention to the direction and angle of insertion. Attempting to forcefully connect the incorrect connector or connecting a connector at the wrong angle or facing may damage the connector and could lead to overheating and burn related injuries.
- When attaching or removing doors or lids, be careful that your hand or finger does not get caught in anything.

 **IMPORTANT**

- Be very careful when handling the LED display screen. The screen can be damaged easily and cannot be repaired once damaged. Such damage can only be repaired by completely replacing the screen.
- Be careful not to damage parts surfaces. In some cases, if such surfaces are damaged, the part must be replaced; it cannot be reinforced or repaired.

Tools Required for Assembly Operation

- Philips screwdriver (for M4, M6 screws)

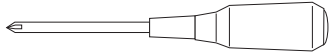

- A socket wrench or hexagonal screwdriver (for M4, M6 and M8 hexagon bolts/nuts)

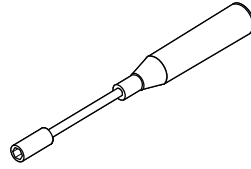
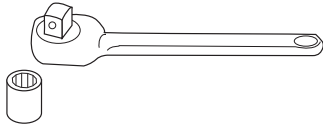

- A 2.5, 4 and 5 millimeter hexagonal bar wrench or screwdriver

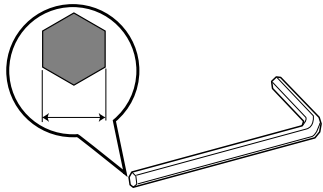

- Flashlight

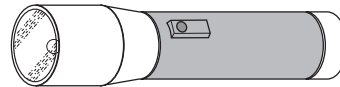

- A 24 millimeter spanner (Adjustable spanner)

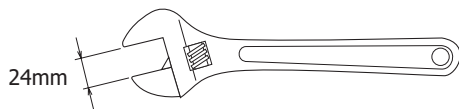

- Stepladder

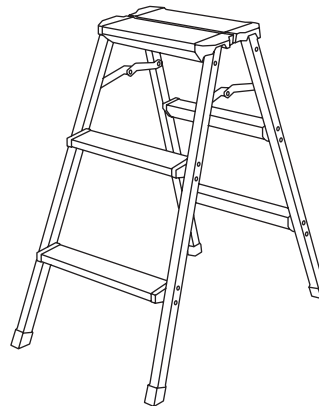

- Master key (accessory)

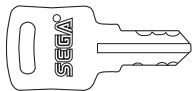

6-1 UNPACKING THE CABINET

Check parts required for installation

There are numerous components and brackets required to fully prepare the cabinet for operation. Detailed below are a list of all parts required to fully install the machine and their whereabouts upon first unpacking the cabinet. Note: "Within Situ" means that the part is located in place on the cabinet, but requires the securing fixings to be removed and then resecured after the necessary installation steps have been taken.

PART	LOCATION
ASSY ROOF	Shrink wrapped to REAR CABINET
ASSY EXHAUST PIPE (X2)	Placed within REAR CABINET
ASSY BILLBOARD	Placed within REAR CABINET
ASSY JOINT GUN CABI REDUCED	Top Box packaging
ASSY JOINT BRIDGE (X2)	Placed within REAR CABINET
ASSY FLOOR PANEL (L & R)	On either side of REAR CABINET
MID SASH	Attached to one of two FLOOR PANELS
JOINT SASH SIDE (L & R)	Top Box packaging
REAR SASH	Within Situ
BRKT FRONT JOINT TOP (X2)	Within Situ
POP PANEL	Placed within REAR CABINET
POP PANEL SUPPORT BRKT	Placed within REAR CABINET
ASSY TOP BOX (LIGHT BOX)	Top Box packaging
BRKT SUPPORT SHOULDER (X2)	Secured to inner walls of REAR CABINET
ASSY SEAT	Secured to REAR CABINET
RODENT SHUT OFF	Placed within REAR CABINET
OP SHOULDER (L & R)	Placed within REAR CABINET

Below is a illustrated diagram of the components required to carry out assembly and installation of this cabinet:

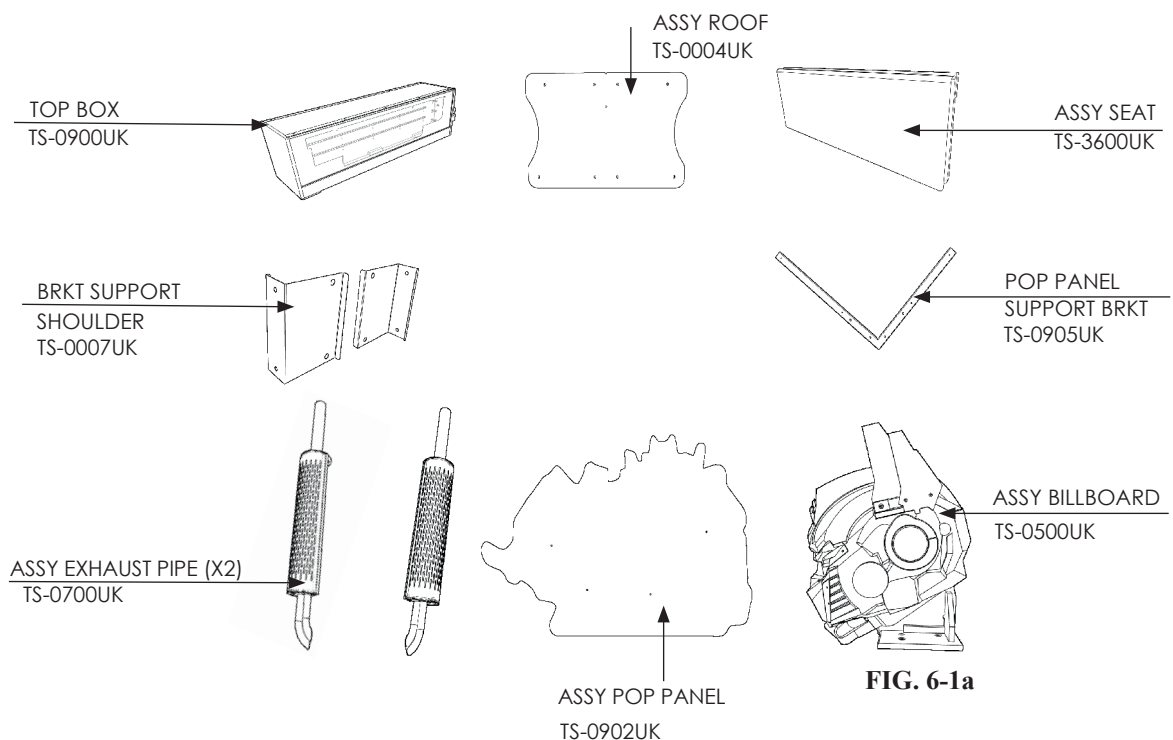

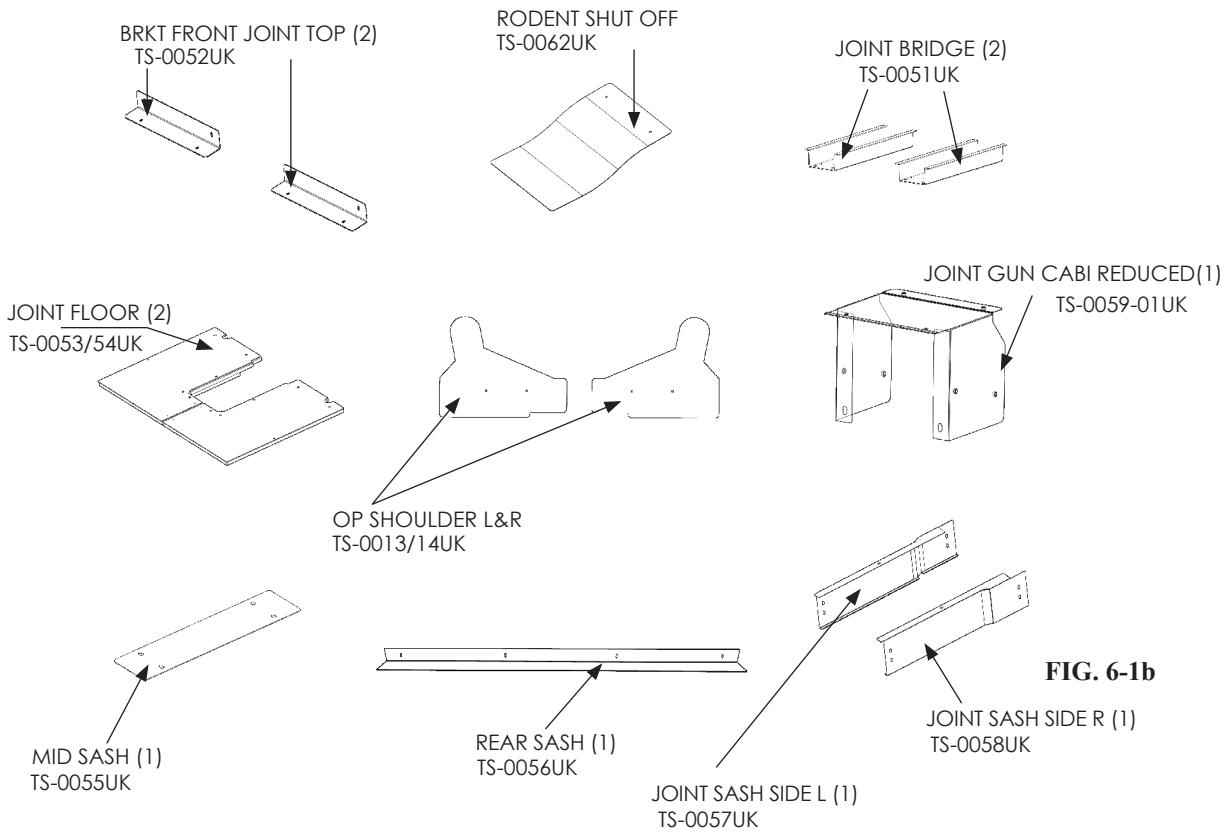

Below is a illustrated diagram of the where the previously listed components and brackets can be found after unpacking the cabinet.

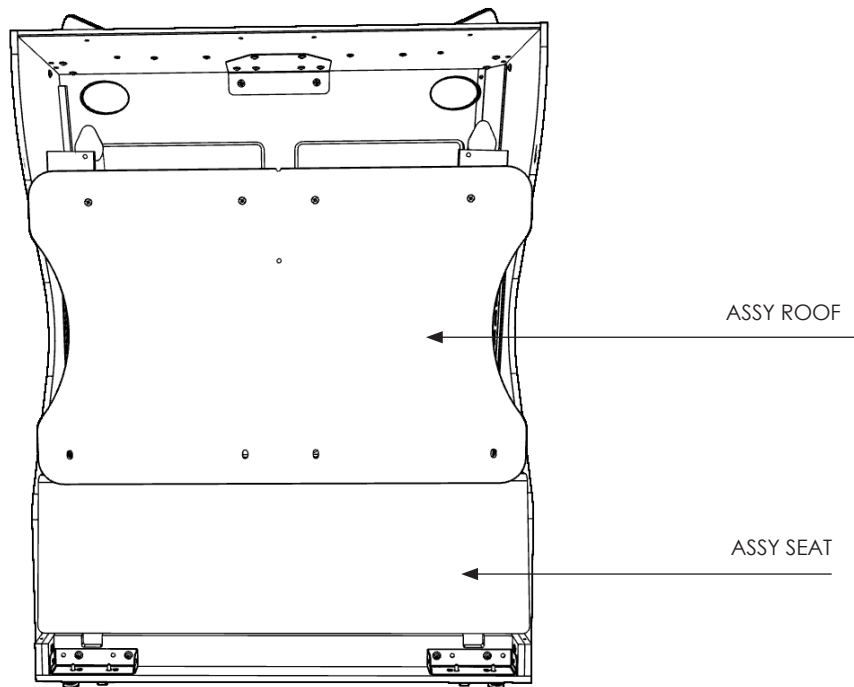

FIG. 6-1c

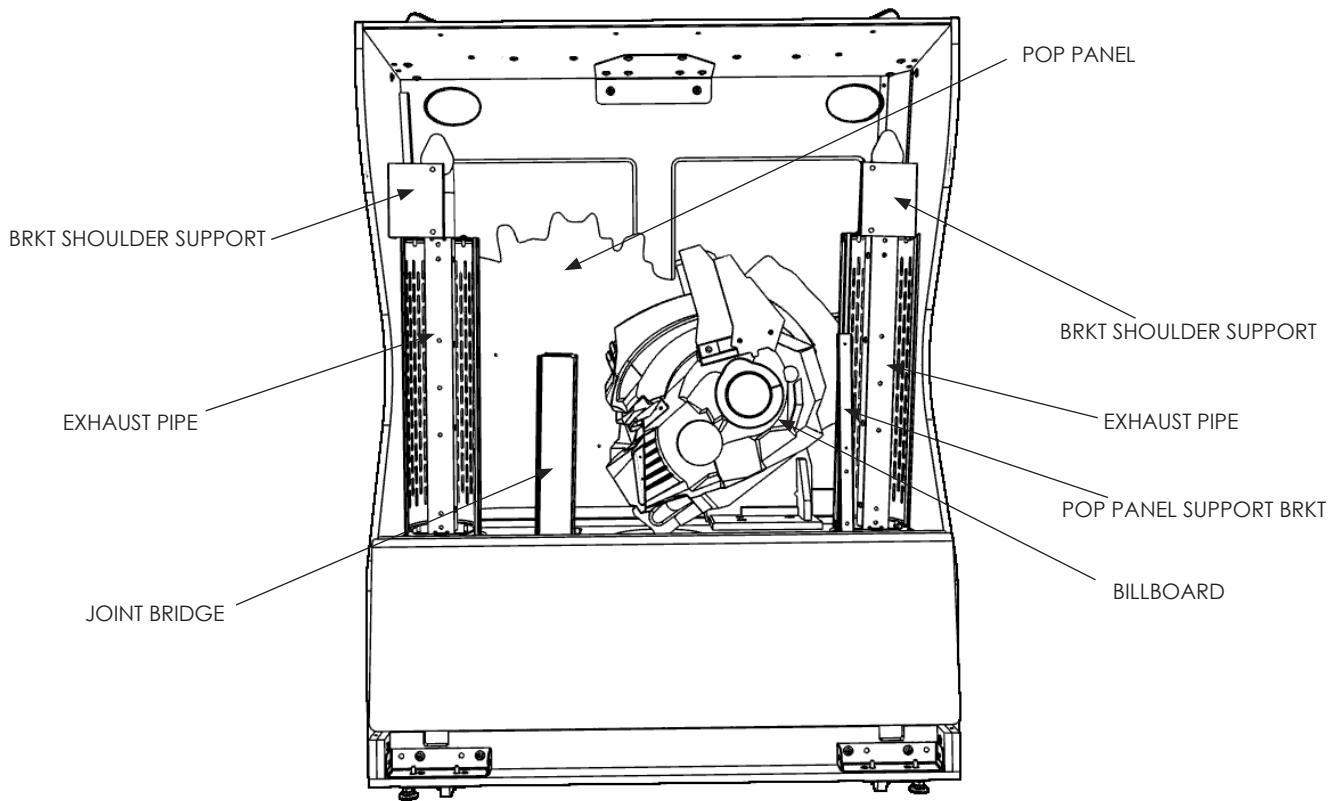

FIG. 6-1d

In this product the cabinet that contains both the MONITOR cabinet and GUN cabinet and will be simply referred to as the “MONITOR cabinet”

- 1 Carefully unpack the machine. Locate the parts listed below and place to one side. Remove the 2 parts of the machine from the pallet (Monitor cabinet and Rear cabinet) using suitable lifting equipment.

Please note:

During transit the roof for this machine is placed inside the seating of the REAR CABINET with the Billboard and Exhaust Pipes. Some components and brackets are also contained within the Top Box container.

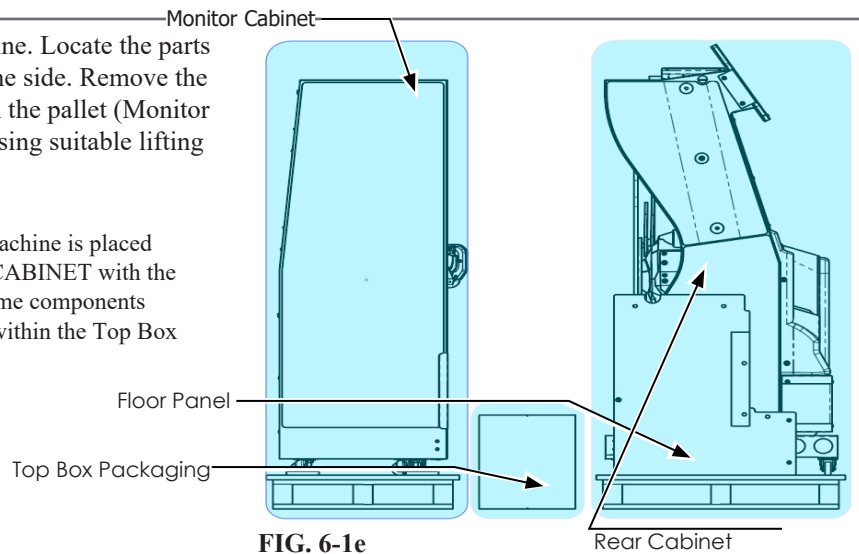



FIG. 6-1e

STOP IMPORTANT

- Be very careful when removing the Monitor and Rear cabinets from the pallet. Use only hydraulic lifting equipment such as a fork lift. DO NOT attempt to remove the machine from the pallet by hand. Doing so may result in serious personel injury and/or damage to the cabinet and its components.
- There are 4 “LIFTING POINTS” highlighted on the lower front and rear parts of the machine by a  symbol. Always use these points when lifting.

6-2 ATTACHING THE EXHAUST PIPES

CAUTION

- Use at least two people when carrying out this operation. Trying to carry out this work single handedly may result in injury or component damage.

- 1 Remove the (2) M8 fixings that secure the Exhaust Pipe to the inner seat and remove the Exhaust.

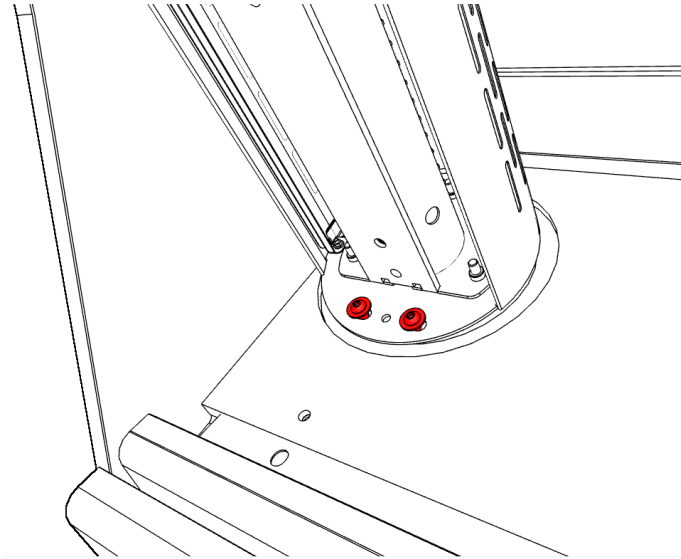

FIG. 6-2a

- 2 Have one person offer up the Exhaust Pipe and align with the fixing points shown.

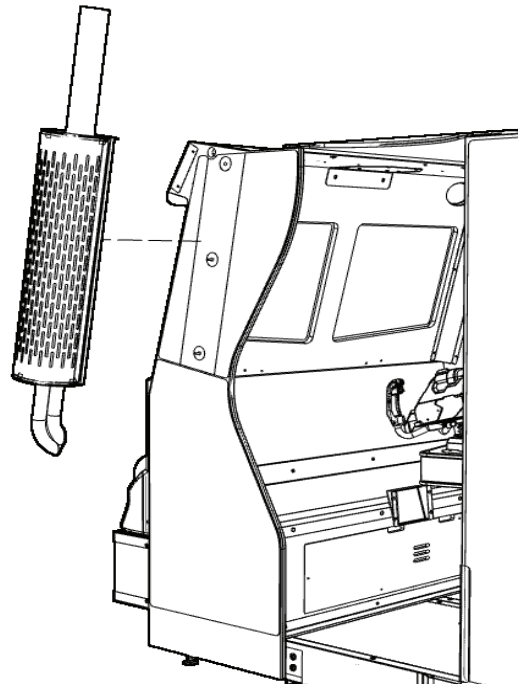

FIG. 6-2b

- 3** Using the (2) M8 fixings removed in Step 1, secure the Exhaust Pipe to the top of the REAR CABINET.

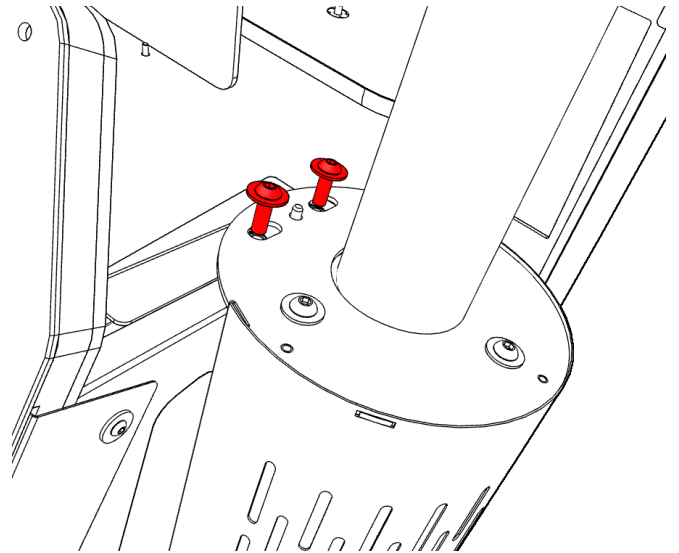

FIG. 6-2c

- 4** Attach the connector between the cabinet and the Exhaust Pipe via the hole shown.

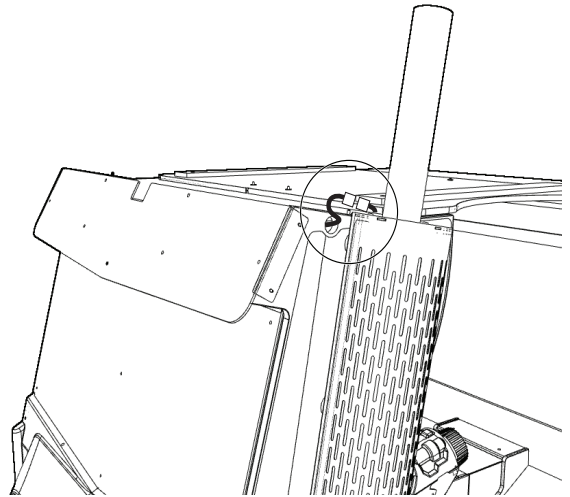

FIG. 6-2d

- 5** .Secure the exhaust pipe using the (3) M8 fixings on the interior of the cabinet. Follow the same procedure to fit the remaining Exhaust.

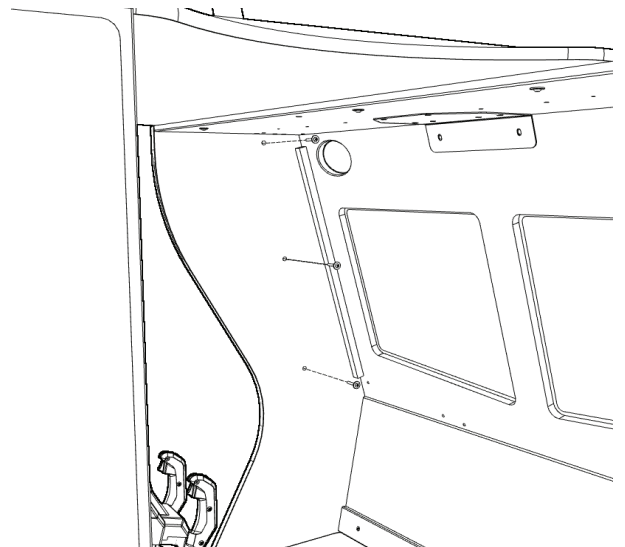

FIG. 6-2e

6-3 ATTACHING THE SEAT

- 1 Remove the seat panel by unfastening the (2) M8 fixings securing the transit brackets holding it in place.

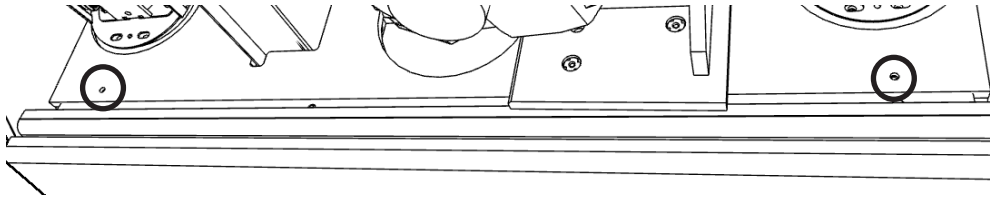

FIG. 6-3a

- 2 Starting at an angle, place the seat panel into position, taking care not to trap or damage the harnessing wires. Feed the harnessing wire through the hole in the centre of the seat.

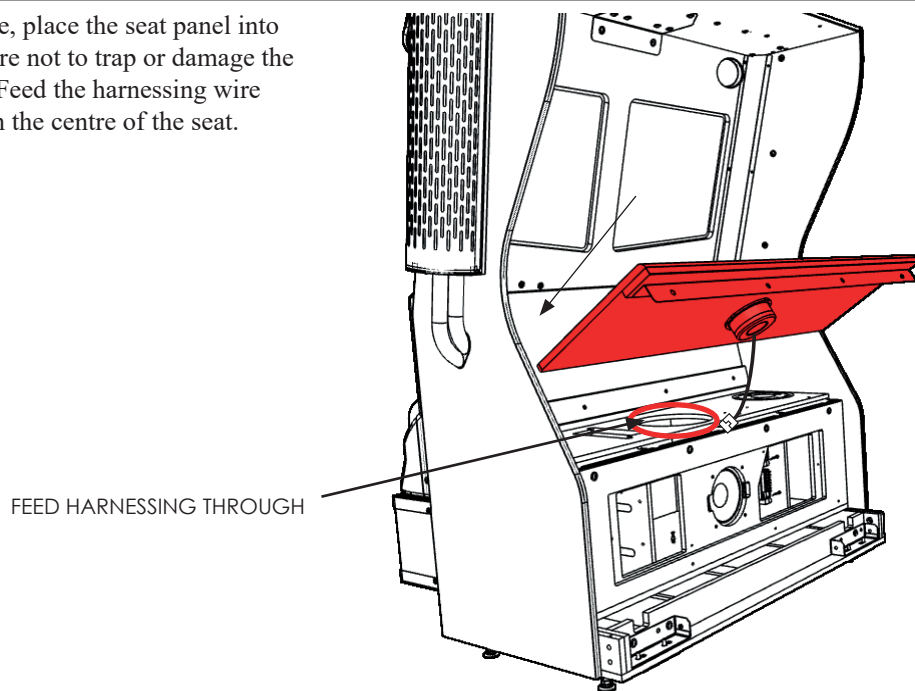

FIG. 6-3b

- 3 Position the harness wiring located underneath the seat towards the JOINT BRIDGE SECURE R. This will need to be connected to the harnessing from the MONITOR CABINET via the JOINT BRIDGE L when the two cab sections are joined together.

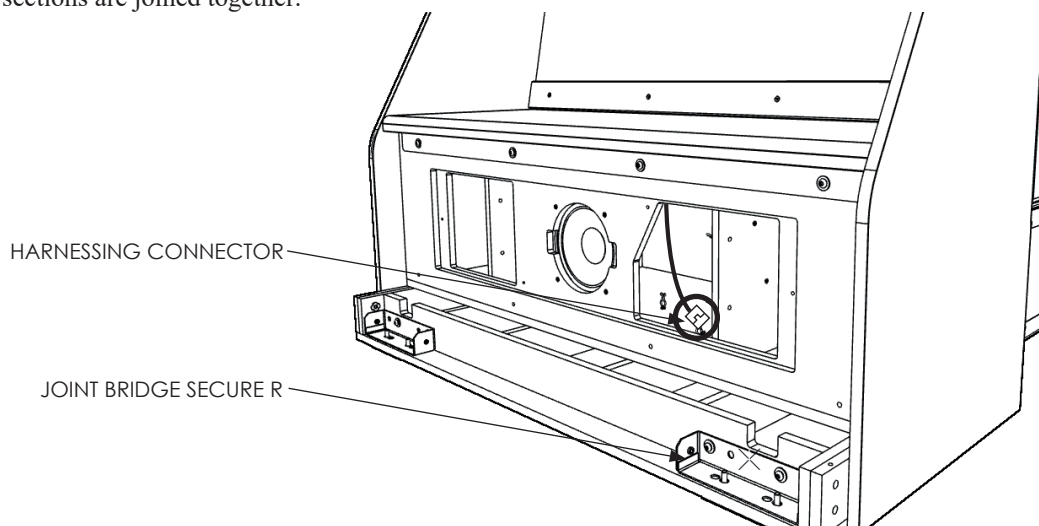

FIG. 6-3c

- Secure the seat panel with the (4) M8 fixings shown and place the DOOR SEAT LOWER in place.

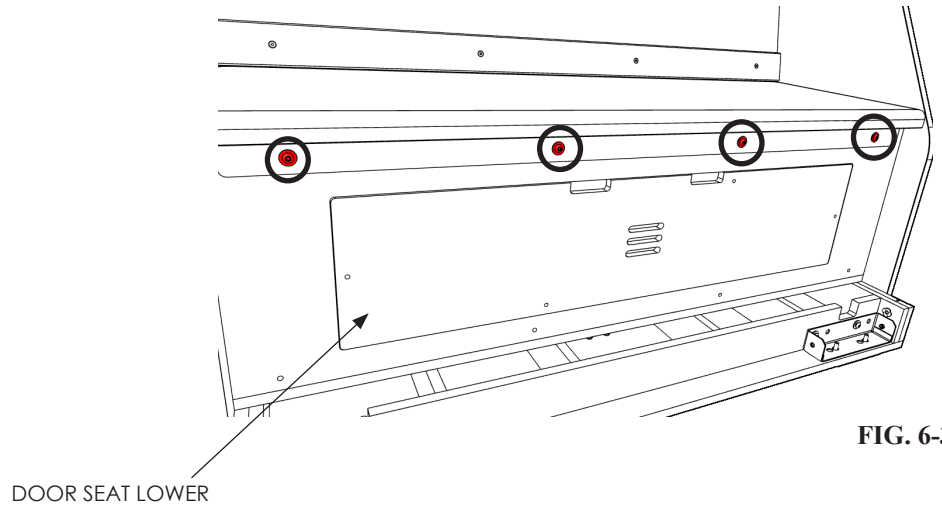

FIG. 6-3d

6-4 JOINING THE CABINETS

To correctly join the two cabinets together, the GUN CABINET must first be extended out and away from the MONITOR CABINET.

Extracting the GUN CABINET can be quite difficult, so it is recommended to apply the JOINT BRIDGE brackets and secure them to the REAR CABINET to provide some leverage.

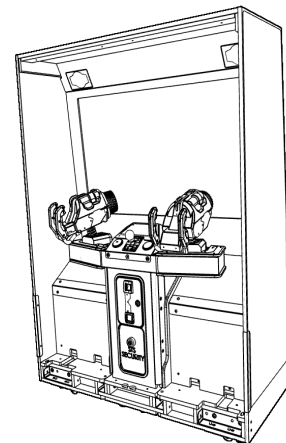

FIG. 6-4a

- Fix the JOINT BRIDGE L to the left hand side of the MONITOR CABINET using the PLATE JOINT BRIDGE SECURE. Secure the bracket using the high strength studs on the underside of the bracket. Follow the same procedure for the JOINT BRIDGE R on the right hand side. Align and secure to the REAR CABINET.

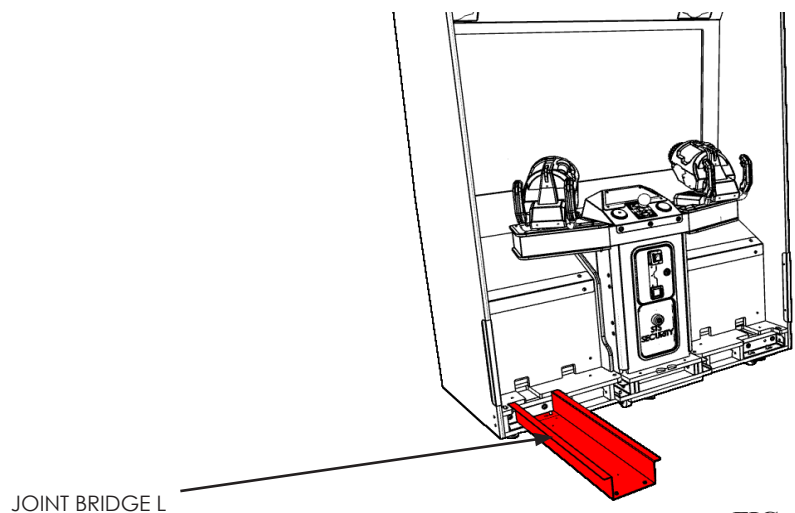
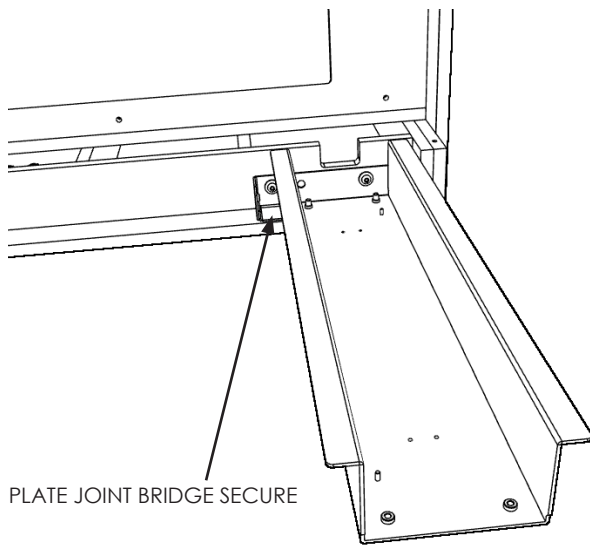
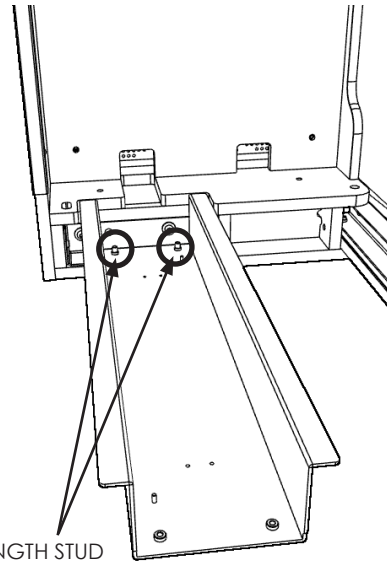

FIG. 6-4b



Fixings to Rear Cab



Fixings to Monitor Cab

FIG. 6-4c

2 After securing the JOINT BRIDGE units, on the left hand side (JOINT BRIDGE L), feed the wiring harnesses through the JOINT BRIDGE L and connect to the REAR CABINET harnessing.

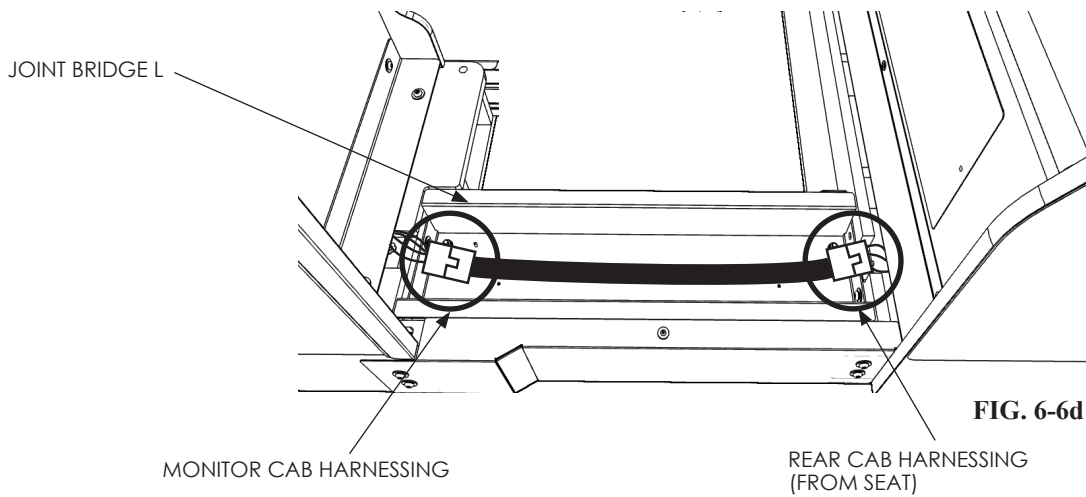

FIG. 6-6d

3 Remove the fixings securing the GUN CABINET.

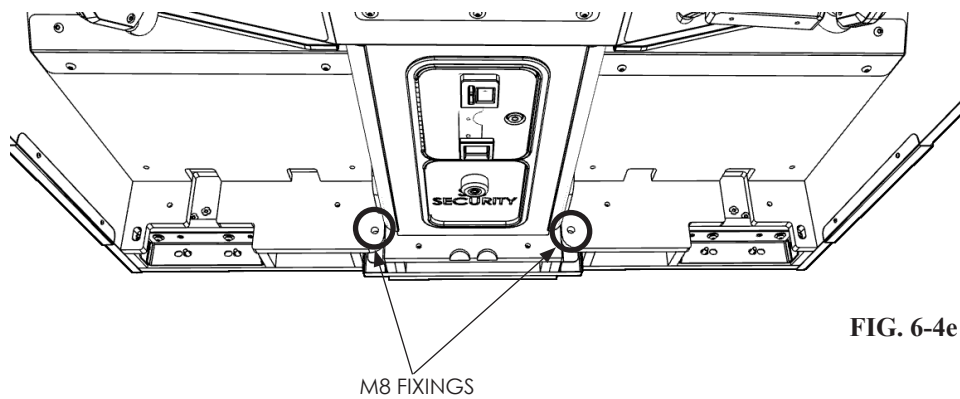
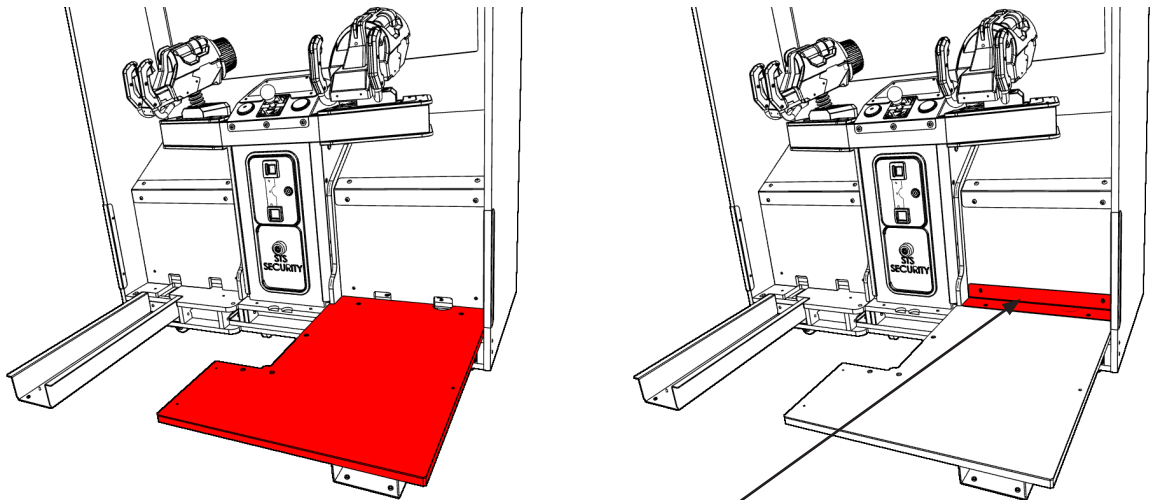

FIG. 6-4e

- Place the RH Floor Panel into position and secure using the BRACKET FRONT JOINT TOP (this bracket is in situ and must be removed before placing the floor panel and then reapplied).



BRACKET FRONT JOINT TOP

FIG. 6-4f

- Extend the Gun Cabinet fully, ensuring that the fixing points are aligned with those of the RH Floor Panel.

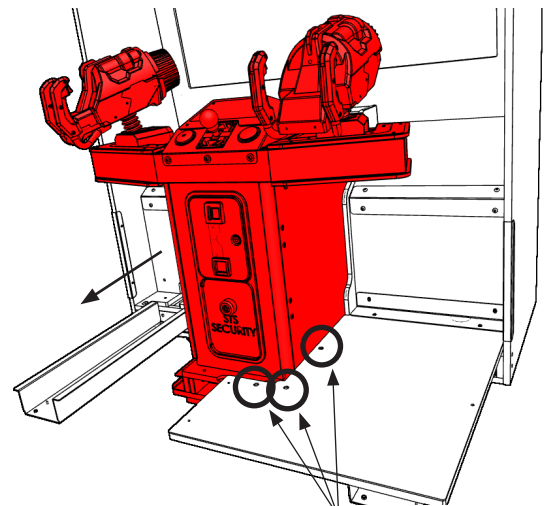

ALIGN FIXING POINTS

FIG. 6-4g

6-5 SECURING FLOOR PANELS

- Secure each of the floor panels with (3) Sockethead Screws on each side (two of which fixings were initially removed from the Gun Cabinet).

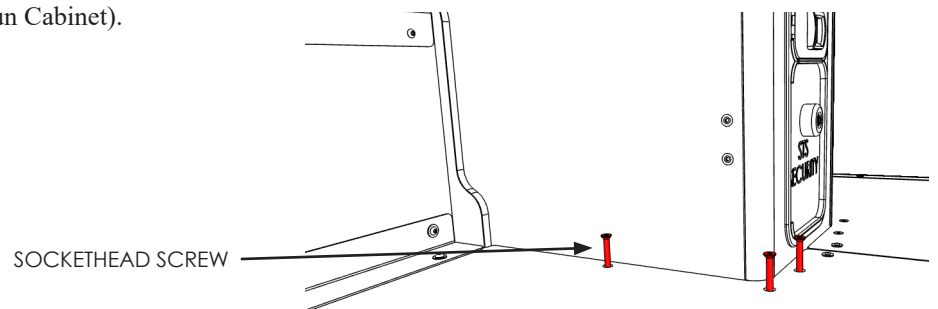

FIG. 6-5a

- 2** Secure the REAR SASH to the seat of the REAR CABINET using the (4) M4 fixings as shown.

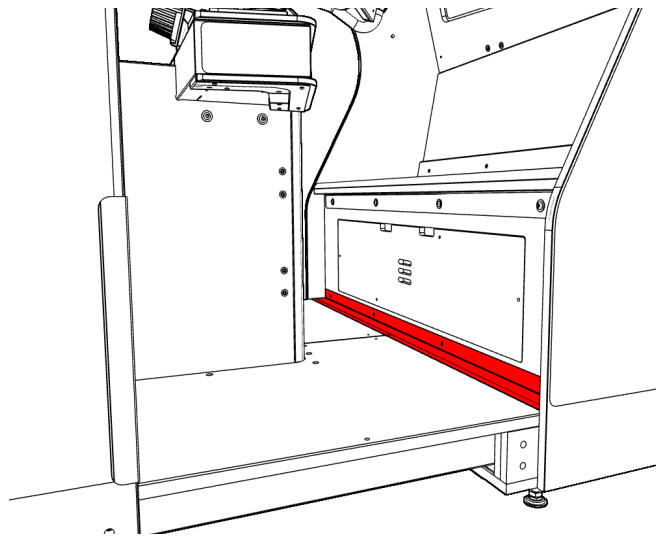

FIG. 6-5b

- 3** Secure the MID SASH using the (4) M4 fixings to secure the connection between the two FLOOR PANELS

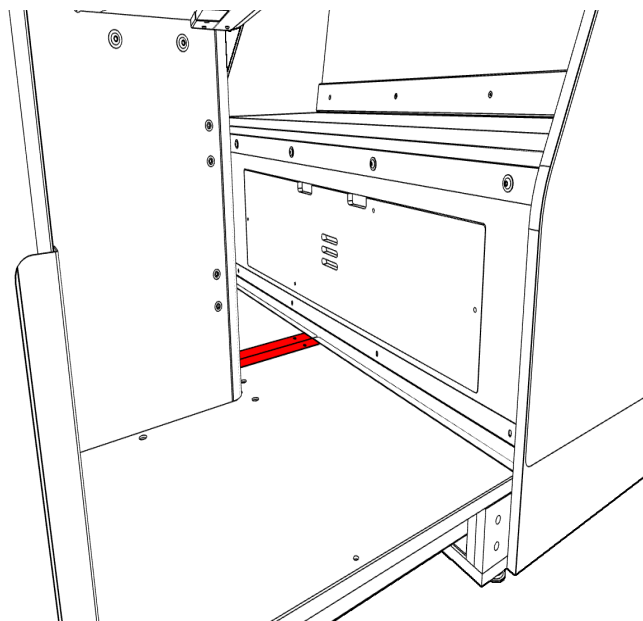

FIG. 6-5c

- 4** Secure the SIDE SASH L as shown using the (4) M8 fixings.

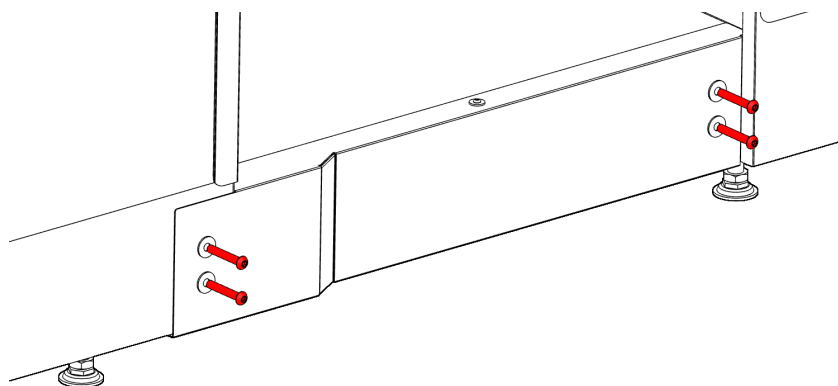

FIG. 6-5d

- Secure the top of the SIDE SASH L using the (1) M4 fixing as shown. Complete the same process for the SIDE SASH on the right hand side.

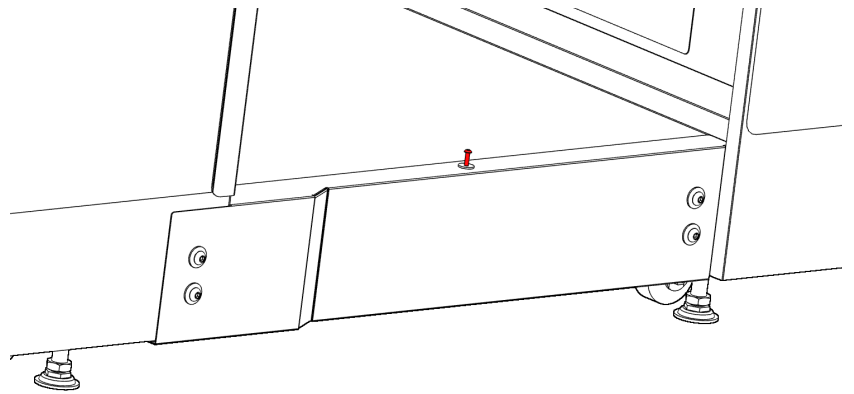

FIG. 6-5e

6-6 SECURING THE GUN CABINET

- Remove the Game BD access door to gain access to the internal fixings of the JOINT GUN CABI REDUCED. Have another person offer the JOINT GUN CABI REDUCED in place and secure all (4) M8 fixings.

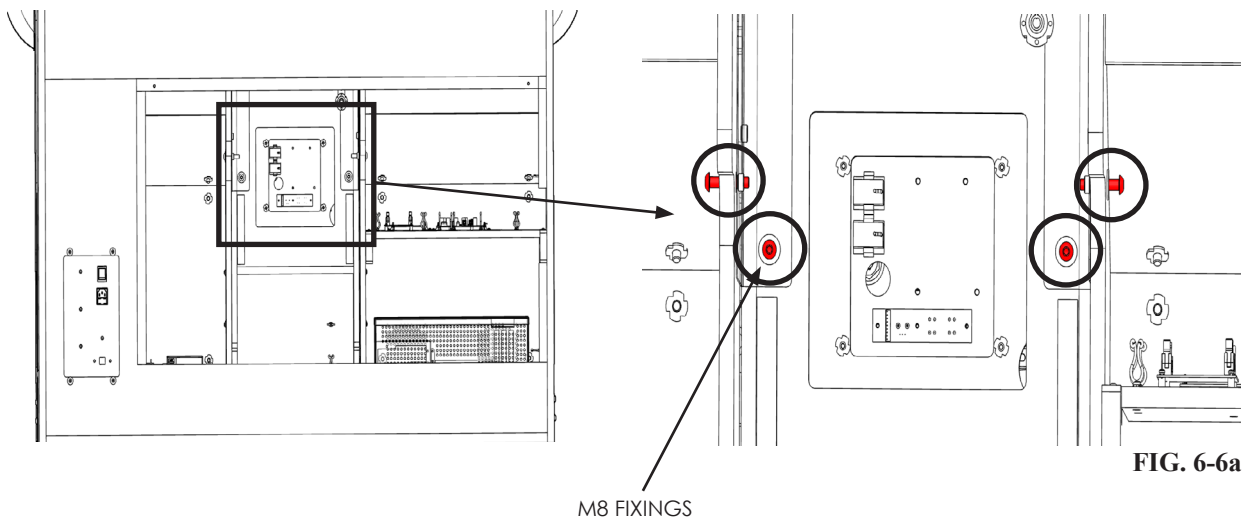

FIG. 6-6a

- Secure the (4) M8 fixings of the JOINT GUN CABI REDUCED

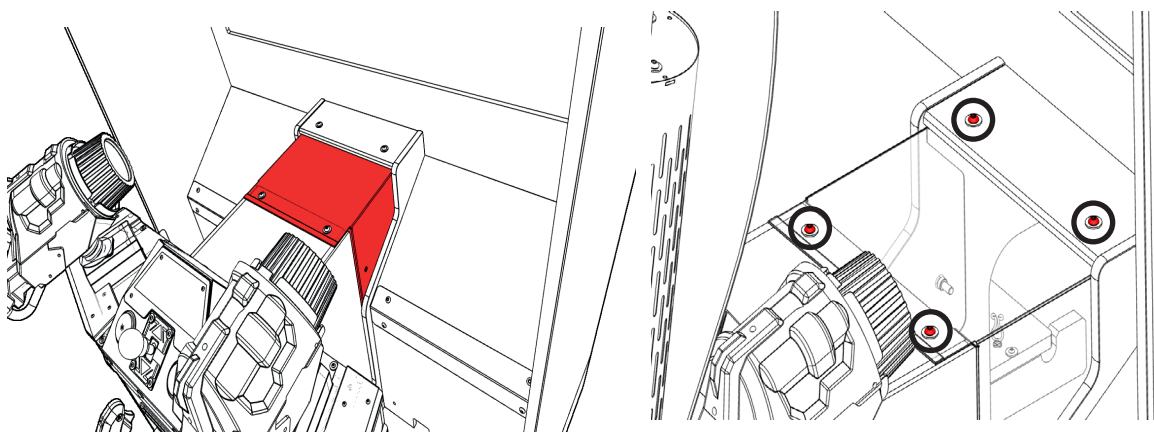
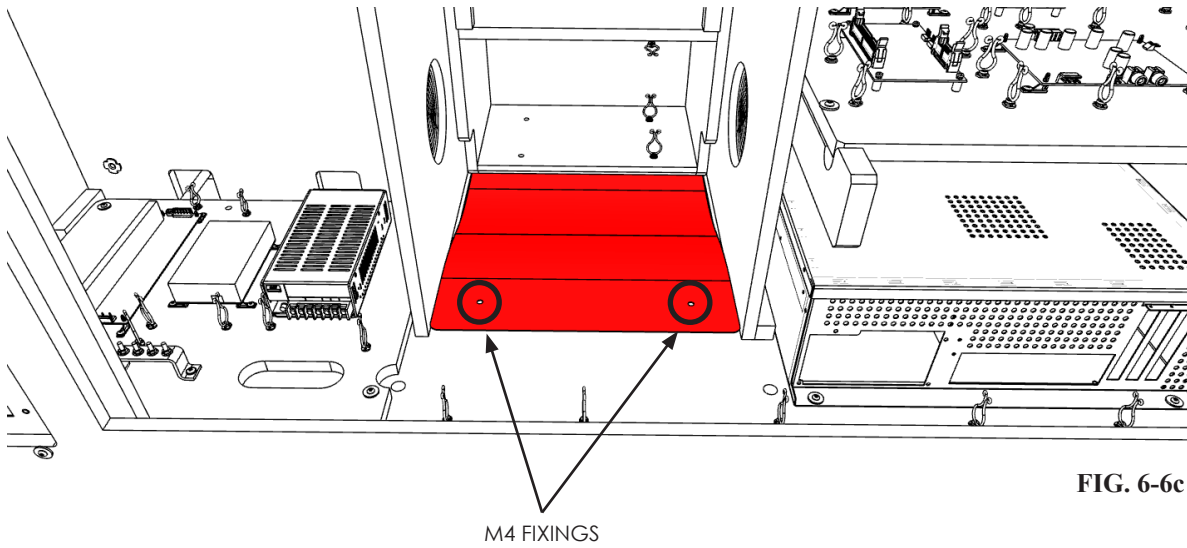

FIG. 6-6b

- 3** Once the GUN CABINET is secure, fix the RODENT SHUT OFF PANEL in place using (2) M4X25 fixings.



6-7 ATTACHING THE ROOF

- 1** Using 2 people, place the Panel Roof in the orientation shown on top of the cabinet.

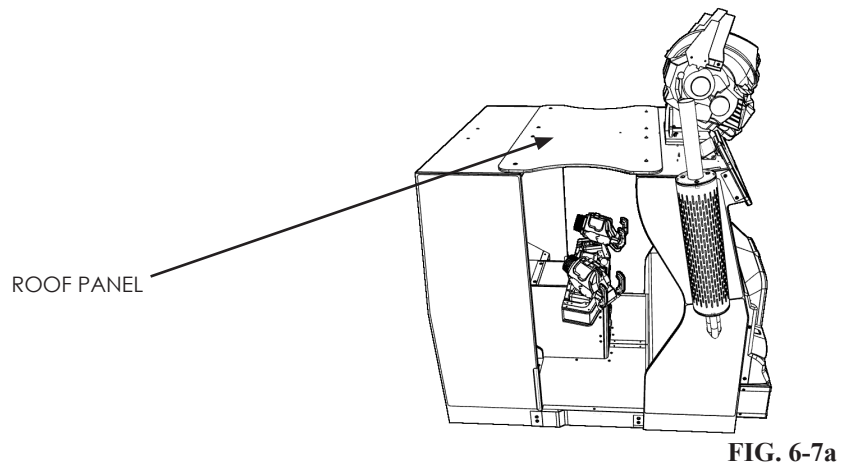

- 2** Secure the (4) M6 Fixings on top of the REAR CABINET in the orientation show (facing up and out of the cabinet).

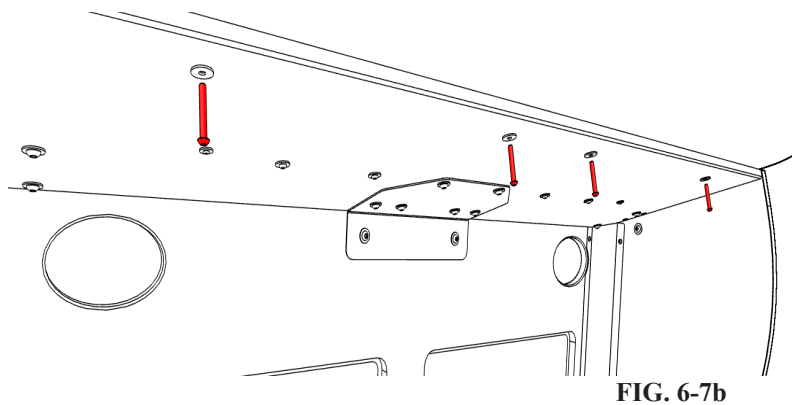

- Secure the (4) M6 Fixings on top of the MONITOR CABINET in the orientation show in illustration (facing down into the cabinet).

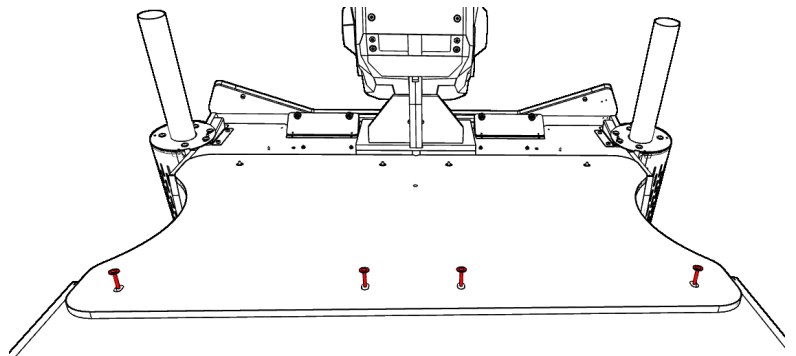

FIG. 6-7c

6-8 ATTACHING THE BILLBOARD (OPTIMUS HEAD)

CAUTION

- Handle molded parts with care. Excessive weight or pressure may cause them to break and the broken pieces may cause injury.
- Use at least two people when carrying out this operation. Trying to carry out this work single handedly may result in injury or component damage.

Whilst in transit, the Billboard is placed within the Rear Cabinet and secured with a single fixing. The Billboard weights in excess of 8kg. At least two people must work together to perform this operation. Some parts of the Billboard are fragile, so take care when handling.

- Align the billboard with the fixing points on the roof of the cabinet.

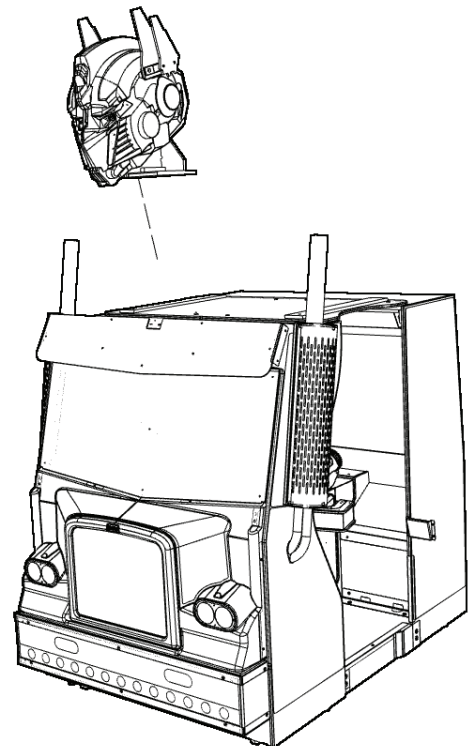

FIG. 6-8a

- 2** Attach the connector from the cabinet to the billboard in the position shown.

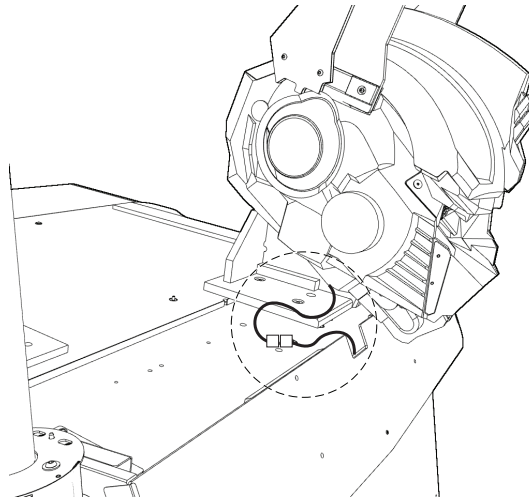

FIG. 6-8b

- 3** Attach the (4) M8 fixings to secure the billboard and BILLBOARD SUPPORT BRKT to the cabinet.

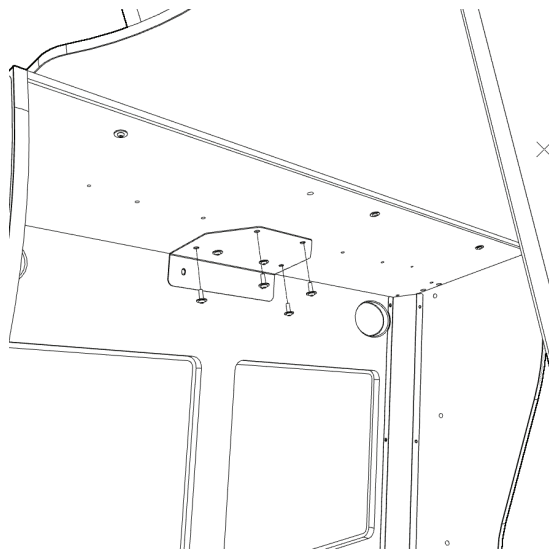

FIG. 6-8c

- 4** Assess that the billboard is stable after completing the installation

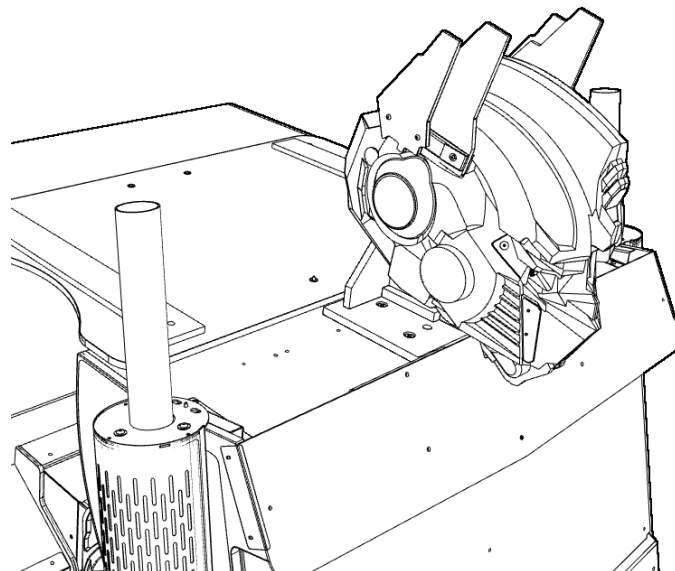

FIG. 6-8d

6-9 ATTACHING THE SHOULDER PANELS

- 1 Remove the BRKT SUPPORT SHOULDER from the interior of the REAR CABINET

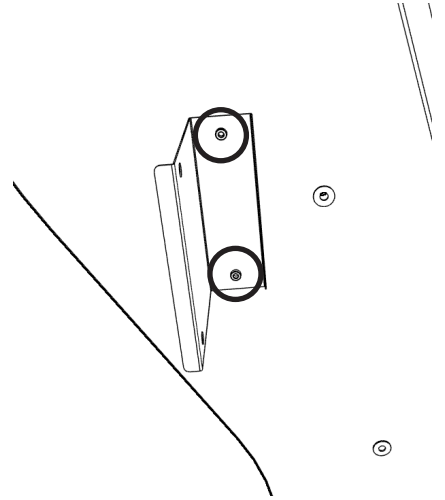

FIG. 6-9a

- 2 Secure the BRKT SUPPORT SHOULDER to the roof of the Rear Cabinet using the (2) M6 fixings. Note: these fixings are orientated “up”, meaning they are secured from inside the cabinet facing up and out.

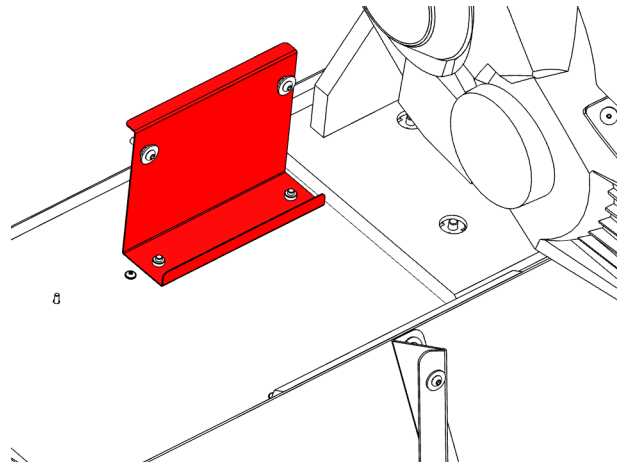

FIG. 6-9b

- 3 Remove the (2) highlighted M6 fixings. Place the pop panel graphic as shown in the illustration and reapply fixings to secure. Repeat this process for the right hand side.

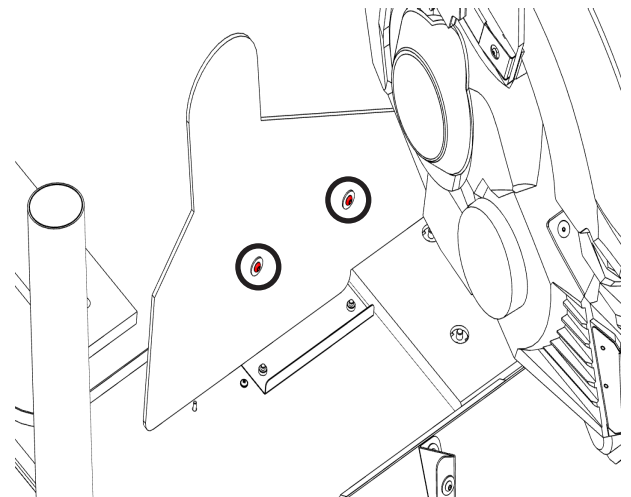

FIG. 6-9c

6-10 ATTACHING TOP BOX

CAUTION

- The Top Box weighs in excess of 20kg. Use at least two people when carrying out this operation. Trying to carry out this work single handedly may result in injury or component damage.

- 1 Using at least two people and adequate ladders and/or stepping equipment, raise the top box into position and align with the fixing points on the top of the cabinet.

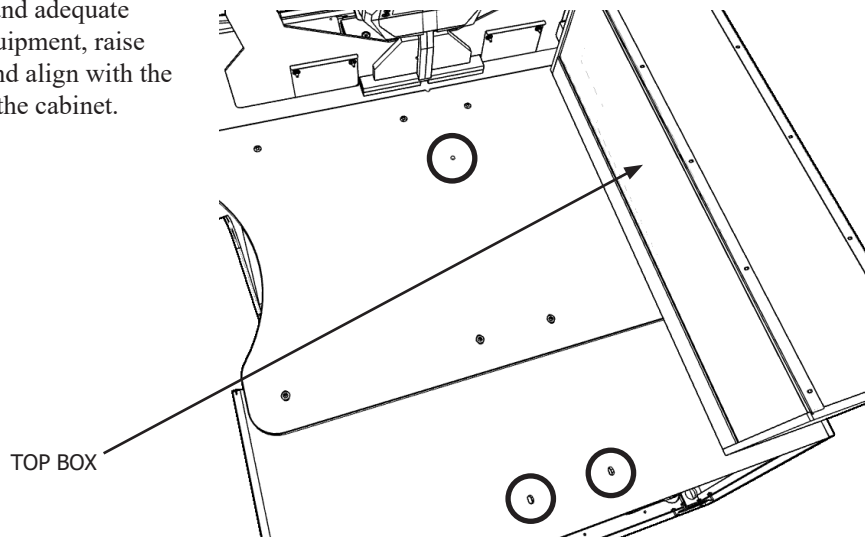

FIG. 6-10a

- 2 Secure the (1) M8 fixing within the ASSY ROOF PANEL in the orientation “up” (starting from inside the cabinet with the fixing facing out).

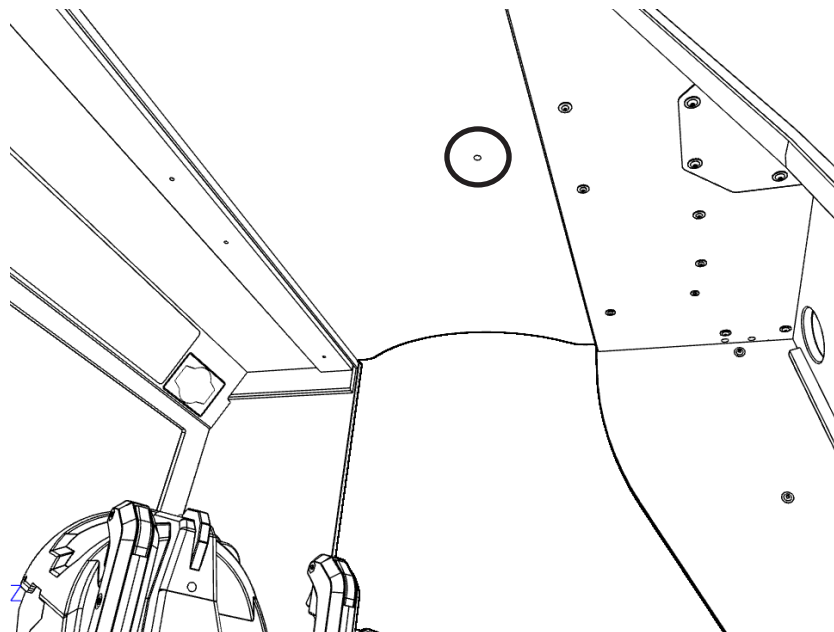

FIG. 6-10b

- 3 To access the (2) rear fixings, unlock and remove the upper access door.

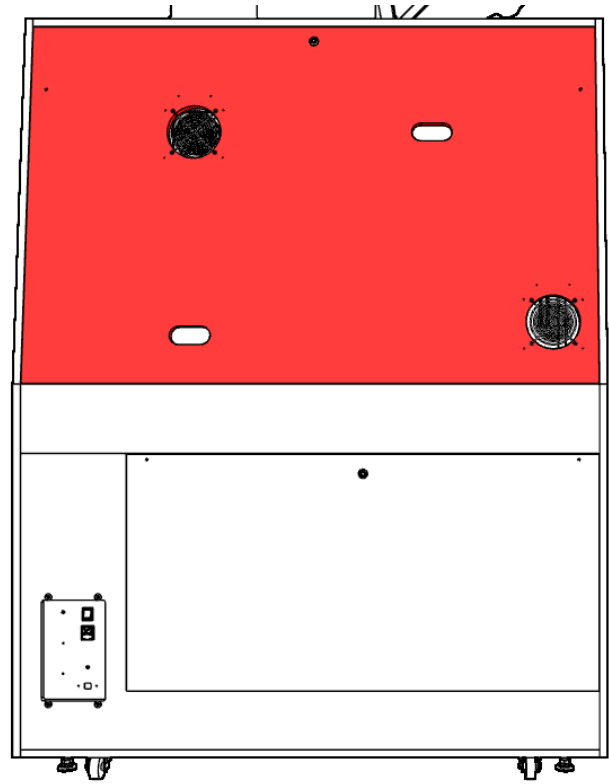

FIG. 6-10c

- 4 With the upper door removed, access and secure the (2) M8 fixings.

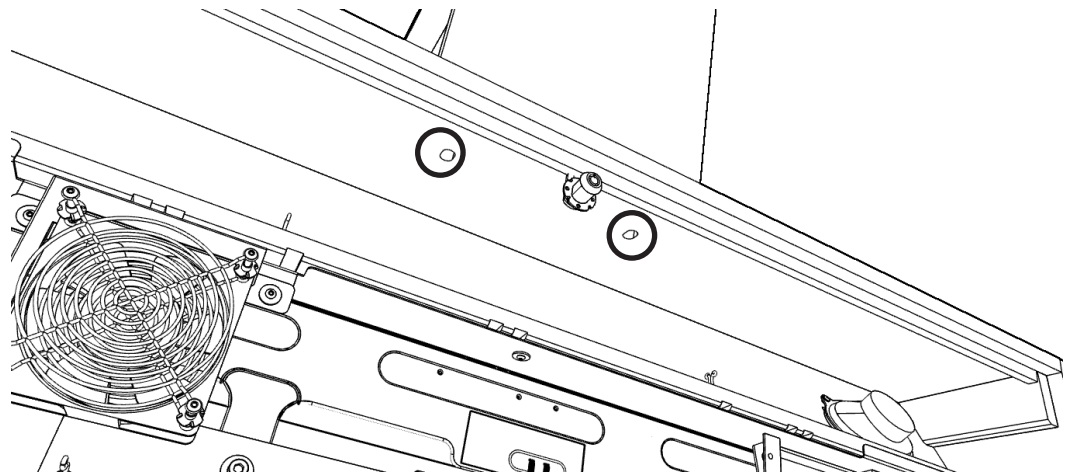
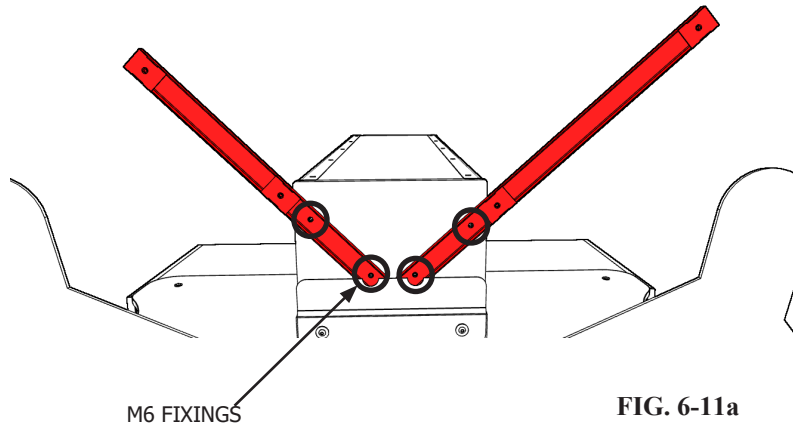

FIG. 6-10d

6-11 ATTACHING POP PANEL

- 1 Once the top box is secure, attach the POP PANEL SUPPORT BRKT using (4) M6 fixings shown.



- 2 Place the Pop Panel in place and secure with the (4) remaining M6 fixings.

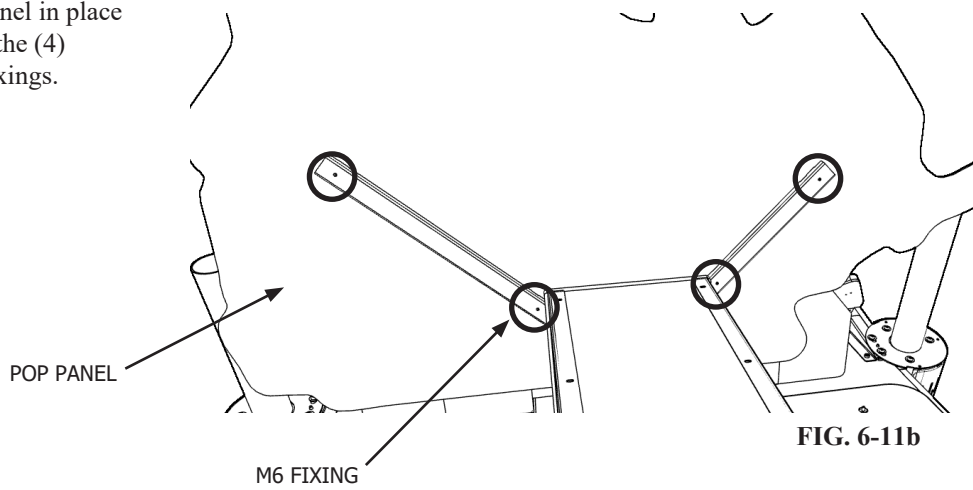

6-12 REMOVING TRANSIT BRACKET

- 1 Before fixing the cabinet to an area within the location, be sure to remove the transit bracket located at the bottom centre of the REAR CABINET.

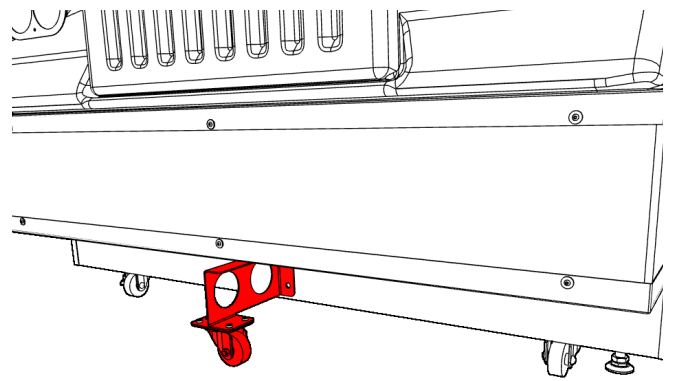

FIG. 6-12a

- 2 Remove the (4) M8 fixings (shown) and slide the transit bracket out from underneath the cabinet. Store the transit bracket in a safe place should the product need to be moved to another location in the future.

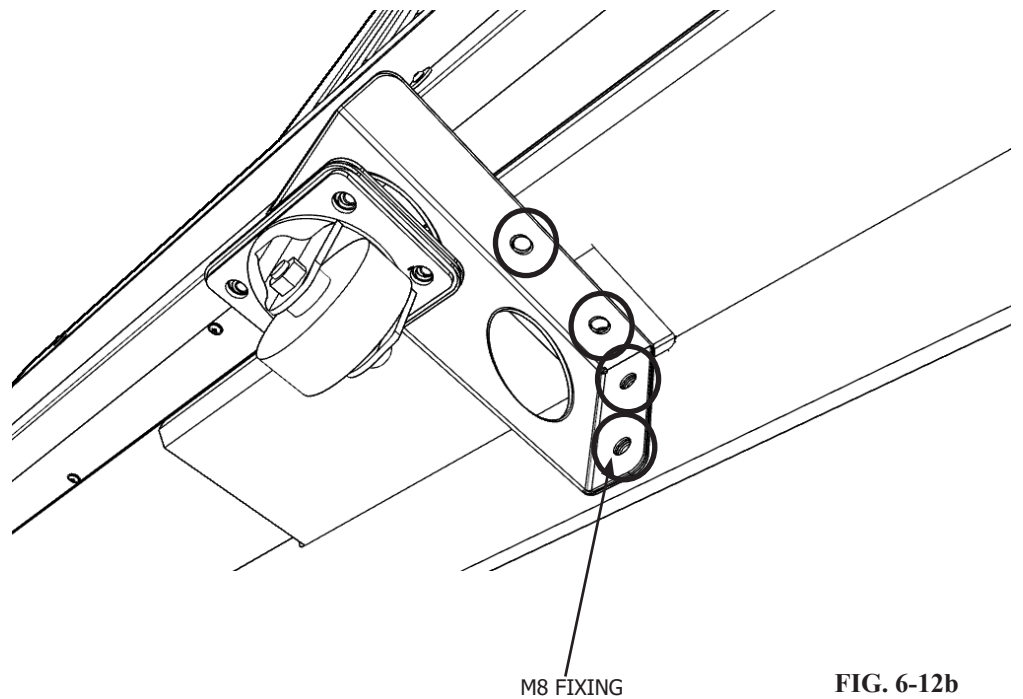

FIG. 6-12b

6-13 FIXATION TO INSTALLATION SITE

⚠ WARNING

Make sure that all the adjusters contact the floor. Otherwise the cabinet could move, causing an accident.

The product comes with casters attached at 11 locations and adjusters at 9 locations (Fig. 6-8a). When the installation site has been determined, have the adjusters come in direct contact with the floor. Establish a gap of about 5 mm between the floor and the casters and adjust the unit so that it will remain level.

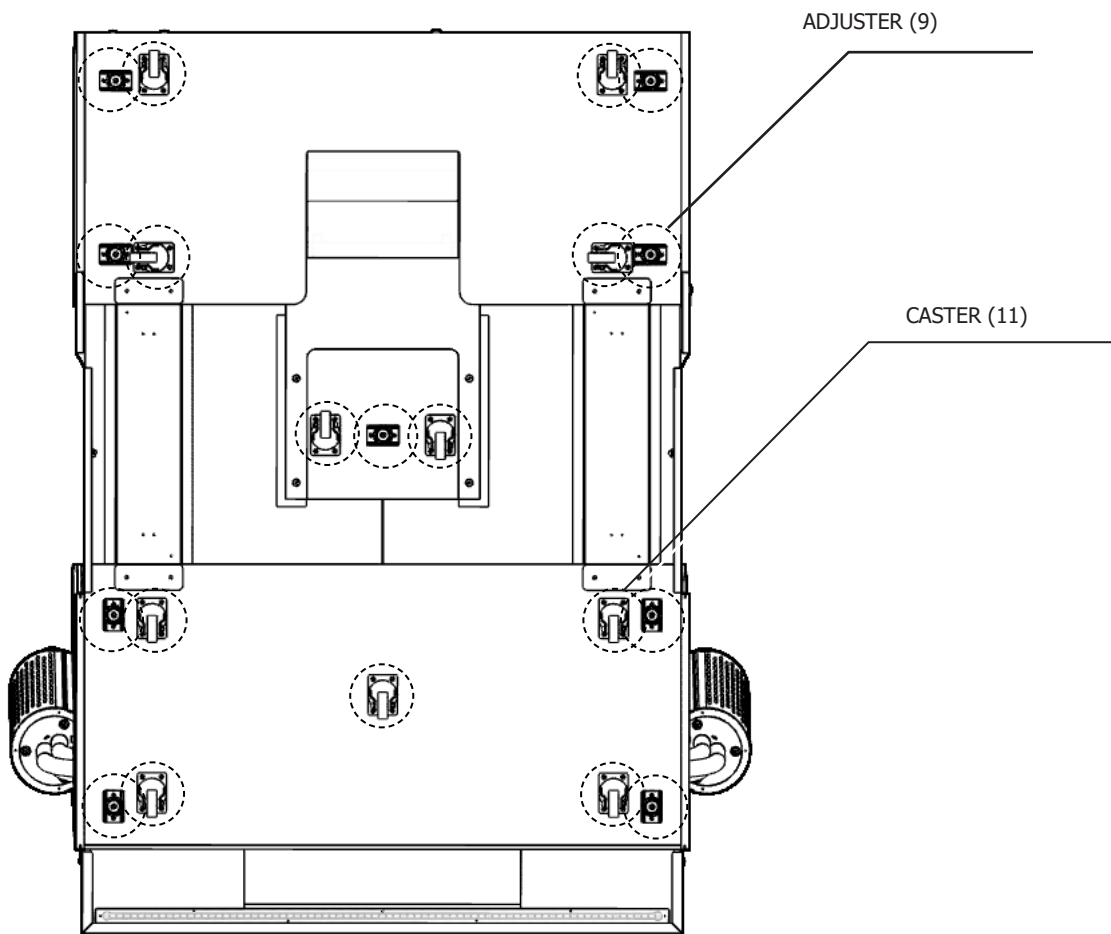

FIG. 6-13a Bottom View

- 1 Move the product to the installation site. If the product is to be installed near a wall, secure enough passage-way space for players to access the seat. You must also secure a 20 cm space between the back wall and the back of the cabinet for ventilation.
- 2 Bring the adjusters into direct contact with the floor. Use a wrench to align the height of the adjusters until the cabinet is perfectly level.
- 3 After setting, turn adjuster nuts upwards to tighten them and secure adjuster heights.

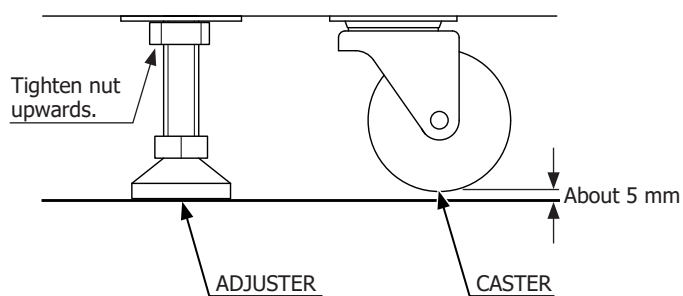
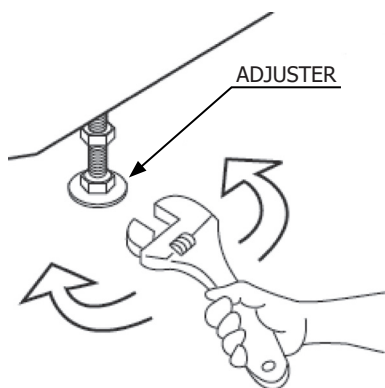

FIG. 6-13b Aligning the Adjusters

You must secure a minimum 20cm ventilation space between the back of the Gun Cabinet and the wall.

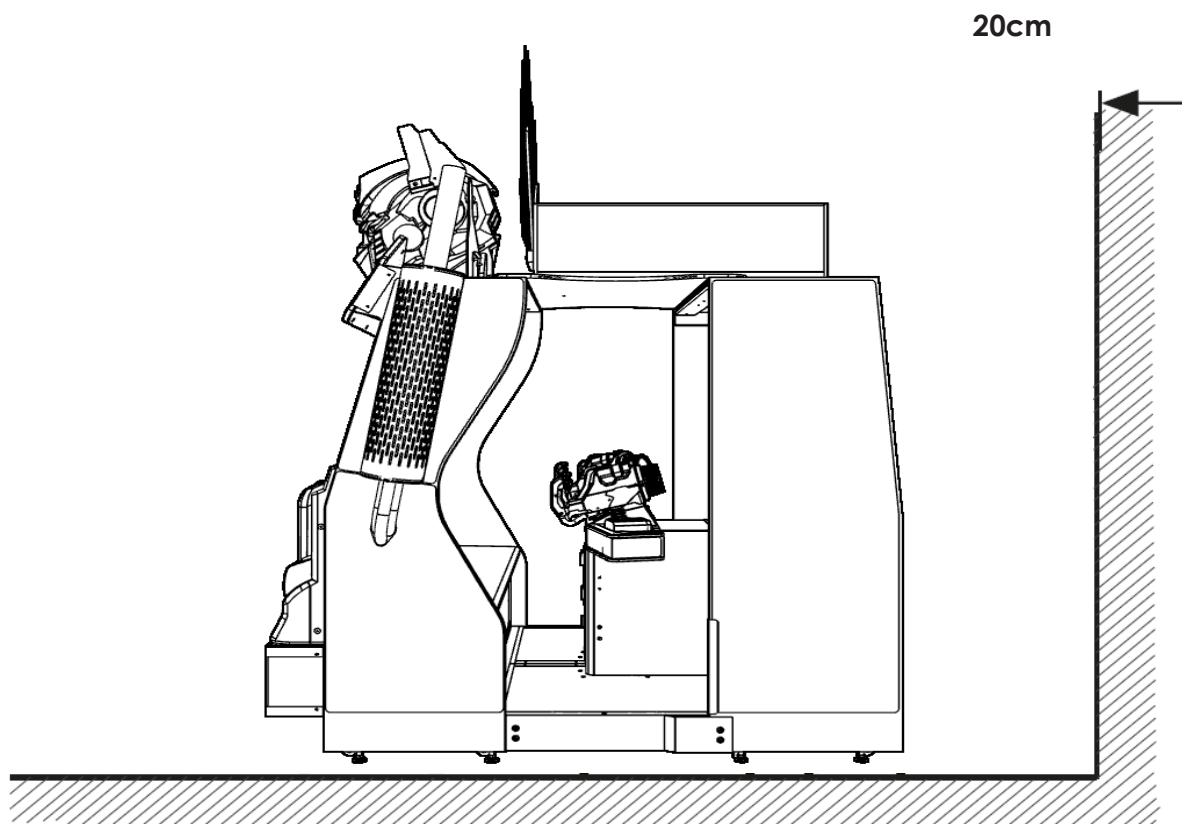

FIG. 6-13c Ventilation Space

6-14 APPLYING “HOW TO PLAY” INSTRUCTIONS

The PLAY INSTRUCTIONS are supplied in several different languages. These are: English (fitted) French, Turkish, Italian, Spanish and Russian.

PLAY INSTRUCTION

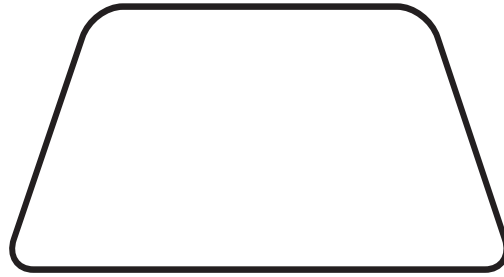

FIG. 6-14a

1 If a language other than English is required for location then the English version which is fitted will need to be removed.

2 The Play Instructions are self adhesive, therefore, it is fairly easy to remove. If removing the Play Instructions prove to be difficult then apply a small amount of heat using a hair dryer to soften the adhesive prior to removal. **DO NOT** under any circumstances use equipment such as a heat gun or paint remover gun as this will damage the artwork and plastic mouldings.

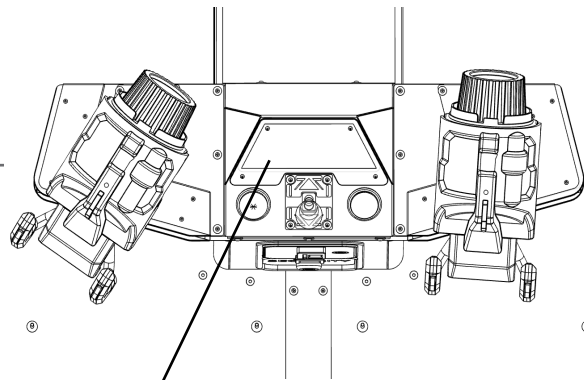

FIG. 6-14b

Play Instruction Panel

6-15 CONNECTING THE DVD DRIVE

PLEASE NOTE THAT THIS PRODUCT IS DESPATCHED WITH SOFTWARE PRE-INSTALLED

WARNING

- When connecting the DVD wire connector, check the orientation carefully and connect securely. The connector must be connected in the proper direction. If it is connected in the wrong direction or indiscriminately at an incline so that a load is applied, the connector or its terminal pins could break, causing a short circuit or fire.
- Be careful not to damage the DVD wire by getting it caught between objects, etc. Doing so may cause a short circuit or fire.
- Connect the DVD DRIVE to the Game BD before connecting the power. Adhere strictly to the proper sequence in performing work. Failing to do so may cause electrical shock or short circuit.

You will need the supplied DVD software kit, board number sticker, and the separately sold DVD DRIVE and DVD wire. To prepare for software installation, you will need to connect the Game BD and DVD DRIVE inside the cabinet using the DVD wire.

The Game BD is the Computer metal case found inside the rear door on the left hand side on the vertical face..

- 1 Remove the (2) M4x25 Truss Screws from the upper corners of the door. Unlock the door using the A444 key (supplied) and place to one side,

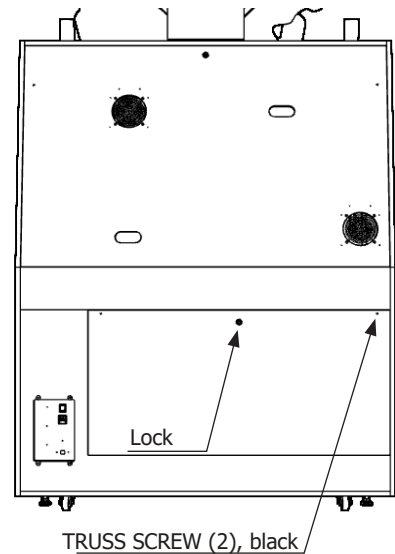

FIG. 6-15a

- 2 The Ring Edge 2 is positioned on the Right Hand side.

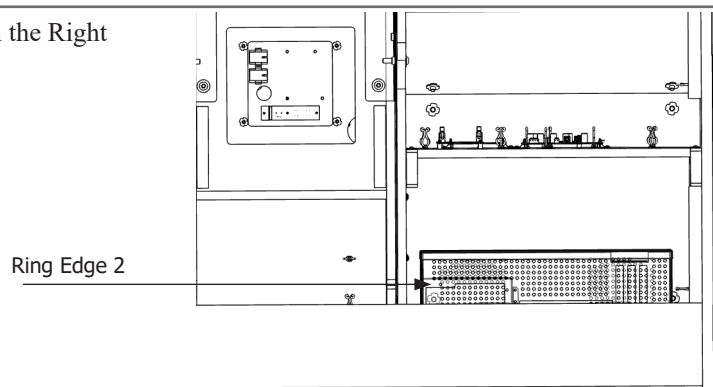

FIG. 6-15b

- 3** Connect the DVD drive USB cable into an unused USB port on the Game Bd.

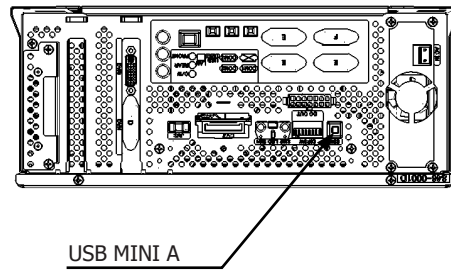

FIG. 6-15c

- 4** Connect the Installation wire into the POWER fly lead within the cabinet

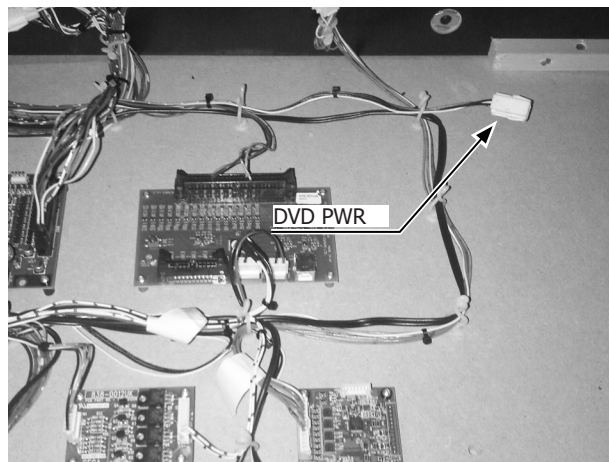

FIG. 6-15d

- 5** On the side of the DVD wire with the “DVD” tag, there are two connectors. Connect them to the DVD DRIVE.

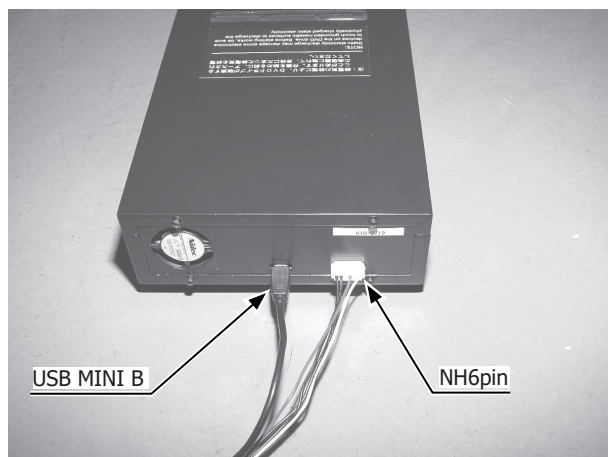

FIG. 6-15e

6-16 CONNECTION OF POWER AND GROUND CABLES

(Only applies where an intergral earth is not present in the mains/power lead.)

WARNING

- Use the power supply equipped with an earth leakage breaker. Use of power supply without such a breaker could result in fire if there is a current leakage.
- Have available a securely grounded indoor ground terminal. Without proper grounding, customers could be electrocuted and product operations might not always be stable.
- Do not expose the power cord or ground wire. If these are exposed, customers could stumble over them, for instance, and easily damage them. Additionally, if these lines are damaged, there could be a risk of electrical shock or short circuit. Set these lines at locations where they will not interfere with customer traffic, or attach covers to them.
- After laying out the power cord on the floor, be sure to always protect it. If the power cord is left exposed, it can easily be damaged, resulting in electrical shock.
- When using the product's AC unit ground terminal, use ground wire with a circular terminal as shown in the illustration, and establish ground securely. Avoid indiscriminant grounding operations such as use of wire with only its sheath peeled off.

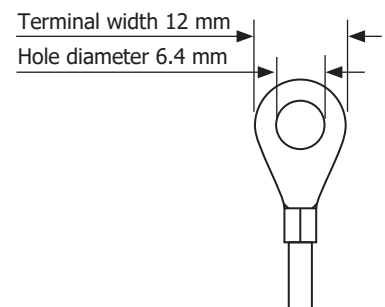

IMPORTANT

If grounding has been established with the ground wire inside the power cord, do not perform grounding with the AC unit ground terminal. Conversely, if the AC unit ground terminal has been used for grounding, do not establish ground with the ground wire in the power cord. Otherwise there could be faulty or erroneous operations.

The AC unit is on the lower back of the DLP. This AC unit contains the following.

- Main switch
- Inlet for power cable connection
- Ground terminal
- Circuit protector

The accessory power cord has a ground wire inside it.

Connect the power cord to the AC unit then insert the power cord plug into a “power outlet with ground terminal.” If there is no “power outlet with ground terminal,” be sure to establish ground by some other means; for example, by connecting the AC unit ground terminal to a ground wire with a ground mechanism prepared separately. If you use a conversion adapter sold on the market to supply power, connect the ground wire terminal of the adapter to a “securely grounded ground terminal.” <For Taiwan>

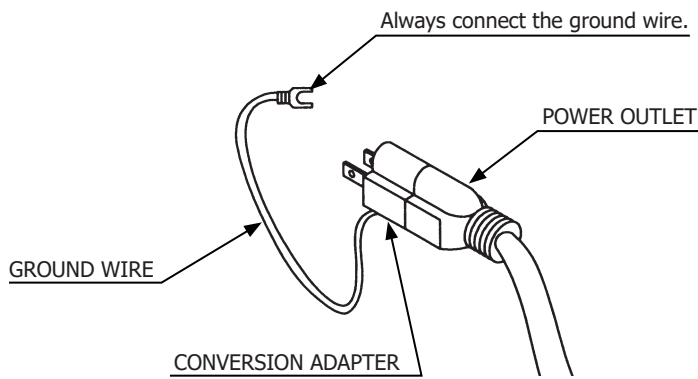

FIG. 6-16a <For Taiwan>

1 Confirm that the main switch is at OFF.

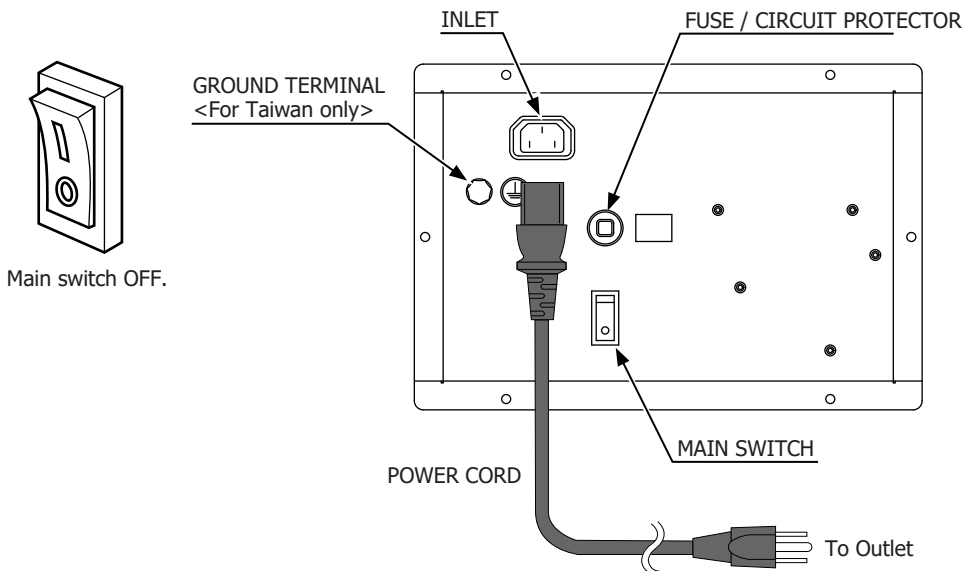

FIG. 6-16b AC Unit

2 Fully insert the power cord connector on the side opposite the power plug into the AC unit inlet.

3 Fully insert the power cord plug into the outlet.

4 When using a ground wire made available separately, connect one end of the wire to the AC unit ground terminal and the opposite end to an indoor ground terminal. The AC unit ground terminal is a bolt-and-nut combination. Remove the nut and pass the bolt through the ground terminal, then secure the nut to the bolt. <For Taiwan>

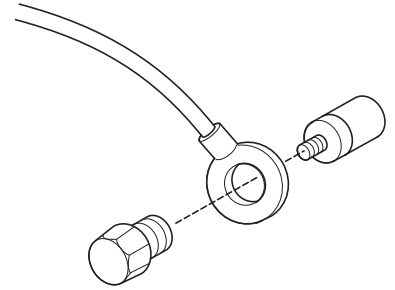

FIG. 6-16c

5 The power cord is laid out indoors. Protect the power cord by attaching wire cover to it. If ground will be established with a ground wire made available separately, lay out the ground wire indoors and have it protected. <For Taiwan>

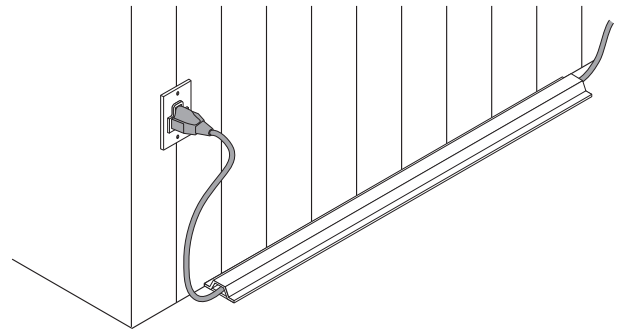

FIG. 6-16d

6-17 ENGAGING POWER SUPPLY (SOFTWARE INSTALLATION)

WARNING

- Be careful not to damage the DVD wire by getting it caught between objects, etc. Doing so may cause a short circuit or fire.
- The following explanation assumes that the product has been assembled properly as explained above. If there is an error or if the product operates in a manner other than as indicated below, cut off the power supply immediately. Failure to do so may result in a fire or electrical shock.
- If you look directly at the laser beam in the DVD DRIVE, you could suffer vision impairment. Do not look inside the DVD DRIVE.

IMPORTANT

- The software is not installed on the game board when the power supply is engaged, so the “Error 22” message is not a malfunction. However, if there is another error display, or if there is no video output at all, there might have been an error in product assembly, wiring connections might be faulty, or the Game BD might not be functioning properly.
- After the power supply is engaged, wait for “Error 22” message to be displayed. If the product is indiscriminately operated in any way beforehand, there could be unexpected problems or malfunctions, as well as damage to parts.
- Once “Error 22” is displayed, set the DVD-ROM in the DVD DRIVE and re-engage the power supply. Installation takes place.
- After the power supply is engaged, the DVD DRIVE tray will not come out for about 30 seconds even if you press the switch. This is due to DVD DRIVE initialization.
- The DVD DRIVE tray can come out or return only while the power supply is engaged. The tray cannot be opened or closed while the power is off.
- Even after the software has been installed, store the DVD software kit, DVD DRIVE and DVD wire in a secure location.
- If for any reason installation cannot be completed, an error is displayed. Refer to the service manual and take corrective action.

Prepare the supplied DVD software kit and the separately sold DVD DRIVE and DVD wire. (See Chapter 5.)

- 1** Before supplying the power, you must make sure the DVD wire is not pinched or trapped.
- 2** Turn the main switch of the AC unit to ON and engage the power supply.
- 3** The Game BD start-up screen appears. Wait for at least one minute. The error state is established. Check to be sure it is “Error 22.” If it is “Error 22,” proceed to the next operation. If it is not “Error 22,” refer to the Game BD Service Manual and take corrective action.

- 4** Take out 1 urea (plastic head) screw and remove the DVD DRIVE case lid.

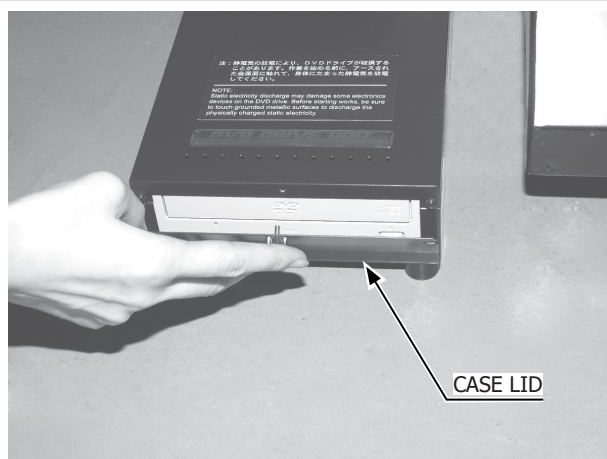

FIG. 6-17a

- 5** Press the DVD DRIVE switch and the DVD DRIVE tray will come out. Set the DVD from the DVD software kit into the tray. Always have the labeled side facing upward.

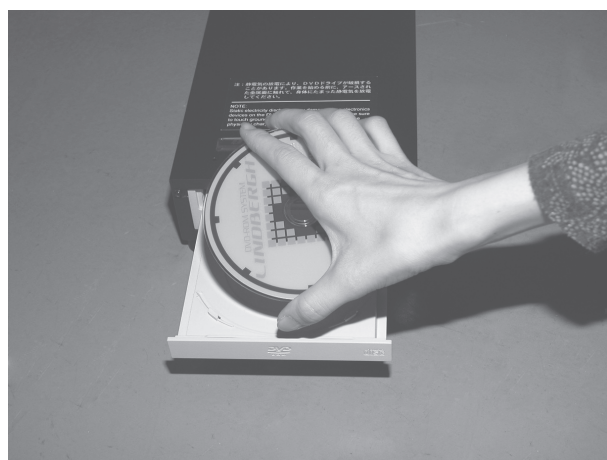

FIG. 6-17b

- 6** Press the DVD DRIVE switch. The tray goes back into the drive.
- 7** Re-engage the power. Turn the main switch to OFF once, wait for at least one minute, then turn the switch back to ON.
- 8** Software is installed automatically from the DVD to the RING EDGE 2. In some cases, it may take about 5 minutes to install software to the Game BD.
- 9** Initialization is completed when the Attract Mode screen appears.
- 10** Press the DVD DRIVE switch so that the tray comes out. Remove the DVD.
- 11** Press the DVD DRIVE switch so that the tray goes back into the unit. If the power is cut off, the tray will not move.
- 12** Set the main switch to OFF.
- 13** Remove the DVD wire from the DVD DRIVE.

14 Attach the DVD DRIVE case lid and fasten it with 1 urea screw.

15 Unlock and remove front door PCB.

16 Remove the DVD wire from the Game BD. Leave the key chip inserted.

17 Attach the outlet plate to front door PCB. Fasten with 2 truss screws.

18 Attach and lock front door PCB.

19 Store the DVD DRIVE, DVD wire and DVD software kit in a location free of dust and cigarette smoke.

Process for Turning on the Power

Set the main switch of the AC unit to ON and engage the power.

When you turn on the power, the attract lighting in the rear window and below the main moulding of the Main Cabinet will come on.

After the start up screen is displayed on the LCD screen, the Advertise (Attract) Mode will start.

During Attract Mode, demo footage and how to play the game will be displayed on the screen.

Sound will be emitted from the left and right front and rear speakers inside the Main Cabinet and the speaker in the center of the seat cabinet.

If the unit is set for no sound during Attract Mode, there is no sound output.

If there are enough credits to enable play, the start button flashes. It goes out if there are no credits during Attract Mode.

Even when the power source has been cut off, credit count and ranking data are kept stored in the product. However, fractional coin counts (inserted coins that do not amount to one credit) and bonus adder counts are not kept.

6-18 CONFIRMATION OF INSTALLATION

Use test mode to confirm that assembly is proper, and that the Game BD, connecting boards, and input/output devices are normal.

Perform the following tests in test mode.

For tests (1) to (7), refer to the TEST AND DISPLAY DATA within this Manual.

1 Information Display Screen

When “SYSTEM INFORMATION,” “STORAGE INFORMATION,” or “JVS TEST” has been selected on the system test mode menu, system information, game information and information on JVS I/O board connected to the Game BD are displayed.

If each category of information is displayed without anomalies, the Game BD is normal.

2 JVS Input Test Screen

When “INPUT TEST” has been selected on the JVS test screen, data input to the JVS I/O board is displayed. On the product, this is the screen for the testing coin switch.

Insert a coin. If the display to the side of the switch changes, the switch and wiring connections are normal.

3 Monitor Test Screen

When “MONITOR TEST” has been selected on the system test mode menu, the screen for checking monitor adjustment status appears.

Projector adjustment is completed when the product is shipped from the factory, but you should observe the test screen to determine whether further adjustment is necessary. Refer to Chapter 10 and adjust the monitor if necessary.

4 Speaker Test Screen

When “SPEAKER TEST” has been selected on the system test mode menu, the screen for checking speaker sound output appears.

To confirm that audio output is normal, have test sound output from the game unit’s speaker.

5 Input Test

When “INPUT TEST” has been selected on the game test mode menu, the screen for testing input device appears. Test operate the input device by pressing each switch. If the display on the side of each input device changes to “ON” and numerical values change smoothly in accordance with each operation, the input device and its wiring connections are normal. (See 9-3a.)

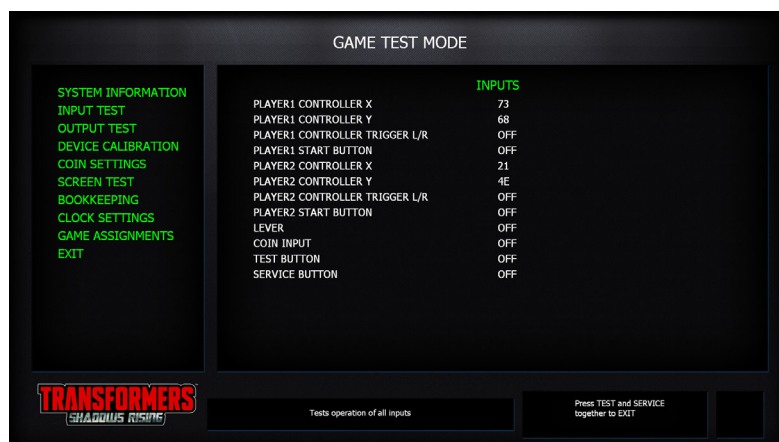

FIG. 6-18a INPUT TEST Screen

6 Output Test

When “OUTPUT TEST” has been selected on the game test mode menu, the screen for testing lamps and other output devices appears. If each output device operates properly, the output device and its wiring connections are normal (see 9-3b).



FIG. 6-18b OUTPUT TEST Screen

7 Calibration

Confirm that the operability of control unit do not present any hindrances to play. Calibration is adjusted when the product is shipped from the factory but it might need to be adjusted again because of vibrations during transport, etc.

If such things as operability are not satisfactory, select “GUN CALIBRATION” on the game test mode menu and check and adjust settings. (See 9-3c.)



FIG. 6-18c GUN CALIBRATION Screen

Conduct these tests when performing routine checks each month.

7 PRECAUTIONS WHEN MOVING

7-1 MOVING THE MACHINE

WARNING

- Always disconnect the power cable before moving the product. If it is moved with the power cable connected, the cable could be damaged, causing fire or electric shock.
- To move the unit over the floor, pull in the adjusters and have the casters contact the floor. While moving the unit, be careful that the casters do not roll over the power cord or the ground wire. If cord or wire is damaged, there could be electrical shocks and/or short circuits.
- When crossing a sloped or stepped area, disconnect the Monitor Cabinet and Rear Cabinet. If you tilt them while connected together, the connection points may be damaged and personnel could be injured.
- When lifting the cabinet up steps, you must hold it by the designated handles or by the bottom surface. Lifting it by any other area may lead to damage or disfiguration to that part or surrounding parts due to the weight of the cabinet and could also lead to injury of personnel.
- When tilting the cabinet to move it across a sloped or stepped area, always use at least two people. Attempting such an operation alone can lead to accident or injury.
- When moving the components separately, take care concerning the direction you push the Monitor and Rear Cabinet in. These elements may fall over, causing damage or an accident.

CAUTION

- When moving the components, do not push any of the plastic elements or shaped parts and do not use them to pull the components along. This may damage the parts or the surrounding parts and this could lead to accidents or injury.
- After dividing the components to move them, do not use the Control Units in the Monitor Cabinet to push or pull the cabinet. This may damage or disfigure these parts and lead to malfunctions or injury.
- When moving the separated components, be sure to push/pull each cabinet lengthways. Trying to move the cabinet any other way may cause the cabinet to topple over.

STOP

IMPORTANT

- When moving the cabinet, do not hold, push, or pull the Control Units. This may disfigure or damage them.
- If you need to move components through a narrow or low door and the only way to get the separated components through is to turn them on their side, or if a separation method other than those described in this manual is required, either make a request to the office listed in this document or the place of purchase to perform the operation or contact them regarding how to perform it. Carelessly turning the components onto their side or separating them in ways other than those depicted in this manual may lead to irreparable damage.
- Do not press the monitor screen. The screen can be easily damaged and cannot be repaired if it is, meaning complete replacement will be necessary.

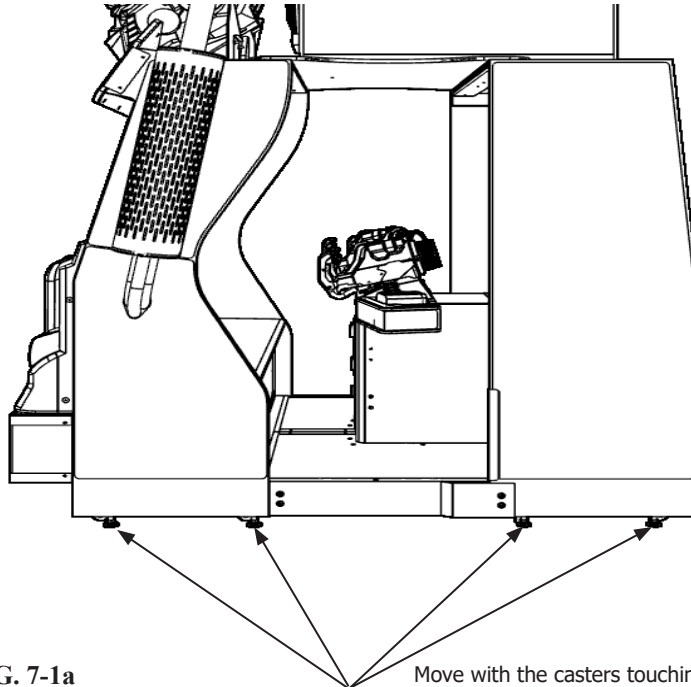

FIG. 7-1a

Move with the casters touching the floor.

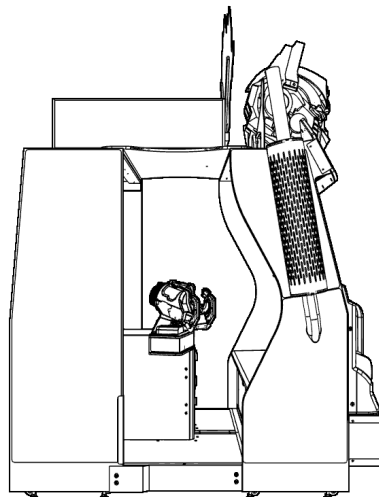

FIG. 7-1b

Separate components when moving over a sloped or stepped area.

7-2 SEPARATING THE MONITOR/SEAT CABINET

⚠ WARNING

- Do not carelessly separate the components of the Monitor Cabinet. This may lead to accidents during maintenance and electric shocks/short circuits during operation.
- After separation of the Monitor Cabinet, the Rear Cabinet is not sufficiently strong. Take care which places you push or pull. Do not turn the components onto their sides. This may lead to disfigurement or damage and could cause accidents during maintenance (possibly leading to irreparable damage).

⚠ CAUTION

- To work safely and precisely, prepare a steady safety stool or ladder to stand on. Climbing onto the cabinet or hanging down from it can lead to accidents.
- Perform the separation operation with at least two people. Performing the operation alone could lead to an accident.

STOP IMPORTANT

If the only way to get the separated components into a desired location is to turn them onto their side, or if a separation method other than those described in this manual is required, contact the office listed in this document or the place of purchase. Turning the components onto their side may disfigure or misalign the cabinet and could lead to irreparable damage.

If an entrance is narrow, follow the process detailed below to separate the Monitor Cabinet and Rear Cabinet.

When the Monitor Cabinet and Rear Cabinet are separated, take due care during all moving operations. Hold the bottom surface as much as possible and move the component slowly.

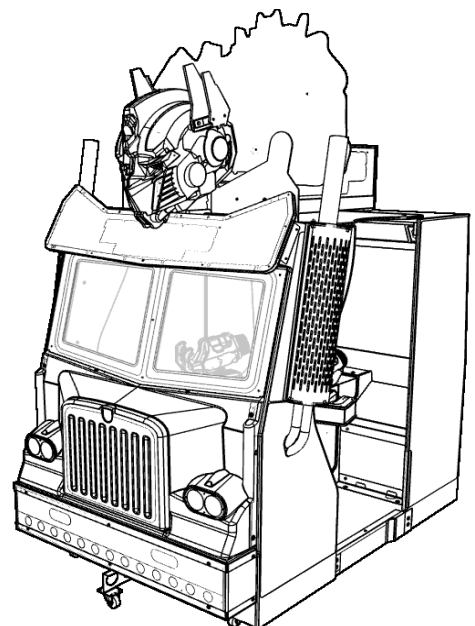

FIG. 7-2a MAIN CABINET

This section of the manual will reference steps that are detailed in parts of Section 6. Please refer to the appropriate section and perform the instructions in reverse in order to safely remove parts so the cabinet can be moved.

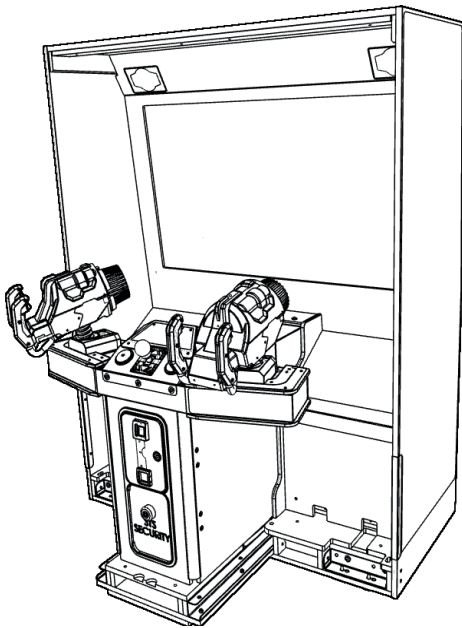

FIG. 7-2b MONITOR CABINET

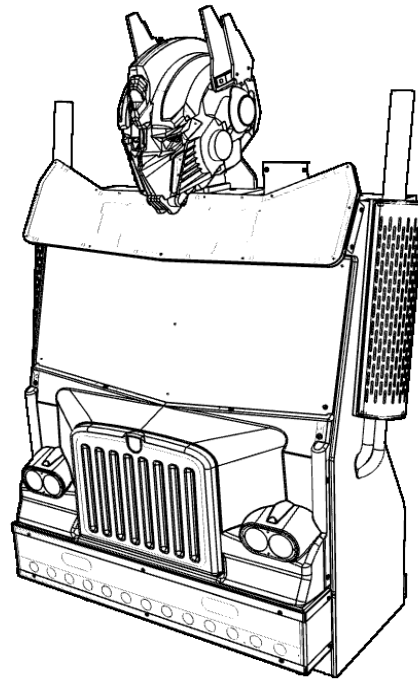
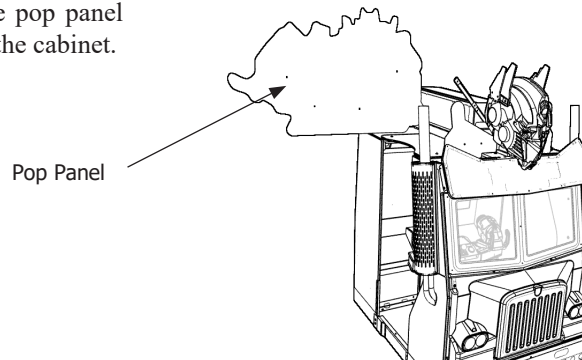
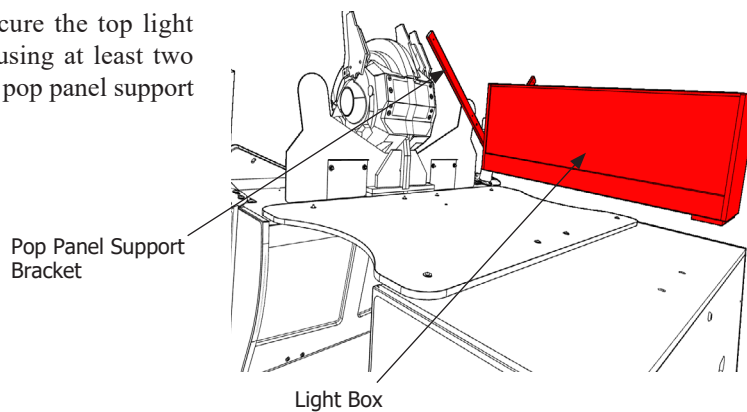

FIG. 7-2c REAR CABINET

- 1 Remove the (4) M6 fixings that secure the pop panel and remove the pop panel from the roof of the cabinet.



- 2 Remove the (3) M8 fixings that secure the top light box (as detailed in Section 6) and using at least two people, remove the top light box and pop panel support bracket safely from cabinet roof.



- 3** Remove the (8) M8 fixings that secure the roof panel to both sections of the cabinet and remove the roof panel.

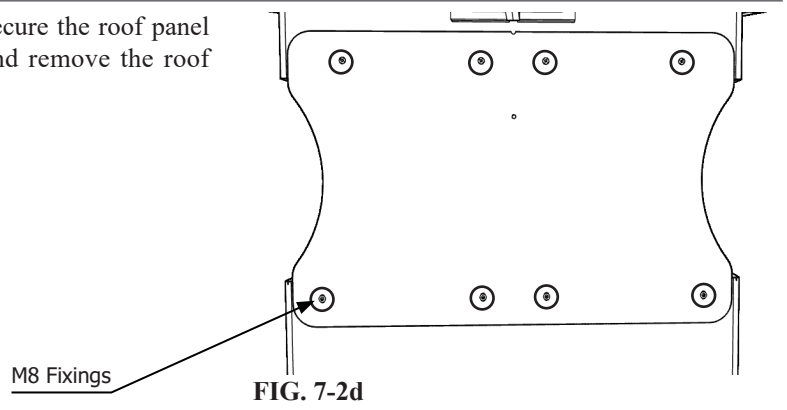

- 4** Remove the SIDE SASH brackets from both the left and right hand sides.

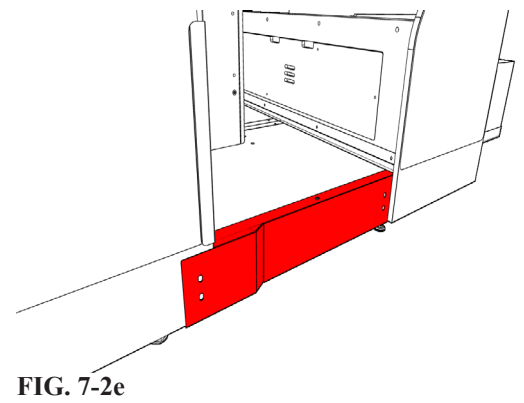

- 5** Remove the MID SASH bracket connecting the two floor panels.

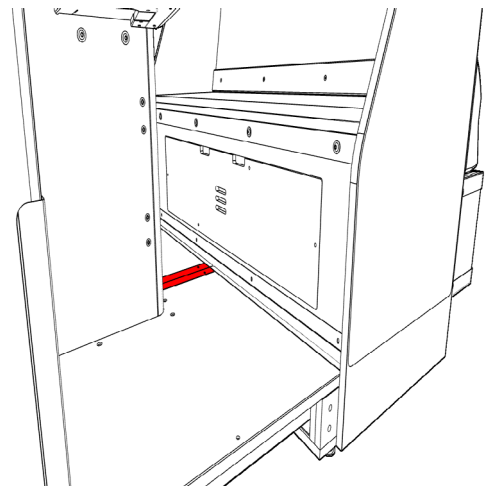

- 6** Remove the REAR SASH bracket from the seat on the REAR CABINET.

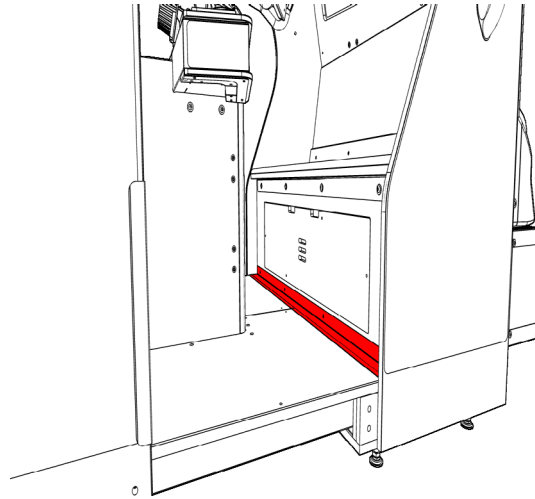

FIG. 7-2g

- 7** Remove the BRACKET FRONT JOINT TOP on both the left and right hand side.

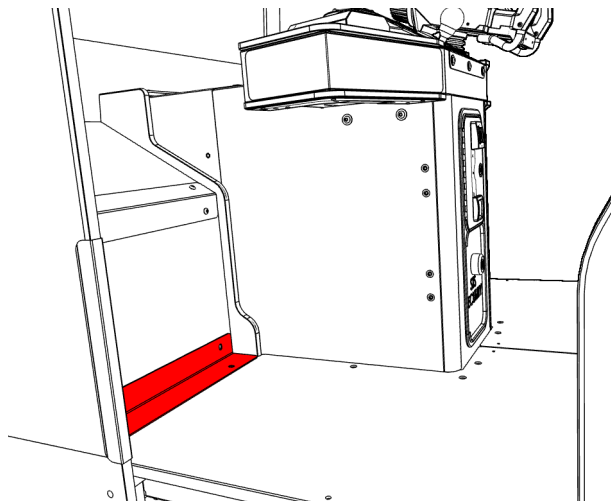

FIG. 7-2h

- 8** Remove both the left and right FLOOR PANELS. Disconnect the harnessing between the REAR and MONITOR CABINET.

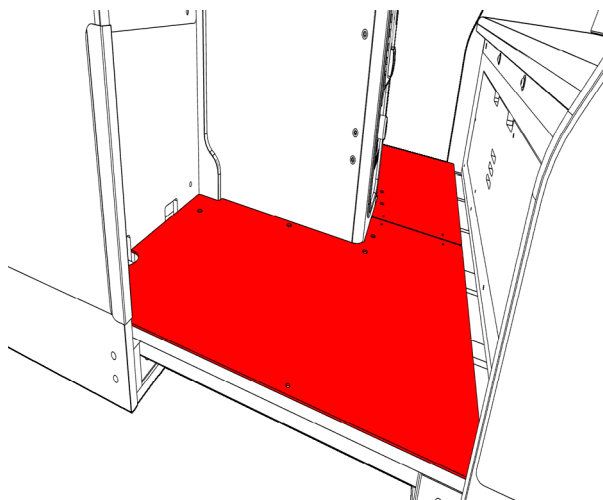
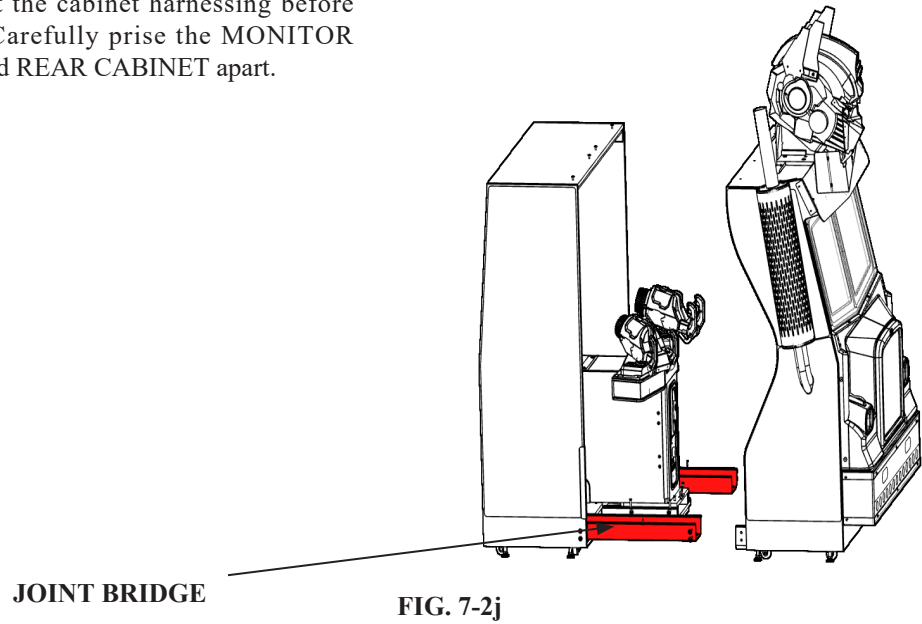

FIG. 7-2i

- 9 Disconnect the JOINT BRIDGE on both the left and right hand side from the REAR CABINET. Be sure to disconnect the cabinet harnessing before separating. Carefully prise the MONITOR CABINET and REAR CABINET apart.



- 10 To reassemble, follow these steps in reverse order. Also refer to the Installation Guide within Section 6 of this manual. If the MONITOR CABINET is still too wide, remove the JOINT BRIDGE brackets and compress the gun cabinet (see Section 6 for details on how to compress/extend the gun cabinet).

8 GAME DESCRIPTION

After the coins are inserted, available credits will display at the bottom of the screen. After required coins are inserted, the text will change from “PLEASE INSERT COINS” into “PRESS START BUTTON”. The start button on the cabinet will then be flashing.

Coin system can accumulate up to 24 credits. Credits beyond 24 will not be counted and returned to player, but will be recorded by system internal counter.

Based on the difference of test mode settings, “INSERT COIN(S)”/“INSERT MORE COIN(S)” may change to “SWIPE CARD TO PLAY”.

The player’s role is based on which side the “START” button is pressed. Press “START” button once to start the game. If you choose the left side, you will be Player1, and the right side will be Player2.

Game screen

Player1 and Player2’s life gauge, score, available Energon Cubes, combo and weapon will be displayed on the left side of the screen for Player1 and right side of screen for Player2. The available credits and subtitles will be displayed on the bottom of the screen. Achievements are displayed in the upper centre of the screen.



FIG. 8a

Basic control

The player will encounter various enemies throughout the game. Enemies that are actively attacking the player will be outlined.



FIG. 8b

Use the controller to aim at the enemies. You must shoot at the enemies before they shoot you.



FIG. 8c

Points are awarded when enemies are destroyed.

The enemy will attack if the player does not destroy it in time. Each time a player is shot, the player's life gauge will decrease. If the player's life gauge is depleted, the game is over (with the option to continue).



FIG. 8d

Energon

Energon is special Transformer Hyperenergy that can be found in specific places in levels and received from defeating glowing enemies. The player can use an Energon cube in a defensive way by pulling the lever down or in an offensive way by pushing the level up. The player can store up to 4 Energon cubes at once.



FIG. 8e

Pulling the lever down when the Player has an Energon Cube will shield the player from damage for a limited time.

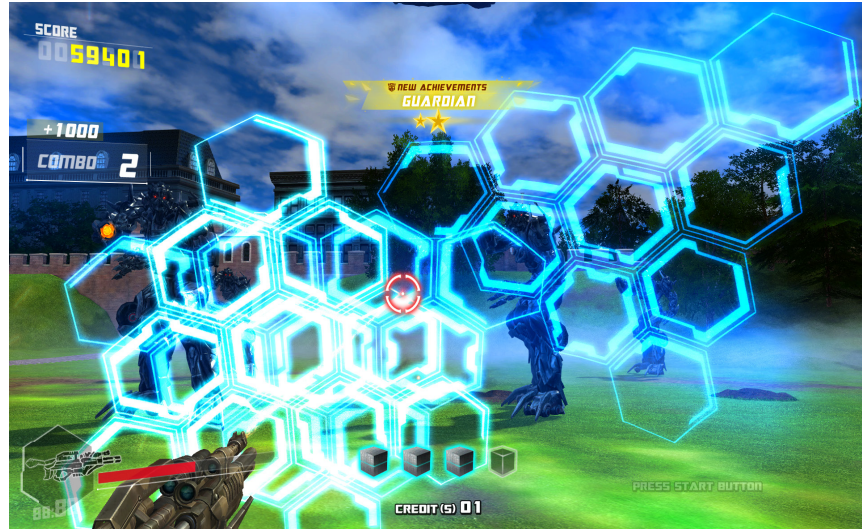

FIG. 8f

Pushing the lever up when the Player has an Energon Cube will destroy all enemies on screen



FIG. 8g

Weapon Power Ups

Levels also contain special power ups that give the player more powerful weapons. They can be shot to be collected and used.



FIG. 8h

Weapon Pickup

Weapon pickups will only last for a limited time. This is shown in the bottom left hand corner of the screen and the player will also hear a countdown noise to inform them when a weapon power up is about to expire.

Weapon usage timer



FIG. 8i

Example of Weapon Pickup (RPG)

Co Op Battle

As the player progresses through the game, they will fight together with Autobots against a few special enemies. These enemies will have attack markers on their body.



FIG. 8j

If the player(s) can clear all the attack markers before they disappear, the player(s) will be rewarded extra bonuses.



FIG. 8k

If the player(s) are unable to clear all the attack markers before they disappear, the players will be attacked and the corresponding life gauge(s) will decrease.



FIG. 8l

Results are determined by how quickly players can damage each marker.



FIG. 8m

Based on players' performances in Co-op Battle, the final result screen will be displayed.



FIG. 8n

Action Sequence Controls

As the player progresses through the game they will encounter a series of mini games called “ACTION SEQUENCE CONTROLS”



FIG. 8o

Players will be required to interact by pushing the lever up or down when the icon passes over the corresponding symbol.



FIG. 8p

Action Button Sequences can also occur where the player(s) need to press their Start Button as fast as possible to fill up the circle.



FIG. 8q

If the players succeed in these actions, they can avoid the attack and gain bonus score.



FIG. 8r

If the players fails in these actions, the life gauge will be decreased.



FIG. 8s

Boss Battle

At the end of each level, there will be a BOSS to fight against. Like in Co-op Battle, there will be attack markers on these BOSSES.



FIG. 8t

Shoot at the attack markers before they disappear to deplete the BOSS' life gauge. When the BOSS life gauge is depleted, it is defeated.

BOSS HEALTH GAUGE



FIG. 8u

Bonus Markers appear on BOSS enemies that can be destroyed for bonus points



FIG. 8v

BONUS DAMAGE MARKER

Stage & Achievement Results

When each level is cleared, "Stage Result" will be displayed.

In this screen, the surviving player score(s), rank(s) and "Achievements Completed" will be displayed.

"Achievements" are secret challenges within levels awarded for things like destroying specific enemies or taking no damage. The more achievements you complete, the better your rating will be.

In "Stage Result", based on the "Achievements Completed" rating, the player can recover a part of the "life gauge". The higher the percentage completed is, the more "life gauge" will recover.

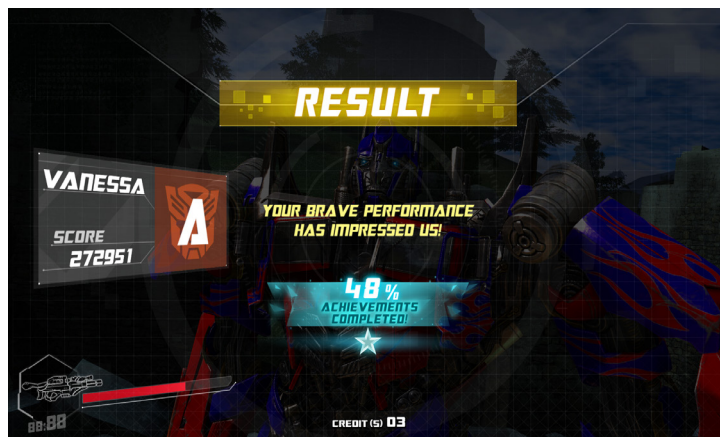

FIG. 8w

HOW TO PLAY

Join The Game

If the player wants to join the game during other player's game, the player can insert coins and press "START" button. If enough credits are reached, the "START" button on the other side of the cabinet will flash, and the player can press it to join the game.

Game Continue

When the player's life gauge is depleted, "Continue Game" screen will appear. Insert enough coins and press "START" button to continue. If enough credits are available, press "START" button directly to join the game.



Game Over

If the player's life gauge is depleted and doesn't continue, when the countdown is 0, game is over.



Name Entry

When the game is completed, if the total score is in the top 10, the player can input their name to display in the game ranking.

Using the Control Unit

Use the control unit to aim at targets and fire. Moving the control unit will move the target sight on the screen. The red target is the 1P side and blue target is the 2P side.

Pull the trigger to fire on the screen. You have unlimited ammunition.

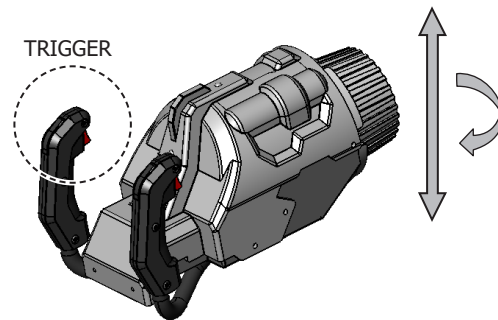

FIG. 8x Control Unit

Game Rules

Once the game starts, the life for the player(s) will be displayed at the bottom corner of the screen (left for player 1 and right for player 2).

- Use the control unit to aim and fire at the oncoming enemies.
- Being hit by enemy attacks will reduce your life.
- It is game over when your life bar fully depletes.



PLAYER 1 LIFE

FIG. 8y

During the game, a player will have to perform various actions. When an action needs to be performed, the action icon will appear on the screen. The action icon indicates the start of an action. Then follow the onscreen instructions.



FIG. 8z

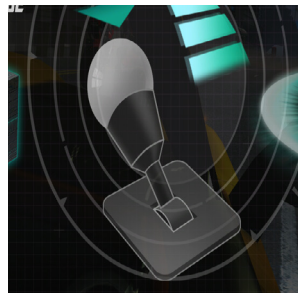

Use the Lever



Press Start Button
□8ab

FIG. 8aa

9 EXPLANATION OF TEST AND DATA DISPLAY

WARNING

Do not touch any parts that are not specified in these directions. Touching unspecified locations may lead to electric shock or cause short circuits.

CAUTION

- Be careful that your finger or hand does not get caught when opening/closing the coin chute door.
- Operating the TEST Button and SERVICE Button during Test Mode may be slightly uncomfortable, due to the position of the buttons in relation to the cabinet seats. Take care not to hurt your shoulder or back, or scratch yourself on any parts of the cabinet.

STOP IMPORTANT

- When you enter the Test Mode, fractional coin and bonus adder data is erased.
- Adjust the sound to the optimum volume, taking into consideration the environmental requirements of the installation location.
- Removing the Coin Meter circuitry renders the game inoperable.
- Have a flashlight on hand and operate in Test Mode very carefully. The cabinet interior is dark and narrow and you could easily make mistakes in operation.

Perform tests and data checks periodically by manipulating the TEST Button and SERVICE Button in the cabinet. Follow the instructions in this chapter to conduct checks when the game machine is first installed, when money is being collected, or when the game machine does not operate properly.

Shown below are the tests and screens to be used for different problems.

For this reason, the product's Test Mode consists of two modes: a System Test Mode for systems in which coin settings, for instance, are made for products that use the same system, and a Game Test Mode for setting of difficulty level, etc., and for input/output test of operational units used exclusively with this product.

9-1 SWITCH UNIT AND COIN METER.

The SWITCH UNIT and COUNTERS are housed within the COINTOWER. To access these controls you will need to open the COIN door. The switches and counters can be found directly on the rear face of the Tower.

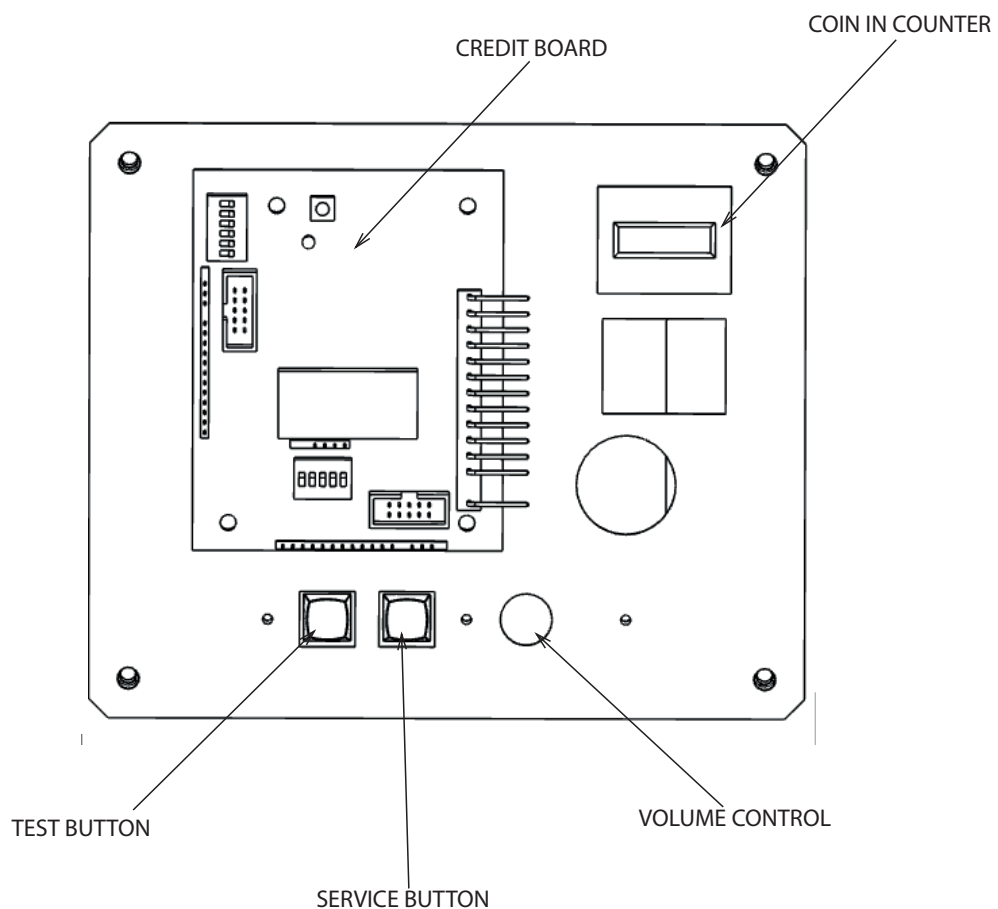

FIG. 9-1a Switch Unit

DEVICE	FUNCTION
TEST BUTTON	Press to enter TEST MODE - Also used to enter choices selected within TEST MODE
SERVICE BUTTON	Press for SERVICE CREDIT - Also used to scroll through TEST MENUS
COIN IN COUNTER	Counts inserted coins (£0.10 or \$0.10 = 1 count)
VOLUME CONTROL	Adjusts audio level

9-2 SYSTEM TEST MODE

STOP IMPORTANT

- The details of changes to Test Mode settings are saved when you exit from Test Mode by selecting EXIT from the system test mode menu. If the power is turned off before that point, changes to the settings will not be saved.
- Use with the specified settings. If settings other than those specified are used, inappropriate operations or malfunction may occur.

In the system test mode, the main activities include checking RING EDGE 2 information and actions and the setting of coin/credit. Also, a screen appears for checking screen adjustments. For details, see the RING EDGE 2 service manual, which is provided separately.

Use the following settings with this product. If the settings are not as specified, error messages might appear and operations might not be normal:

• COIN ASSIGNMENTS

COIN CHUTE TYPE: COMMON
SERVICE TYPE (SERVICE Button Type): COMMON

• NETWORK SETTING

NETWORK TYPE: MAIN
MAIN NETWORK: Setting Not Required.

1 When the TEST Button is pressed, the system test mode menu screen (SYSTEM TEST MODE) appears.

2 Use the SERVICE Button to move the cursor to the desired test item.

3 Press the TEST Button to confirm selection of the item.

4 When testing and checking are completed, select EXIT and press the TEST Button. The SYSTEM TEST MODE screen reappears.

5 When all tests are completed, select EXIT and press the TEST Button. The game screen reappears.

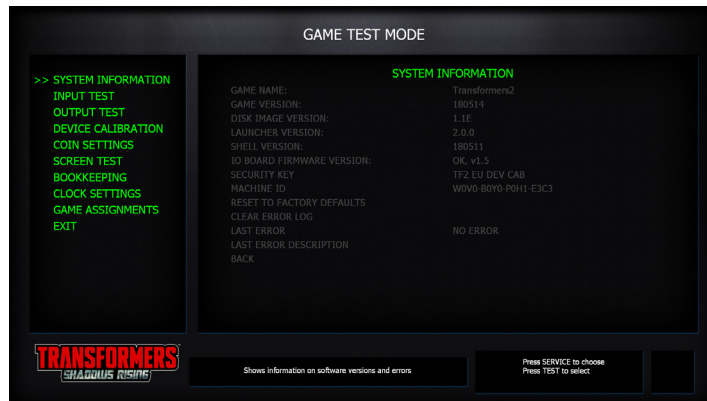

FIG. 9-2 SYSTEM TEST MODE Screen

• Menu Item

SYSTEM INFORMATION	Displays all cabinet and game info
INPUT TEST	Tests each input device used in this game
OUTPUT TEST	Tests each output device used in this game
DEVICE CALIBRATION	Calibrate controller devices
COIN SETTINGS	Adjust coin settings
SCREEN TEST	Adjust screen properties
BOOKKEEPING	Displays cabinet statistics
CLOCK SETTINGS	Adjust cabinet internal clock
GAME ASSIGNMENTS	Adjust game specific settings
EXIT	Exit Sytem Test Menu and return to game

9-3 SYSTEM INFORMATION

System Information

Select 'System Information' from the Test Menu to display the System Information menu. This test displays general system information regarding the hardware configuration and installed software.

<Menu Explanation>



FIG. 9-3a SYSTEM INFORMATION

GAME NAME	Name of installed game
GAME VERSION	Version number of installed game
DISK IMAGE VERSION	Version number for Master Disk Image
LAUNCHER VERSION	Version number for System Launcher
SHELL VERSION	Version number for Shell
I/O BOARD FIRMWARE VERSION	Displays I/O Board Firmware Version
SECURITY KEY	Displays Security Key data
MACHINE ID	Displays Unique Machine ID
RESET TO FACTORY DEFAULTS	If "Test" is pressed when this item is selected then all settings are returned to factory defaults and cabinet will restart (requires confirmation)
LAST ERROR	Displays "Last recorded error" with time and date stamp. Use "Test" button to cycle through last ten errors
LAST ERROR DESCRIPTION	Explains "Last Error" in detail with troubleshooting advice
BACK	Return to System Test Menu

9-4 INPUT TEST

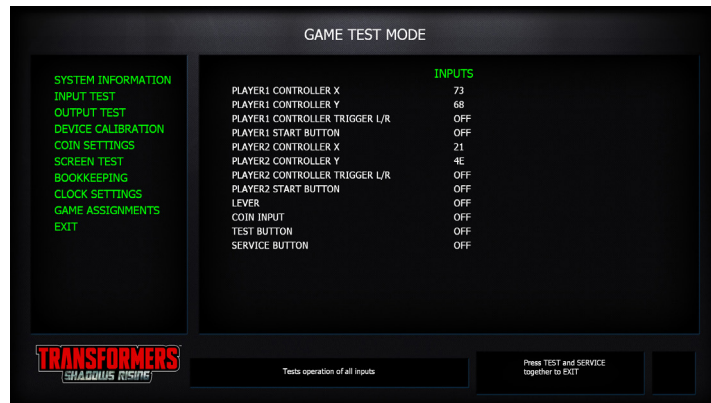

FIG. 9-4a INPUT TEST Screen

The condition of each input device can be checked. Periodically check the condition of each input device on this screen. Conditions are normal if each device operates and yields output as indicated below.

<Operation>

- 1 Press the SERVICE Button and move the cursor to the item (output device) you want to test.
- 2 Whenever the TEST Button is pressed, the display on the right side of the item goes from OFF to ON and the selected output device operates. Confirm that the device operates normally.
- 3 Press the SERVICE Button and move the cursor to EXIT.
- 4 When the TEST Button is pressed, the game test mode menu screen reappears.

<Menu Explanation>

PLAYER1 CONTROLLER X	Move the player 1 controller up, down, left and right and the data (x and y of the controller) varies based on movement.
PLAYER1 CONTROLLER Y	
PLAYER1 CONTROLLER TRIGGER L	Pull the player 1 controller's left trigger, the item will display "ON", release the trigger, the item will display "OFF".
PLAYER1 CONTROLLER TRIGGER R	Pull the player 1 controller's right trigger, the item will display "ON", release the trigger, the item will display "OFF".
PLAYER1 START BUTTON	Press the player 1 START button - the item will show "ON"
PLAYER2 CONTROLLER X	Move the player 2 controller up, down, left and right and the data (x and y of the controller) varies based on movement.
PLAYER2 CONTROLLER Y	
PLAYER2 CONTROLLER TRIGGER L	Pull the player 2 controller's left trigger, the item will display "ON", release the trigger, the item will display "OFF".
PLAYER2 CONTROLLER TRIGGER R	Pull the player 2 controller's right trigger, the item will display "ON", release the trigger, the item will display "OFF".
PLAYER2 START BUTTON	Press the player 2 START button - the item will show "ON"
LEVER	Push the lever up to show "UP". Pull down to show "DOWN"
COIN INPUT	Shows "ON" when a cab receives a coin or credit
SERVICE	Press the SERVICE button - the item will show "ON"
TEST	Press the TEST button - the item will show "ON"

9-5 OUTPUT TEST

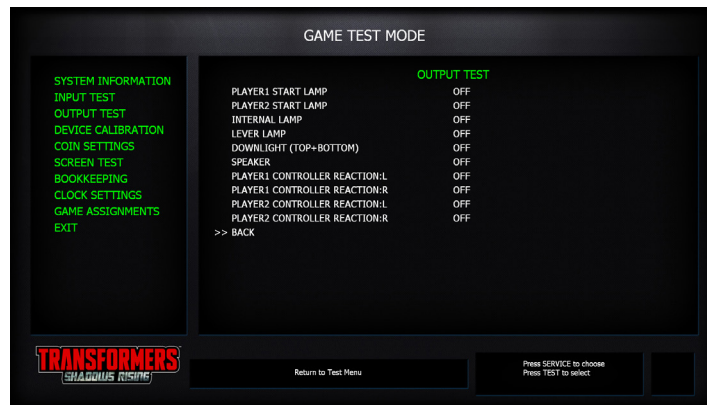

FIG. 9-5a OUTPUT TEST Screen

The condition of each output device can be checked. Periodically check the condition of each output device on this screen. Conditions are normal if each device operates and yields output as indicated below.

<Operation>

- 1 Press the SERVICE Button and move the cursor to the item (output device) you want to test.
- 2 Whenever the TEST Button is pressed, the display on the right side of the item goes from OFF to ON and the selected output device operates. Confirm that the device operates normally.
- 3 Press the SERVICE Button and move the cursor to EXIT.
- 4 When the TEST Button is pressed, the game test mode menu screen reappears.

<Menu Explanation>

PLAYER1 START LAMP	Toggle OFF/ON to illuminate player 1 start lamp.
PLAYER 2 START LAMP	Toggle OFF/ON to illuminate player 2 start lamp.
CONTROLLER LIGHTING	Toggle OFF/ON to illuminate player 1 controller lamp.
LEVER LIGHTING	Toggle OFF/ON to illuminate lever lamp
CABINET ATTRACT	Toggle OFF/ON to illuminate attract lighting
DOWNLIGHT	Toggle Colours to illuminate cabinet downlight
SPEAKER	Toggle OFF/ON to test left and right speaker audio
PLAYER1 CONTROLLER REACTION	Toggle OFF/ON to engage player 1 controller feedback.
PLAYER2 CONTROLLER REACTION	Toggle OFF/ON to engage player 2 controller feedback.

9-6 DEVICE CALIBRATION

STOP IMPORTANT

Calibration is relevant to operability. Manipulate and adjust the control unit with appropriate force. Do not make adjustments with excessive force.

Perform individual calibration of the control units for the 1P side and 2P side.

The current maximum and minimum individual volume values will be reset when entering the Gun Calibration Screen.

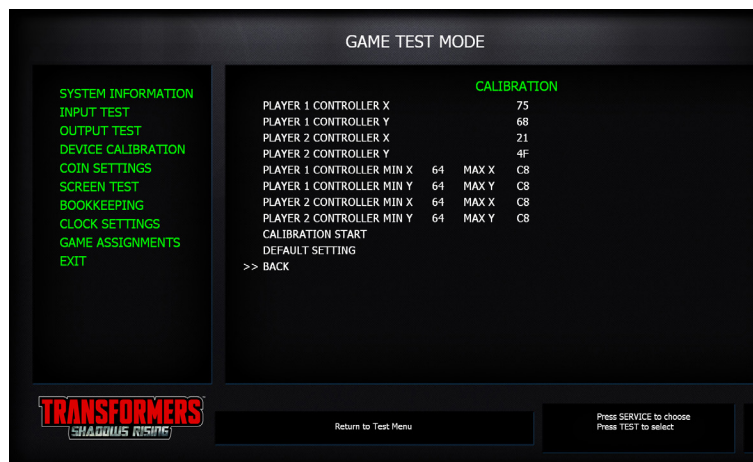

FIG. 9-6a CALIBRATION Screen

<Operation>

- 1 Slowly move the control unit you wish to adjust to each of the four corners of the screen, pulling the trigger at each corner'. The values will set automatically.
- 2 Press the TEST Button and the calibration settings will be altered to reflect all changes made before returning to the GAME TEST Mode screen.

9-7 COIN SETTINGS

This part of the test menu is used to set credit related parameters. Select COIN from the Test menu to display the Coin Settings Menu.

Use the SERVICE button to move the cursor to the desired test item.
Press the TEST button to enter the selected item.

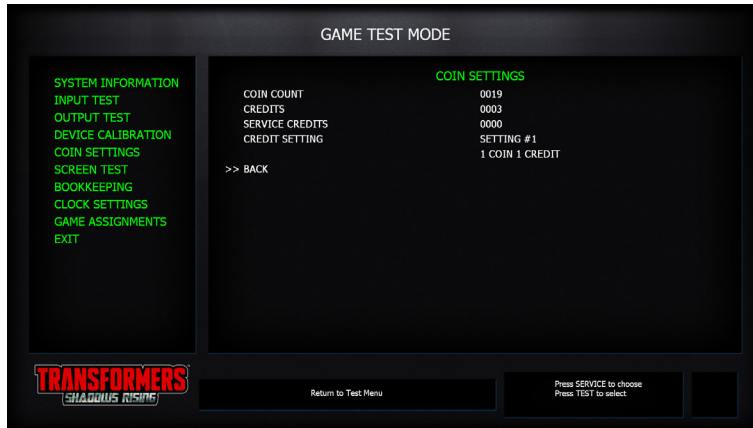

FIG. 9-7a COIN Screen

This text displays the accumulative coins and credits values. Freeplay can be turned on/off by cycling through the Credit Settings options.

COIN COUNT: Coin count value from IO board (cannot be reset)
CREDITS: Total number of credits added to system
SERVICE CREDITS: Total number of Service credits added to system
ENTRY TYPE: Payment Method (COIN*\CARD\ SWIPE)
COIN SETTING: The following coin settings are available:

SETTING #1	1 COIN 1 CREDIT
SETTING #2	2 COINS 1 CREDIT
SETTING #3	3 COINS 1 CREDIT
SETTING #4	4 COINS 1 CREDIT
SETTING #5	5 COINS 1 CREDIT
SETTING #6	1 COIN 2 CREDITS
SETTING #7	1 COIN 3 CREDITS
SETTING #8	1 COIN 4 CREDITS
SETTING #9	1 COIN 5 CREDITS
SETTING #10	FREEPLAY

9-8 SCREEN TEST

Screen

This test is used to test the game display is working correctly.

Use the SERVICE button to move the cursor to the desired test item.

Press the TEST button to enter the selected item.

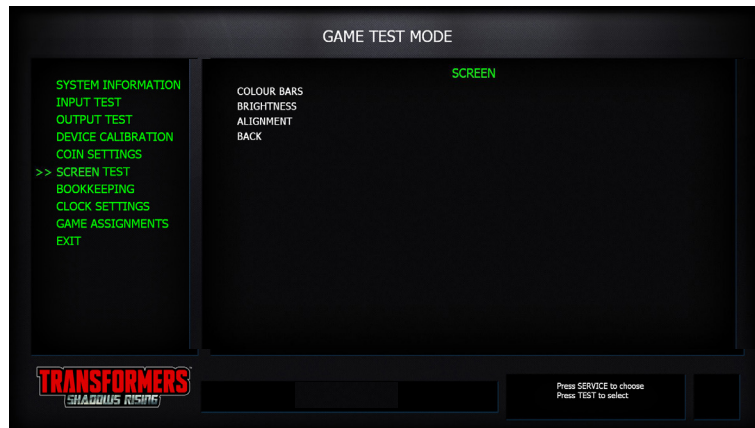
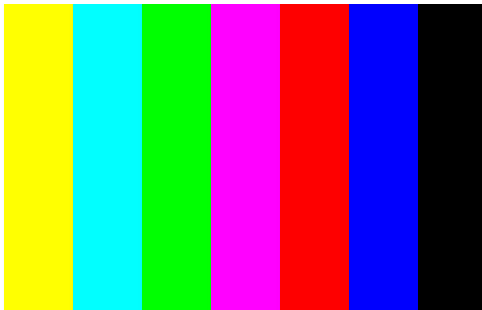

FIG. 9-8a SCREEN TEST

Colour Bars:

Selecting this will display the following screen:



Brightness:

Selecting this will display the following screen:

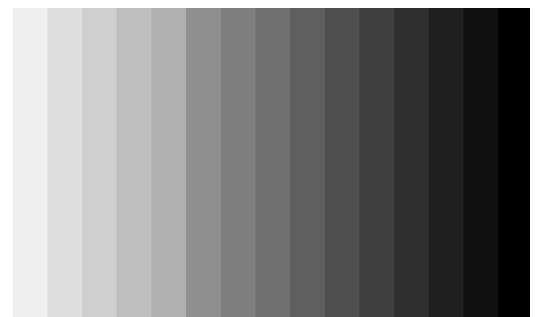

Grid Alignment:

Selecting this will display the following screen:

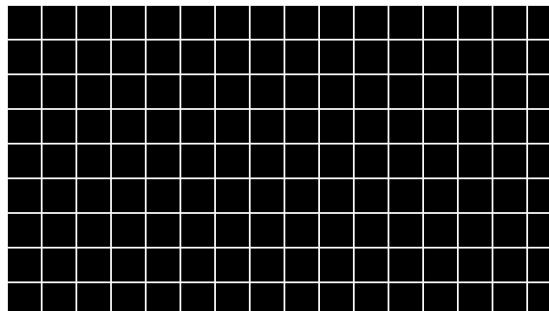

9-9 BOOKKEEPING

Displays bookkeeping information across 3 screens.

Pressing the TEST Button will proceed to the next screen. When the TEST Button is pressed while the (3/3) screen is displayed, the game test mode menu screen reappears.

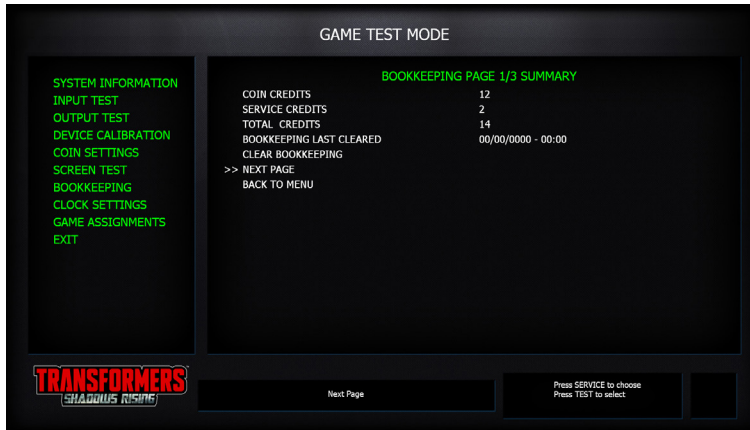

FIG. 9-9aBOOKKEEPING Screen (1/3)

COIN CREDITS:	Number of credits awarded from inserting coins.
SERVICE CREDITS:	Number of credits awarded with the SERVICE Button
TOTAL CREDITS:	Total of COIN CREDITS and SERVICE CREDITS
BK LAST CLEARED:	Last time bookkeeping data was cleared
CLEAR BK:	Clears all bookkeeping data. Action requires confirmation.

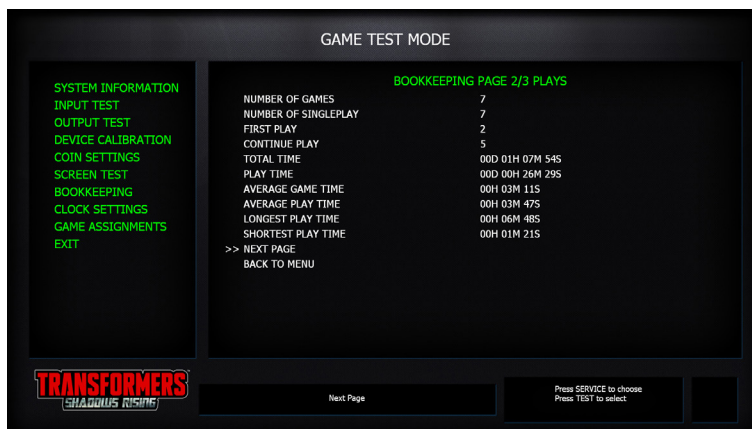

FIG. 9-9b BOOKKEEPING Screen (2/3)

<Menu Explanation>

NUMBER OF GAMES:	Total number of plays on the 1P side and on the 2P side
NUMBER OF SINGLE PLAY:	Total number of single plays on the 1P side and on the 2P side (without another player joining play)
FIRST PLAY:	Total number of first time plays by Player 1 or Player 2
CONTINUE PLAY:	Total number of continues on the 1P side and on the 2P side
TOTAL TIME:	Total time the cabinet has been on
PLAY TIME:	Total play time
AVERAGE GAME TIME:	Average control time for a single game
AVERAGE PLAY TIME:	Average play time for a single game
LONGEST PLAY TIME:	Longest play time for a single game
SHORTEST PLAY TIME:	Shortest play time for a single game

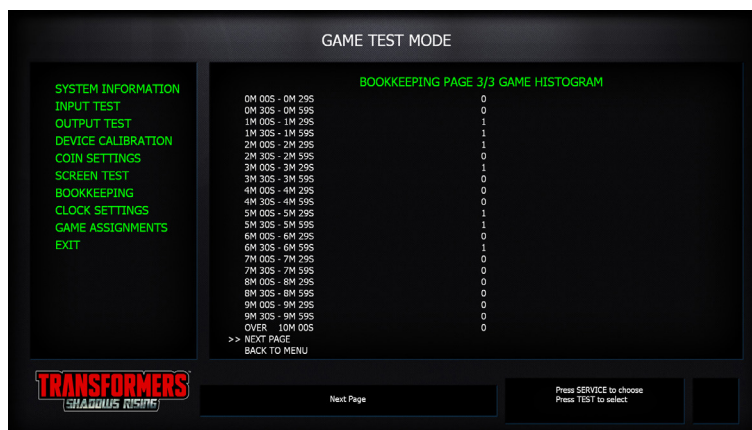

FIG. 9-9c BOOKKEEPING Screen (3/3)

<Menu Explanation>

Play time will be recorded into different lines by 30 second intervals
 All play time over 10 minutes are written into the line OVER 10M 00S

9-10 CLOCK SETTINGS

This test is used to set the current time and date of the computer system. Select 'CLOCK' from the Test Menu to enter the Clock Setting screen. When selected, the screen will show fields for YEAR, MONTH, DATE, HOURS, MINUTES and SECONDS. The SERVICE button is used to select the desired option and the TEST button will increment the value of that option between specified parameters.



FIG. 9-10a CLOCK Screen

Use the SERVICE button to navigate and the TEST button to action changes to the following options. Move the cursor to BACK and press the TEST button to return to the Test Menu.

<Menu Explanation>

CURRENT TIME	Shows current time (24 Hour format)
CURRENT DATE	Shows current date (D/M/Y format)
YEAR	Variable from 2017 to 2070
MONTH	Variable from 01 to 12
DATE	Variable from 1 to 31 (dependant on month)
HOUR	Variable from 1 to 23
MINUTE	Variable from 1 to 59
SECOND	Variable from 1 to 59
BACK	Return to System Test Menu

9-11 GAME ASSIGNMENTS

STOP IMPORTANT

Setting changes do not become effective until EXIT is selected on the setting screen. After a setting has been changed, be sure to always exit the setting screen.

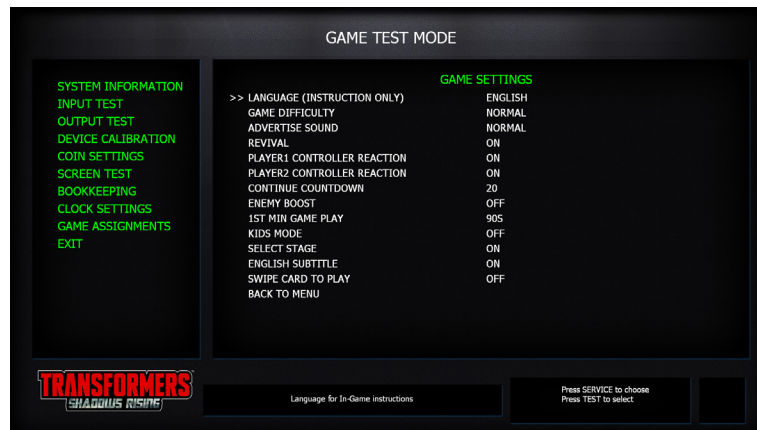

FIG. 9-11a GAME ASSIGNMENTS Screen

The various game settings are established.

<Operation>

- 1 Press the SERVICE Button, move the cursor to the item whose setting is to be changed and select the item.
- 2 When the TEST Button is pressed, the preset value of the selected item changes.
- 3 Press the SERVICE Button and move the cursor to EXIT.
- 4 When the TEST Button is pressed, the game setting screen exits and the game test mode menu screen reappears.

<Menu Explanation> (* denotes default values)

LANGUAGE (INSTRUCTION ONLY)	CYCLES LANGUAGE OF IN-GAME TUTORIALS AND INSTRUCTIONS
GAME DIFFICULTY	DETERMINES GAME DIFFICULTY: VERY EASY, EASY, NORMAL*, HARD, VERY HARD
ADVERTISE SOUND	DETERMINES SOUND LEVEL DURING ATTRACT: NORMAL*, ¾, ½, ¼, OFF
REVIVAL	DETERMINES WHETHER AN ATTACK THAT DEALS DAMAGE TO BOTH PLAYERS CAUSES GAME OVER FOR BOTH PLAYERS: ON* – ONLY ONE OF TWO PLAYERS WILL RECEIVE GAME OVER OFF – BOTH PLAYERS RECEIVE GAME OVER
PLAYER1 CONTROLLER REACTION	DETERMINES WHETHER CONTROLLER HAS SHOOTING REACTION: ON* - SOLENOID IN CONTROLLER PROVIDES REACTION OFF – SOLENOID IN CONTROLLER DOES NOT PROVIDE REACTION
PLAYER2 CONTROLLER REACTION	DETERMINES WHETHER CONTROLLER HAS SHOOTING REACTION: ON* - SOLENOID IN CONTROLLER PROVIDES REACTION OFF – SOLENOID IN CONTROLLER DOES NOT PROVIDE REACTION
CONTINUE COUNTDOWN	DETERMINES LENGTH OF CONTINUE TIMER (IN SECONDS): 10, 20*, 30
ENEMY BOOST	DETERMINES THE AMOUNT OF DAMAGE PLAYERS DO TO ENEMIES: OFF* – NORMAL DAMAGE MID – MEDIUM DAMAGE BOOST HIGH – MAX DAMAGE BOOST
1ST MIN GAME PLAY	DETERMINES TIME LENGTH (IN SECONDS) WHERE PLAYERS CANNOT BE KILLED AFTER ENTERING CREDIT: 90*, 120, 180, OFF
KIDS MODE	DETERMINES WHETHER PLAYER WEAPON IS SHOWN ON SCREEN: OFF* – DISPLAYS GUN ON SCREEN DURING GAME ON – HIDES GUN ON SCREEN DURING GAME
SELECT STAGE	DETERMINES WHETHER PLAYS CAN SELECT WHICH STAGE TO PLAY: ON* - PLAYERS CAN CHOOSE STAGES THEMSELVES OFF – PLAYERS CANNOT SELECT STAGES BETWEEN MISSIONS

ENGLISH SUBTITLE	DETERMINES IF SUBTITLE OF VOICE LINES IS SHOWN
SWIPE CARD TO PLAY	DETERMINES CREDIT TYPE DISPLAY: OFF* – DISPLAYS “INSERT COIN” DURING ATTRACT ON – DISPLAYS “SWIPE CARD TO PLAY” DURING ATTRACT
BACK TO MENU	RETURNS TO TEST MENU

10 VIDEO DISPLAY

CAUTION

The LCD display screen is adjusted prior to leaving the factory. Avoid any unnecessary adjustment.

IMPORTANT

- If the adjustment method in this manual does not resolve the problem, contact the customer service number in this manual or your supplier.
- Do not stick tape, stickers or anything else onto the screen. Any kind of adhesive may damage the surface of the screen.

10-1 GENERAL DESCRIPTION

This specification applies to the 54.6 inch Color TFT-LCD Module P550HVN02.0. This LCD module has a TFT active matrix type liquid crystal panel 1,920x1,080 pixels, and diagonal size of 54.6 inch.

This module supports 1920x1080 mode. Each pixel is divided into Red, Green and Blue sub-pixels or dots which are arranged in vertical stripes. Gray scale or the brightness of the sub-pixel color is determined with a 10-bit gray scale signal for each dot.

The P550HVN02.0 has been designed to apply the 10-bit 2 channel LVDS interface method. It is intended to support displays which have high brightness, wide viewing angle, high color saturation, and high color depth.

* General Information

Items	Specification	Unit	Note
Active Screen Size	54.6	Inch	
Display Area	1209.6(H) x 680.4(V)	mm	
Outline Dimension	1235.6(H) x 706.4(V) x 25.5(D)	mm	1
Driver Element	a-Si TFT active matrix		
Display Colors	10 bit (8bit+FRC), 1073.7M	Colors	
Number of Pixels	1,920x1080	Pixel	
Pixel Pitch	0.21 (H) x 0.63(W)	mm	
Pixel Arrangement	RGB vertical stripe		
Display Operation Mode	Normally Black		
Display Orientation	Landscape/Portrait Enable		
Surface Treatment	AG		Haze = 11%

10-2 CLEANING THE SCREEN

⚠ CAUTION

- Since the LCD display screen is susceptible to damage, pay careful attention to its handling. When cleaning, refrain from using water or volatile chemicals.
- Do not climb onto the control panel. This could lead to injuries, such as bumping your head.
- When reaching across the control panel to clean the screen there is a risk of hurting your shoulder or arm. Use a mop with a non-feathery, soft, dry cloth mop head and wipe the surface of the screen.

When the screen surface becomes dirty, clean it by using a soft cloth such as gauze. When water, and volatile chemicals such as benzene, thinner, etc., spill on the screen surface, it may be subject to damage. Therefore, do not use them.

Also, since the surfaces are susceptible to damage, refrain from rubbing them with a hard material or using a duster. If the screen is especially dirty, call in a professional cleaner.

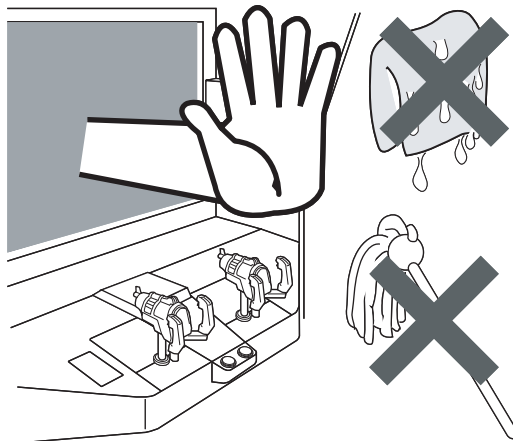

FIG. 10-1

11 CONTROLLER UNIT

WARNING

- When working with the product, be sure to turn the power off. Working with the power on may cause an electric shock or short circuit.
- Be careful not to damage the wires. Damaged wires may cause an electric shock, short circuit or present a risk of fire.
- Do not touch any parts that are not specified in these directions. Touching unspecified locations may lead to electric shock or cause short circuits.
- This work should be performed by site maintenance personnel or other skilled professionals. Work performed by non-technical personnel can cause a severe accident such as an electric shock.
- Exercise due caution in performing soldering procedures. If soldering iron is handled carelessly, there could be fires or burns.
- Proceed very carefully when heating thermal contraction tube. Careless operations can result in fires or burns.

CAUTION

- When fastening plastic parts, be careful not to tighten screws and nuts excessively. Otherwise parts may be damaged, resulting in injuries from fragments, etc.
- Be careful not to get hand or finger caught when removing or attaching the parts.
- Disconnection and connection of connectors will be performed within the narrow cabinet space. Take due care not to scratch or otherwise injure yourself.
- Take care when carrying the removed Control Units. Such heavy lifting carries a risk of injury to back or shoulders.

IMPORTANT

- After the volume has been replaced, be sure to set the volume value on the test mode calibration screen and the input test screen and check variations in the volume value.
- After adjusting or replacing a microswitch, always check ON/OFF of the switch on the input test screen of the test mode.
- Handle parts inside the Control Unit very carefully. Be especially careful to avoid damage, deformation or loss of these parts. If any one of these parts is lost or defective, it can result in damages and/or faulty operations.

If the operability of the Control Unit is unsatisfactory, or if settings on the test mode calibration screen are ineffective, the problem could be a defective mechanism, displacement of the position where volume or microswitch has been fastened, or malfunctioning of volume or microswitch.

Carry out the following procedure to replace Control Unit or microswitch. Also be sure to grease the mechanical components of the Control Unit once every 3 months.

11-1 HOW TO REMOVE CONTROL UNIT

When changing the volume or microswitches in the Control Unit you must first remove the Control Unit. Performing these operations with the Control Unit still attached is difficult and may damage parts or wires.

The following tools are needed for the following procedure.

- Phillips head screwdriver (for M6)
- Wrench or screwdriver for tamperproof screws (for M4)
- A 7 millimeter spanner, hexagonal screwdriver, or socket wrench

Note: this will display the removal of the Controller Unit for the left side (Player 1). The removal of the right Controller Unit (Player 2) is identical in terms of fixing removal.

1 Turn off the power

2 Remove the (3) M4x20 screws which secure the Control Unit to the Control Panel Assy

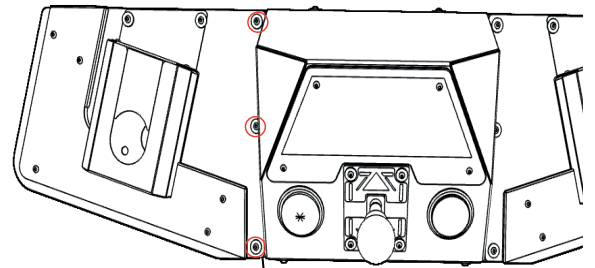

FIG. 11-1a

3 Remove the (5) Internal Hex screw which secure the Control Panel Cover.

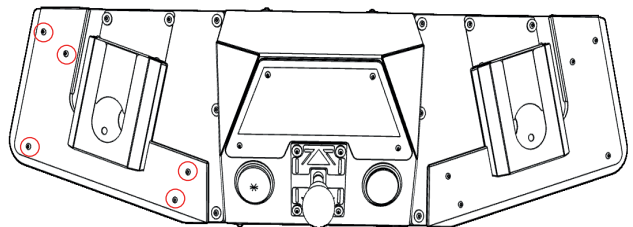

FIG. 11-1b

4 Remove the (4) Internal Hex screw which secure the Control Panel Base Plate.

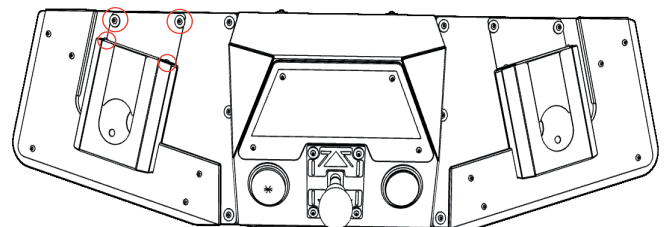

FIG. 11-1c

- 5** Carefully slide the base plate out towards the front of the cabinet.

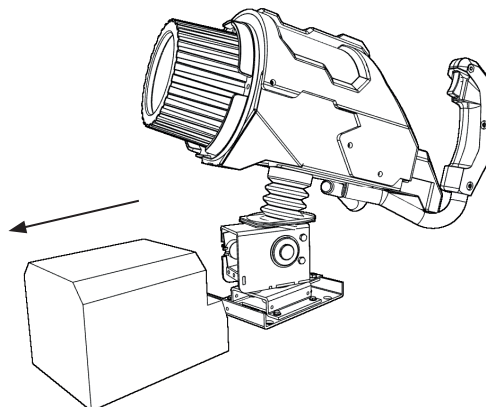

FIG. 11-1d

- 6** Remove the (4) M8 hex bolts from the base of the controller. Disconnect all harnesses.

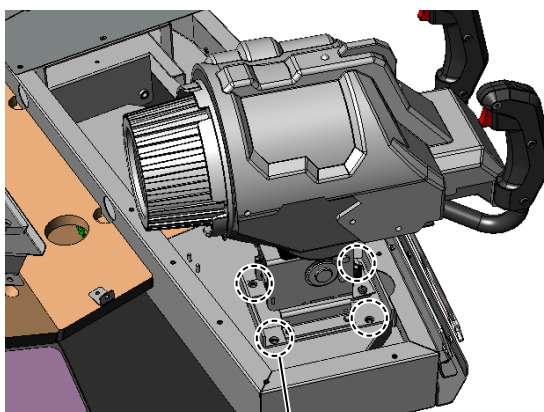

FIG. 11-1e

HEX BLT PAS (4 ea.)
M8x20

- 7** Lift the Control Unit directly upward and remove it. Be sure to feed the harnessing wires through when removing the Control Unit.

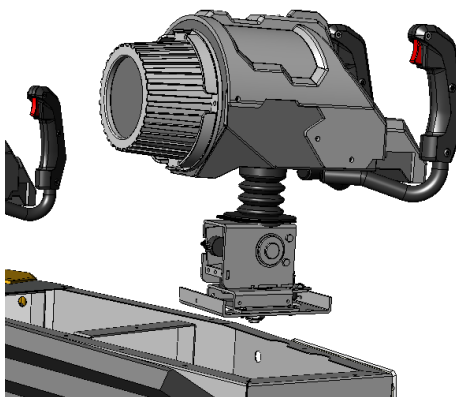

FIG. 11-1f

11-2 ADJUSTING OR REPLACING THE X AXIS VOLUME

STOP IMPORTANT

The volume axis directions when the Control Units are pointed directly at the screen are different.

The X (left and right) axis volume is on the bottom of the Control Unit.

If the X axis volume does not seem to be working properly and the TEST Mode calibration screen has no effect, the cause is likely to be a problem with or damage to the gears of the X axis volume.

When replacing the volume, you will need a replacement volume and three heat shrink tubes. You will also need the following tools and some solder.

- Wrench or screwdriver for tamperproof screws (for M4)
- A 7 millimeter spanner, hexagonal screwdriver, or socket wrench
- An 11-12 millimeter spanner
- Cutters
- Wire stripper
- Soldering iron
- Industrial heat gun

Adjustment

- 1 Turn off the power and remove the Control Unit (see 11-1).
- 2 Locate the X axis volume - positioned at the rear base of the controller.
- 3 Loosen the (2) hex nut from the volume pot bracket.

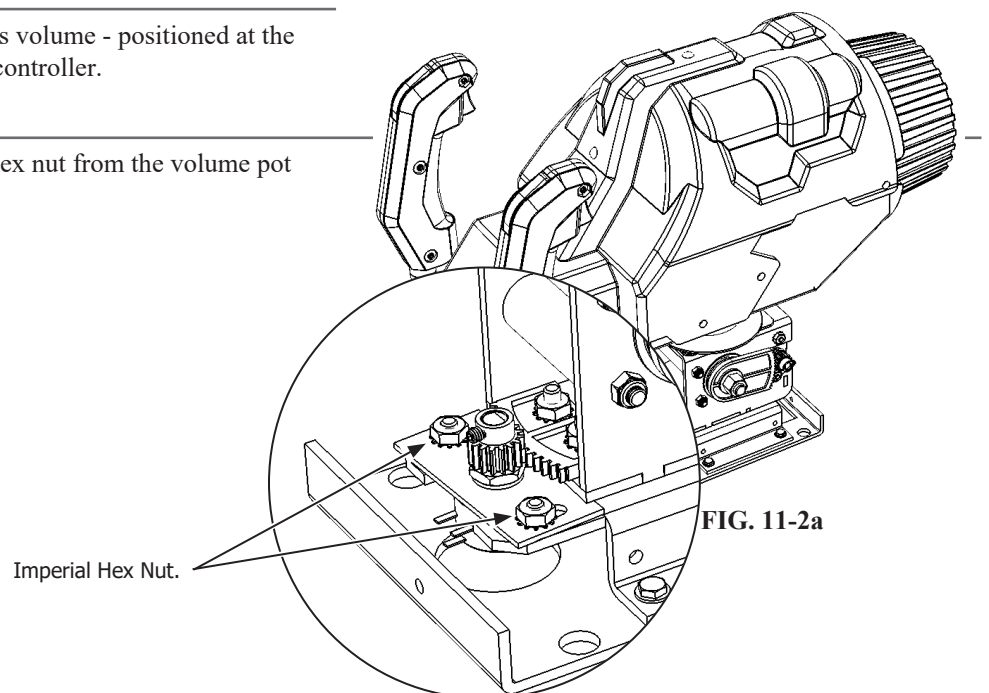

-
- 4** With the Control Unit's pointing to the centre of the screen, make sure that the D-Cut in the Volume pot is positioned as it is in FIG 11-2b

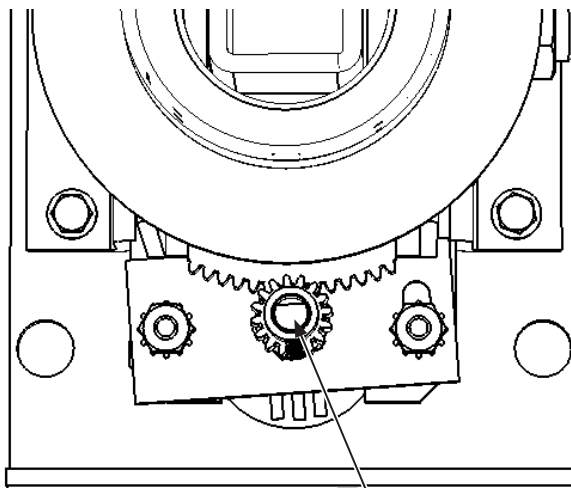

FIG. 11-2b X Axis (Left and Right) Volume

Volume axis D cut face with left and right axis perpendicular to the controller

-
- 5** Tighten the two previously loosened screws.
-
- 6** Move the Control Unit left and right and check that the gears move smoothly.
-
- 7** Reattach the Control Unit, then turn on the power and adjust the volume value on the calibration screen.

Replace

1 Turn off the power and remove the Control Unit (see 11-1).

2 Locate the X axis volume - positioned at the rear base of the controller.

3 Unscrew the (2) hex nut from the volume pot bracket. Disconnect the harness and remove.

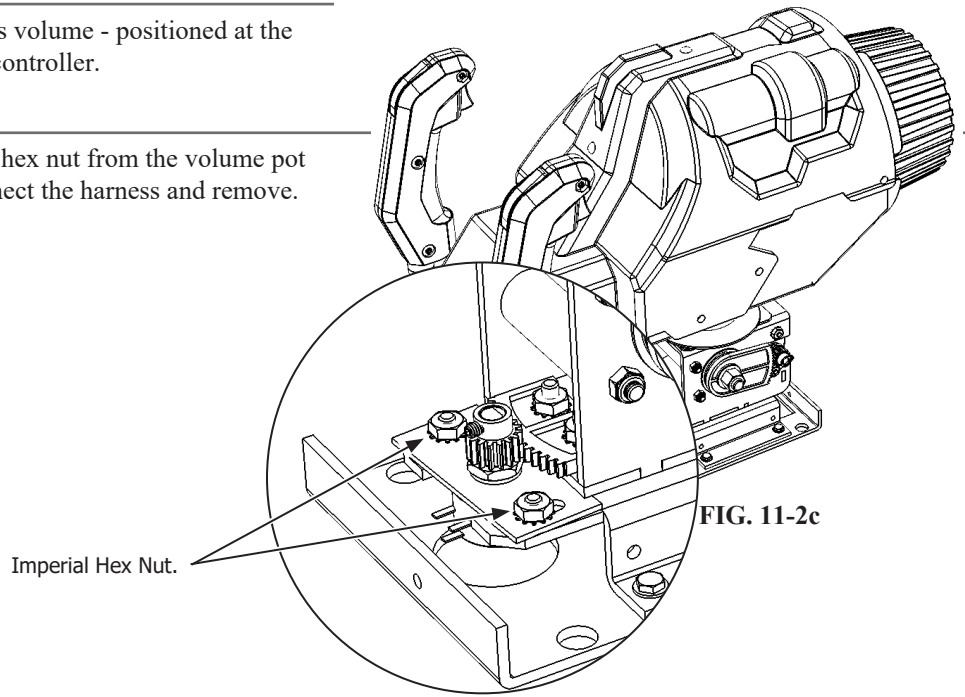

FIG. 11-2c

4 Loosen the single hexagonal grub screw on the volume pot gear and remove the gear.

5 Remove the nut which secures the volume pot to the volume pot bracket and separate.

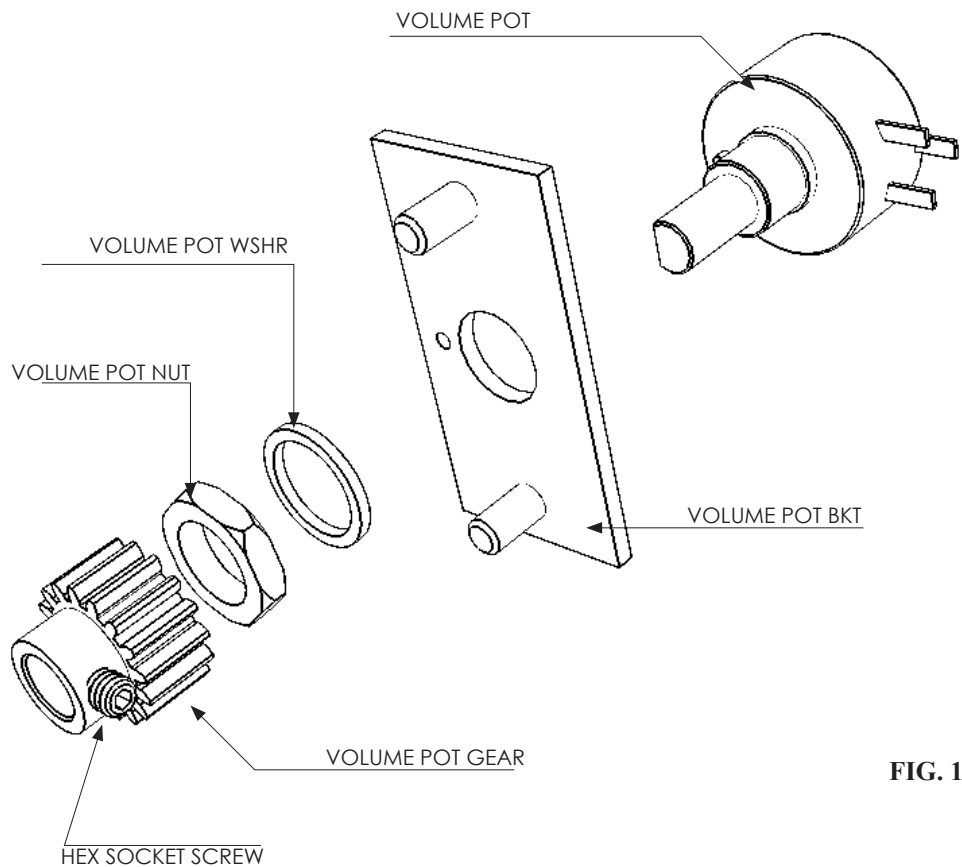

FIG. 11-2d

6 The wire connected to the volume pot will be reused. Use a tool such as a pair of snips or cutters to remove the old heatshrink tubes which cover the contacts.

7 Use a soldering iron to melt the solder and separate the wires from the old volume pot. Be very careful when using a soldering iron.

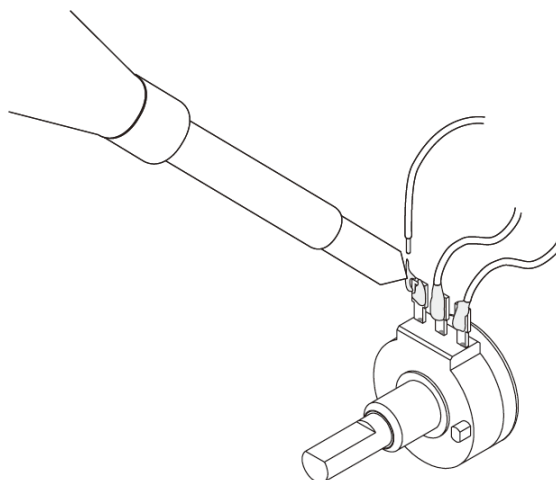

FIG. 11-2e

8 If the exposed conductive wire at the end is less than 5mm, use a tool such as a wire stripper or cutter to cut the wire insulation back to a workable length. Place new sleeving over the wire before resoldering them to the pot.

9 Once soldered, cover the bare contacts with the sleeving. If heatshrink is used, apply heat from an appropriate hot air blower to shrink the sleeving tightly over the contacts.

10 Reassemble the pot to the pot bracket by working in reverse order of these instructions. Refer to the POT VOLUME ADJUSTMENT section of this manual.

Greasing

STOP IMPORTANT

- Be sure to use the designated grease. Using undesignated grease can cause parts damage.
- Do not apply grease to locations other than as specified. Doing so may create a risk of operational problems and deterioration of parts.
- The designated periods for greasing serve only as a guide. Whenever there are squeaks or other anomalies, apply grease at designated locations.

Use spray grease once every three months to grease up the gear mesh portion of the constituent parts. Use "Grease Mate" (part number 090-0066) for the spray grease.

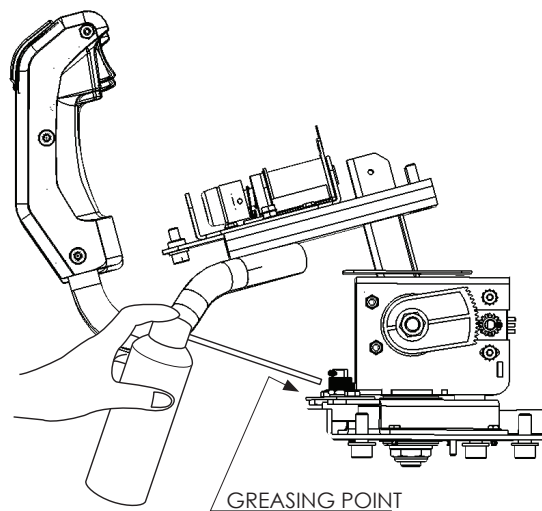

FIG. 11-2f

11-3 ADJUSTING OR CHANGING THE Y AXIS VOLUME

The Y (up and down) axis volume is on the bottom of the Control Unit.

If the Y axis volume does not seem to be working properly and the TEST Mode calibration screen has no effect, the cause is likely to be a problem with or damage to the gears of the Y axis volume.

When replacing the volume, you will need a replacement volume and three heat shrink tubes. You will also need the following tools and some solder:

- Wrench or screwdriver for tamperproof screws (for M4)
- A 7 millimeter spanner, hexagonal screwdriver, or socket wrench
- An 11-12 millimeter spanner
- Cutters
- Wire stripper
- Soldering iron
- Industrial heat gun

Adjustment

1 Turn off the power and remove the Control Unit (see 11-1).

2 Locate the Y axis volume - positioned at the right hand side of the controller.

3 Loosen the (2) hex nut from the volume pot bracket. Disengage the volume gear by sliding the bracket out towards the front of the controller.

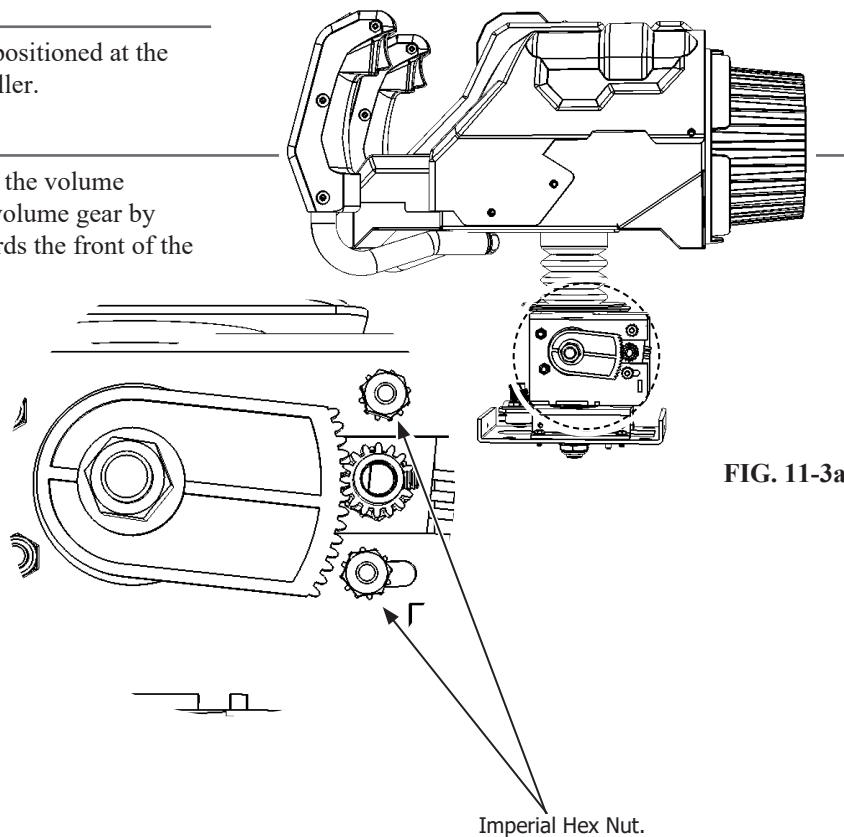
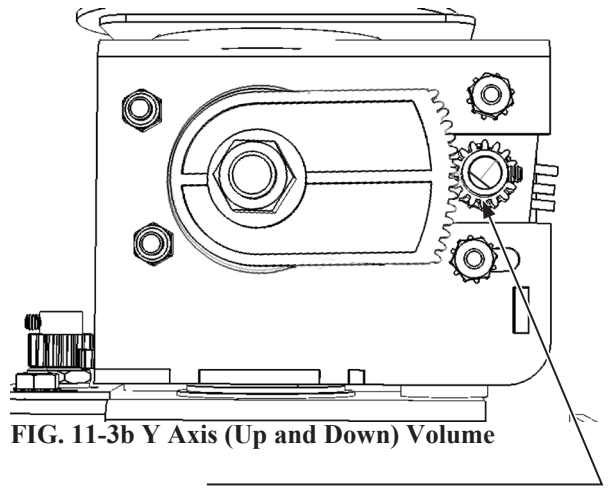

FIG. 11-3a

- 4 With the gear disengaged and the Control Unit's pointing in the upper most position, make sure that the D-Cut in the Volume pot is positioned as it is in FIG 11-3b



Position of Volume axis D cut face when controller pointing upper most position.

- 5 Engage the gears and tighten the two previously loosened screws.
- 6 Move the Control Unit up and down and check that the gears move smoothly.
- 7 Reattach the Control Unit, then turn on the power and adjust the volume value on the calibration screen.

Replace

- 1 Turn off the power and remove the Control Unit (see 11-1).
- 2 Locate the X axis volume - positioned at the rear base of the controller.
- 3 Unscrew the (2) hex nut from the volume pot bracket. Disconnect the harness and remove.

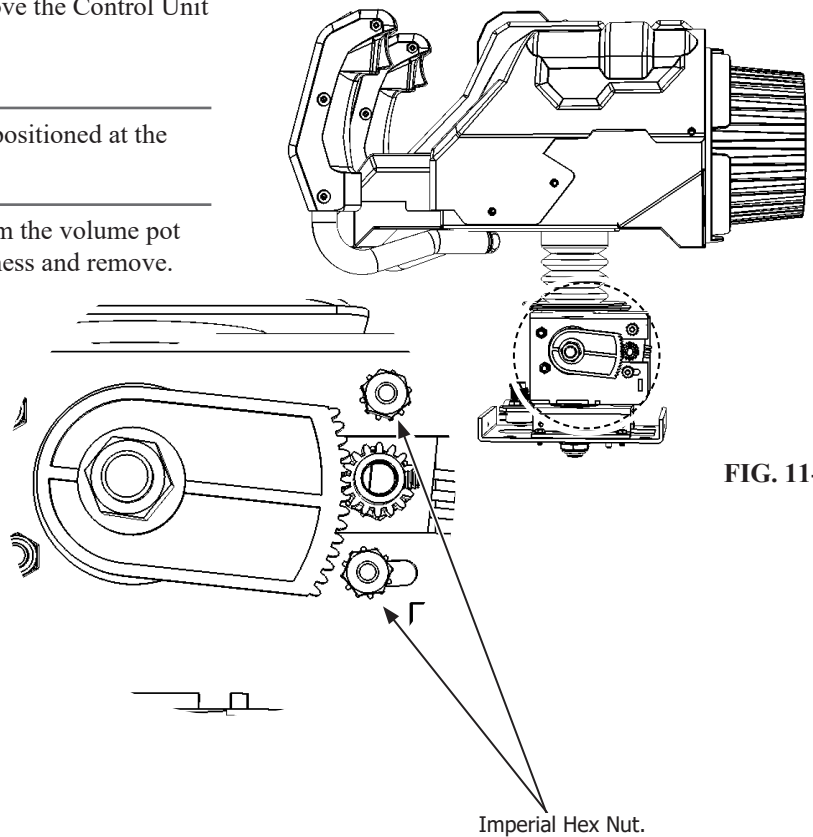
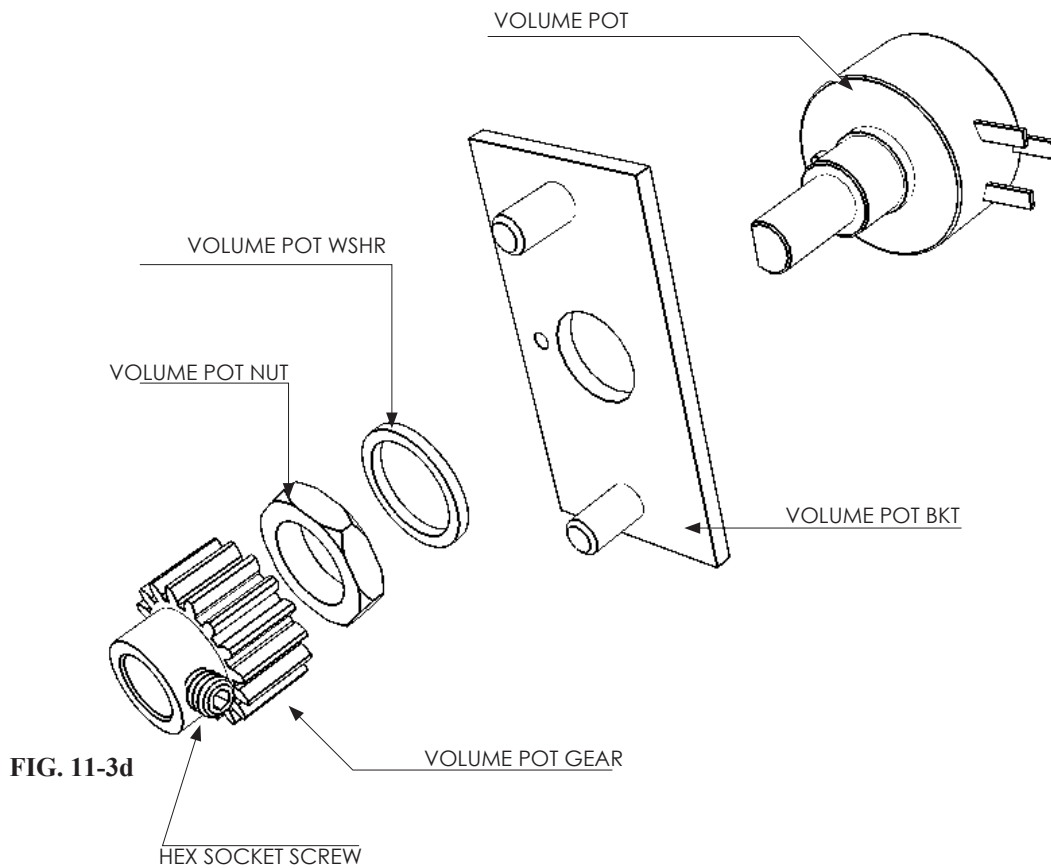

FIG. 11-3c

4 Loosen the single hexagonal grub screw on the volume pot gear and remove the gear.

5 Remove the nut which secures the volume pot to the volume pot bracket and separate.



6 The wire connected to the volume pot will be reused. Use a tool such as a pair of snips or cutters to remove the old heatshrink tubes which cover the contacts.

7 Use a soldering iron to melt the solder and separate the wires from the old volume pot. Be very careful when using a soldering iron.

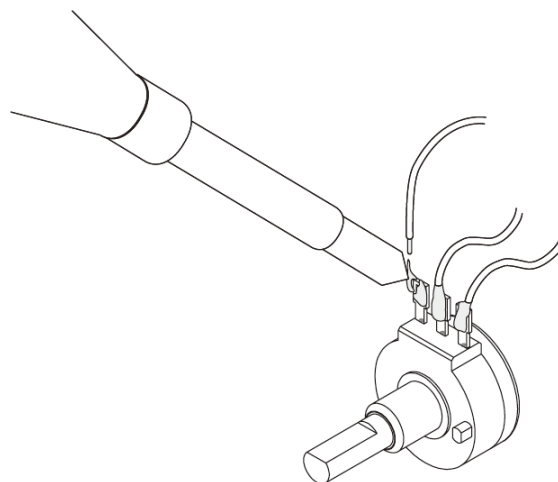

- 8** If the exposed conductive wire at the end is less than 5mm, use a tool such as a wire stripper or cutter to cut the wire insulation back to a workable length. Place new sleeving over the wire before resoldering them to the pot.
- 9** Once soldered, cover the bare contacts with the sleeving. If heatshrink is used, apply heat from an appropriate hot air blower to shrink the sleeving tightly over the contacts.
- 10** Reassemble the pot to the pot bracket by working in reverse order of these instructions. Refer to the POT VOLUME ADJUSTMENT section of this manual.

Greasing

STOP IMPORTANT

- Be sure to use the designated grease. Using undesignated grease can cause parts damage.
- Do not apply grease to locations other than as specified. Doing so may create a risk of operational problems and deterioration of parts.
- The designated periods for greasing serve only as a guide. Whenever there are squeaks or other anomalies, apply grease at designated locations.

Use spray grease once every three months to grease up the gear mesh portion of the constituent parts. Use "Grease Mate" (part number 090-0066) for the spray grease.

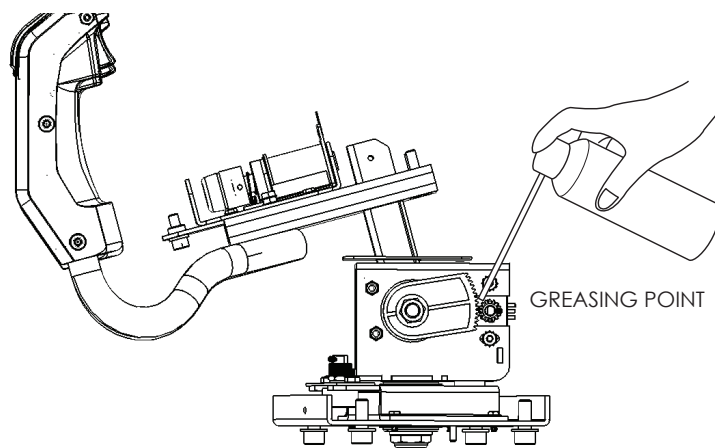

FIG. 11-3f

11-4 REPLACING THE TRIGGER SWITCH

If the trigger does not seem to be working properly, it is likely a fault with the microswitch inside the Control Unit's grip or there is foreign matter or dirt on the trigger. Remove the Control Unit when exchanging the microswitch or when disassembling and cleaning individual parts.

When replacing the microswitch, you will need a replacement microswitch and two heat shrink tubes. You will also need the following tools and some solder:

- Phillips head screwdriver (for M4,)
- Wrench or screwdriver for tamperproof screws (for M4)
- An 8 millimeter spanner or hexagonal screwdriver or socket wrench.
- Nippers
- Cutters
- Soldering iron
- Industrial dryer

The microswitch slots into the left hand part of the grip, the left grip. During this operation you will remove and replace the right hand part of the grip, the right grip.

The screws and nuts fixing the grip in place are treated as part of this product. If you lose them they can be reordered using their respective product numbers.

1 Turn off the power and remove the Control Unit (See 11-1).

2 Disassemble the grip with the microswitch inside it. The top screw on the right grip uses a hexagon nut. Use a Phillips head screwdriver (for M4 screw).



FIG. 11-4a

3 Remove the two tamperproof screws holding the right grip in place. Use a wrench or screwdriver for tamperproof screws (for M4).



FIG. 11-4b

- 4** Remove the right grip. Be careful when removing the grip as the pieces inside may come free. When disassembling and cleaning individual parts, be careful of the direction you attach the trigger bumper. Attaching it in the wrong direction may lead to a malfunction in the operation of the trigger.



FIG. 11-4c

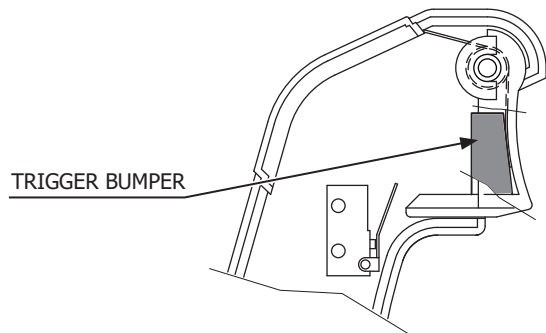

FIG. 11-4d

- 5** The microswitch is slotted into the left grip. Remove it gently, being careful not to damage the wires.



FIG. 11-4e

- 6** The wire attached to the microswitch will be used with the replacement microswitch. Remove the old heat shrink tubing attached to the wire using the nippers or cutters.
- 7** Use the soldering iron to remove the wire soldered to the microswitch terminal.
- 8** Pass the wire through each of the heat shrink tubes.
- 9** Solder the wire to the terminal on the replacement microswitch. Use the wiring diagram to make sure you don't solder in the wrong place.

10 Use the industrial dryer to apply heat and attach the heat shrink tubing to the soldered area.

11 Insert the microswitch into the left grip and attach it.

12 Reattach the right grip, taking care not to pinch the wire. Replace the two tamperproof screws, screw and nut to fix it in place. Be careful not to tighten the screws too tightly.

13 Reattach the Control Unit to the cabinet.

14 Turn on the power and use the input test screen in GAME TEST Mode to check the operation of the trigger.

11-5 REPLACING THE FEEDBACK COIL

The X (left and right) axis volume is on the bottom of the Control Unit.

If the X axis volume does not seem to be working properly and the TEST Mode calibration screen has no effect, the cause is likely to be a problem with or damage to the gears of the X axis volume.

When replacing the feedback coil, you will need a replacement coil and two heat shrink tubes. You will also need the following tools and some solder.

11 CONTROL UNIT

- Wrench or screwdriver for tamperproof screws (for M4)
- A 7 millimeter spanner, hexagonal screwdriver, or socket wrench
- An 11-12 millimeter spanner
- Cutters
- Wire stripper
- Soldering iron
- Industrial heat gun

1 Turn off the power and remove the Control Unit (See 11-1).

2 Unscrew and remove the controller cover. Once all (8) screws have been removed, carefully lift off the cover from the controller.

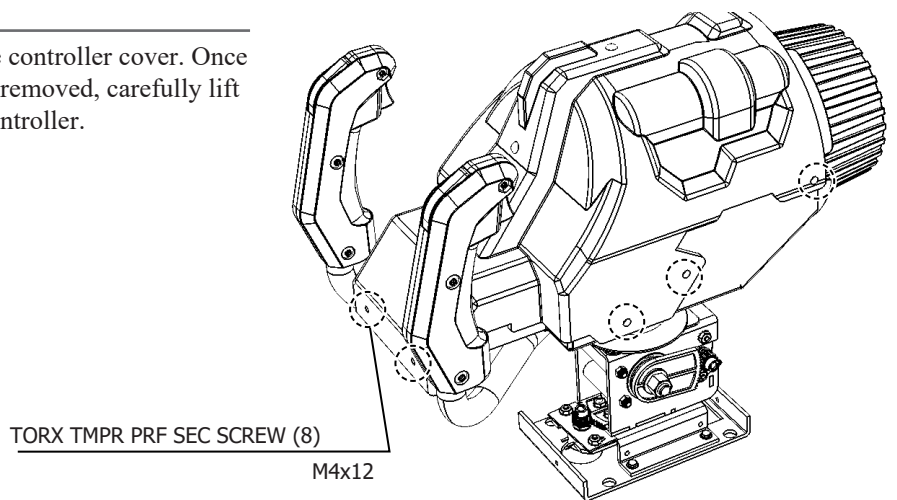

FIG. 11-5a

3 Using an open ended spanner or nut runner, remove the (4) Hex Nut which secure the coil assy to the controller.

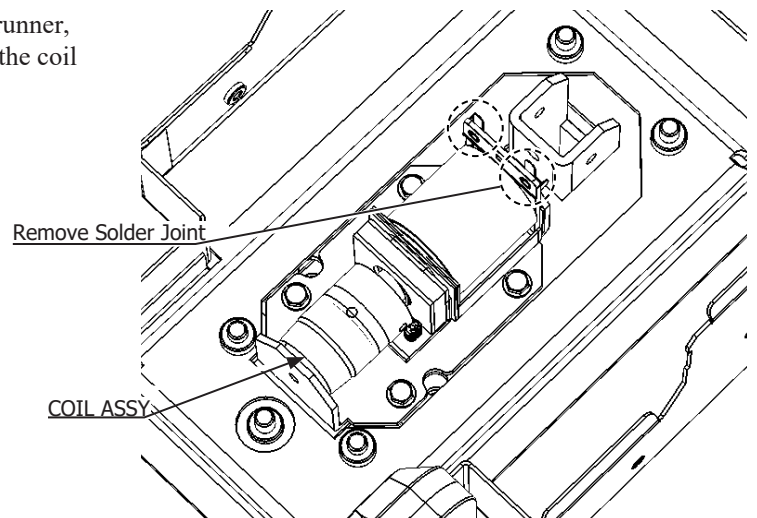

FIG. 11-5b

Note: This image has been modified to easy illustration

-
- 4** Once the coil has been desoldered, unscrew and remove the (4) Hex Nut which secure the Coil Assy to the Controller.

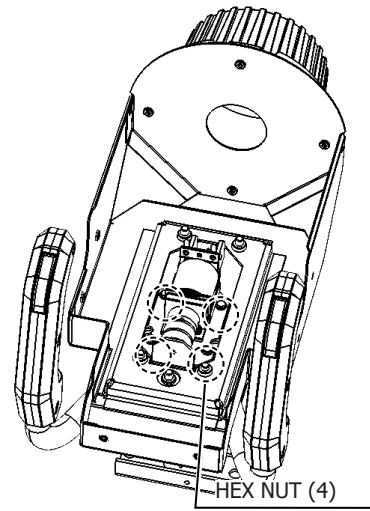

FIG. 11-5c

-
- 5** The Coil Assy may be broken down further into individual components, but for the purpose of this exercise only the assembly is removed.

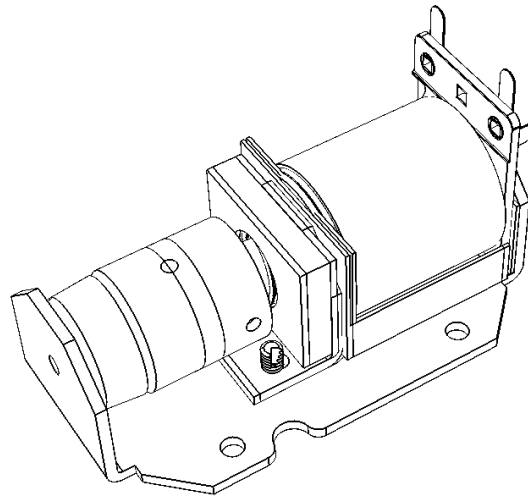

FIG. 11-5d

12 COIN HANDLING

Handling the Coin Jam

If the coin is not rejected when the REJECT button is pressed, open the coin chute door and open the selector gate. After removing the jammed coin, put a normal coin in and check to see that the selector correctly functions.

12

COIN HANDLING

12-1 CLEANING THE COIN SELECTOR

STOP IMPORTANT

- Remove and clean smears by using a soft cloth dipped in water or diluted chemical detergent and then squeezed dry.
- Never apply machine oil, etc. to the Coin Selector.
- After cleaning the Coin Selector, insert a regular coin in the normal working status and ensure that the selector correctly functions.

The Coin Selector should be cleaned once every 3 months. When cleaning, follow the procedure below:

- 1 Turn the power for the machine OFF. Open the Coin Chute Door
- 2 Remove the Coin Selector from the Coin Chute Door
- 3 Open the gate and dust off by using a soft brush (small soft Paint Brush, etc.)

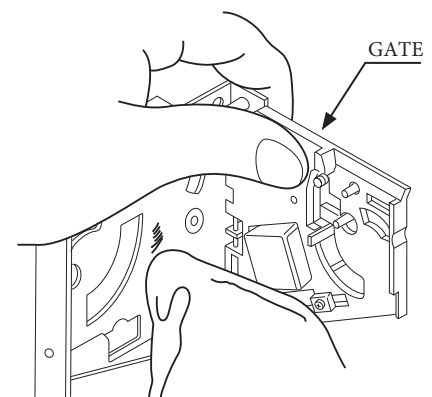

12-1 FIG 1

CLEANING THE COIN SELECTOR (MECHANICAL).

1 Remove and clean smears by using a soft cloth dipped in water or diluted chemical detergent and then squeezed dry.

2 Remove the CRADLE.. When removing the retaining ring (E ring) be very careful so as not to bend the rotary shaft.

3 Remove stain from the rotary shaft and shaft receiving portions by wiping off with a soft cloth. etc.

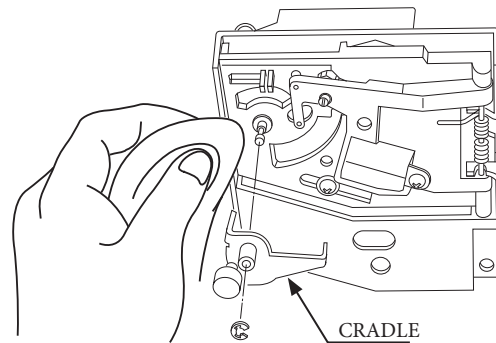

12-1 FIG 2

4 After wiping off as per previous step, further apply a dry cloth to completely dry the Coin Selector.

Coin Insertion Test

Once every month, when performing the Coin SW Test, simultaneously check the following:

Does the Coin Meter count satisfactorily?

Does the coin drop into the cashbox correctly?

Is the coin rejected when inserted while keeping the REJECT Button pressed down?

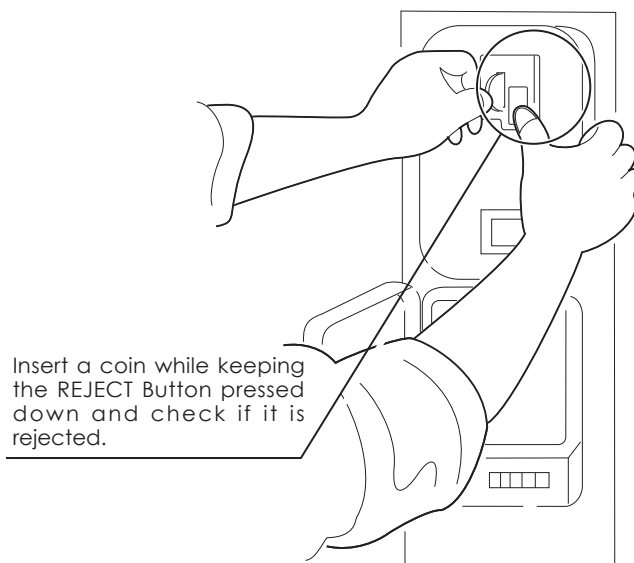

12-1 FIG 3

CLEANING THE COIN SELECTOR (SR3 / NRI)

12

COIN HANDLING

- 1 Remove and clean smears by using a damp soft cloth dipped in water. DO NOT use any diluted chemical detergent or cleansing agent as this will impair the workings of the component.

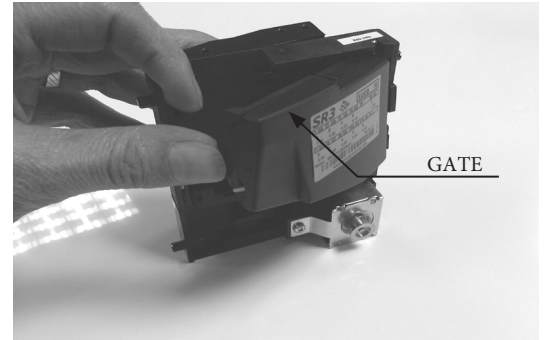

- 2 Open the reject gate to gain access to the rundown path.

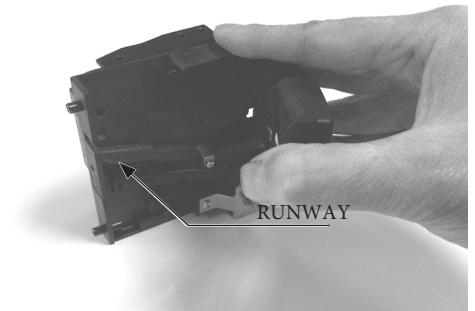

- 3 Remove the dirt and stains from the runway by wiping off with a soft damp cloth.



- 4 After wiping off as per previous step, further apply a dry cloth to completely dry the coin Selector.

12-2 FAULT FINDING

Fault Finding

The following information is presented for customers' guidance in rectifying a fault but does not cover all possible causes.

All acceptors with electronic faults should be returned to an approved service centre for repair.

SYMPTOM	INVESTIGATE	POSSIBLE CAUSE
Acceptor does not work (all coins reject)	Connector	Poor Contact
		Loose Wire
	Power Supply	Not switched on
		Incorrect voltage
		Inadequate current
		Rise time too slow
	Inhibit all inputs	Acceptor Inhibited
	Accept gate	Gate not free or dislocated
	Accept channel	Obstruction
	Reject gate	Not fully closed
	LED on rear cover RED	EEPROM chksm error
		SR Sensor fault
		Credit opto fault
Credit sensor blocked		
	Reject lever pressed	
LED on rear cover YELLOW	Reinstall power	
Poor Acceptance	Power Supply	Voltage less than 10v (Voltage drops when coil engages)
	Accept gate	Gate jam or dislocated
	Connector	Loose
	Coin rundown	Dirty
	Bank Select	Both banks enabled
Coin stick or jam in acceptor	Accept channel	Acceptor dirty or may have some damage
	Accept gate	
	Reject gate	
A true coin type rejects	Label	Coin not programmed
No accept signal	Connector	Loose or broken wire
	Accept channel	Path dirty or obstructed

12-3 ADJUSTING THE PRICE OF PLAY (EXCEL)

STOP IMPORTANT

- The price of play is determined by the configuration of switches located on either the EXCEL or VTS board. The type of board used is determined by product location. Switch settings for both types of board remain the same.

This product comes equipped with a Crane NRI Coin Acceptor. To adjust the price of play ALL CREDIT SETTINGS are adjusted via the EXCEL CREDIT BOARD.

IMPORTANT!

The CREDIT SETTINGS within the SYSTEM TEST MODE must be set to 1 coin 1 credit to allow the CREDIT BOARD to function correctly.

The CREDIT BD has a built in accumulator. This is controlled by 2 DIL Switches. These allow the operator to select the price of play, type of coin acceptor and region.

EXCEL Credit Board

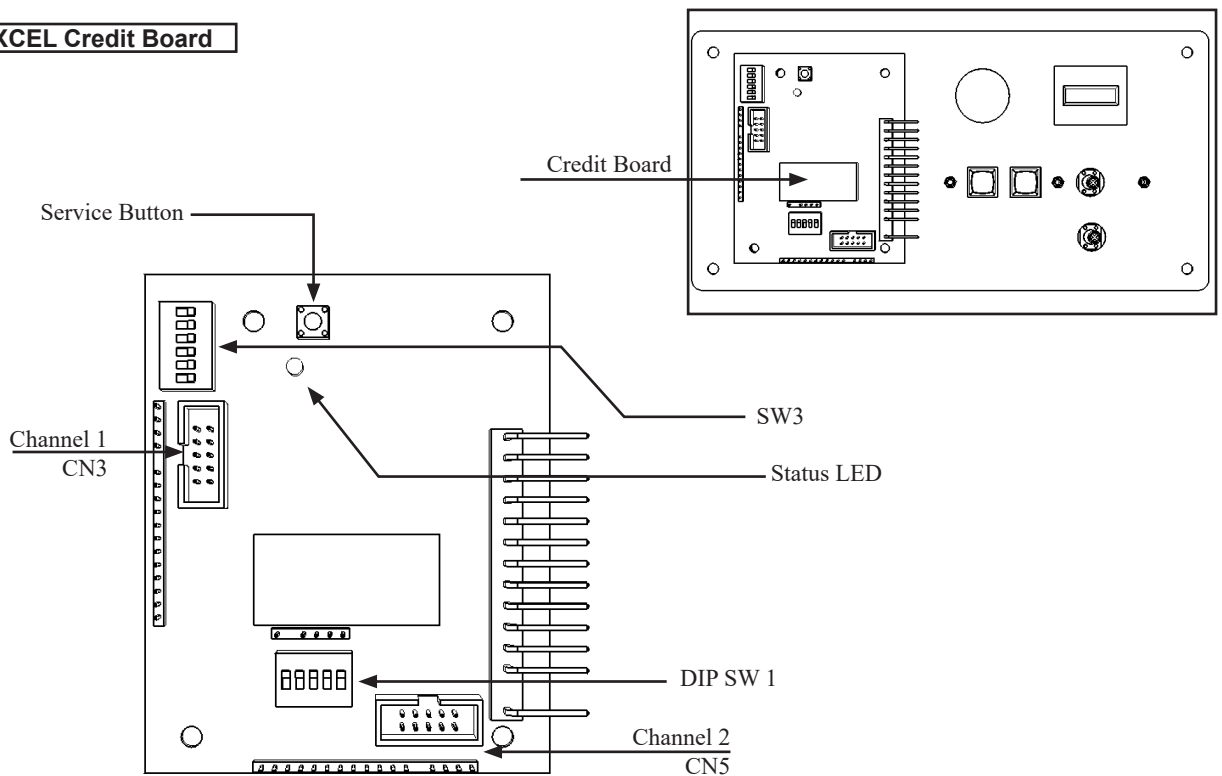

DIL SW3 (Regional Settings)

Adjust these switches to specify the type of Coin Acceptor used and currency.

Default = SW1&SW2 ON - SR3/NRI in parallel mode, Sterling.

SERVICE BUTTON

Status LED

CHANNEL 1

DIL SW1 (credit settings)

VOL CONTROL

Provides a SERVICE CREDIT when pressed

Flashes when functioning.

To Coin Acceptor (SR3 TYPE.)

Adjust to required price of pay.

MAIN VOLUME ADJUSTMENT (FRONT SPEAKERS)

12-4 ADJUSTING THE PRICE OF PLAY (VTS)

This product comes equipped with a Crane NRI Coin Acceptor. To adjust the price of play ALL CREDIT SETTINGS are adjusted via the VTS CREDIT BOARD.

IMPORTANT!

The CREDIT SETTINGS within the SYSTEM TEST MODE must be set to 1 coin 1 credit to allow the CREDIT BOARD to function correctly.

The VTS BD has a built in Credit Board. This is controlled by 2 DIL Switches. These allow the operator to select the price of play, type of coin acceptor and region.

VTS Board

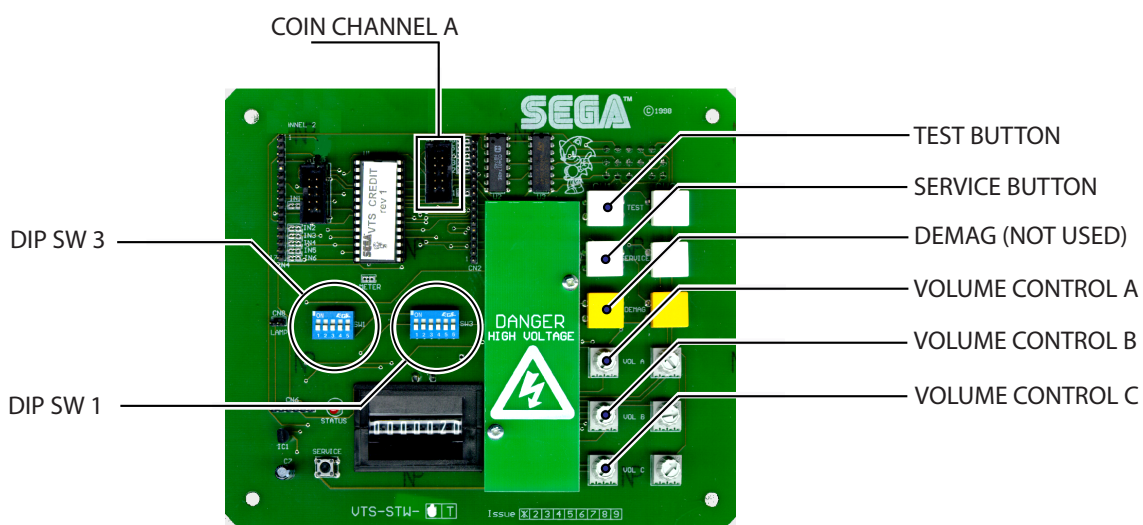

DIL SW3 (Regional Settings)

Adjust these switches to specify the type of Coin Acceptor used and currency.

Default = SW1&SW2 ON - SR3 in parallel mode, Sterling.

TEST BUTTON	Provides access to the TEST MENU when pressed.
SERVICE BUTTON	Provides a SERVICE CREDIT when pressed
Status LED	Flashes when functioning.
CHANNEL A	To Coin Acceptor (SR3 TYPE.)
DIL SW1 (credit settings)	Adjust to required price of pay.
DEMAG	NOT USED
VOL CONTROL A	MAIN VOLUME ADJUSTMENT (FRONT SPEAKERS)
VOL CONTROL B	SECONDARY VOL ADJUSTMENT (GUN SPEAKERS)
VOL CONTROL C	NOT USED

13 LAMPS AND LIGHTING

⚠ WARNING

- When working with the product, be sure to turn the power off. Working with the power on may cause an electric shock or short circuit.
- You may get burned by a hot fluorescent lamp or other lamps. Pay full attention to the lamps when performing the work.
- Be sure to use lamps of the designated rating. Using lamps of undesignated rating can cause a fire or malfunctioning.
- There is the danger of short circuits or smoke generation due to deterioration of insulation in lighting fixtures resulting from age deterioration. Check for anomalies such as the following: Does it smell like something is burning? Is there socket discoloration? Are any lamps being replaced frequently? Do lamps not go on properly?

⚠ CAUTION

The Coin Door Lamp utilises a 12v 1.2w Wedge Bulb. It is important that you replace this bulb or any other bulb of that of the same voltage and rating. Failing to observe this caution may result in PCB failure or possible fire hazard.

13-1 COIN DOOR LAMP

Step 1. Open the Coin Door and locate the Lamp Housing directly behind the Coin Insert Bezel.

Lamp Housing

Step 2. Hold the Lamp Housing firmly between your index finger and thumb and gently pull upwards. Do not try to remove the Lamp Housing whilst holding the bulb as the bulb may break causing injury.

Step 3. Once the Lamp Housing has been removed, carefully hold the bulb between your fingers and pull the Lamp Housing away.

Do not twist either bulb or Lamp Housing while removing the bulb as this may cause damage to both bulb and/or Housing.

Type: Wedge Bulb - 12v, 1.2w

Step 4. Simply push-fit a replacement bulb of the same type and follow these steps in reverse to refit.

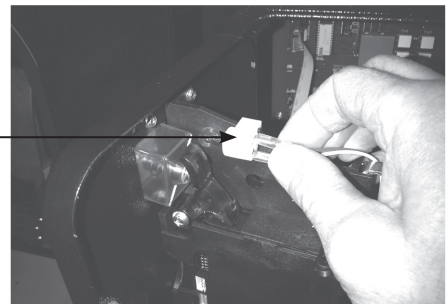

FIG. 13-1a



FIG. 13-1b

13-2 START BUTTON LAMP

- 1 Turn off the power.
- 2 Unlock and open the Cabinet coin door.

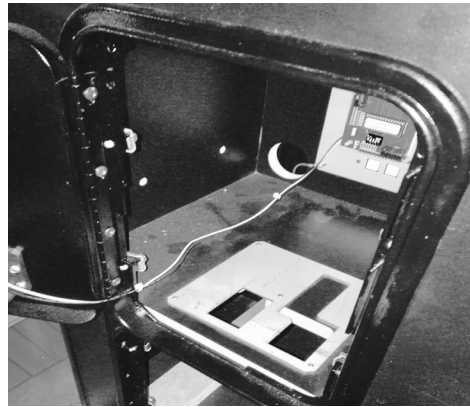

FIG. 13-2a

- 3 Remove Lamp and Switch housing from the Button by pulling the housing away from the button. These can sometimes be a little tight upon initial removal.

Lamp Housing

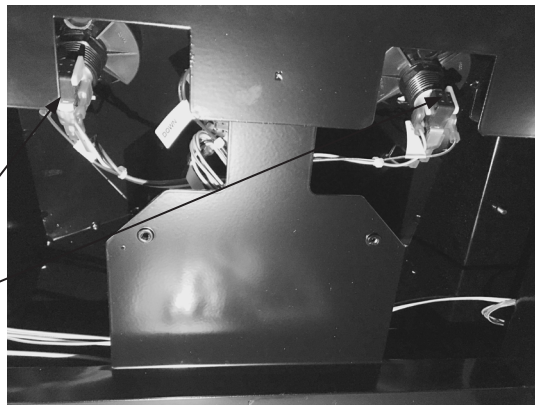

FIG. 13-2b

- 4 The bulb is a simple “push fit” type. Simply hold onto the bulb and pull directly out of the socket. DO NOT twist the bulb as this will cause the bulb to shatter which inturn may result in an injury



FIG. 13-2c

- 5 Replace the bulb for that of the same type. Place the bulb and switch housing back into the button assembly and resecure coin door

BULB WEDGE TYPE
12v 1.2W

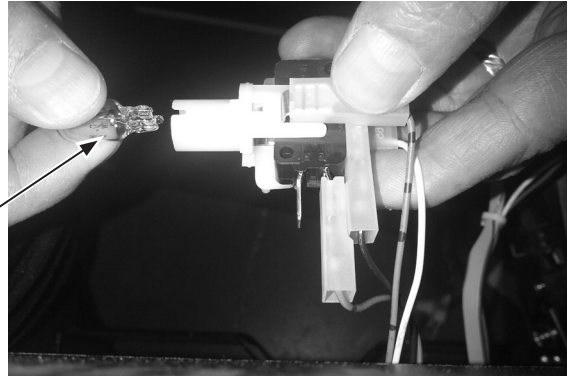

FIG. 13-2d

14 PERIODIC INSPECTION

The items listed below require periodic check and maintenance to retain the performance of this machine and to ensure safe business operation.

When handling the controller, the player will be in direct contact with it. In order to always allow the player to enjoy the game, be sure to clean it regularly. Also, it is advisable to provide wet tissues, etc. available for player use.

WARNING

- **Every 6 months check to see if power cords are damaged, the plug is securely inserted, no dust has accumulated between the socket outlet and the power plug, etc. Using the product with accumulated dust in the interior may cause fire or electric shock.**
- **Never use a water jet, etc. to clean the inside or outside of the cabinet. If wetness occurs for any reason, do not use the product until it has completely dried.**
- **Once a year, request the office shown on this manual or the dealer from whom the product was originally purchased to perform the internal cleaning. Using the product with accumulated dust in the interior may cause fire or other accidents.**
- **Note that you are liable for the cost of cleaning the interior parts.**
- **There is the danger of accidents involving electrical shorts circuits or fire caused by factors such as the deterioration of insulation in electrical and electronic equipment over time. Check that there are no abnormalities such as odours from burning.**

14 TABLE 01 PERIODIC INSPECTION TABLE

PERIOD	ITEM	DESCRIPTION	REFERENCE
As appropriate	Cabinet Surface	Cleaning	As Below
	Control Unit Surface		
Daily	Cabinet	Confirm Adjusters Contact Floor	
Weekly	Control Unit	Aim Test	
	LCD	Screen Cleaning	
		Screen Alignment	
Monthly	Front Cabinet	Speaker Volume	
	Controller Cabinet	Check Input Devices	
		Check Output Devices	
	Controller Unit	Check Speaker Volume	
		Speaker Inspection	
		Check Each Input Device	
	LED board	LED Inspection	
	Coin Selector	Coin Path Inspection	
Coin Insertion Test			
Every 3 Months	Coin Selector	Cleaning	
1 Year	Game BD	Cleaning	
	Power Cables	Inspection / Cleaning	
	Cabinet Interior	Cleaning	

Cleaning the Cabinet Surfaces

When the cabinet surfaces are badly soiled, remove stains with a soft cloth dipped in water or diluted (with water) chemical detergent and squeezed dry. To avoid damaging surface finish, do not use solvents such as thinner, benzine, etc. other than ethyl alcohol, or abrasives, bleaching agent and chemical dustcloth.

Some general-purpose household, kitchen and furniture cleaning products may contain strong solvents that degrade plastic components, coatings, and print. Before using any cleaning product, read the product's cautionary notes carefully and test the product first on a small area that is not highly visible.

15 TROUBLESHOOTING

15-1 TROUBLESHOOTING (WHEN NO ERROR MESSAGE IS SHOWN)

WARNING

- This work should be performed by site maintenance personnel or other skilled professionals. Work performed by non-technical personnel can cause a severe accident such as an electric shock. If there are no site maintenance personnel or other skilled professionals available, turn off the power immediately and contact the office given in this manual or from point of purchase.
- When working with the product, be sure to turn the power off. Working with the power on may cause an electric shock or short circuit accident.
- In order to prevent electric shock and short circuit, be sure to turn power off before performing work.
- Be careful so as not to damage wirings. Damaged wiring can cause electric shock or short circuit.
- After removing the cause of the functioning of the Circuit Protector, reinstate the Circuit Protector. Depending on the cause of the functioning, using the Circuit Protector as is without removing the cause can cause generation of heat and fire hazard.
- In the event that a problem cannot be resolved by employing the procedures listed in this Manual, be sure to request service from the office shown in this Manual or the dealer from whom the product was originally purchased. Attempts to employ procedures other than those specified in this Manual can cause electrical shock, shorting, or fire.
- In the event of a problem that is not described here, be sure to contact the office shown on this Manual or the dealer from whom the product was originally purchased. Careless attempts at repair can result in electrical shock, shorting, or fire.

IMPORTANT

- If an error message is displayed, identify the cause and without delay take the appropriate countermeasures. Leaving the error unaddressed could result in a breakdown.
- If a problem occurs, first inspect the connection of any wiring connectors.
- Static electricity from your body may damage some electronic devices on the IC board. Before handling any IC board, touch a grounded metallic surface so that static electricity is discharged.

If a problem occurs, first check to make sure that the wiring connectors are properly connected.

15 TABLE 01

PROBLEM	CAUSE	COUNTERMEASURES
When the Main SW is turned ON, the machine is not activated.	The power is not ON	Firmly insert the plug into the outlet
	Incorrect power source/voltage	Make sure that the power supply/voltage are correct
	The Fuse on the AC Unit has blown due to momentary over current	After eliminating the cause of overload, replace the specified rating fuse
	The Fuse of the Connect Board has blown due to momentary over current	After eliminating the cause of overload, replace the specified rating fuse
No sound is generated from the speakers	Volume not correctly adjusted	Adjust the sound volume (see chapter 9)
	Game Bd or Amplifier malfunction	Call service dept mentioned in this manual
LCD colour incorrect	Screen not correctly adjusted	Adjust the screen (see chapter 11)
	VGA cable malfunction	Replace VGA cable
	LCD failure	Call service dept mentioned in this manual
The controller line of sight is not acceptable	Sights are not aligned due to changes in the surrounding environment	Re-align the sight settings (see chapter 9)
	Sight LED board malfunction.	Check LED bds positioned around the screen - check that all LEDs are lit (This can be easily achieved if viewing LED through a digital device i.e camera or camera phone)
	Sensor unit malfunction	Replace sensor unit. (see chapter 10)
	LED Board / cover contaminated	Clean both LED covers and LEDs
The controller unit does not appear to operate correctly	Microswitch failure	Check using Input Test (see chapter 9) to establish operation
	LED board malfunction	Check LED bds positioned around the screen - check that all LEDs are lit (this can be easily achieved if viewing LED through a digital device i.e camera or camera phone)
	Sensor Unit malfunction	Replace the Sensor Unit (see chapter 10)

WARNING

- When working with the product, be sure to turn the power off. Working with the power on may cause an electric shock or short circuit.
- Be careful not to damage the wires. Damaged wires may cause electric shock, short circuit or present a fire risk.
- Do not expose the game board, etc. without good reason. Failure to observe this can cause electric shock hazard or malfunctioning.
- Do not use this product with connectors other than those that were connected and used with the game board at the time of shipping. Do not carelessly connect wires to connectors that were not used at the time of shipping as this may cause overheating, smoke, or fire damage.
- When returning the game board after making repairs or replacements, make sure that there are no errors in the connection of connectors. Erroneous connections can lead to electrical shock, short circuits or fires.
- When connecting a connector, check the direction carefully. Connectors must be connected in only one direction. If indiscriminate loads are applied in making connections, the connector or its terminal fixtures could be damaged, resulting in electrical shock, short circuits, or fires.

CAUTION

- In this product, setting changes are made during the test mode. The game board need not be operated. Use the game board, etc. as is with the same setting made at the time of shipment so as not to cause electric shock and malfunctioning.
- Static electricity from your body may damage some electronics devices on the IC board. Before handling the IC board, touch a grounded metallic surface so that the static electricity can be discharged.

STOP IMPORTANT

- When a game board is to be replaced, put the old game board with anomaly into a special box for replacing the game board. If a special box is not available or if it has been damaged, arrange to have the Game Board packed in suitable packaging.
- For replacement or repair, pack the game board and send it without disassembling it. Order for servicing may not be accepted if any part of the game board has been removed. If any part is removed, a service fee will be charged even if the warranty period has not yet expired.
- Do not remove the key chip from the game board before sending the board for servicing.

16-1 HOW TO REMOVE GAME BOARD

The game board is inside the rear door mounted in the bottom right hand corner.

- 1 Turn off the power.
- 2 Remove the door release fixings (Phillips (2)) from the door.

(2) MSCR POZ BLK
M4x30

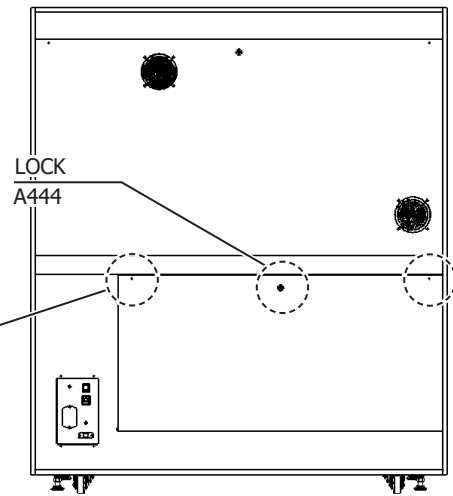

FIG. 16-1a

- 3 Unlock with the master key and remove the access door. The Game Bd is located in the bottom right corner.

GAME BD

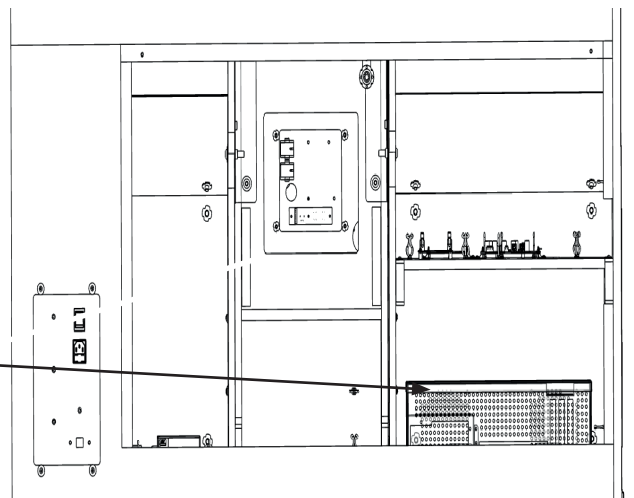

FIG. 16-1b

- 4 Disconnect all of the connectors connected to the Game Bd.

Carefully disconnect all
connection to from the
Game Bd

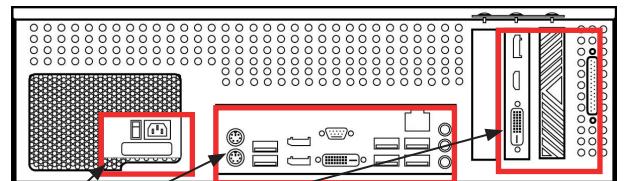
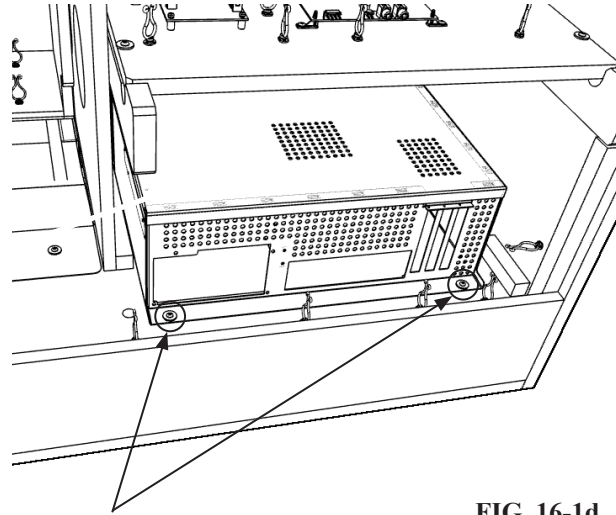

FIG. 16-1c

- 5** Unscrew the (2) M4 Phillips screws which secure the Game Board in place.



M4 FIXINGS (2)

FIG. 16-1d

- 6** Lift and remove the Game board from the cabinet. The Game Bd is HEAVY so take care not to clash with other components when removing as this could cause component damage.

16-2 COMPOSITION OF THE GAME BOARD

STOP IMPORTANT

- With the key chip inserted into it, this board serves as a special-purpose game board for the product.
- Use with the dip switches (DIP SW) on the board at the prescribed settings. If settings do not match the product, an error message will be displayed. In some cases, the game cannot be started.

DIP SW SETTING

Use this product with the DIP SW settings shown in the figure below.

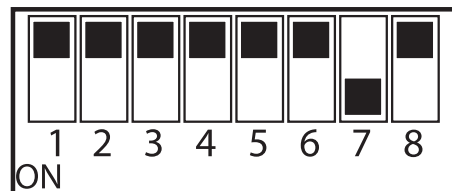

FIG. 16-2b

17 DESIGN RELATED PARTS

For the warning display stickers, refer to Section 1.



18 PARTS LIST

TRANSFORMERS SHADOWS RISING THEATRE STRUCTURE FLOW

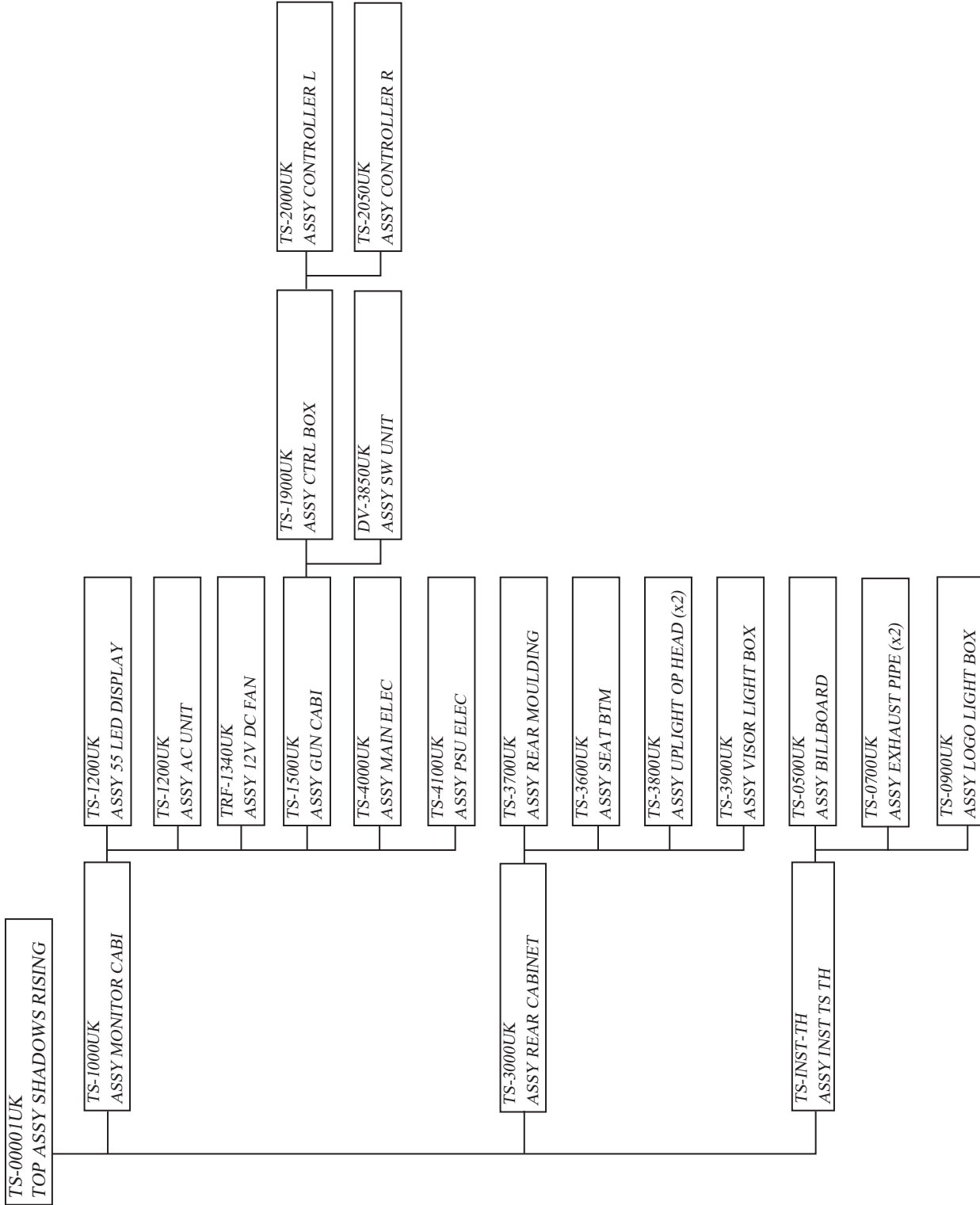

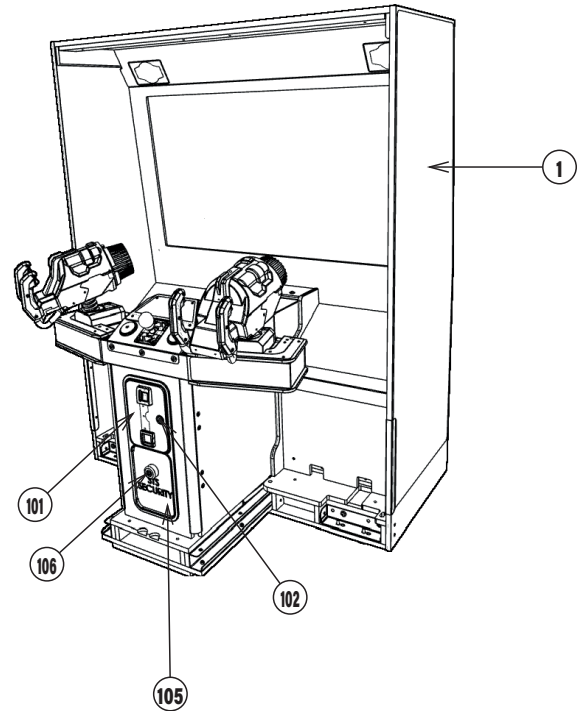
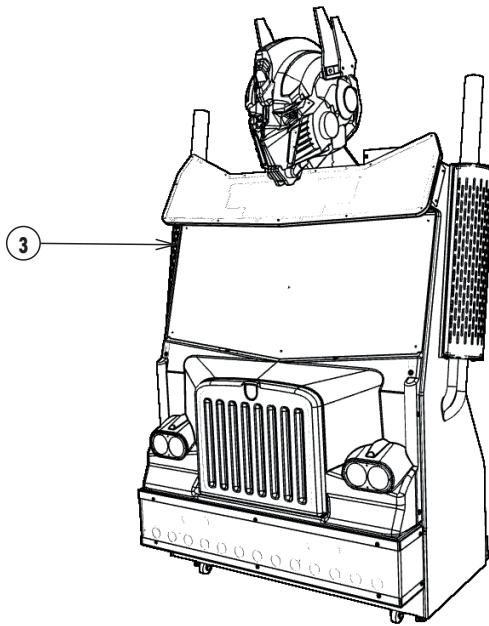

ITEM NO	PART NO	DESCRIPTION	QTY
*1	TS-1000UK	ASSY MONITOR CABI	1
*3	TS-3000UK	ASSY REAR CABINET	1
*20	421-7988-91UK	STICKER SERIAL NUMBER UK	2
*21	440-WS0100UK	WARNING LABEL FORK HERE	2
*22	440-DS0010UK	LABEL DANGER HI VOLT	
*23	LB1046	LABEL TESTED FOR ELEC. SAFETY	2
*24	LB1130	LABEL WEEE WHEELIE BIN	4
*25	440-CS0186-01UK	STICKER CAUTION EPILEPSY	3
*26	440-CS0010UK	LABEL CAUTION GENERIC	1
*101	220-5374-01	DOOR DFMD W/FR&LOCK C120 UNIV	1
*102	220-5575UK	LOCK (J9117) KEY TO LIKE 22MM W CAM	1
*103	OS1247	ALUMINIUM STICKY CLIP ASK-3	3
			1
*105	220-5727-01B	DOOR CASH H.S. STS	1
**106	220-5575-280UK	LOCK(J9117) 28MM W/O CAM	
*401	TS-INST-TH	ASSY INST TS TH	1
*410	PK0521	PALLET TS TH MON	1
*411	PK0484	SHRINK WRAP DV DX	1
*412	PK0517	PALLET TS TH REAR	

Please note: The location of all labels can be found in Chapter 1 of this manual.

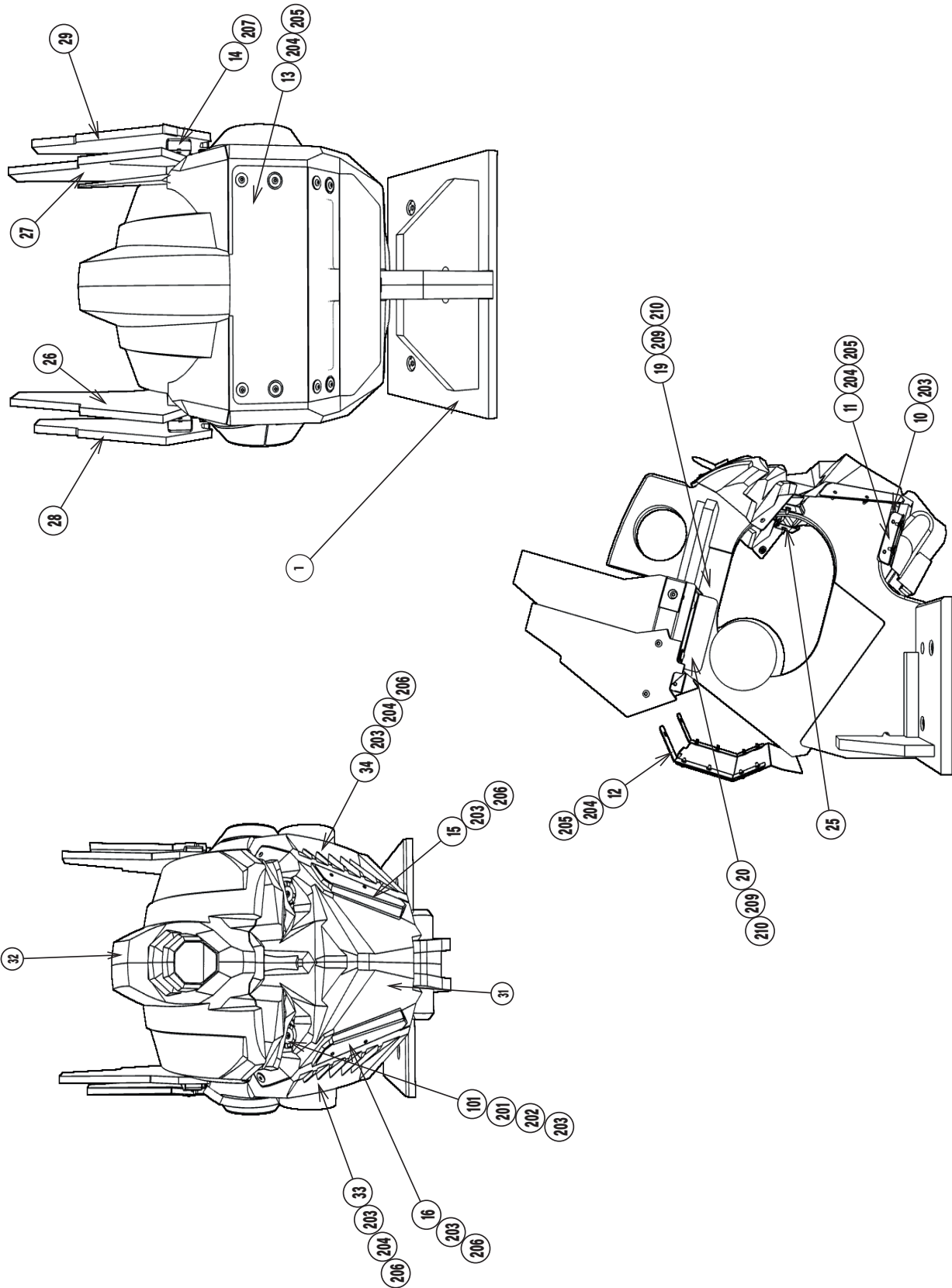

② ASSY BILLBOARD (TS-0500UK)

(D-2/2)

ITEM NO	PART NO	DESCRIPTION	QTY
***1	TS-0501XUK	BASE OP HEAD TILTED	1
***8	TS-0504UK	BRKT EYE MTG	2
***10	TS-0506UK	PLATE FACE FRONT SIDE JOIN	2
***11	TS-0507UK	BRKT FACE FRONT SIDE JOIN	2
***12	TS-0508UK	BRKT CLOSING HEAD BACK	2
***13	TS-0509UK	PLATE COVER	1
***14	TS-0510-01UK	BRKT ANTENNA MTG	2
***15	TS-0511UK	PLATE CHEEK L	1
***16	TS-0512UK	PLATE CHEEK R	1
***17	TS-0513UK	STICKER OP EAR INNER	2
***19	TS-0515UK	BRKT CROSS BRACE L	1
***20	TS-0516UK	BRKT CROSS BRACE R	1
***21	TS-0517UK	STICKER OP EAR OUTER L	1
***22	TS-0518UK	STICKER OP EAR OUTER R	1
***23	TS-0519UK	STICKER OP HELMET CENTRE	1
***25	TS-0521UK	BACK MOUNT SLED RING	2
***26	TS-0503-01-LUK	OP ANTENNA INNER L	2
***27	TS-0503-01-RUK	OP ANTENNA INNER R	2
***28	TS-0503-02-LUK	OP ANTENNA OUTER L	1
***29	TS-0503-02-RUK	OP ANTENNA OUTER R	1
***31	TS-0502-AUK	OP FACE	1
***32	TS-0502-BUK	OP HELMET	1
***33	TS-0502-CUK	OP FACE L	1
***34	TS-0502-DUK	OP FACE R	1
***101	390-2505-030-AD	SLED RING 030 M3028WS2812B	2
***201	029-B00425	M4X25 SKT BH PAS	2
***202	068-532030-PN	M5 WSHR 20OD FLT NYLON	2
***203	050-F00400	M4 NUT FLG SER PAS	18
***204	029-B00412-0B	M4X12 SKT BH BLK	16
***205	068-441616-0B	M4 WSHR 16OD FLT BLK	12
***206	068-441616	M4 WSHR 16OD FLT PAS	10
***207	029-B00630-0B	M6X30 SKT BH BLK	4
***208	029-B00625-0B	M6X25 SKT BH BLK	4
***209	029-B00840	M8X40 SKT BH PAS	4
***210	068-852216	M8 WSHR 22OD FLT PAS	4
***301	TS-60023UK	WH HEAD	

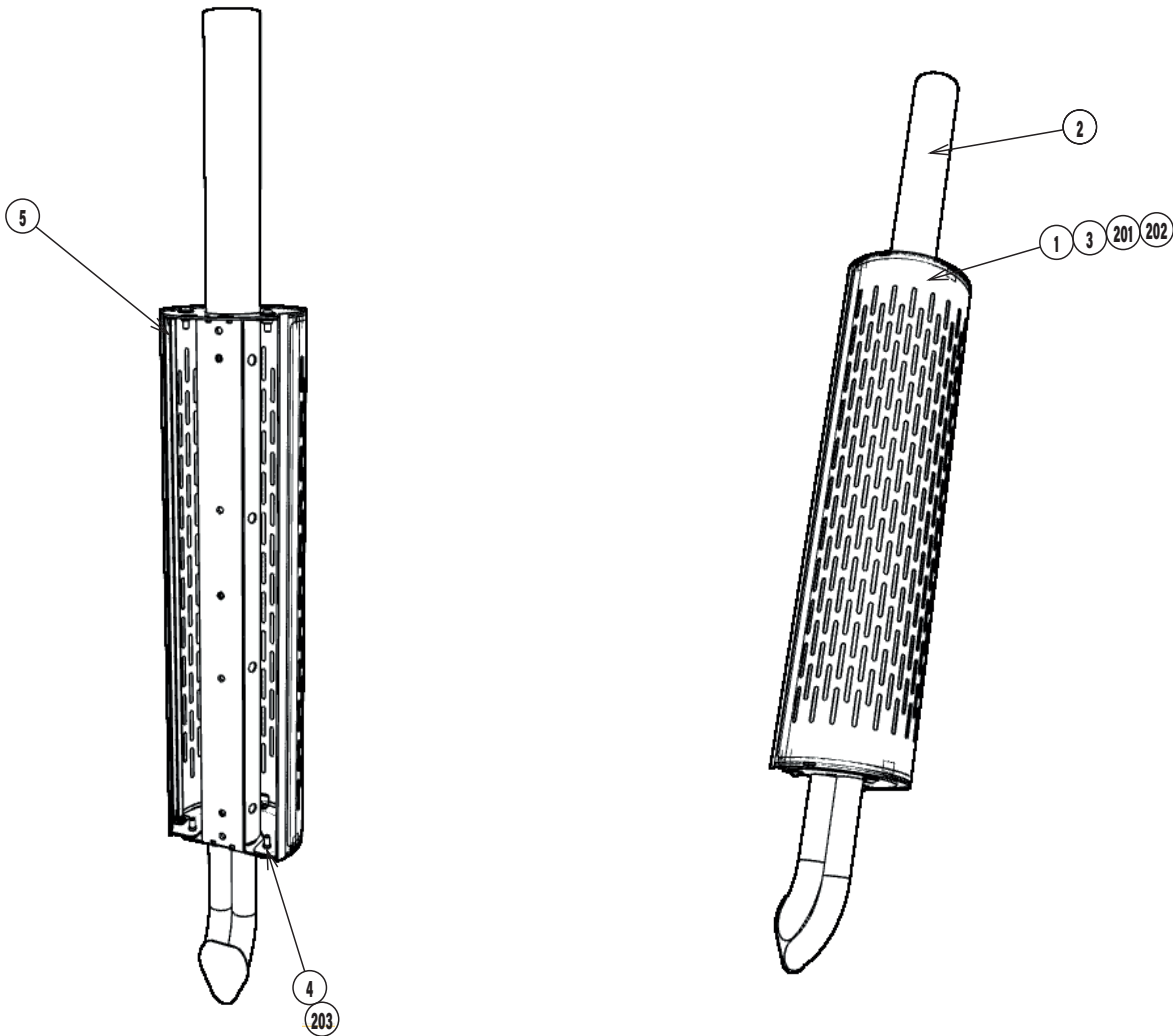

ITEM NO	PART NO	DESCRIPTION	QTY
***1	TS-0701UK	BOX EXHAUST	1
***2	TS-0702XUK	PIPE EXHAUST	1
***3	TS-0703UK	INSERT EXHAUST	1
***4	TS-0704UK	BRKT RETAIN INSERT SHORT	2
***5	TS-0705UK	BRKT RETAIN INSERT LONG	2
***101	601-0460-368-PB	CABLE TIE 368MM-4.8MM BLK NYLON	6
***201	029-B00825	M8X25 SKT BH PAS	6
***202	068-852216	M8 WSHR 22OD FLT PAS	6
***203	050-F00400	M4 NUT FLG SER PAS	6
***301	TS-6002UK	ASSY EXHAUST SERIAL	1
****101	390-2305-RGB-AD	LED FLX RGB WS2812B 6MM	1
****301	TS-60021UK	WH REAR MOULDING	1

④ ASSY LOGO LIGHT BOX (TS-0900UK)

(D-1/1)

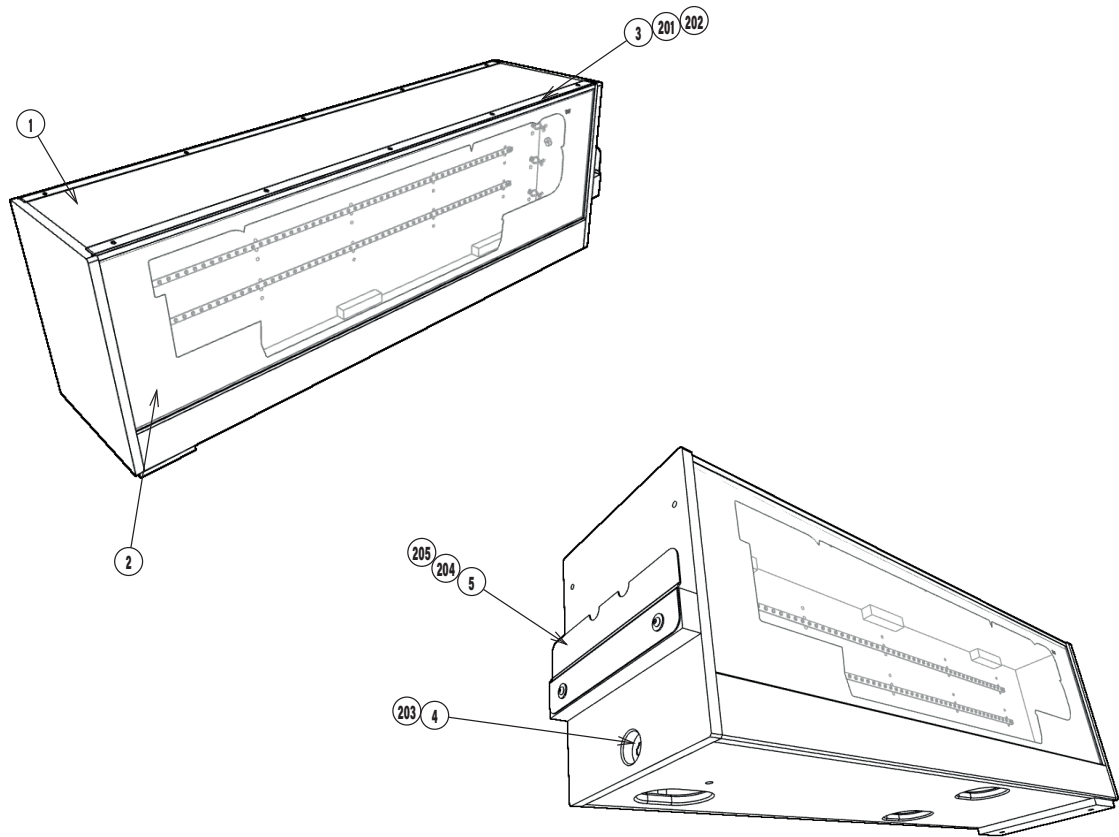

ITEM NO	PART NO	DESCRIPTION	QTY
***1	TS-0901UK	BOX LOGO LIGHT	1
***2	TS-0902UK	PANEL LOGO	2
***3	TS-0903UK	SASH LOGO PLATE	2
***4	TS-0904UK	PLATE CONN PNL	1
***5	TS-0905UK	BRKT POP SUPPORT LWR	1
***101	280-A01264-WX	ROUTER TWIST D12 SO6.4 WOOD X	6
***102	601-0460-150-N	CABLE TIE 150MM NATURAL	18
***201	029-B00416-0B	M4X16 SKT BH BLK	10
***202	068-441616-0B	M4 WSHR 16OD FLT BLK	10
***203	012-P00412-FB	N8x1/2" S/TAP FLG BLK	2
***204	029-B00640-0B	M6X40 SKT BH BLK	2
***205	068-652016-0B	M6 WSHR 20OD FLT BLK	2
***301	TS-6005UK	ASSY ROOF BOX	6
****101	390-2012-090WUK	LED RIGID WHITE 900MM	1
****301	DB-60030UK	WH LED WHT	1

④ ASSY MONITOR CABINET (TS-1000UK)

(D-1/3)

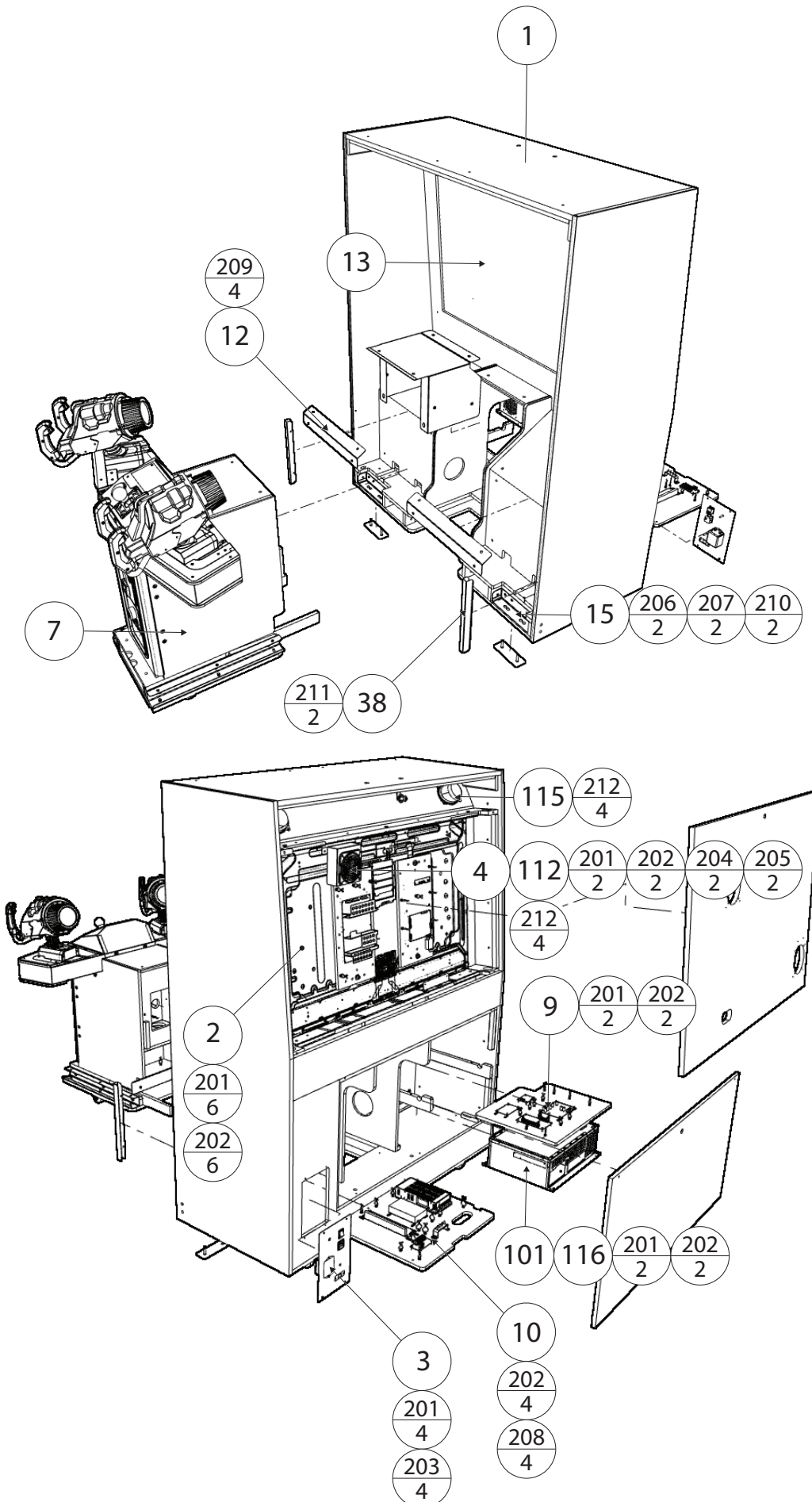

④ ASSY MONITOR CABINET (TS-1000UK)

(D-2/3)

ITEM NO	PART NO	DESCRIPTION	QTY
**1	TS-1002UK	ASSY FRONT CABINET	1
***2	TS-1002-CUK	DOOR BACK LOWER	1
***3	TS-1002-DUK	DOOR BACK UPPER	1
**2	TS-1200UK	ASSY 55 LED DISPLAY	1
**3	TS-1080UK	ASSY AC UNIT	1
**4	TRF-1340UK	ASSY 12V DC FAN	1
**7	TS-1500UK	ASSY GUN CABI	1
**9	TS-4000UK	ASSY MAIN ELEC	1
**10	TS-4100UK	ASSY PSU ELEC	1
**12	LMA-7015UK	BRKT KICK SLOPING SHELF	2
**13	TRF-1209UK	GLASS LED 55 SCREEN PROTECT	1
**15	TRF-1051UK	BRKT JOINT BRIDGE SECURE	2
**21	TS-1051UK	STICKER FRONT CABI LH SIDE	1
**22	TS-1052UK	STICKER FRONT CABI RH SIDE	1
**23	TS-1053UK	STICKER FRONT CABI LH SLOPING	1
**24	TS-1054UK	STICKER FRONT CABI RH SLOPING	1
**38	LMA-7515UK	BRKT KICK CHEEK	2
**101	610-0012-04UK	ASSY PC TS	1
**103	280-A01264-WX	ROUTER TWIST D12 SO6.4 WOOD X	8
**104	280-A02064-WX	ROUTER TWIST D20 SO6.4 WOOD X	8
**112	FN1012	FAN GUARD METAL 120MM (FG-12)	4
**115	130-04030-E	SPKR ELIP 4OHM 30W VIS DX4X6P	2
**116	LB1101	LABEL WARNING BATTERY	1
**201	029-B00425	M4X25 SKT BH PAS	22
**202	068-441616	M4 WSHR 16OD FLT PAS	16
**203	068-441616-0B	M4 WSHR 16OD FLT BLK	4
**204	029-B00412	M4X12 SKT BH PAS	2
**205	060-S00400	M4 WSHR SPR PAS	2
**206	029-B00840	M8X40 SKT BH PAS	4
**207	068-852216	M8 WSHR 22OD FLT PAS	4
**208	029-B00440	M4X40 SKT BH PAS	4
**209	029-B00825-0B	M8X25 SKT BH BLK	8
**210	060-S00800	M8 WSHR SPR PAS	4
**211	029-B00412-0B	M4X12 SKT BH BLK	4
**212	012-P00412-FB	N8x1/2" S/TAP FLG BLK	16
**301	TS-60004UK	WH AC GAMEBOARD / FLOOR	1
**302	TS-60012UK	WH SPEAKERS FRONT	1
**303	TS-60013UK	WH BASE TO FLOOR	1
**304	TS-60015UK	WH FAN	1

④ ASSY MONITOR CABINET (TS-1000UK)

(D-3/3)

ITEM NO	PART NO	DESCRIPTION	QTY
**306	TS-60024UK	WH DC DIST B	1
**312	600-7011-0200UK	DA DVI TO DVI 200CM	1
**401	029-B00840	M8X40 SKT BH PAS	4
**402	068-852216	M8 WSHR 22OD FLT PAS	4

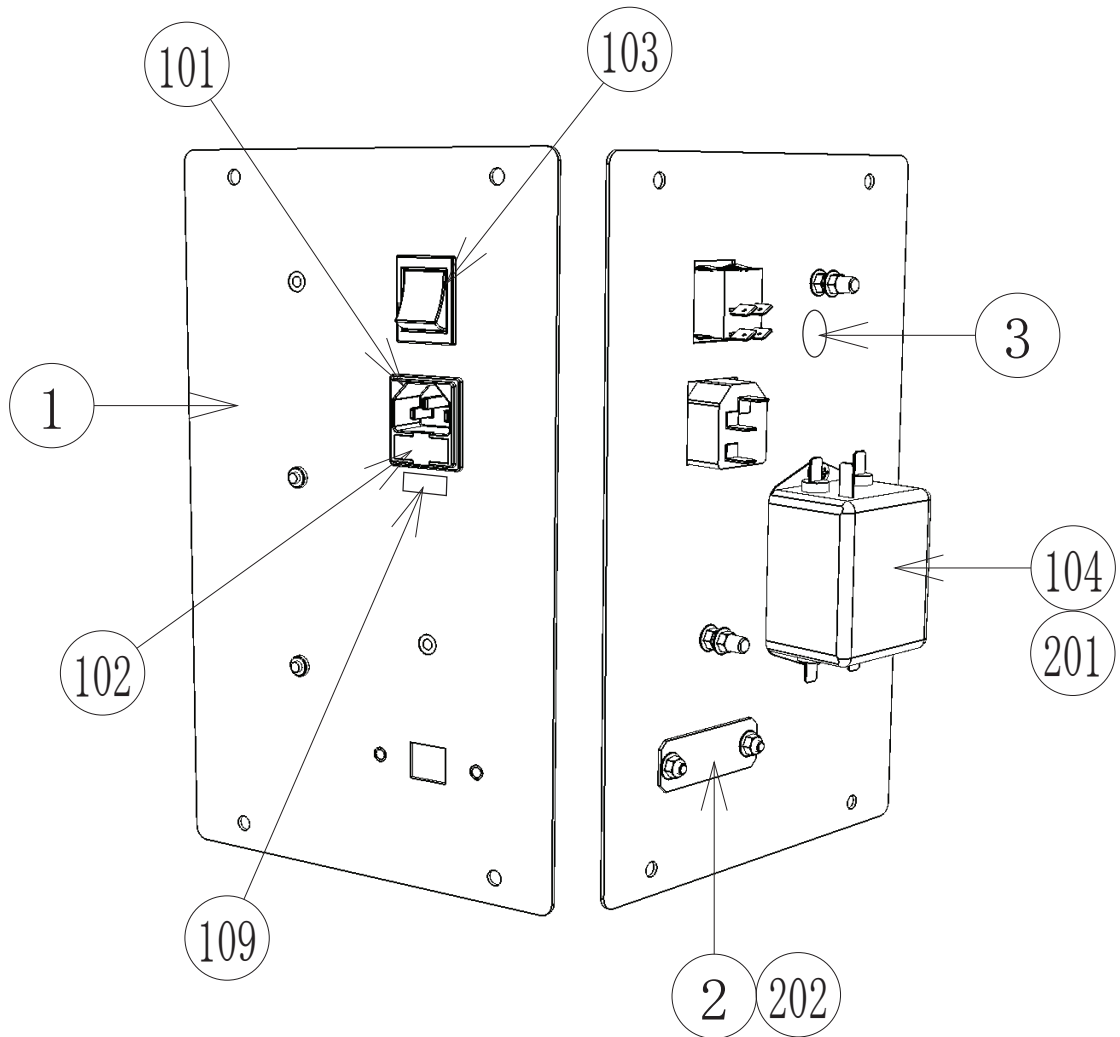

ITEM NO	PART NO	DESCRIPTION	QTY
***1	DV-1081UK	PLATE AC	1
***2	ST-0403UK	PLATE AC CAP	1
***3	LB1096	STICKER PROTECTIVE EARTH	1
***101	EP1302	EUROSOCKET FUSED 10A 250VAC	1
***102	514-5078-3150	FUSE 3.15X20 CERAMIC SB 3150mA	2
***103	SW1109	SWITCH ROCKER 250V AC	1
***104	EP1419	FILTER SCHAFFNER 2030-16-06	1
***108	310-5029-D508	HEAT SHRINK SLEEVING 50.8DIA	4
***109	LB1126-3150-250	FUSE LABEL 3.15A 250V	1
***201	029-B00408	M4X8 SKT BH PAS	2
***202	050-F00400	M4 NUT FLG SER PAS	4
***203	060-S00400	M4 WSHR SPR PAS	
***301	TS-60001UK	WH AC IN	1

⑥ ASSY 55 LED DISPLAY (TS-1200UK)

(D-1/1)

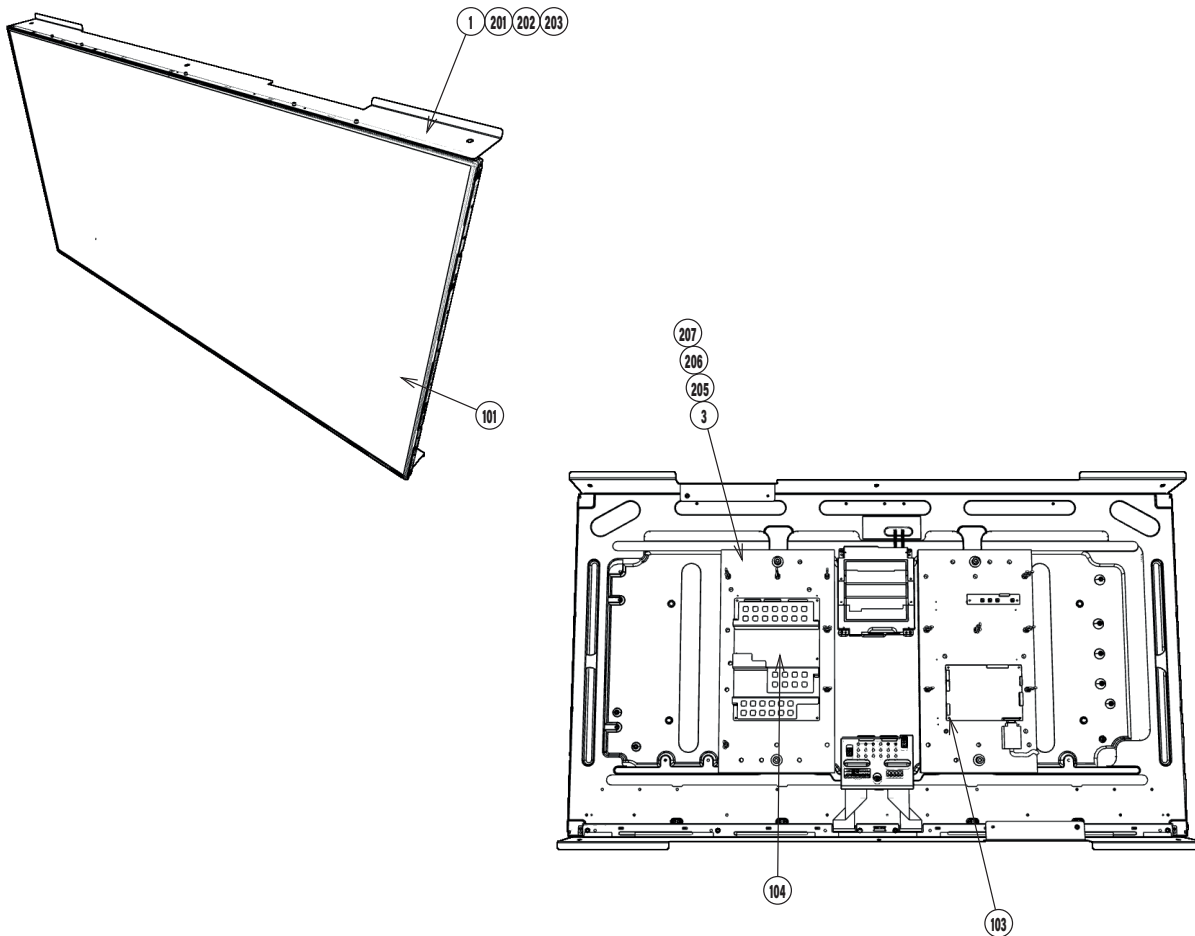

ITEM NO	PART NO	DESCRIPTION	QTY
***1	TRF-1206UK	BRKT LED MOUNT	2
***3	TRF-1210UK	PNL PRISMA BD DMODUL MNT 55	2
***101	200-6055-02-AUO	55" LED AUO P550HVN02.0	1
***102	280-A01264-WX	ROUTER TWIST D12 SO6.4 WOOD X	8
***103	280-L00811-OS	STANDOFF 7.94OD 3.56ID 11.11L	12
***104	400-283-51224	PSU 55" LED DPS-283APA-ESS5S	1
***201	020-B00308-0B	M3X8 MSCR PAN PAS	10
***202	060-S00300	M3 WSHR SPR PAS	12
***203	060-F00300	M3 WSHR FORM A FLT PAS	12
***205	020-000820-0Z	M8X20 SKT CAP OZ	4
***206	060-S00600	M8 WSHR SPR PAS	4
***207	068-652016	M8 WSHR 22OD FLT PAS	4
***208	000-P00312	M3X12 MSCR PAN PAS	2
***209	012-P00320	N4X3/4" S/TAP PAN PAS	12

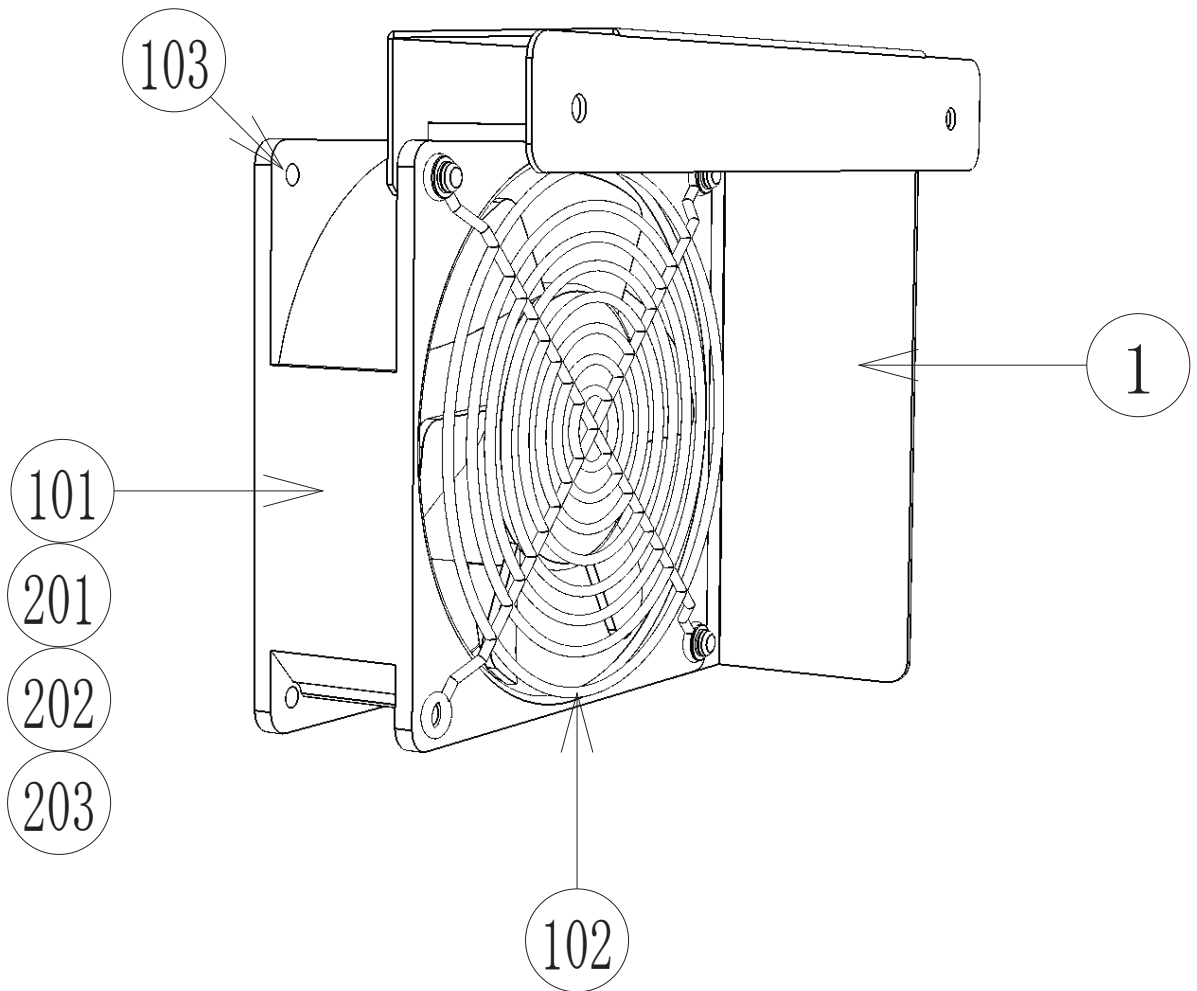

ITEM NO	PART NO	DESCRIPTION	QTY
***1	GST-1008UK	BRKT FAN	1
***101	260-0012-01UK	FAN DC 12V AXIAL	1
***102	FN1012	FAN GUARD METAL 120MM (FG-12)	2
***103	OS1195	RIVET SNAP SR-4080B	5
***201	000-P00312	M3X12 MSCR PAN PAS	3
***202	060-S00300	M3 WSHR SPR PAS	3
***203	060-F00300	M3 WSHR FORM A FLT PAS	3

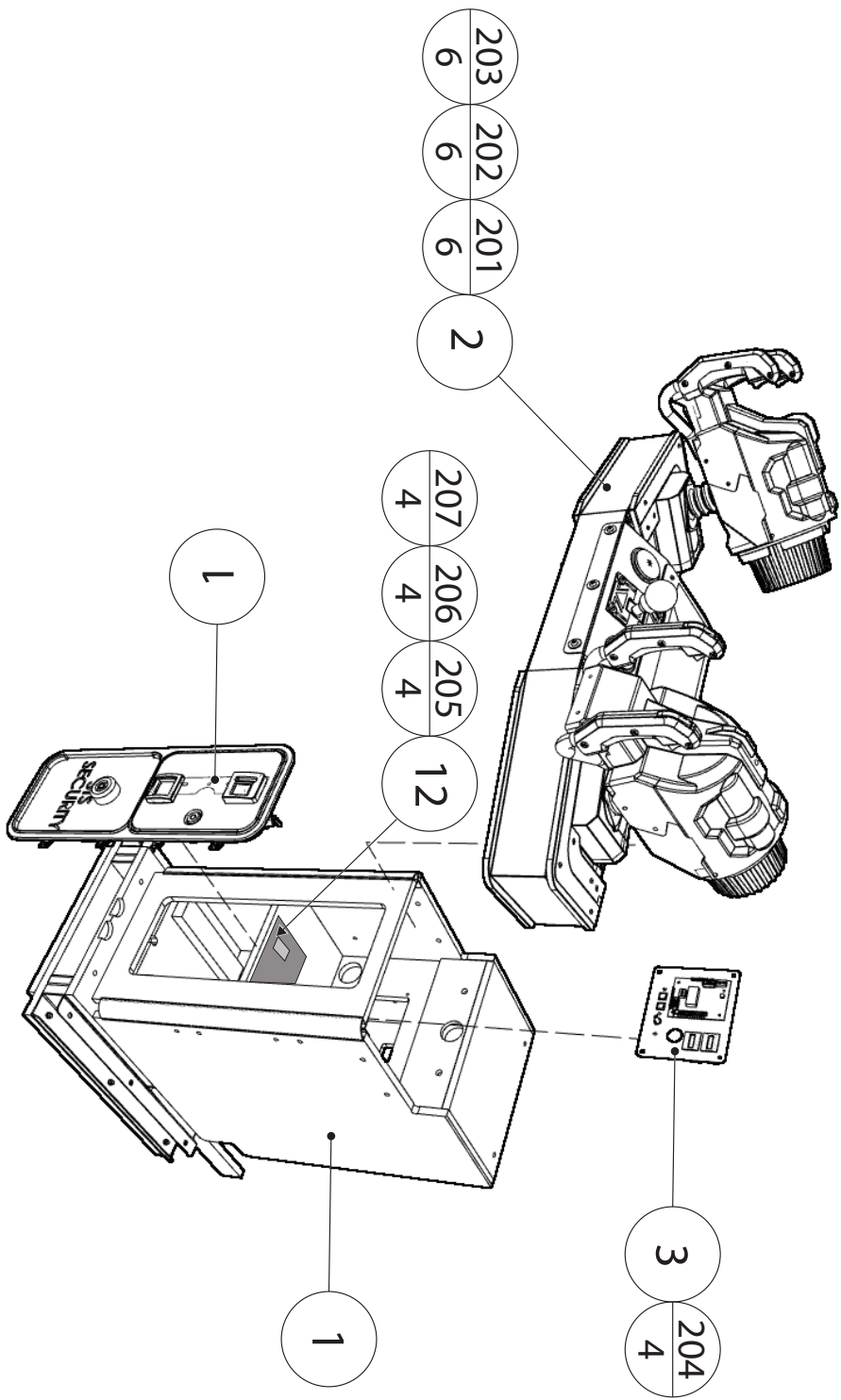

ITEM NO	PART NO	DESCRIPTION	QTY
**1	TRF-1502UK	ASSY MID CABINET	1
**2	TRF-1900UK	ASSY CTRL BOX	1
**3	DV-3850UK	ASSY SW UNIT	1
**4	TRF-0003UK	BRKT JOINT BRIDGE SECURE	2
**5	TRF-1003UK	BRKT CORNER JOINT TOP	2
**6	TRF-1511UK	PLATE AUTOBOT	1
**7	TRF-1512UK	BRKT MTG PLATE AUTOBOT	1
**8	TRF-1513UK	BRKT MTG CONPANE COVER	6
**9	TRF-1514UK	PLATE JOINT LOWER MON GUN CABI	2
**10	TRF-1515UK	BRKT KICK CHEEK	2
**11	601-12955-001	CONPANE COVER UL-HB	1
**12	DUT-0302UK	COIN PATH PLATE	1
**13	PP1087	BOX CASH FOR MINI DOOR	1
**14	LGI-0304UK	LOCKING HASP	1
**15	LGI-0305UK	BRKT PADLOCK	1
**16	TRF-1516UK	COVER FOOTWELL LIGHT	2
**17	TRF-1517UK	BRKT PNL MNT	1
**21	TRF-1551UK	STICKER MID CABI LH SIDE	1
**22	TRF-1552UK	STICKER MID CABI RH SIDE	1
**23	TRF-1553UK	STICKER CTRL BOX L	1
**24	TRF-1554UK	STICKER CTRL BOX R	1
**25	TRF-1913UK	STICKER PLAY INSTR	1
**101	509-0001-BL	BTN 12V 1.2W BLU S'POINT CPBL	1
**102	509-0001-RE	BTN 12V 1.2W BLU S'POINT CPBL	1
**201	020-F00830-0B	M8X30 SKT CSK BLK	12
**202	030-000830	M8X30 BLT PAS	12
**203	060-S00800	M8 WSHR SPR PAS	12
**204	068-852216	M8 WSHR 220D FLT PAS	12
**205	000-P00420	M4X20 MSCR PAN PAS	25
**206	060-S00400	M4 WSHR SPR PAS	21
**207	060-F00400	M4 WSHR FORM A FLT PAS	21
**208	029-B00412-0B	M4X12 SKT BH BLK	18
**209	060-S00400-0B	M4 WSHR SPR BLK	18
**210	068-441616-0B	M4 WSHR 16OD FLT BLK	18
**211	050-U00800	M8 NUT NYLOK PAS	8
**212	060-F00800	M8 WSHR FORM A FLT PAS	8
**301	TRF-60004UK	WH REAR SPKR EXTN	1
**302	TRF-60011UK	WH COIN HANDLING	1
**303	TRF-60012UK	WH CTRL PNL BUTTONS ILLUM	1
**304	TRF-60015UK	WH DBA	1
**305	TRF-60017UK	WH FLOOR ASSY	1
**306	390-2012-RGB	LED FLX STRIP RGB 5MTR	1.3
**307	BE-6001UK	WH LED CLIP	3
**308	LM1006LOR	LOOM COIN MECH LAMP	1

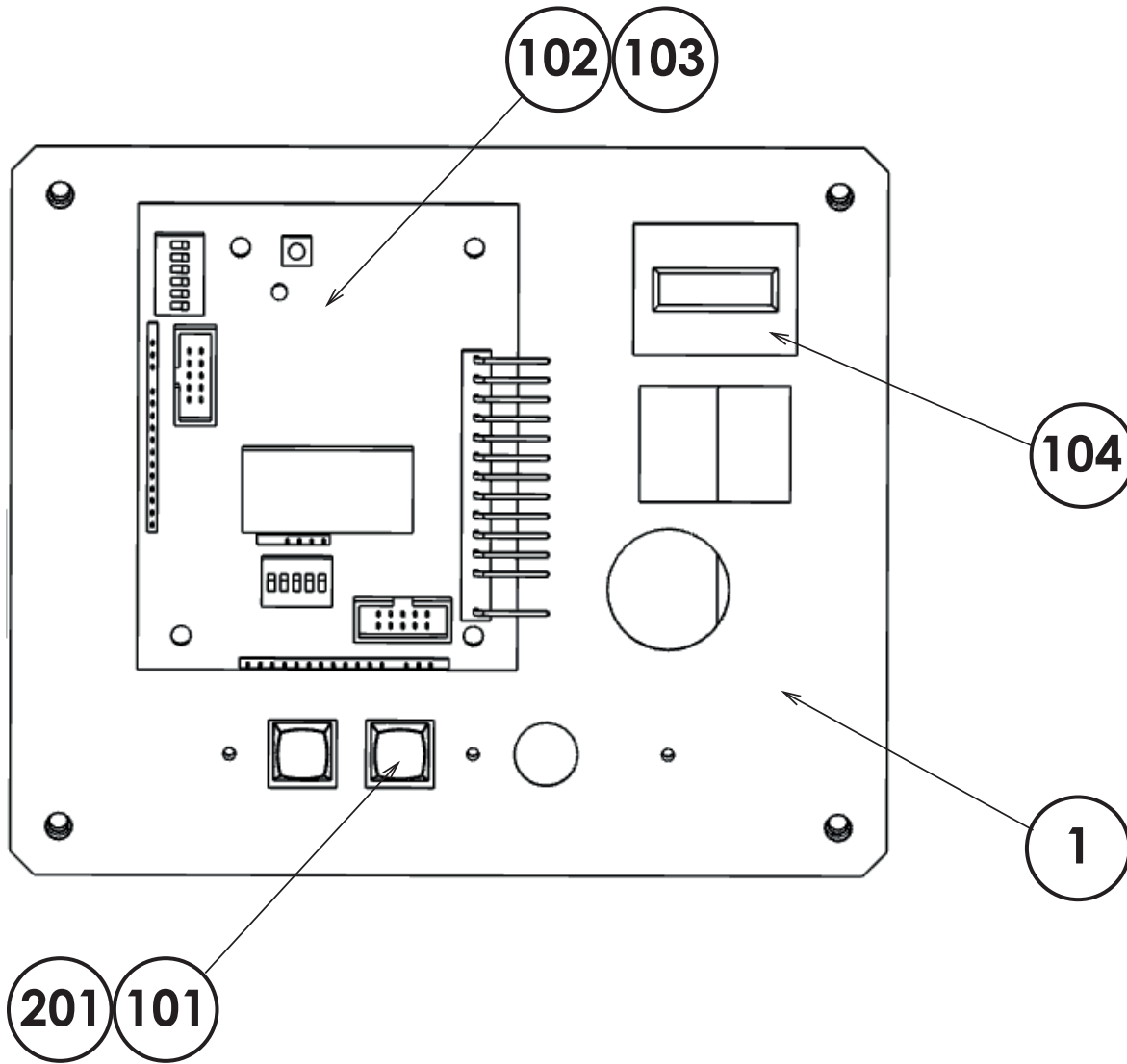

ITEM NO	PART NO	DESCRIPTION	QTY
***1	SSR-0321UK	SW BRKT DOUBLE METER	1
***101	838-14548-01AUK	SW & VOL CTL BD	1
***102	280-L00706-PM	STANDOFF 6.4MM HOLE PM	4
***103	EP1380-01	CREDIT BOARD EXCEL	1
***104	220-5643UK	COIN METER SMALL 12V	1
***106	421-12043-01	STICKER SW PANEL CE	1
***107	OS1098	CRIMP BELL END SMALL	2
***108	601-0460	CABLE TIE NYLON 100MM	2
***201	029-B00308	M3X8 SKT BH PAS	3
***301	DA-60110	WH COIN HANDLING	1

10 ASSY CTRL BOX (TS-1900UK)

(D-1/2)

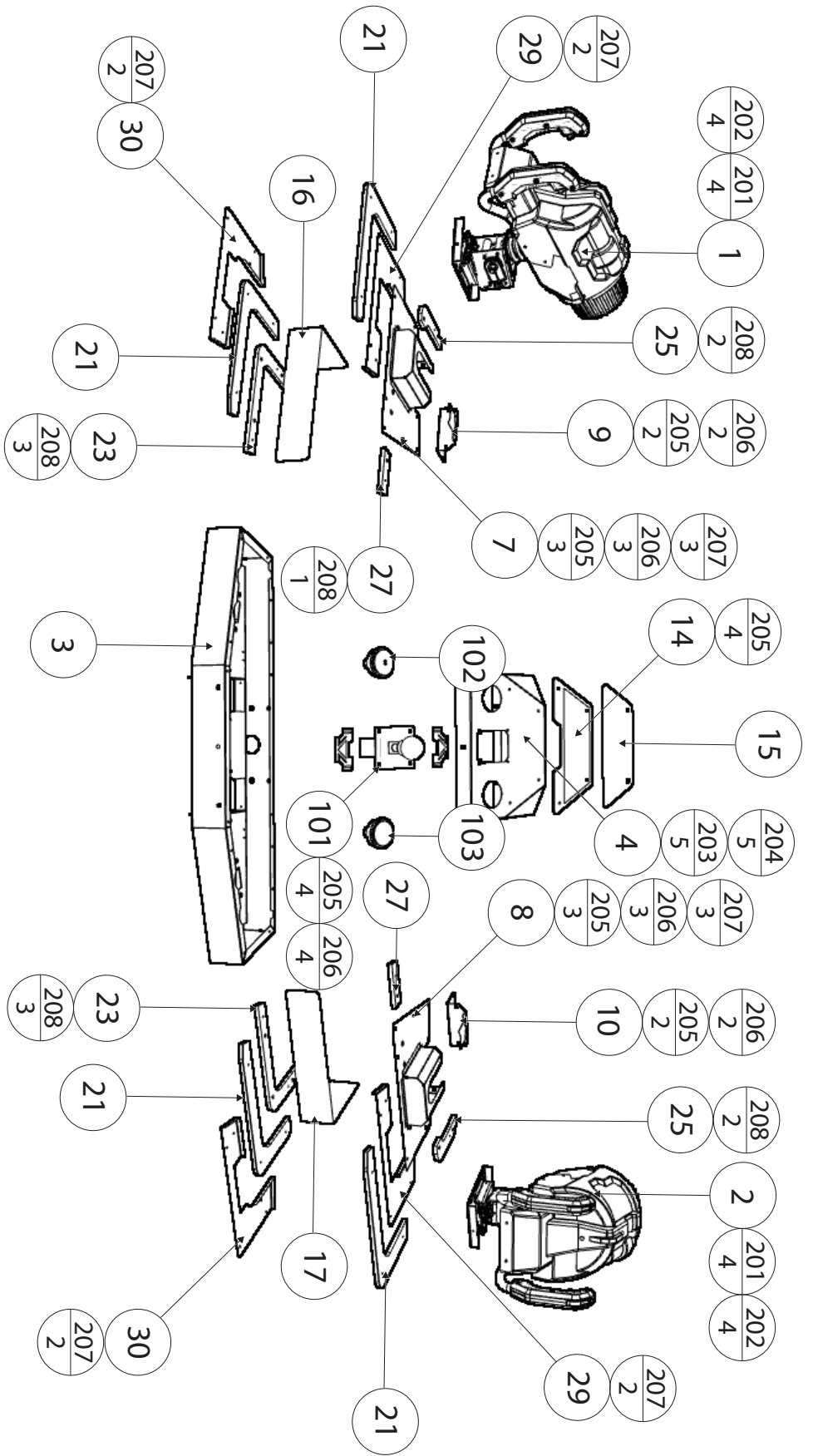

10 ASSY CTRL BOX (TS-1900UK)

(D-2/2)

ITEM NO	PART NO	DESCRIPTION	QTY
***1	TS-2000UK	ASSY CONTROLLER L	1
***2	TS-2050UK	ASSY CONTROLLER R	1
***3	TS-1901UK	CTRL PNL UNDER	1
***4	TS-1902UK	CTRL PNL CTRL COVER	2
***7	TS-1905UK	LID CTRL FRONT L	1
***8	TS-1906UK	LID CTRL FRONT R	2
***9	TRF-1907UK	LID CTRL REAR L	1
***10	TRF-1908UK	LID CTRL REAR R	1
***14	TS-1913UK	PLATE COVER INST	1
***21	TS-1921UK	PLATE LED EDGE LIT	2
***23	TS-1923UK	BASE LED LGHT FULL	1
***25	TS-1925UK	BASE LED LGHT SHORT OUTER	2
***27	TS-1927UK	BASE LED LGHT SHORT INNER	8
***29	TS-1929UK	COVER LED LTOP RBTM	8
***30	TS-1930UK	COVER LED RTOP LBTM	30
***101	610-2102-01UK	UP/DOWN SHIFTER W/LED	1
***102	509-0001-BL	BTN 12V 1.2W BLU S'POINT CPBL	1
***103	509-0001-RE	BTN 12V 1.2W RED S'POINT CPBL	1
***201	029-B00816	M8X16 SKT BH PAS	8
***202	060-S00800	M8 WSHR SPR PAS	8
***203	029-B00612-0B	M6X12 SKT BH BLK	5
***204	068-652016-0B	M6 WSHR 20OD FLT BLK	5
***205	029-B00412-0B	M4X12 SKT BH BLK	18
***206	068-441616-0B	M4 WSHR 16OD FLT BLK	14
***207	029-B00416-0B	M4X16 SKT BH BLK	14
***208	000-F00416	M4X16 MSCR CSK PAS	12
***301	TS-60009UK	WH CONTROLLERS	1
***302	TS-60010UK	WH START BUTTONS	1
***303	TS-60027UK	WH CTRL PANEL LIGHTING	1
***304	BE-6001UK	ASSY LED CLIP	4
***401	RND-0292	A/W UP/DOWN SHIFTER W/LED TS	2

18

PARTS LIST

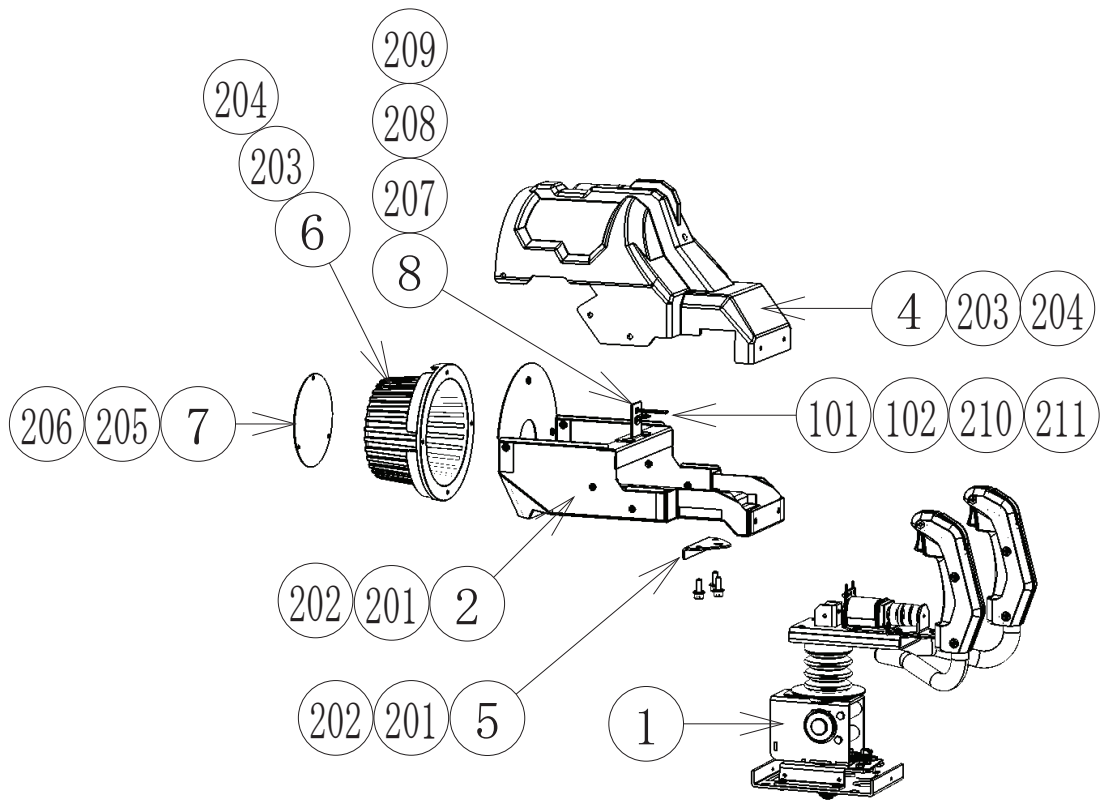

ITEM NO	PART NO	DESCRIPTION	QTY
***1	TS-2001-02UK	CONT CHASSIS W/DUAL SOL	1
***2	TS-2002UK	BASE GUN W/DUAL SOL	1
***4	601-12955-002	GUN COVER	1
***5	TS-2005UK	BRKT MTG BASE GUN	1
***6	601-12955-005	GUN MUZZLE COVER UL-HB	1
***7	TRF-2006UK	PLATE MUZZLE CLOSING	1
***8	TRF-2007UK	BRKT LIGHT MTG INTERNAL	1
***101	601-12955-008	GUN UPPER LED 1P RED	1
***102	280-L00605-OS	STANDOFF 6.35OD 3.56ID 4.76L	1
***201	020-000616-OZ	M6X16 SKT CAP OZ	5
***202	060-S00600	M6 WSHR SPR PAS	5
***203	060-F00600	M6 WSHR FORM A FLT PAS	5
***204	008-OS0412	M4X12 TMP PRF STN	12
***205	000-P00408	M4X8 MSCR PAN PAS	3
***206	060-S00400	M4 WSHR SPR PAS	3
***207	000-P00412	M4X12 MSCR PAN PAS	2
***208	060-S00400	M4 WSHR SPR PAS	2
***209	060-F00400	M4 WSHR FORM A FLT PAS	2
***210	000-P00312	M3X12 MSCR PAN PAS	1
***211	068-330808-PN	M3 WSHR 8OD FLT NYLON	1
***301	TRF-60020UK	WH GUN ILLUMINATION	1

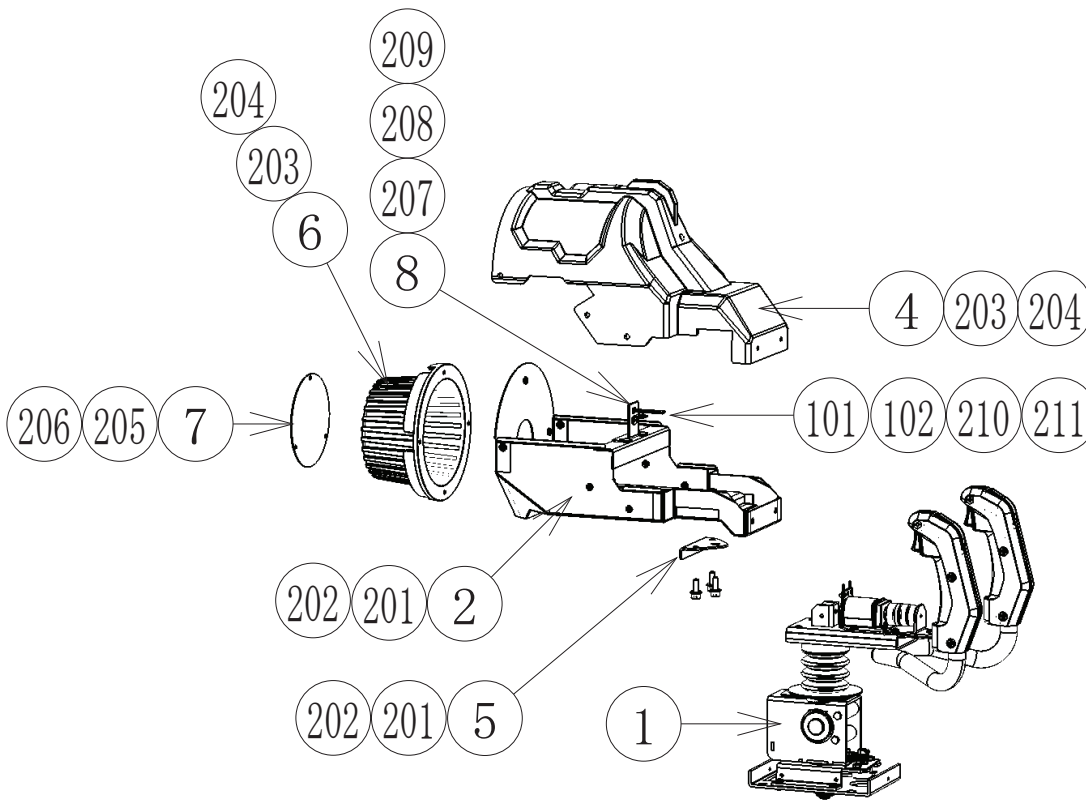

ITEM NO	PART NO	DESCRIPTION	QTY
***1	TS-2001-01UK	CONT CHASSIS W/DUAL SOL	1
***2	TS-2002UK	BASE GUN W/DUAL SOL	1
***4	601-12955-002	GUN COVER	1
***5	TS2005UK	BRKT MTG BASE GUN	1
***6	601-12955-005	GUN MUZZLE COVER UL-HB	1
***7	TRF-2006UK	PLATE MUZZLE CLOSING	1
***8	TRF-2007UK	BRKT LIGHT MTG INTERNAL	1
***101	601-12955-009	GUN UPPER LED 2P BLUE	1
***102	280-L00605-OS	STANDOFF 6.35OD 3.56ID 4.76L	1
***201	020-000616-OZ	M6X16 SKT CAP OZ	5
***202	060-S00600	M6 WSHR SPR PAS	5
***203	060-F00600	M6 WSHR FORM A FLT PAS	5
***204	008-OS0412	M4X12 TMP PRF STN	12
***205	000-P00408	M4X8 MSCR PAN PAS	3
***206	060-S00400	M4 WSHR SPR PAS	3
***207	000-P00412	M4X12 MSCR PAN PAS	2
***208	060-S00400	M4 WSHR SPR PAS	2
***209	060-F00400	M4 WSHR FORM A FLT PAS	2
***210	000-P00312	M3X12 MSCR PAN PAS	1
***211	068-330808-PN	M3 WSHR 8OD FLT NYLON	1
***301	TRF-60020UK	WH GUN ILLUMINATION	1

13 ASSY REAR CABINET (TS-3000UK)

(D-1/3)

18 PARTS LIST

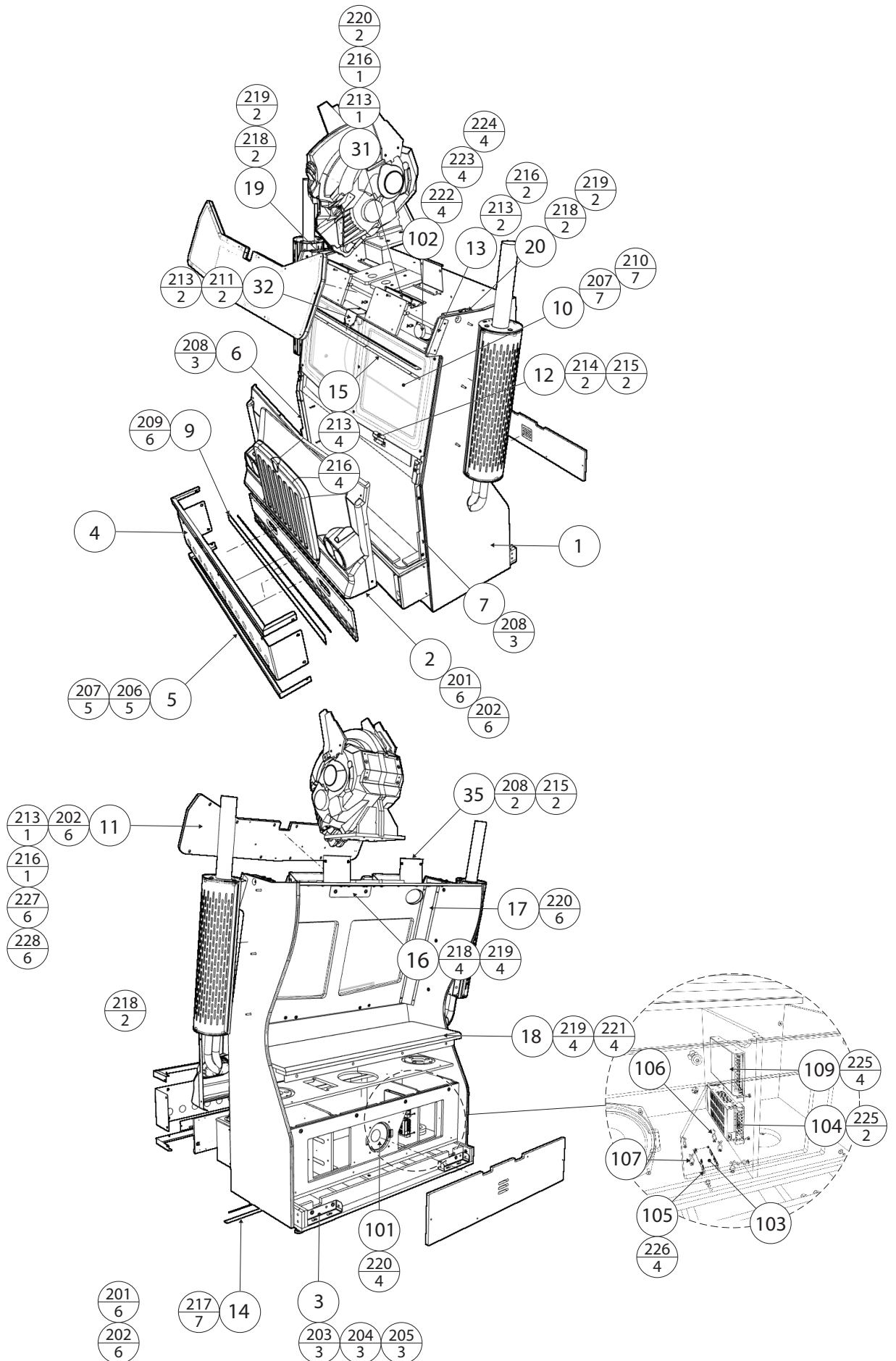

ITEM NO	PART NO	DESCRIPTION	QTY
**1	TS-3002UK	ASSY REAR CABINET	1
**2	TS-3002-BUK	DOOR SEAT LOWER	1
**2	TS-3700UK	ASSY REAR MOULDING	1
**3	TS-0003UK	BRKT JOINT BRIDGE SECURE	2
**4	TS-3003UK	FENDER MAIN	1
**5	TS-3004UK	FENDER SASH	2
**6	TS-3005UK	BRKT SECURE VAC INNER L	1
**7	TS-3006UK	BRKT SECURE VAC INNER R	1
**9	TS-3008UK	COVER LED FENDER FRONT	1
**10	TS-3009UK	REAR WINDOW	1
**11	TS-3900UK	ASSY VISOR LIGHT BOX	2
**12	TS-3011UK	BRKT SECURE VAC UPPER	2
**13	TS-3012UK	BRKT SECURE VISOR	2
**14	TS-3013UK	COVER LED FENDER DOWNLIGHT	1
**15	TS-3014UK	BRKT RETAIN WINDOW UPPER	1
**16	TS-3015UK	BRKT SUPP BILLBOARD	1
**17	TS-3016UK	BRKT CONDUIT	1
**18	TS-3600UK	ASSY SEAT BTM	1
**19	TS-3017UK	BRKT SECURE EXHAUST TOP L	1
**20	TS-3018UK	BRKT SECURE EXHAUST TOP R	
**21	TS-3551UK	STICKER REAR CABI LH SIDE	1
**22	TS-3552UK	STICKER REAR CABI RH SIDE	1
**23	TS-3553UK	STICKER REAR CABI LH UPPER	1
**24	TS-3554UK	STICKER REAR CABI RH UPPER	1
**31	TS-3800UK	ASSY UPLIGHT OP HEAD	2
**32	TS-3019UK	BRKT SECURE VISOR UNDER	1
		t	
**35	TS-0007UK	BRKT SUPPORT SHOULDER	2
**101	130-020-04080	SPEAKER 4 OHM 80W WS 20E	1
**102	130-04030-E	SPKR ELIP 4OHM 30W VIS DX4X6P	2
**103	838-0041UK	PCBA - WOOFLY2	1
**104	400-150-05-03	PSU 5V DC 150W MW RS-150-05	1
**105	OS1011	PCB FEET RICHCO LCBS-L-5-01	4
**106	280-A01264-WX	ROUTER TWIST D12 SO6.4 WOOD X	20
**107	280-A02064-WX	ROUTER TWIST D20 SO6.4 WOOD X	1
**108	OS1098	CRIMP BELL END SMALL	2
**109	400-200-012-03	PSU 12VDC 200W RSP-200-12	1
**201	029-B00616	M6X16 SKT BH PAS	6
**202	068-652016	M6 WSHR 20OD FLT PAS	12
**203	029-B00840	M8X40 SKT BH PAS	4
**204	068-852216	M8 WSHR 22OD FLT PAS	4
**205	060-S00800	M8 WSHR SPR PAS	4
**206	029-B00425	M4X25 SKT BH PAS	10
**207	068-441616	M4 WSHR 16OD FLT PAS	17

**208	029-B00625-0B	M6X25 SKT BH BLK	10
**209	012-P03512-F	N6X1/2" S/TAP FLG PAS	6
**210	029-B00412	M4X12 SKT BH PAS	7
**211	029-B00408-0B	M4X8 SKT BH BLK	2
**213	068-441616-0B	M4 WSHR 16OD FLT BLK	13
**214	029-B00640-0B	M6X40 SKT BH BLK	4
**215	068-652016-0B	M6 WSHR 20OD FLT BLK	10
**216	029-B00425-0B	M4X25 SKT BH BLK	11
**217	012-P03506-F	N6X1/4" S/TAP FLG PAS	14
**218	029-B00825-0B	M8X25 SKT BH BLK	8
**219	068-852216-0B	M8 WSHR 22OD FLT BLK	12
**220	012-P00412-FB	N8x1/2" S/TAP FLG BLK	18
**221	029-B00840-0B	M8X40 SKT BH BLK	4
**222	000-F00425	M4X25 MSCR CSK PAS	4
**223	060-F00400	M4 WSHR FORM A FLT PAS	4
**224	050-U00400	M4 NUT NYLOK PAS	4
**225	000-F00420	M4X20 MSCR CSK PAS	6
**226	012-P03512-F	N6X1/2" S/TAP FLG PAS	4
**227	029-B00625	M6X25 SKT BH PAS	6
**228	020-F00640-0B	M6X40 SKT CSK BLK	2
**301	TS-6001UK	ASSY LOWER BUMPER SERIAL	1
****101	390-2305-RGB-AD	LED FLX RGB WS2812B 6MM	1
****301	TS-60022UK	WH REAR CAB SERIAL	1
**302	TS-60016UK	WH AC REAR	1
**303	TS-60017UK	WH REAR CAB	1
**304	TS-60018UK	WH REAR SPEAKERS	1
**305	TS-60019UK	WH UPPER RGB EXTN	1
**307	TS-60025UK	WH HEAD UPLIGHT	1
**308	TS-60026UK	WH REAR CAB UPPER	1
**309	BE-6001UK	ASSY LED CLIP	2
**310	TS-60028UK	WH WOOFER	1
**311	TS-60029UK	WH WOOFER/SHAKER	1
**312	TS-60030UK	WH PSU LINK	1
**313	TS-60031UK	WH DC OUT REAR A	1
**314	TS-60032UK	WH DC OUT REAR B	1
**401	RND-0291	BRKT SEAT TRANSIT TS	2
**402	029-B00825	M8X25 SKT BH PAS	2
**403	068-852216	M8 WSHR 22OD FLT PAS	4
**404	050-F00800	M8 NUT FLG SER PAS	2
**405	029-B00640	M6X40 SKT BH PAS	2
**406	068-652016	M6 WSHR 20OD FLT PAS	2
**407	RND-0300	BRKT ANTI-TILT SEAT TRANSIT TS	1
**408	MA1007	CASTOR SWIVEL 63MM NYLON	1

14 ASSY SEAT BTM (TS-3600UK)

(D-1/1)

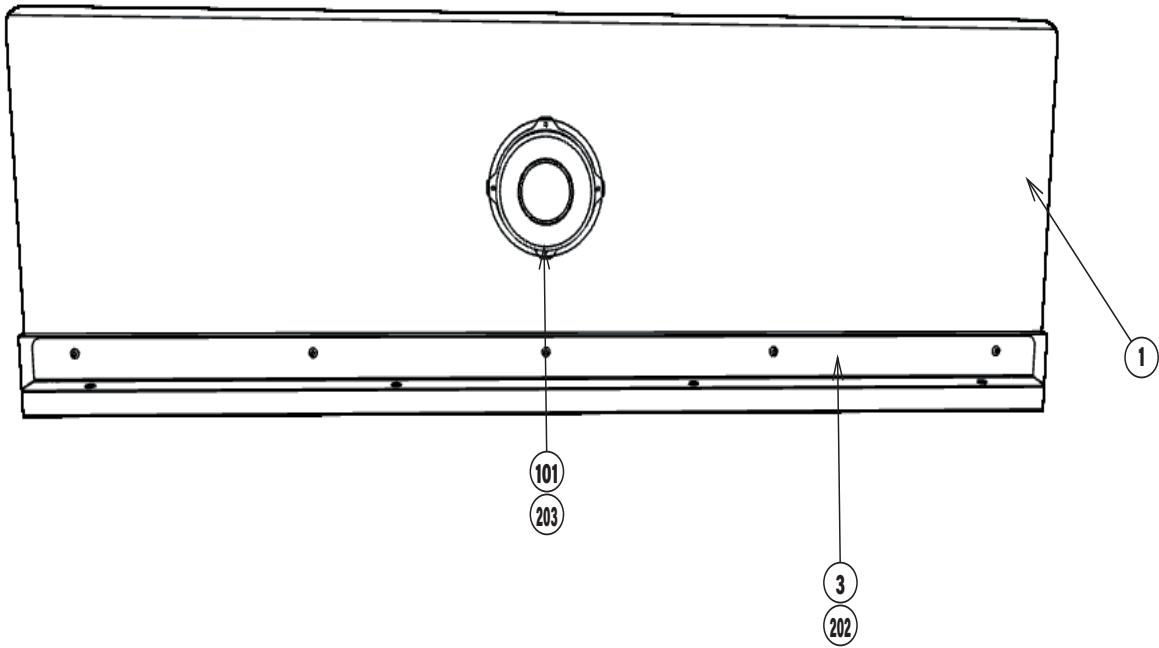

ITEM NO	PART NO	DESCRIPTION	QTY
***1	TS-3601UK	ASSY SEAT WOOD	1
****1	TS-3601-AUK	SEAT WOOD	1
***3	TS-3603UK	SEAT FIX BRKT	1
***101	130-04050-BSX	BASS SHAKER 4OHM 50W BSX 130 WP	1
***202	029-B00625-0B	M6X25 SKT BH BLK	5
***203	012-P00412-FB	N8x1/2" S/TAP FLG BLK	4

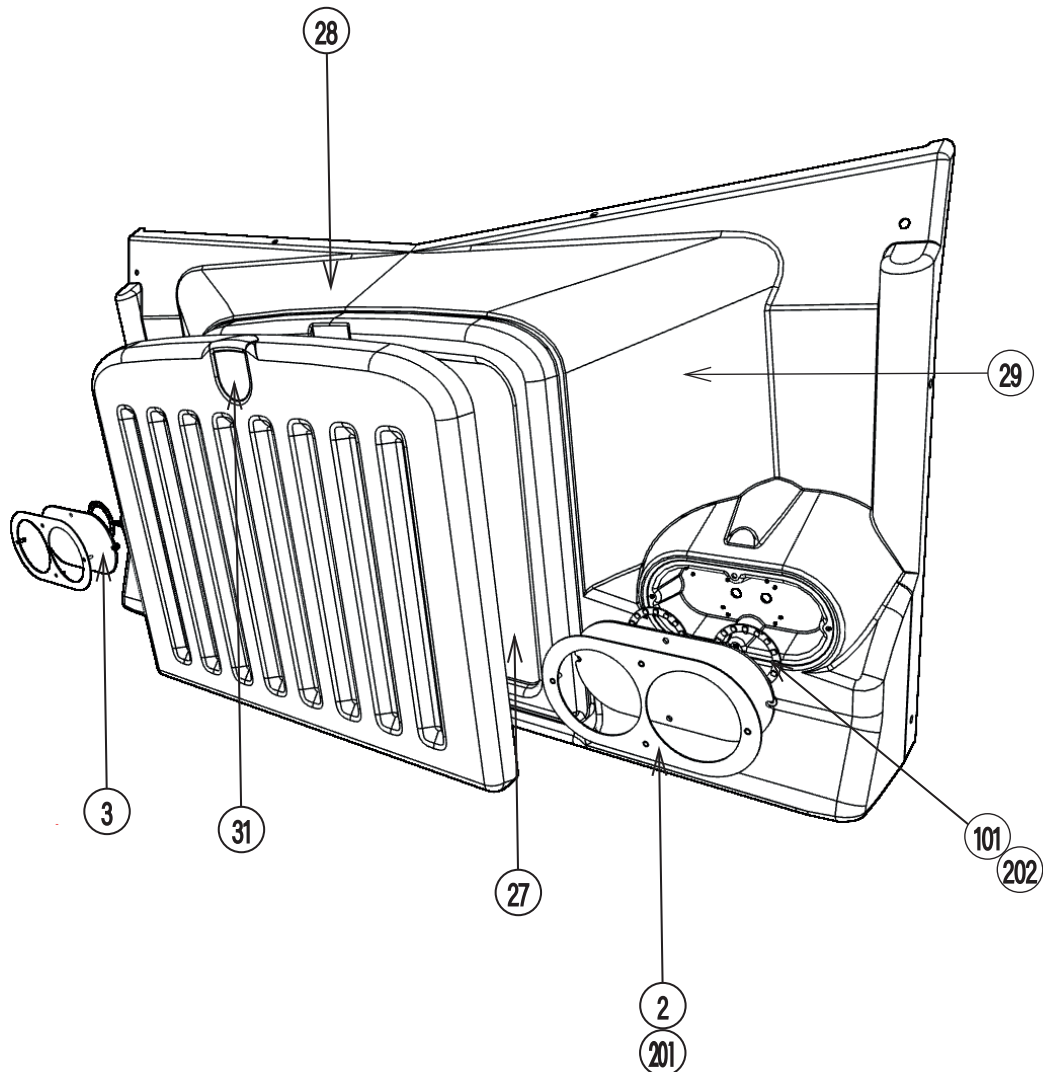

ITEM NO	PART NO	DESCRIPTION	QTY
***2	TS-3702UK	PLATE HEADLIGHT COVER	2
***3	TS-3703UK	DIFFUSER HEADLIGHT COVER	2
***27	TS-3711UK	TRUCK RADIATOR FLAT	1
***28	TS-3713UK	DECAL FLAMES L	1
***29	TS-3714UK	DECAL FLAMES R	1
***31	TS-3716UK	DECAL BADGE RADIATOR SEGA	1
***101	390-2505-072-AD	SLED RING 072 M7216WS2812B	4
***102	OS1247	ALUMINIUM STICKY CLIP ASK-3	3
***201	OS-F00400	M4 NUT FLG SER PAS	8
***202	601-0460	CABLE TIE 100MM	12
***301	TS-6002UK	WH REAR MOULDING	1

①⑥ ASSY UPLIGHT OP HEAD (TS-3800UK)

(D-1/1)

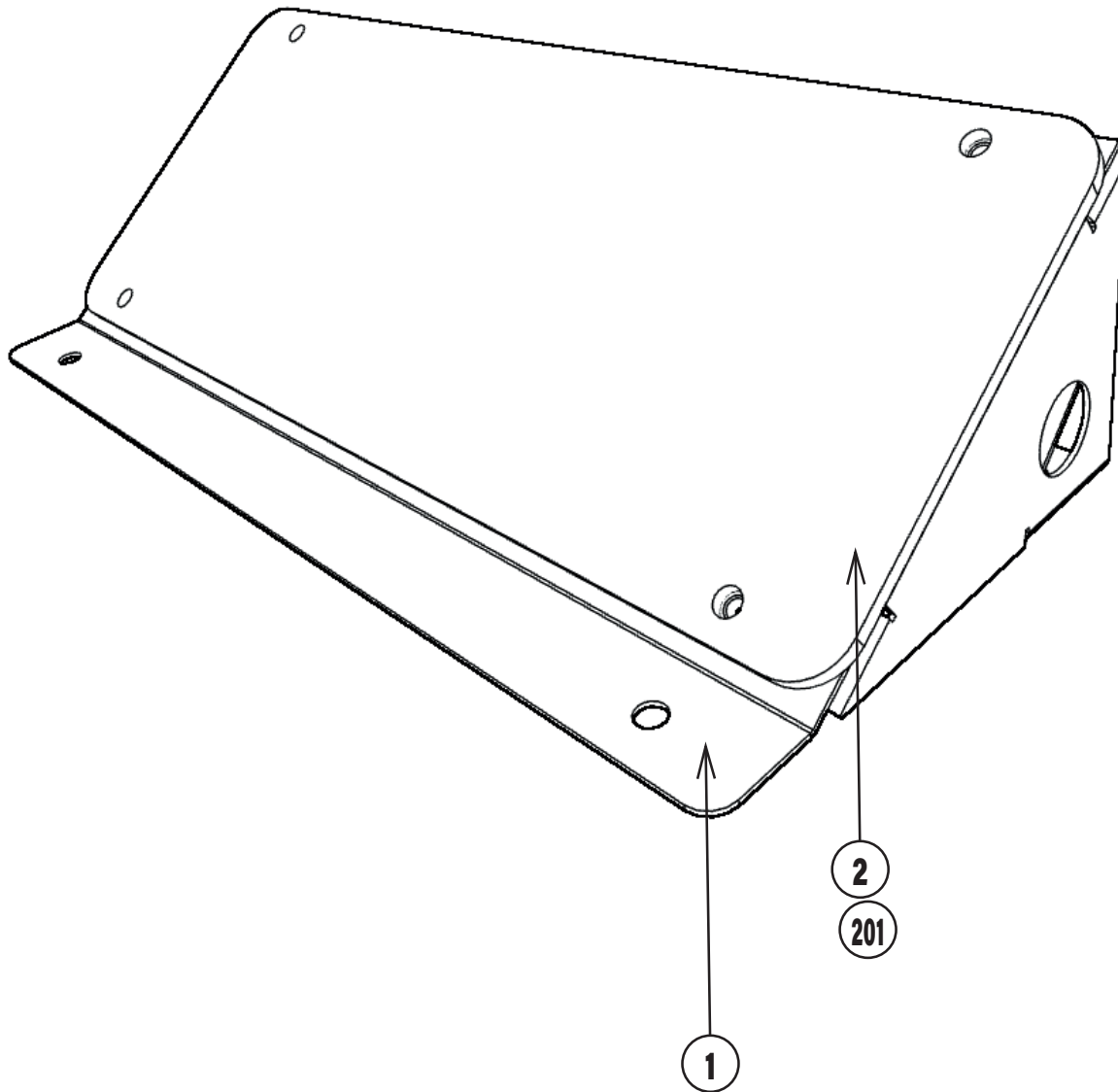

ITEM NO	PART NO	DESCRIPTION	QTY
***1	TS-3801UK	BRKT BASE UPLIGHT	1
***2	TS-3802UK	COVER BASE UPLIGHT	1
***101	601-0460	CABLE TIE 100MM	3
***201	029-B00408	M4X8 SKT BH PAS	4
***301	TS-6004UK	ASSY UPLIGHT RIGID WHITE	1

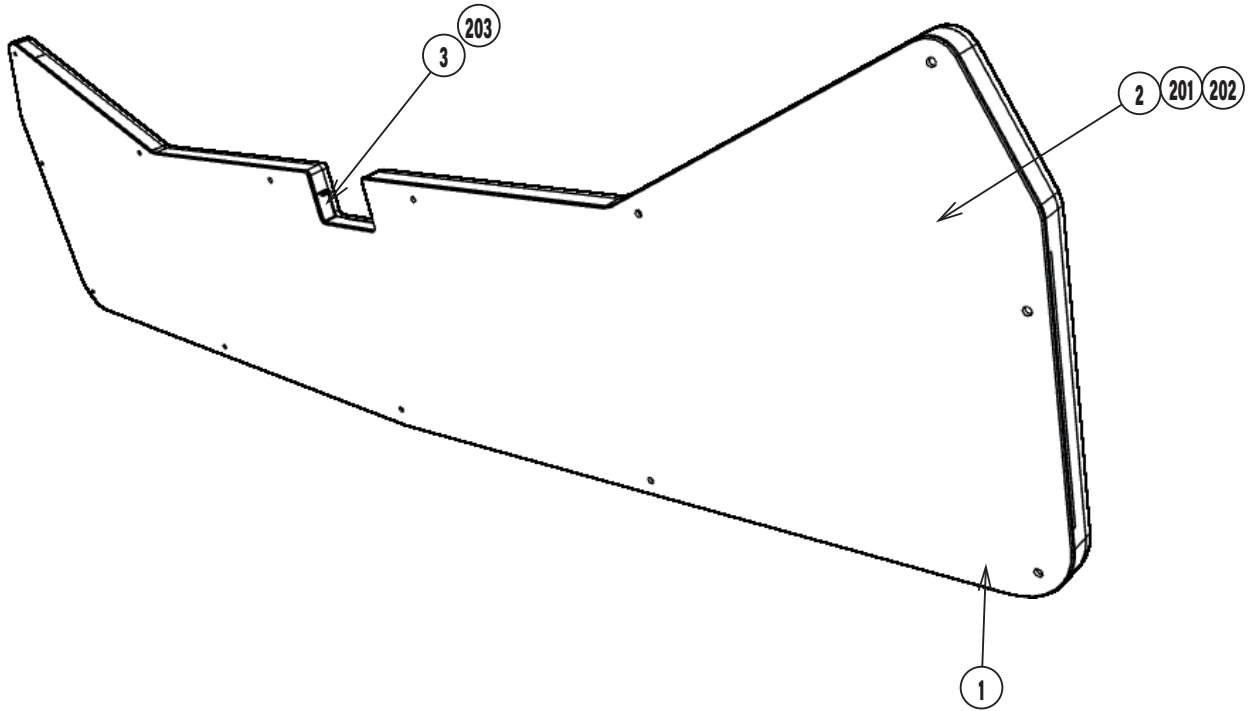

ITEM NO	PART NO	DESCRIPTION	QTY
***1	TS-3901UK	BOX VISOR LIGHT	1
***2	TS-3902UK	PANEL VISOR	1
***3	TS-3903UK	BRKT CHIN CLOSING	1
***101	280-A01264-WX	ROUTER TWIST D12 SO6.4 WOOD X	6
***102	601-0460-150-N	CABLE TIE 150MM NATURAL	18
***201	029-B00412-0B	M4X12 SKT BH BLK	12
***202	068-441616-0B	M4 WSHR 16OD FLT BLK	12
***203	012-P03506-F	N6X1/4" S/TAP FLG PAS	3
***301	TS-6006UK	ASSY VISOR UPPER	1
****101	390-2012-090WUK	LED RIGID WHITE 900MM	2
****301	TS-60034UK	WH LED WHT	1
***302	TS-6006UK	ASSY VISOR LOWER	1
****101	390-2012-135WUK	LED RIGID WHITE 1350MM	1
****301	TS-60034UK	WH LED WHT	1

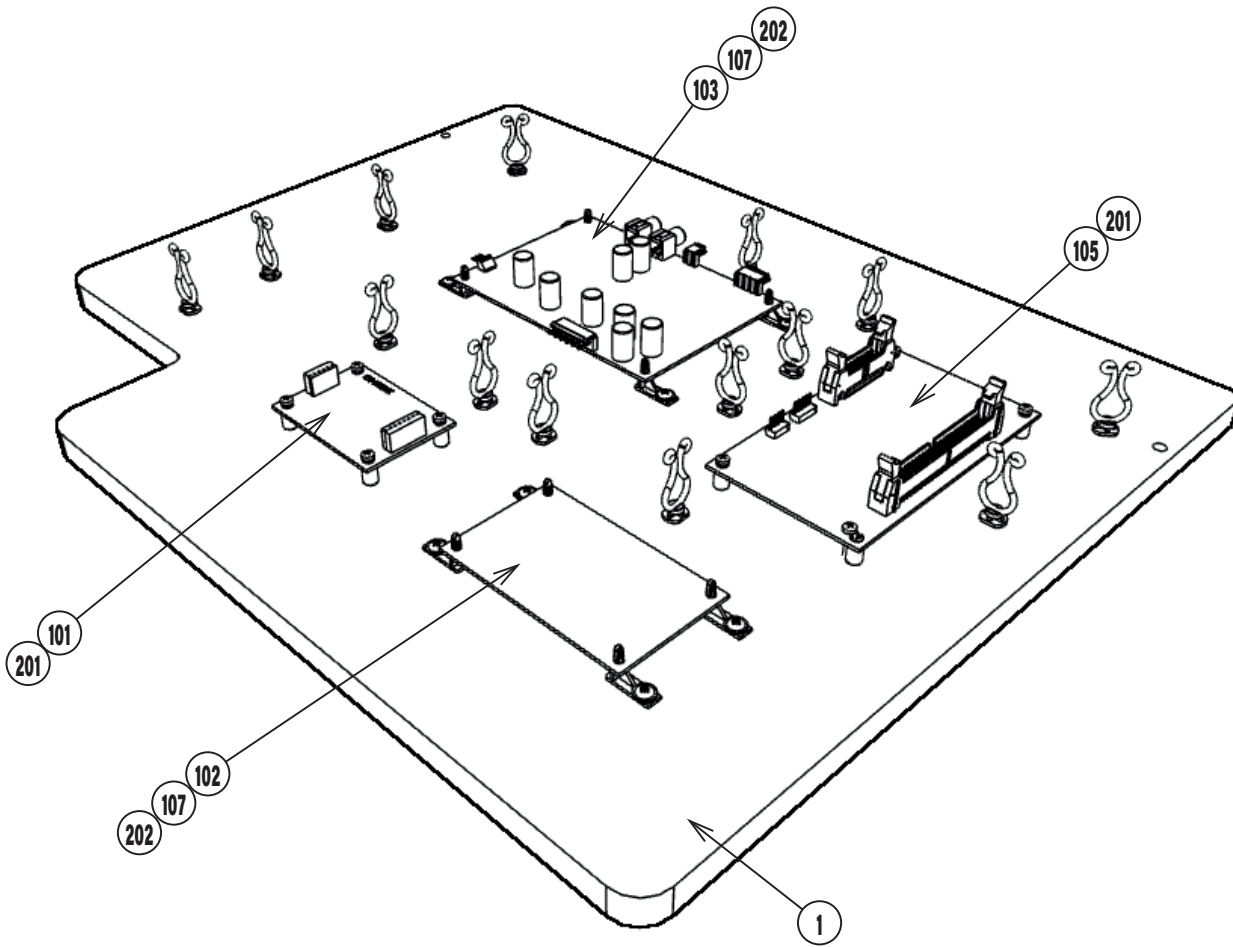

ITEM NO	PART NO	DESCRIPTION	QTY
***1	TS-4001UK	WOODEN BASE MAIN	1
***21	440-CS0010UK	LABEL CAUTION	1
***101	838-0012UK	LAMP DRIVER BOARD	1
***102	837-14981-01	IC BD EXP 8 OUTPUT RS232	1
***103	838-0026UK	AMP 2.1 40W KEENE	1
***105	838-0005UK	I/O BOARD SAE REV3	1
***107	OS1011	PCB FEET RICHCO LCBS-L-5-01	8
***108	280-A01264-WX	ROUTER TWIST D12 SO6.4 WOOD X	14
***201	012-P00325	N4X1" S/TAP PAN PAS	8
***202	012-P03512-F	N6X1/2" S/TAP FLG PAS	8
***301	TS-60006UK	WH I/O	1
***302	TS-60007UK	WH LED DRIVER	1
***306	600-7919-200UK	CA ST JACK TO PHONO	1
***307	600-7142-200UK	USB JVS TYPE A-B FEUSB2HAB2M	1

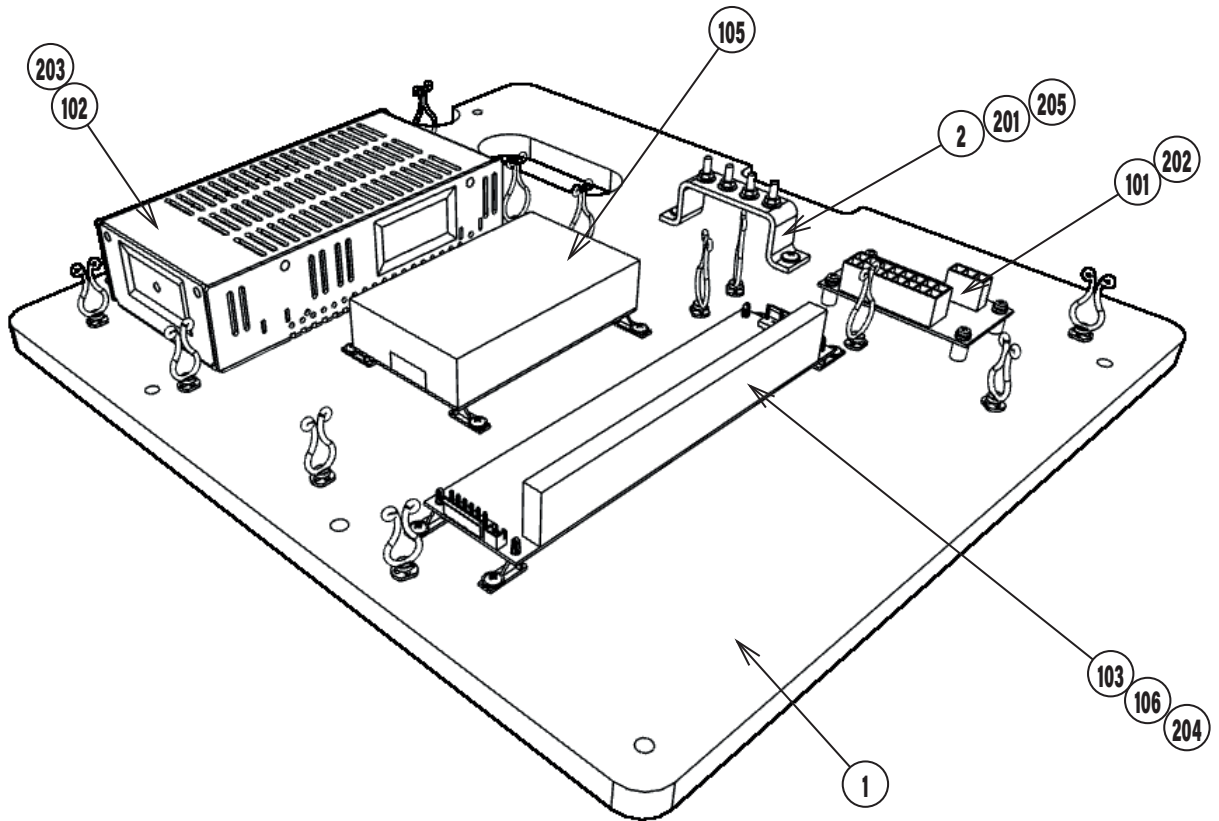

ITEM NO	PART NO	DESCRIPTION	QTY
***1	TS-4101UK	WOODEN BASE PSU	1
***2	CFB-4003-01UK	EARTH TERMINAL PLATE	1
***21	440-DS0010UK	LABEL DANGER HI VOLT	1
***101	838-14551-02UK	AC DISTRIBUTION BOARD	1
***102	400-150-12	PSU 12V DC 150W MW SP-150-12	1
***103	400-075-012-01	PSU 12VDC 75W MW LPS-75-12	1
***105	400-065-0512-01	PSU 5/12V DC 65W MW RPD-65C	1
***106	OS1011	PCB FEET RICRHO LCBS-L-5-01	8
***107	280-A02064-WX	ROUTER TWIST D20 SO6.4 WOOD X	6
***108	280-A01264-WX	ROUTER TWIST D12 SO6.4 WOOD X	7
***201	012-P00412-FB	N8x1/2" S/TAP FLG BLK	2
***202	012-P00325	N4X1" S/TAP PAN PAS	4
***203	000-F00420	M4X20 MSCR CSK PAS	2
***204	012-P03512-F	N6X1/2" S/TAP FLG PAS	8
***205	050-F00400	M4 NUT FLG SER PAS	4
***301	TS-60002UK	WH AC DIST	1
***302	TS-60005UK	WH DC DIST A	1

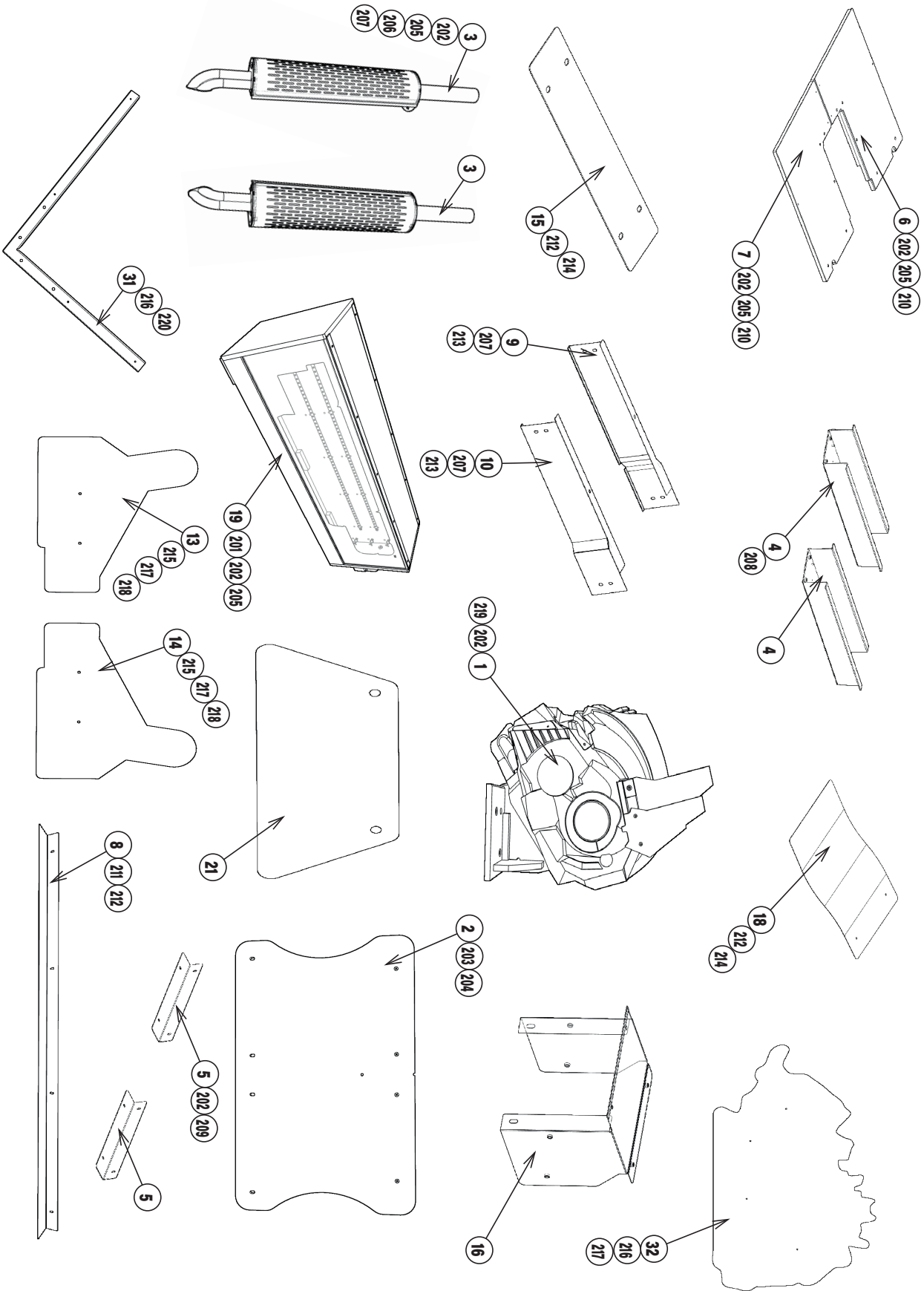

ITEM NO	PART NO	DESCRIPTION	QTY
**1	TS-0500UK	ASSY BILLBOARD TH	1
**2	TS-0004UK	PANEL ROOF	1
**3	TS-0700UK	ASSY EXHAUST PIPE	2
**4	TS-0051UK	JOINT BRIDGE	2
**5	TS-0052UK	BRKT JOINT FLOOR TOP	2
**6	TS-0053UK	JOINT FLOOR L	1
**7	TS-0054UK	JOINT FLOOR R	1
**8	TS-0056UK	JOINT SASH REAR	1
**9	TS-0057UK	JOINT SASH SIDE L	1
**10	TS-0058UK	JOINT SASH SIDE R	1
**13	TS-0013UK	OP SHOULDER L	1
**14	TS-0014UK	OP SHOULDER R	1
**15	TS-0055UK	JOINT SASH MID	1
**16	TS-0059-01UK	JOINT GUN CABI REDUCED	1
**17	TS-0061UK	PLATE JOINT BRIDGE SECURE	4
**18	TS-0062UK	FLAP RODENT SHUT OFF	1
**19	TS-0900UK	ASSY LOGO LIGHT BOX	1
**20	440-CS0186UK	STICKER C EPILEPSY MULTI	1
**21	TS-1914UK	PLAY INSTR SH MULTI	1
***2	TS-1914-01UK	PLAY INSTR SH ENG	1
***3	TS-1914-02UK	PLAY INSTR SH FRE	1
***4	TS-1914-03UK	PLAY INSTR SH TUR	1
***5	TS-1914-04UK	PLAY INSTR SH ITA	1
***6	TS-1914-05UK	PLAY INSTR SH SPA	1
***7	TS-1914-06UK	PLAY INSTR SH RUS	1
**31	TS-0063-01UK	SUPPORT POP PANEL METAL	1
**32	TS-0064UK	PANEL POP	1
**101	LM1227	UK MAINS LEAD 10A WITH PLUG	1
**102	LM1246	EUROLEAD 10A EUROPEAN SOCKET	1
**103	LM1500UK	MAINS LEAD USA/IEC	1
**201	029-B00840-0B	M8X40 SKT BH BLK	10
**202	068-852216-0B	M8 WSHR 22OD FLT BLK	24
**203	029-B00640-0B	M6X40 SKT BH BLK	8
**204	068-652016-0B	M6 WSHR 20OD FLT BLK	8
**205	029-B00850-0B	M8X50 SKT BH BLK	10
**206	029-B00825	M8X25 SKT BH PAS	4
**207	068-852216	M8 WSHR 22OD FLT PAS	12
**208	050-F00800	M8 NUT FLG SER PAS	8
**209	029-B00825-0B	M8X25 SKT BH BLK	4
**210	020-F00860	M8X60 SKT CSK PAS	6
**211	029-B00440	M4X40 SKT BH PAS	4

Please note: TS-0061UK is fitted to the product before shipping.

**212	068-441616	M4 WSHR 16OD FLT PAS	10
**213	029-B00850	M8X50 SKT BH PAS	8
**214	029-B00425	M4X25 SKT BH BLK	6
**215	029-B00612	M6X12 SKT BH PAS	12
**216	068-652016	M6 WSHR 20OD FLT PAS	4
**217	029-B00616	M6X16 SKT BH PAS	4
**218	050-F00600	M6 NUT FLG SER PAS	4
**301	TS-60014UK	WH FLOOR TO REAR	1
**402	420-0030-00UK	MANUAL XFMRS SHADOWS RISING TH	1
**403	OS1019	SELF SEAL BAG 9X12.3/4	1
**406	SAECE-xxx	DECLARATION OF CONFORMITY	1
**421	029-B00840	M8X40 SKT BH PAS	2
**422	068-852216	M8 WSHR 22OD FLT PAS	8
**423	029-B00825	M8X25 SKT BH PAS	6

Please note: Some fixings listed in the ASSY INST KIT are fitted to the product before shipping.

20 WIRE COLOR CODE TABLE

⚠ WARNING

The DC power wire color for this product is different from previous SEGA titles. Working from the previous wire colors will create a high risk of fire.

The color codes for the wires used in the diagrams in the following chapter are as follows.

A	PINK
B	SKY BLUE
C	BROWN
D	PURPLE
E	LIGHT GREEN

Wires other than those of any of the above 5 single colors will be displayed by 2 alphanumeric characters.

1	RED
2	BLUE
3	YELLOW
4	GREEN
5	WHITE
7	ORANGE
8	BLACK
9	GRAY

If the right-hand side numeral of the code is 0, then the wire will be of a single color shown by the left-hand side numeral (see the above).

Note 1: If the right-hand side numeral is not 0, that particular wire has a spiral color code. The left-hand side character shows the base color and the right-hand side one, the spiral color.

<Example> 51.....WHITE/RED

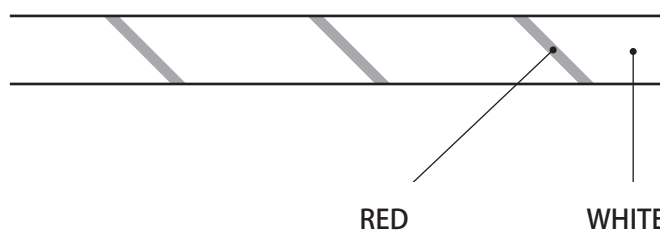

Note 2: The character following the wire color code indicates the size of the wire.

U :	AWG16
K :	AWG18
L :	AWG20
None :	AWG22

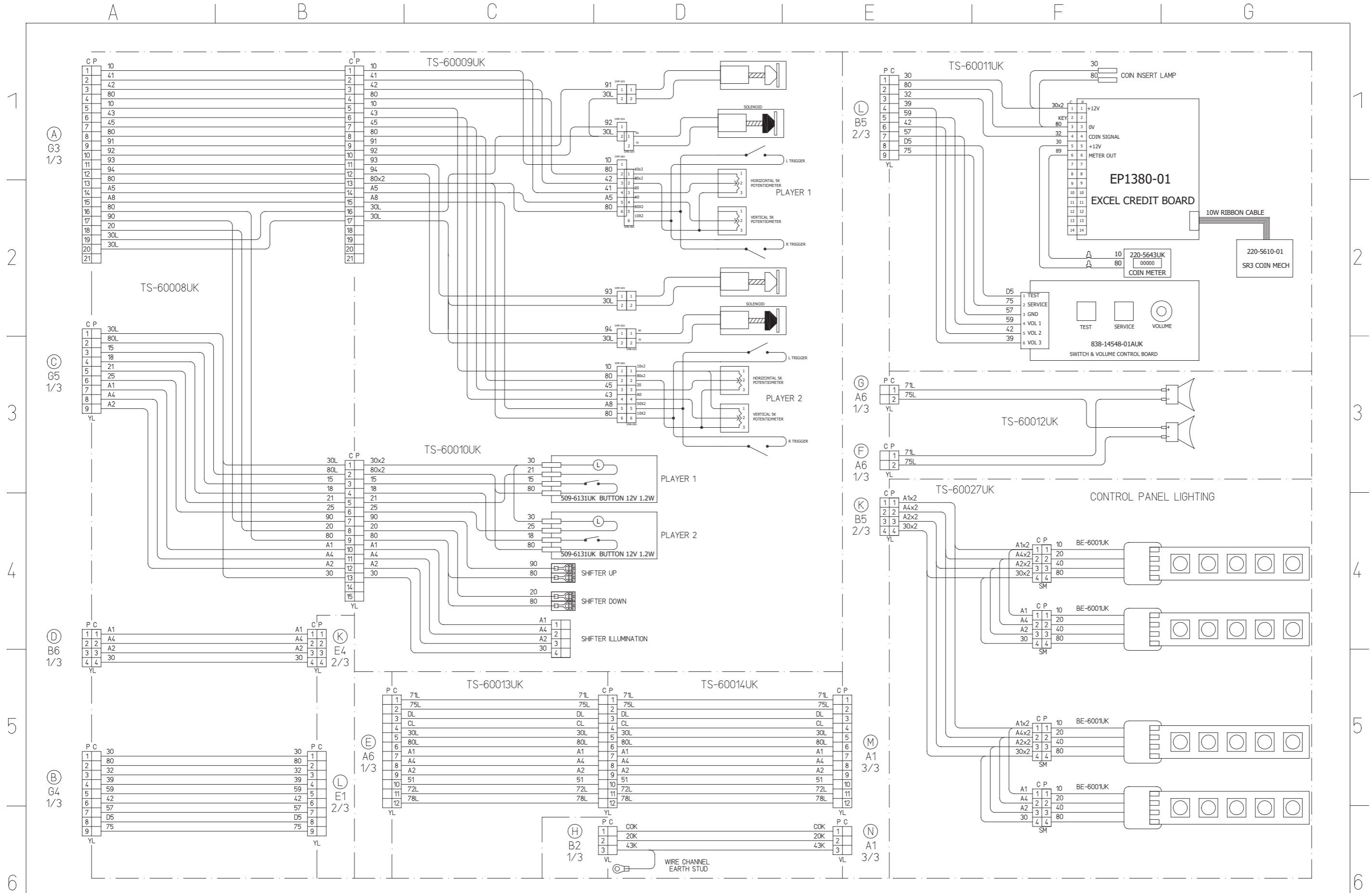

8	BLACK	E	LIGHT GREEN	43	EARTH WIRE
7	ORANGE	D	PURPLE	?	AWG18 UL1672
5	WHITE	C	BROWN	?	AWG20 UL1672
4	GREEN	B	SKY BLUE	U	AWG16 UL1015
3	YELLOW	A	PINK	K	AWG18 UL1015
2	BLUE	9	GRAY	L	AWG20 UL1007
1	RED			T	AWG22 UL1007
					AWG24 UL1007

PAGE 2 OF 4
PART NUMBER

DRAWN

SEGA AMUSEMENTS EUROPE LTD
TRANSFORMERS SHADOWS RISING

THIS DRAWING WILL IN NO WAY BE COPIED, TO BE RETURNED ON DEMAND.

ORIGINAL SIZE
A2

ALTERATION

DESCRIPTION

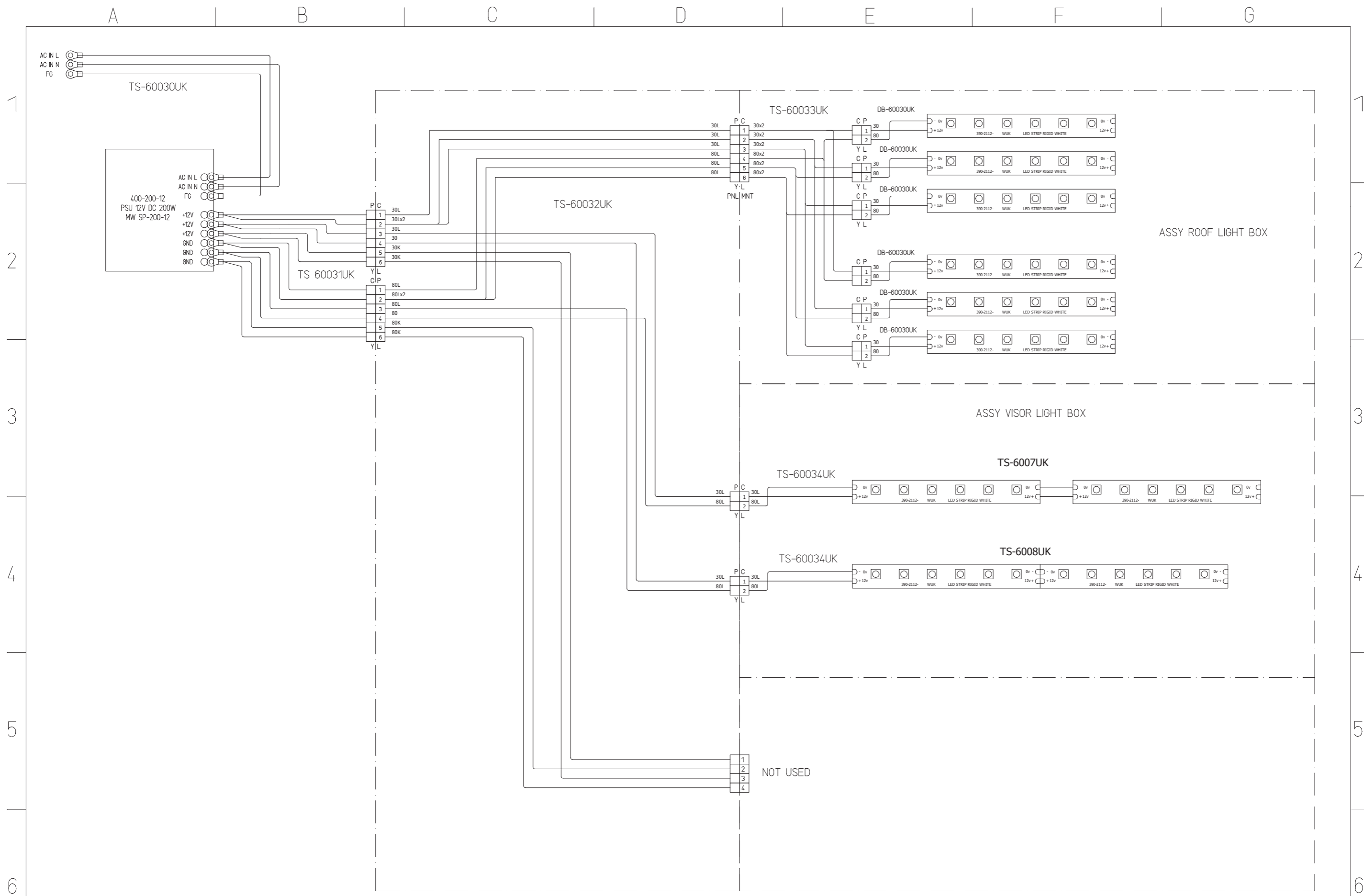

8	BLACK	E	LIGHT GREEN	43	EARTH WIRE
7	ORANGE	D	PURPLE	?	AWG18 UL1672
5	WHITE	C	BROWN	?	AWG20 UL1672
4	GREEN	B	SKY BLUE	U	AWG16 UL1015
3	YELLOW	A	PINK	K	AWG18 UL1015
2	BLUE	9	GRAY	L	AWG20 UL1007
1	RED			T	AWG22 UL1007

PAGE 4 OF 4		DRAWN			
PART NUMBER		DESCRIPTION			

SEGA AMUSEMENTS EUROPE LTD
 TRANSFORMERS SHADOWS RISING
 ORIGINAL SIZE A2
 THIS DRAWING WILL IN NO WAY BE COPIED, TO BE RETURNED ON DEMAND.

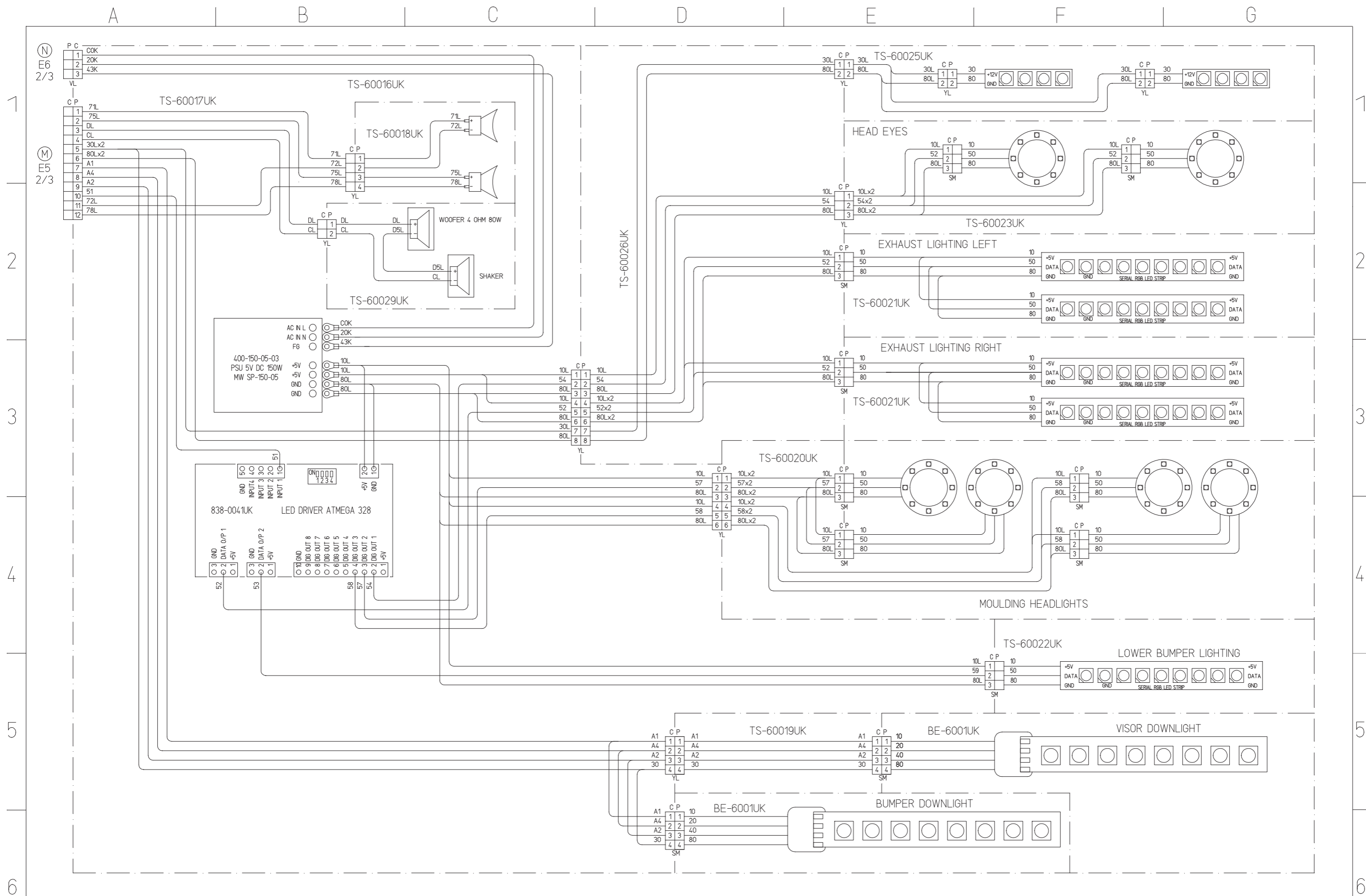

8	BLACK	E	LIGHT GREEN	43	EARTH WIRE
7	ORANGE	D	PURPLE	?	AWG18 UL1672
5	WHITE	C	BROWN	?	AWG20 UL1672
4	GREEN	B	SKY BLUE	U	AWG16 UL1015
3	YELLOW	A	PINK	K	AWG18 UL1015
2	BLUE			L	AWG20 UL1007
1	RED	9	GRAY	T	AWG22 UL1007
					AWG24 UL1007

PAGE 3 OF 4
PART NUMBER

DRAWN

SEGA AMUSEMENTS EUROPE LTD
TRANSFORMERS SHADOWS RISING

THIS DRAWING WILL IN NO WAY BE COPIED.
TO BE RETURNED ON DEMAND.
ORIGINAL SIZE
A2

- SEGA TOTAL SOLUTIONS -

42 Barwell Business Park
Leatherhead Road,
Chessington,
Surrey,
KT9 2NY
United Kingdom

Tel: +44 (0) 208 391 8060
Fax: +44 (0) 208 391 8096



Exclusive Suppliers of SEGA Spares

To Heathrow Airport

